

VISION 15 MODEL

Digital Light Processing (DLP™) Projectors

Vision 15

Vision 15ET

Vision 15ET/CineWide™

TWO YEAR LIMITED WARRANTY

For Projectors, Video Processors and Controllers

Congratulations on your purchase of a Vidikron video product and welcome to the Vidikron family! With proper installation, setup and care, you should enjoy many years of unparalleled video performance.

This is a LIMITED WARRANTY as defined in the Magnuson-Moss Warranty Act. Please read it carefully and retain it with your other important documents.

WHAT IS COVERED UNDER THE TERMS OF THIS LIMITED WARRANTY:

SERVICE LABOR: Planar Systems, Inc. ("Planar") will pay for service labor at an Authorized Service Center when needed as a result of manufacturing defect for a period of two (2) years from the effective date of delivery to the end user (excluding the lamp).

PARTS (not including the lamp): Planar will provide new or rebuilt replacement parts for the parts that fail due to defects in materials or workmanship for a period of two (2) years from the effective date of delivery to the end user. Such replacement parts are then subsequently warranted for the remaining portion (if any) of the original warranty period.

PROJECTOR LAMP: Planar will pay for service labor at an Authorized Service Center when needed as a result of a manufacturing defect for a period of six (6) months or 1000 hours, whichever comes first, from the effective date of delivery to the end user. In addition, Planar will provide a new or rebuilt replacement lamp for the lamp that fails due to defects in materials or workmanship for a period of six (6) months or 1000 hours, whichever comes first, from the effective date of delivery to the end user. Such replacement lamps are then subsequently warranted for the remaining portion (if any) of the original warranty period.

WHAT IS NOT COVERED UNDER THE TERMS OF THIS LIMITED WARRANTY:

This Limited Warranty only covers failure due to defects in materials and workmanship that occur during normal use and does not cover normal maintenance. This Limited Warranty does not cover cabinets or any appearance items; failure resulting from accident, misuse, abuse, neglect, mishandling, misapplication, faulty or improper installation or setup adjustments; improper maintenance, alteration, improper use of any input signal; damage due to lightning or power line surges, spikes and brownouts; damage that occurs during shipping or transit; or damage that is attributed to acts of God. In the case of remote control units, damage resulting from leaking, old, damaged or improper batteries is also excluded from coverage under this Limited Warranty.

CAUTION: THIS LIMITED WARRANTY ONLY COVERS VIDIKRON PRODUCTS PURCHASED FROM AUTHORIZED VIDIKRON DEALERS. ALL OTHER PRODUCTS ARE SPECIFICALLY EXCLUDED FROM COVERAGE UNDER THIS WARRANTY. MOREOVER, DAMAGE RESULTING DIRECTLY OR INDIRECTLY FROM IMPROPER INSTALLATION OR SETUP IS SPECIFICALLY EXCLUDED FROM COVERAGE UNDER THIS LIMITED WARRANTY. IT IS IMPERATIVE THAT INSTALLATION AND SETUP WORK BE PERFORMED ONLY BY AN AUTHORIZED VIDIKRON DEALER TO PROTECT YOUR RIGHTS UNDER THIS WARRANTY. THIS WILL ALSO ENSURE THAT YOU ENJOY THE FINE PERFORMANCE OF WHICH YOUR VIDIKRON PRODUCT IS CAPABLE WHEN INSTALLED AND CALIBRATED BY AN AUTHORIZED VIDIKRON DEALER.

RIGHTS, LIMITS AND EXCLUSIONS:

Planar limits its obligations under any implied warranties under state laws to a period not to exceed the warranty period. There are no express warranties. Planar also excludes any obligation on its part for incidental or consequential damages related to the failure of this product to function properly. Some states do not allow limitations on how long an implied warranty lasts, and some states do not allow the exclusion or limitation of incidental or consequential damages. So the above limitations or exclusions may not apply to you. This warranty gives you specific legal rights, and you may also have other rights that vary from state to state.

EFFECTIVE WARRANTY DATE:

This warranty begins on the effective date of delivery to the end user. For your convenience, keep the original bill of sale as evidence of the purchase date.

IMPORTANT – WARRANTY REGISTRATION:

Please fill out and mail your warranty registration card. It is imperative that Planar knows how to reach you promptly if we should discover a safety problem or product update for which you must be notified.

CONTACT AN AUTHORIZED SERVICE CENTER TO OBTAIN SERVICE:

Repairs made under the terms of this Limited Warranty covering your Vidikron video product will be performed at the location of the product, during usual working hours, providing location of product is within normal operating distance from an Authorized Vidikron Service Center. In some instances it may be necessary for the product to be returned to the Vidikron factory for repairs. If, solely in Planar's judgment, location of product to be repaired is beyond normal operating distance of the closest Authorized Vidikron Service Center, or the repair requires the unit be returned to the Vidikron factory, it is the owner's responsibility to arrange for shipment of the product for repair. These arrangements must be made through the selling Vidikron Dealer. If this is not possible, contact Planar directly for a Return Authorization number and shipping instructions. Planar will return product transportation prepaid in the United States, unless no product defect is discovered. In that instance, shipping costs will be the responsibility of the owner.

COPYRIGHT AND TRADEMARKS:

© Copyright 2008 Planar Systems, Inc. This document contains proprietary information protected by copyright, trademark and other intellectual property laws. All rights are reserved. No part of this manual may be reproduced by any mechanical, electronic or other means, in any form, without prior written permission of the manufacturer.

Trademarks and registered trademarks used in this document are the property of their respective owners.

Vidikron products are manufactured under one or more of the following patents: US. Patent 6755540 and Other Patents Pending.

ADDITIONAL INFORMATION:

To locate the name and address of the nearest Authorized Vidikron Service Center, or for additional information about this Limited Warranty, please call or write:

PLANAR SYSTEMS, INC.
1195 NW Compton Drive
Beaverton, OR 97006-1992
Ph: (503) 748-5799
Fax: (503) 682-9441
Toll Free: (866) PLANAR1

PRODUCT INFORMATION
RETAIN FOR YOUR RECORDS

Model Purchased

Date

Serial Number

Vidikron Authorized Dealer Name

Address

City

State/Province

Postal Code

Phone

Fax

Important Safety Instructions

Thank you for your purchase of this quality Vidikron video projector! It has been designed to provide you with the quality of video that is expected in a home theater. For the best performance, please read this manual carefully as it is your guide through the menus and operation.

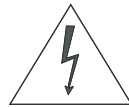
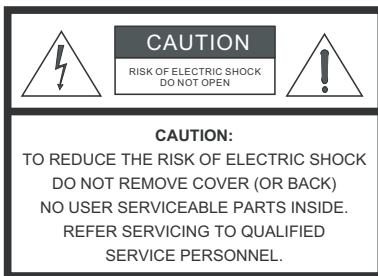

WARNING

This symbol is intended to alert the user to the presence of uninsulated "dangerous voltage" within the product's enclosure that may be of sufficient magnitude to constitute a risk of electric shock.



This symbol is intended to alert the user to the presence of important operating and maintenance (servicing) instructions in the literature accompanying the appliance.

1. Read these instructions.
2. Keep these instructions.
3. Heed all warnings.
4. Follow all instructions.
5. Do not use this apparatus near water.
6. Clean only with a dry cloth.
7. Do not block any of the ventilation openings. Install in accordance with the manufacturer's instructions.
8. Do not install near any heat sources such as radiators, heat registers, stoves, or other apparatus (including amplifiers) that produce heat.
9. Do not defeat the safety purpose of the polarized or grounding type plug. A polarized plug has two blades with one wider than the other. A grounding type plug has two blades and a third grounding prong. The wide blade or the third prong is provided for your safety. When the provided plug does not fit into your outlet, consult an electrician for the replacement of the obsolete outlet.
10. Protect the power cord from being walked on or pinched particularly at plugs, convenience receptacles and the point where they exit from the apparatus.
11. Only use the attachments/accessories specified by the manufacturer.
12. Use only with a cart, stand, tripod, bracket or table specified by the manufacturer or sold with the apparatus. When a cart is used, use caution when moving the cart/apparatus to avoid injury from tip-over.
13. Unplug this apparatus during lightning storms or when unused for long periods of time.
14. Refer all servicing to qualified service personnel. Servicing is required when the apparatus has been damaged in any way, such as power supply cord or plug is damaged, liquid has been spilled or objects have fallen into the apparatus, the apparatus has been exposed to rain or moisture, does not operate normally, or has been dropped.
15. The +12V trigger only outputs 12Vdc signal for triggering. Do not connect to any other power input or output. This could cause damage to this unit.
16. Keep the packing material in case the equipment should ever need to be shipped.
17. The lamp becomes extremely hot during operation. Allow the projector to cool down for approximately 45 minutes prior to removing the lamp assembly for replacement.



18. Do not operate lamps beyond the rated lamp life. Excessive operation of lamps beyond rated life could cause them to explode in rare occasions.
19. Never look directly into the lens when the lamp is on.

Compliance Information

DECLARATION OF CONFORMITY:

Manufacturer's Name: Planar Systems, Inc.

Manufacturer's Address: 1195 NW Compton Drive, Beaverton, OR 97006-1992

hereby declares that the products Model Numbers:

Vision 15, Vision 15ET and Vision 15ET/CineWide

conform with the provisions of:

Council Directive 2004/108/EC on Electromagnetic Compatibility;

EN 55022 "Limits and methods of measurements of radio interference characteristics of information technology equipment" 1998;

EN 55024 "Limits and methods of measurements of immunity characteristics of information technology equipment" 1998;

Including:

- EN 61000-4-2 "Electromagnetic compatibility (EMC) Part 4: Testing and measurement techniques Section 2: Electrostatic discharge immunity test"
- EN 61000-4-3 "Electromagnetic compatibility (EMC) Part 4: Testing and measurement techniques Section 3: Radiated, Radio-Frequency, Electromagnetic Field Immunity Test"
- EN 61000-4-4 "Electromagnetic compatibility (EMC) Part 4: Testing and measurement techniques Section 4: Electrical fast transient/burst immunity test"
- EN 61000-4-5 "Electromagnetic compatibility (EMC) Part 4: Testing and measurement techniques Section 5: Surge immunity test"
- EN 61000-4-6 "Electromagnetic compatibility (EMC) Part 4: Testing and measurement techniques Section 6: Conducted disturbances induced by radio-frequency fields immunity test"
- EN 61000-4-8 "Electromagnetic compatibility (EMC) Part 4: Testing and measurement techniques Section 8: Conducted disturbances induced by power frequency magnetic fields immunity test"
- EN 61000-4-11 "Electromagnetic compatibility (EMC) Part 4: Testing and measurement techniques Section 11: Voltage dips, short interruptions and voltage variations immunity tests"

And:

- EN 61000-3-2 "Electromagnetic compatibility (EMC) Part 3, Section 2: Limits for harmonic current emissions (equipment input current up to and including 16 A per phase)" 2000;
- EN 61000-3-3 "Electromagnetic compatibility (EMC) Part 3, Section 3: Limitations of voltage changes, voltage fluctuations and flicker in public low-voltage supply systems, for equipment with rated current up to and including 16 A and not subject to conditional connection" 1995;

Council Directive 2006/95/EC and amended by M1 and C1 on Low Voltage Equipment Safety;

EN 60950 "Safety of information technology equipment, including electrical business equipment"

The Technical Construction file required by this Directive is maintained at the corporate headquarters of Planar Systems, Inc., 1195 NW Compton Drive, Beaverton, OR 97006-1992.

Date of Declaration: January 2008

FCC PART 15:

NOTE: This equipment has been tested and found to comply with the limits for a Class B digital device, pursuant to Part 15 of the FCC Rules. These limits are designed to provide reasonable protection against harmful interference in a residential installation.

This equipment generates, uses and can radiate radio frequency energy and, if not installed and used in accordance with the instructions, may cause harmful interference to radio communications. However, there is no guarantee that interference will not occur in a particular installation. If this equipment does cause harmful interference to radio or television reception, which can be determined by turning the equipment off and on, the user is encouraged to try to correct the interference by one or more of the following measures:

- Reorient or relocate the receiving antenna.
- Increase the separation between the equipment and receiver.
- Connect the equipment into an outlet on a circuit different from that to which the receiver is connected.
- Consult the dealer or an experienced radio/TV technician for help.

INDUSTRY CANADA (ICES-003):

This Class B digital apparatus complies with Canadian ICES-003.

Cet appareil numérique de la classe B est conforme à la norme NMB-003 du Canada.

IMPORTANT RECYCLE INSTRUCTIONS



Lamp(s) inside this product contain mercury. This product may contain other electronic waste that can be hazardous if not disposed of properly. Recycle or dispose in accordance with local, state, or federal Laws.

For more information, contact the Electronic Industries Alliance at WWW.EIAE.ORG.

For lamp specific disposal information check WWW.LAMPRECYCLE.ORG.

DISPOSAL OF OLD ELECTRICAL AND ELECTRONIC EQUIPMENT (Applicable throughout the European Union and other European countries with separate collection programs)

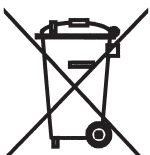

This symbol found on your product or on its packaging, indicates that this product should not be treated as household waste when you wish to dispose of it. Instead, it should be handed over to an applicable collection point for the recycling of electrical and electronic equipment. By ensuring this product is disposed of correctly, you will help prevent potential negative consequences to the environment and human health, which could otherwise be caused by inappropriate disposal of this product. The recycling of materials will help to conserve natural resources. This symbol is only valid in the European Union. If you wish to discard this product, please contact your local authorities or dealer and ask for the correct method of disposal.

Table of Contents

TWO YEAR LIMITED WARRANTY	iii
Important Safety Instructions	vi
Compliance Information	vii
1. Introduction	1
About This Manual	1
If You Have Comments About This Manual...	1
Textual and Graphic Conventions	1
Using This Manual	2
Description, Features and Benefits	3
Key Features and Benefits.....	4
Parts List	4
2. Controls and Functions	5
Vision 15 at a Glance	5
Vision 15 Rear Panel	6
Vision 15 Remote Control	8
3. Installation	11
Remote Control	11
Notes on Batteries	11
Notes on Remote Control Operation.....	12
Quick Setup	13
Installation Considerations	14
Installation Type.....	14
Ambient Light	14
Throw Distance.....	15
Vertical and Horizontal Position.....	16
Vertical and Horizontal Lens Shift.....	17
Folded Optics	19
Other Considerations	20
Installing the Optional CineWide Lens Base Plate	20
Mounting the Vision 15	22
Floor Mounting (Upright)	22
Ceiling Mounting (Inverted)	22
Adjusting the Projector Height or Projection Angle.....	22

Connections to the Vision 15	23
Connector Panel Access	23
Connecting Source Components to the Vision 15	23
RS-232 Controller Connection	28
Connecting 12-Volt Trigger Output to External Theater Equipment	29
Turning on the Power	29
Changing the OSD Language	30
Adjusting the Picture Orientation	30
Primary Lens Adjustments	31
Focus and Zoom.....	31
Shift	32
Installing and Adjusting the CineWide Anamorphic Lens	33
4. Operation	35
Using the On-Screen Menus	35
Main Menu	36
Source Select	37
Picture Adjust.....	37
Aspect Ratio.....	42
Installation.....	45
Information	48
Setup	49
ISF	50
5. Maintenance and Troubleshooting	53
Cleaning the Projector	53
Cleaning the Lens	53
Cleaning the Intake and Exhaust Vents	54
Lamp Maintenance	55
Lamp Cautions	55
Lamp Replacement	56
Troubleshooting Tips	57
6. Serial Communications	59
RS-232 Connection and Port Configuration	59
Serial Command Syntax	59

7. Specifications	61
Vision 15 Specifications	61
Vision 15 Dimensions	63
Vision 15ET Dimensions	64
Computer Signal Compatibility	65
Video Signal Compatibility	66

Notes:

List of Figures

2-1. Vision 15 Front/Side/Top View	5
2-2. Vision 15 Rear Panel	6
2-3. Vision 15 Remote Control	8
3-1. Available Range of the Remote Control	12
3-2. Estimating Throw Distance	15
3-3. Projector Placement	16
3-4. Vertical Lens Shift (Example only)	17
3-5. Horizontal Lens Shift (Example only)	18
3-6. Folded Optics	19
3-7. Vision 15ET/CineWide with Lens Base Plate and Ceiling Mounting Plate - Exploded View .	21
3-8. Adjusting the Feet	22
3-9. HDMI/DVI Source Connections	24
3-10. RGB Connections	25
3-11. Component Video Connections	26
3-12. Composite and S-Video Connections	27
3-13. RS-232 Control System Connection	28
3-14. Connecting the 12-Volt Trigger Output to Other Equipment	29
3-15. Focus and Zoom Controls	31
3-16. Vertical and Horizontal Lens Shift Controls	32
3-17. Anamorphic Lens Mounting Assembly - Exploded View	33
4-1. Vision 15 OSD Menu Structure	36
4-2. Typical PLUGE Pattern for Adjusting Brightness	38
4-3. Typical Gray Bar Pattern for Adjusting Contrast	38
4-4. Typical Color Bar Pattern for Adjusting Color Saturation and Tint	39
4-5. Typical Test Pattern for Adjusting Sharpness	40
4-6. Keystone Correction	46
4-7. Overscan Examples	47
7-1. Vision 15 Dimensions	63
7-2. Vision 15ET Dimensions	64

Notes:

Introduction

This manual describes how to install, set up and operate a Vidikron Vision 15 Series Digital Light Processing (DLP™) Projector. This product family consists of three models:

- Vision 15
- Vision 15ET (Extended-Throw)
- Vision 15ET/CineWide

Throughout this manual, all three projectors are referred to collectively as the "Vision 15." The information in this manual applies to all three projectors except where otherwise indicated.

Vidikron has prepared this manual to help home theater installers and end users get the most out of the Vision 15.

Vidikron has made every effort to ensure that this manual is accurate as of the date it was printed. However, because of ongoing product improvements and customer feedback, it may require updating from time to time. You can always find the latest version of this and other Vidikron product manuals on-line, at www.Vidikron.com.

Vidikron welcomes your comments about this manual. Send them to info@Vidikron.com.

Text Conventions: The following conventions are used in this manual, in order to clarify the information and instructions provided:

- Remote and built-in keypad button identifiers are set in upper-case bold type; for example, "Press **EXIT** to return to the previous menu."
- Computer input (commands you type) and output (responses that appear on-screen) is shown in monospace (fixed-width) type; for example: "To change the aspect ratio to Letterbox, type `RRD02`."
- All keys with functional names are initial-capped, set in bold type and enclosed in angle brackets. These keys are the following: **<Enter>**, **<Spacebar>**, **<Control>**, **<Esc>** and **<Tab>**.
- **<Enter>** indicates that you may press either the RETURN or ENTER key on your keyboard if it has both keys.

In addition to these conventions, underlining, boldface and/or italics are occasionally used to highlight important information, as in this example:



Note

*A carriage return **must** be used after each command or string.*

1.1 About This Manual

◀ ***If You Have Comments About This Manual...***

◀ ***Textual and Graphic Conventions***

Graphic Conventions: These symbols appear in numerous places throughout the manual, to emphasize points that you must keep in mind to avoid problems with your equipment or injury:



Tip

TIPS highlight time-saving short cuts and helpful guidelines for using certain features.



Note

NOTES emphasize text with unusual importance or special significance. They also provide supplemental information.



Caution

CAUTIONS alert users that a given action or omitted action can degrade performance or cause a malfunction.



WARNING

WARNINGS appear when a given action or omitted action can result in damage to the equipment, or possible non-fatal injury to the user.



DANGER!

DANGER appears when a given action can cause severe injury or death.

1.2 Using This Manual

Use the following table to locate the specific information you need in this manual.

If you need...	... Turn to page:
Information about obtaining service	iv
General information about the Vision Model 15 Series DLP Projectors	3
Installation instructions	11
First-time configuration instructions	30
Advanced configuration instructions	49
Troubleshooting tips	57
Specifications for the Vision Model 15 Series DLP Projectors	61

The Vidikron Vision Model 15 Series DLP Projectors combines a highly efficient optical light engine with broad installation and integration options.

Vidikron has implemented a host of advancements into the projector's light engine to take full advantage of its widescreen, high-definition Digital Micromirror Device (DMD™) chip. The Vision 15 features Enhanced GEN 3™ technology to produce deeper blacks, greater contrast ratio and brightness, and richly saturated colors.

Among the Vision 15's features are a sophisticated color-balancing system that results in the industry's best gray scale tracking, and far surpasses the capabilities of CRT projectors. Accurate gray scale reproduction is vital to vibrant, true-to-life color reproduction, as well as superior black level and white level performance. Vidikron's acclaimed Imagix™ video processing and scaling assure pristine video imagery, while the Vision 15's generous light output capability is powerful enough to handle screens as large as 96 inches wide with ease.

The Vision 15 features a 16:9 aspect ratio resolution of 1280 x 720. It provides an HDMI input for pure digital video signal transmission. In addition, the projector's broad lens shift capability, variable throw distance, and electronic horizontal and vertical keystone correction allow for flexible placement within virtually any theater environment. Discrete IR and/or serial control makes it simple to partner the Vision 15 with other audio/video components and automated control systems for a truly high-end, home cinema system.

For uncompromising widescreen reproduction of movies originally filmed in the "scope" (2.35:1) format, the Vision 15 can be equipped with Vidikron's patent-pending CineWide™ technology, a combination of software, electronics and high-quality anamorphic optics. CineWide maintains constant vertical height on the screen just as in a movie theater. When a viewer transitions from 1.78:1 (16:9) program material to 2.35:1, the image simply gets wider while full height is maintained.

**Note**

CineWide requires the use of a 2.35:1 or similar aspect ratio superwide format screen.

1.3 Description, Features and Benefits

- Key Features and Benefits** ➤ The Vision 15 offers these key features and benefits:
- Native Resolution: 1280 x 720
 - High-performance Digital Light Processing (DLP™) engine
 - HDMI Input with High-bandwidth Digital Content Protection (HDCP)
 - HDTV Compatible
 - Brilliant Color™ provides enhanced primary and secondary color processing for more lifelike images

- Parts List** ➤ Your Vision 15 is shipped with the following items. If any items are missing or damaged, please contact your Vidikron dealer or Vidikron Customer Service at (888) 4VIDIKRON.
- Vision 15 DLP Projector
 - Remote Control Unit and two (2), AAA-size batteries
 - AC Power Cord (by country)
 - HDMI to HDMI Cable
 - Serial Communication Cable (D-sub 9-pin female to Mini-DIN 9-pin male), 5.9 in. (15 cm)
 - Warranty information and registration card
 - Vidikron Vision Model 15 Installation/Operation Manual (this document)

Optional Accessories:

- CineWide™ technology (fixed, secondary anamorphic lens)
- Ceiling mount kit (part number 956-0256-00)

Controls and Functions

Figure 2-1 shows the locations of key Vision 15 components.

2.1 Vision 15 at a Glance

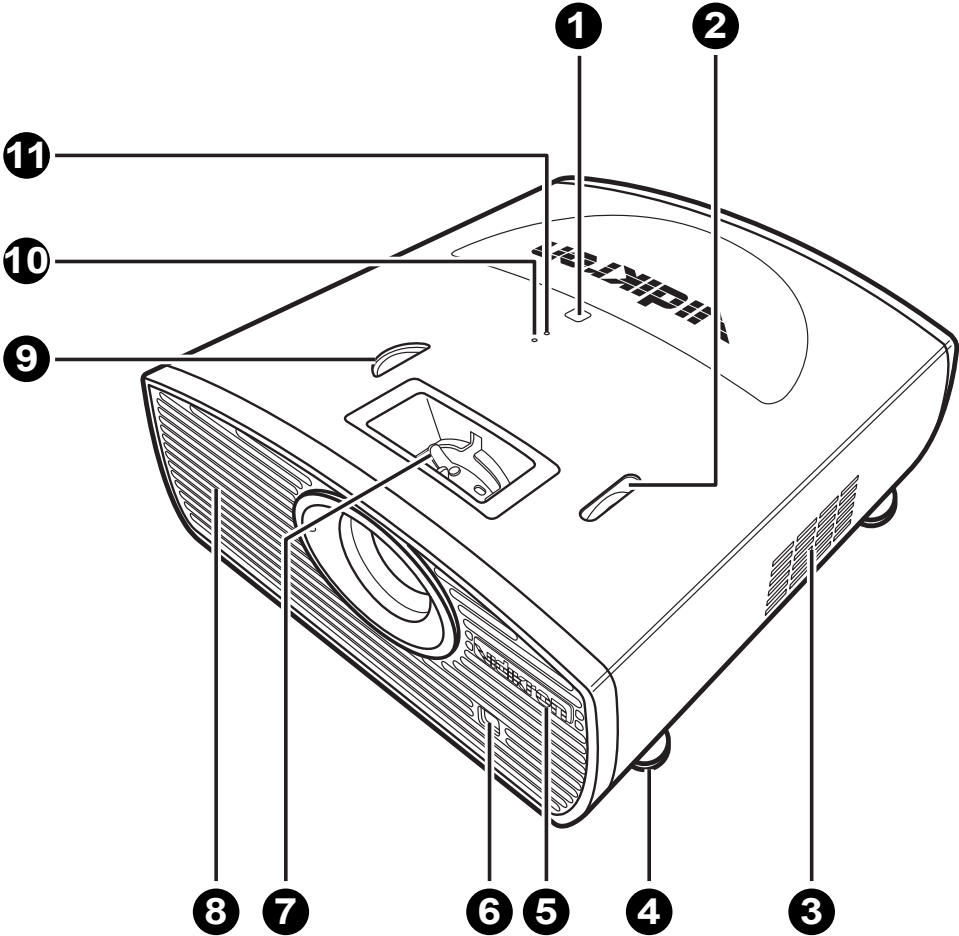

Figure 2-1. Vision 15 Front/Side/Top View

- 1. **TOP IR SENSOR**
- 2. **VERTICAL LENS SHIFT DIAL**
Shifts the image up or down.
- 3. **INTAKE VENT**
- 4. **ADJUSTABLE FEET**
Use to adjust the height or projection angle.
- 5. **VIDIKRON LOGO**
The logo can be rotated to match the projector orientation: inverted (ceiling-mounted) or upright. To rotate the logo, grip it at the sides, pull it away from the projector and rotate it 180 degrees.

6. **FRONT IR SENSOR**
7. **ZOOM/FOCUS RING**
Use this to change the projected image size or focus the image.
8. **EXHAUST VENT**
9. **HORIZONTAL LENS SHIFT DIAL**
Shifts the image left or right.
10. **TEMPERATURE INDICATOR**
Flashes blue when the projector is overheated.
11. **POWER/STANDBY INDICATOR**
Indicates power status as follows:
 - Lights solid blue when the projector is in standby mode
 - Off during normal operation
 - Flashes blue after the projector is turned off to indicate that the lamp is cooling down

2.2 Vision 15 Rear Panel

Figure 2-2 shows the Vision 15 rear panel.

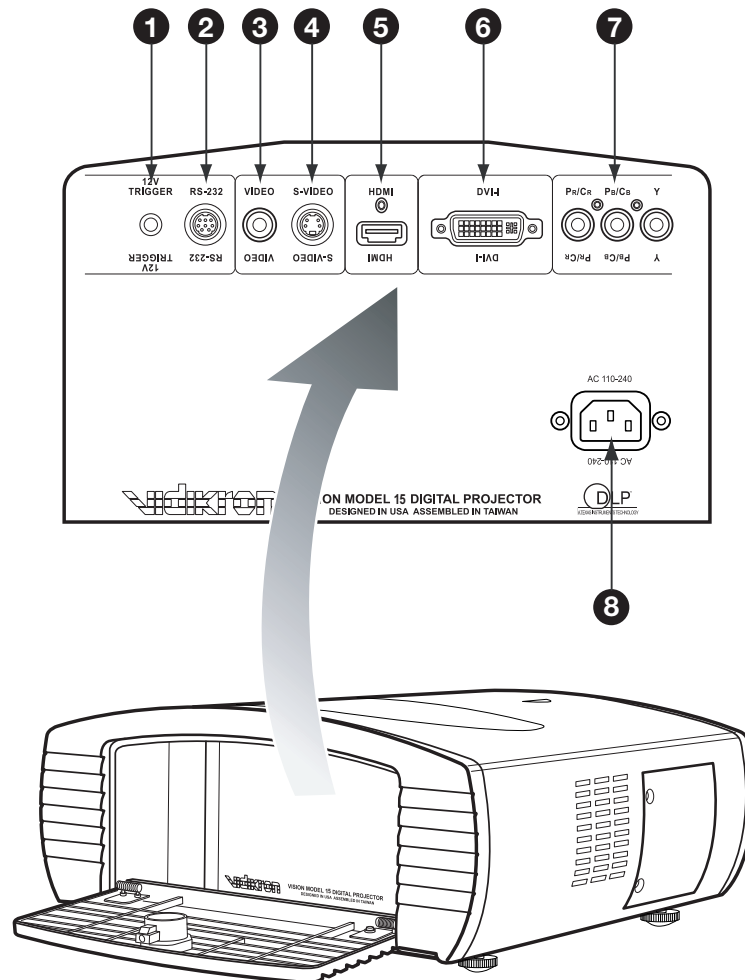

Figure 2-2. Vision 15 Rear Panel

-
1. **12-VOLT (250 mA) TRIGGER OUTPUT (3.5-mm mini phono jack; Tip = +12V; Sleeve = Ground)**
Connection for a retractable screen, screen mask or other, 12-volt trigger-activated device.
 2. **RS-232 CONTROL PORT**
A female, 9-pin mini-DIN connector for interfacing with a PC or home theater automation/control system.
 3. **COMPOSITE VIDEO INPUT**
Standard composite video input for connecting a VCR, laser disc player or other composite video source.
 4. **S-VIDEO**
A standard S-Video input for connecting a DVD player, satellite receiver or Super VHS (S-VHS) VCR.
 5. **HDMI**
HDCP-compliant digital video input for connecting a DVD player or HD tuner with a DVI or HDMI output.
 6. **DVI-I (Analog/Digital)**
Accepts either an HDCP-compliant, digital video input (DVI-D) or an RGB PC signal from a personal computer (DVI-A).
 7. **COMPONENT VIDEO (RCA connectors)**
Standard- or high-definition (480i/480p/576i/576p/720p/1080i/1080p) Component (YPrPb) input for connecting a DVD/HD-DVD/BD player, HD set-top box or other SD/HD source.



For best results, do not run your DVD player in progressive mode.

8. **POWER INPUT (100 to 240 VAC)**
Connect the Vision 15 to power here.

2.3 Vision 15 Remote Control

Figure 2-3 shows the Vision 15 remote control, and the paragraphs that follow describe its functionality.

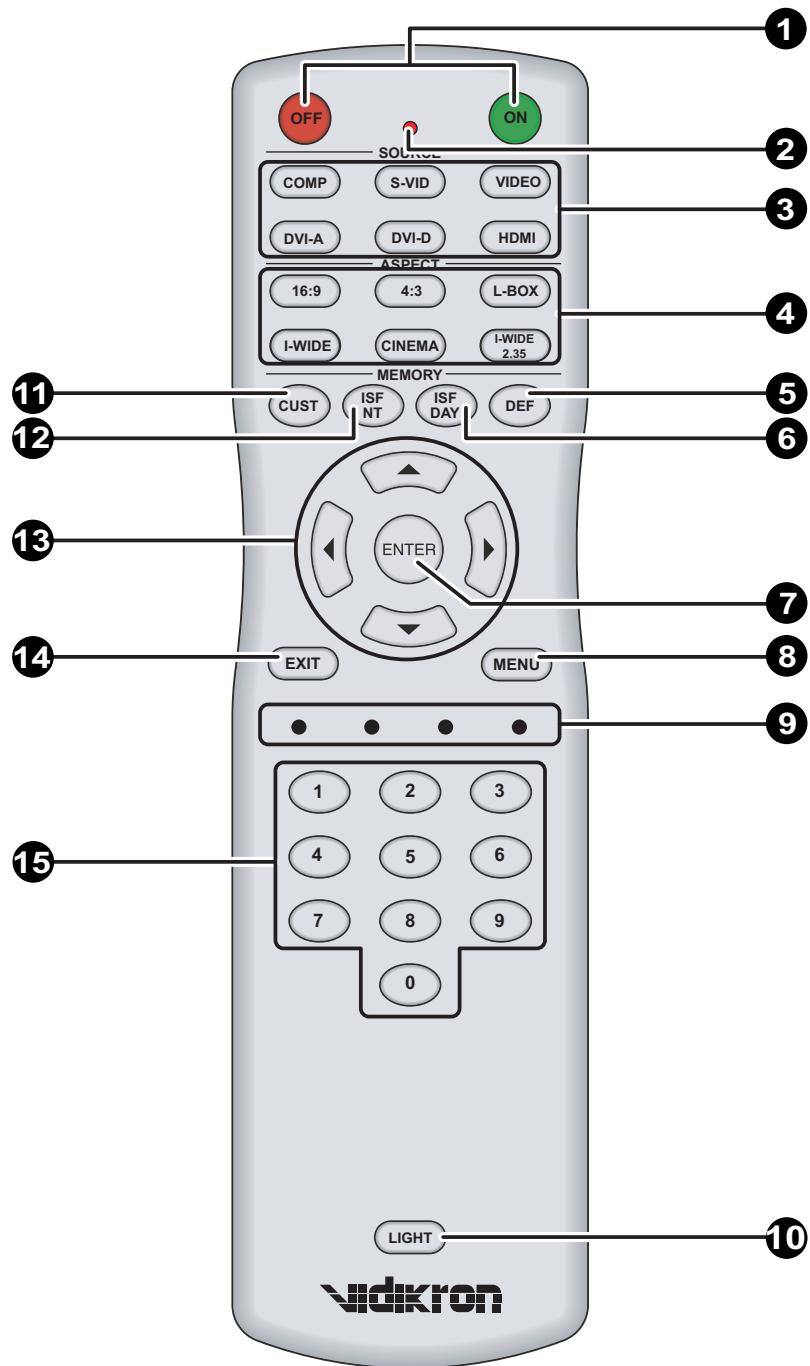

Figure 2-3. Vision 15 Remote Control

1. ON / OFF

Press to turn the projector on or off.

2. IR OUTPUT INDICATOR

Lights when a button is pressed to indicate that an IR signal is being transmitted.

3. Source Selection Buttons:**VIDEO**

Press to switch to the Composite video input.

S-VIDEO

Press to switch to the S-Video input.

COMP

Press to switch to the Component (480i/480p/576i/576p/720p/1080i/1080p) video input.

DVI-A

Press to switch to the DVI-A input.

DVI-D

Press to switch to the DVI-D input.

HDMI

Press to switch to the HDMI input.

4. Aspect Ratio Selection Buttons

Use these buttons to select an aspect ratio directly, as follows:

16:9

For viewing 16:9 DVDs or HDTV programs in their native aspect ratio.

4:3

Scales the input signal to fit 4:3 display mode in the center of the screen.

LETBOX (Letterbox)

For viewing LaserDisc movies or non-anamorphic DVDs on a 16:9 screen.

I-WIDE (IntelliWide)

Enlarges a 4:3 image horizontally in a NON-linear fashion to fit 16:9 full screen display.

CINEMA

For viewing 2.35:1 source material.

I-WIDE (IntelliWide 2.35 – Vision 15ET/CineWide only)

Selects the IntelliWide 2.35 aspect ratio, used for viewing 16:9 source material on a 2.35:1 screen.

5. DEF

Press to restore factory-default settings for the current source.

6. ISF DAY

Press to recall settings for the current input from the "ISF Day" memory preset.

7. ENTER

Press to select a highlighted menu item or confirm a changed setting.

8. **MENU**
Press this button to access the on-screen display (OSD) controls.
9. Not used.
10. **LIGHT**
Press this button to illuminate the buttons.
11. **CUST**
Press to recall settings for the current input from the "Custom" memory preset.
12. **ISF NT**
Press to recall settings for the current input from the "ISF Night" memory preset.
13. **Cursor Keys (▲, ◀, ▼, ▶)**
Use these buttons to select items or settings, adjust settings or switch display patterns.
14. **EXIT**
Press this button to exit the current menu and return to the previous one.
15. **NUMBER KEYS**
Use these buttons to enter menu passcodes.

To install batteries in the remote control:

1. Press down the tab on the cover and pull the cover in the direction of the arrow.

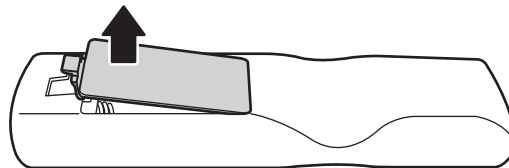

2. Insert the included batteries. Ensure that the polarities correctly match the \oplus and \ominus markings inside the battery compartment.

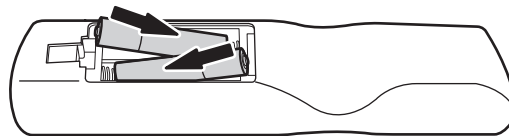

3. Insert the lower tab of the cover into the opening, and press down the cover until it clicks in place.

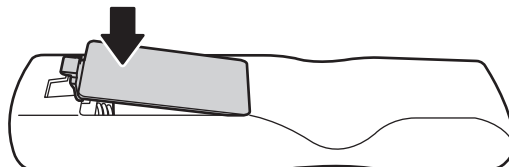

- Make sure that the battery polarities are correct when installing the batteries.
- Do not mix an old battery with a new one or different types of batteries.
- If you will not use the remote control for a long time, remove the batteries to avoid damage from battery leakage.

3.1 Remote Control

◀ Notes on Batteries

Notes on Remote Control Operation

The remote control can be used to control the projector within the ranges shown in Figure 3-1.

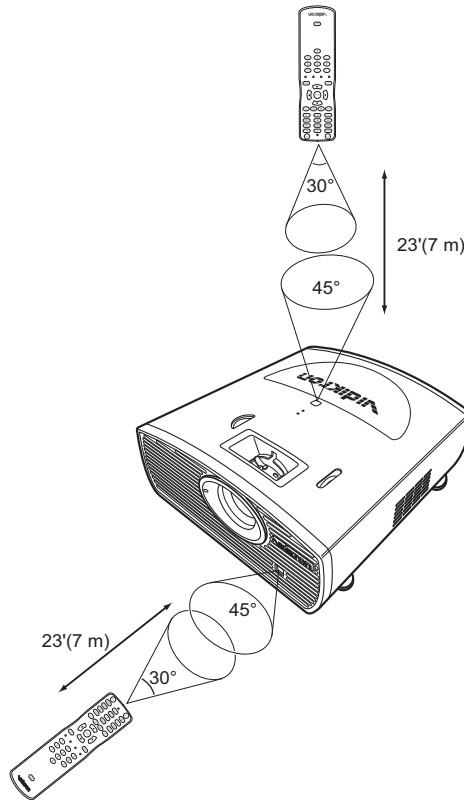

Figure 3-1. Available Range of the Remote Control



Note

The signal from the remote control can be reflected by the screen or other surfaces.

- For best results, hold the remote control within 23 feet (7m) of the back or top sensor and aligned within 30°.
- Do not drop the remote control or expose it to moisture or high temperature.
- The remote control may malfunction under a fluorescent lamp. If that occurs, move the projector away from the fluorescent lamp.
- Make sure that there is nothing obstructing the infrared beam between the remote control and the IR receiver on the projector.
- If the effective range of the remote control decreases, or it stops working, replace the batteries with new ones.
- Ambient conditions may possibly impede the operation of the remote control. If this happens, point the remote control at the projector, and repeat the operation.

Table 3-1 gives a quick overview of the Vision 15 installation process. The sections following this one provide detailed instructions.

3.2 Quick Setup



Note

Installation should be performed by a qualified custom video installation specialist.

Table 3-1. Installation Overview

Step	Procedure	For Details, Refer to page...
1	Choose a location for the projector	14
2	If installing a Vision 15ET/CineWide: Install CineWide lens base plate (optional)	20
3	Mount the projector	22
4	Connect signal sources to the Vision 15	23
5	Connect external controller to RS-232 port (optional)	28
6	Connect 12-volt trigger output to retractable screen or other, 12-volt trigger-activated equipment (optional)	29
7	Apply power to the projector	29
8	Change the OSD Language (optional)	30
9	For rear-screen and/or ceiling-mount installations, select the proper picture orientation	30
10	Primary lens adjustments: projected image size (zoom), position (shift) and focus	17, 31
11	Install CineWide anamorphic lens (optional)	33
12	CineWide lens adjustments: position, pitch (angle), geometry and focus	33
13	Projector calibration: adjust the following for each input ; save settings when finished: Aspect ratio Brightness Contrast Color level Tint Input position	42 through 47

3.3 Installation Considerations

Proper installation of your projector will ensure the quality of your display. Whether you are installing a projector temporarily or permanently, you should take the following into account to ensure your projector performs optimally.

Installation Type ➤ Choose the installation type that best suits your needs: front or rear screen, floor mount or inverted mount. Table 3-2 compares these various installation methods.

Table 3-2. Projector Installation Options

Advantages	Considerations
Front Screen, Floor Mount Installation	
<ul style="list-style-type: none"> • Easy to set up • Can be moved or changed quickly • Easy to access 	<ul style="list-style-type: none"> • Shares floor space with audience
Front Screen, Inverted Mount (ceiling) Installation	
<ul style="list-style-type: none"> • Does not take up audience space • Projector is unobtrusive • Projector cannot be accidentally moved 	<ul style="list-style-type: none"> • Installation is more permanent • Projector access is more difficult
Rear Screen, Floor Mount Installation	
<ul style="list-style-type: none"> • Projector is completely hidden • Projector is easily accessed • Usually good ambient light rejection 	<ul style="list-style-type: none"> • Requires separate room • Installation cost is usually higher
Rear Screen, Inverted Mount (ceiling) Installation	
<ul style="list-style-type: none"> • Projector is completely hidden • Usually good ambient light rejection 	<ul style="list-style-type: none"> • Requires separate room • Installation cost is usually higher
Rear Screen, Floor Mount with Mirror	
<ul style="list-style-type: none"> • Projector is completely hidden • Usually good ambient light rejection • Requires less space behind screen than other rear screen installations 	<ul style="list-style-type: none"> • Requires separate room • Installation cost is usually higher

Ambient Light ➤ In general, minimize or eliminate light sources directed at the screen. Contrast ratio in your images will be noticeably reduced if light directly strikes the screen, such as when a shaft of light from a window or floodlight falls on the image. Images may then appear washed out and less vibrant.

Throw distance is the distance measured from the front of the projector to the screen. This is an important calculation in any projector installation as it determines whether or not you have enough room to install your projector with a desired screen size and if your image will be the right size for your screen.

◀ **Throw Distance**

You can quickly estimate the throw distance by taking the width of the screen and multiplying it by the lens throw ratio; see Figure 3-2. The result of this calculation tells you roughly how far back the projector should be positioned from the screen in order to project a focused image large enough to fill the screen.

Estimating Throw Distance

Throw Distance (TD) = Screen Width (w) x Lens Throw Ratio

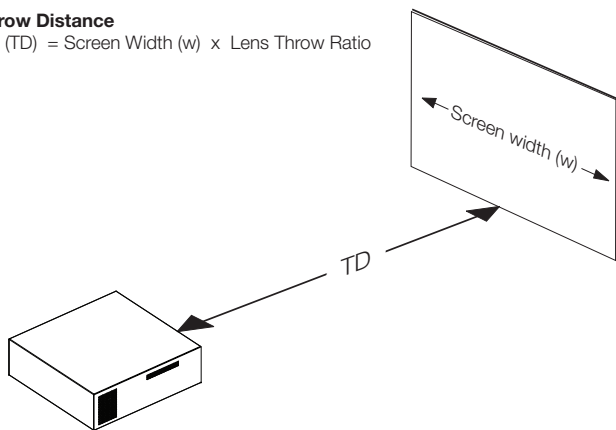

Figure 3-2. Estimating Throw Distance

Table 3-3 gives the throw ratios for the Vision 15 Series.

Table 3-3. Throw Ratios for the Vision 15 Series

Projector Model	Throw Ratio with Primary Lens Only	Throw Range in inches, with 72.6x40.8-inch (1.78:1) Screen		Throw Ratio with Primary Lens and Anamorphic Lens	Throw Range in inches, with 96x40.8-inch (2.35:1) Screen	
		Minimum	Maximum		Minimum	Maximum
Vision 15	1.36 - 1.70	98.74	123.42		(n/a)	
Vision 15ET	1.69 - 2.13	122.69	154.63		(n/a)	
Vision 15ET/ CineWide		(n/a)		1.69 - 2.13	162.24	204.48

Vertical and Horizontal Position ➤

Proper placement of the projector relative to the screen will yield a rectangular, perfectly-centered image that completely fills the screen.

Typically (but not always), the projector is positioned perpendicular to the screen and in such a way that the lens center and screen center are aligned with each other, as shown in Figure 3-3.

Ceiling Installation

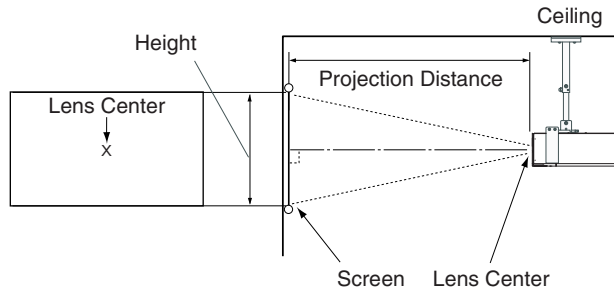

Floor Installation

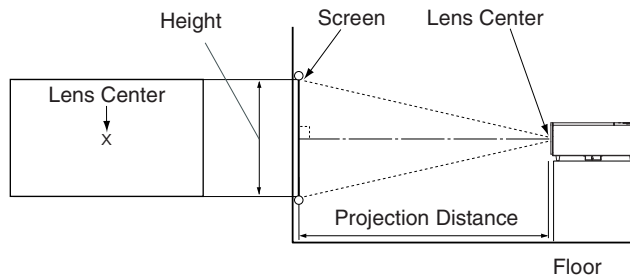
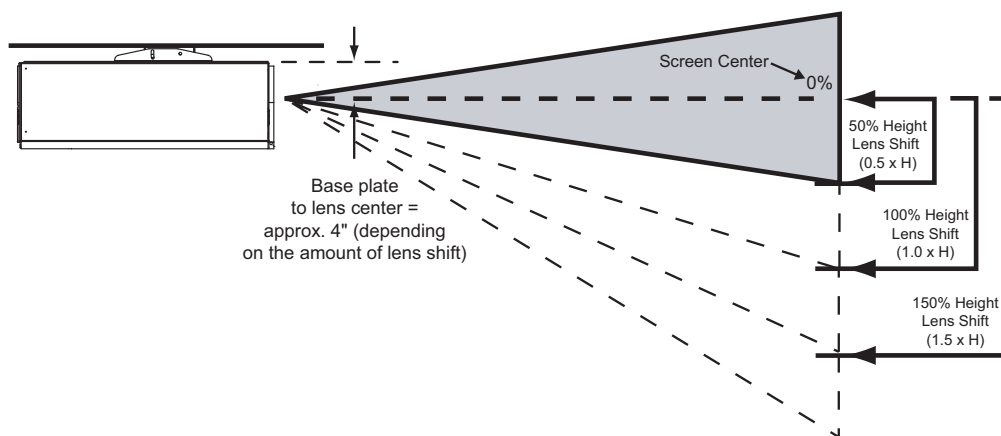

Figure 3-3. Projector Placement

If it is not possible to align the projector and screen as shown in Figure 3-3, you can use the lens shift controls to center the image on the screen. Lens shift is generally expressed as a percentage of the screen height or width, as shown in Figure 3-4 and Figure 3-5.

◀ Vertical and Horizontal Lens Shift



Note: This is a general example of lens shift. Lenses vary in their shift capabilities. **No particular lens or projector is shown in this example.**

Figure 3-4. Vertical Lens Shift (Example only)

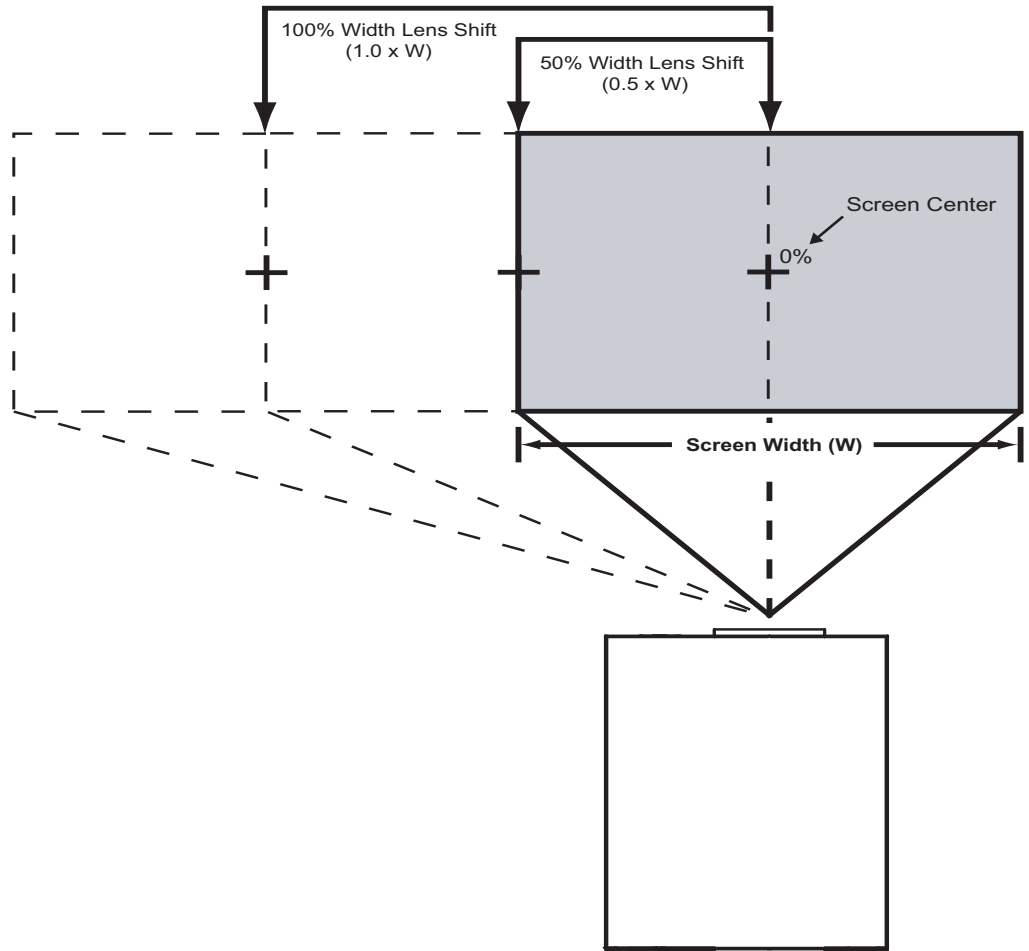

Note: This is a general example of lens shift. Lenses vary in their shift capabilities. **No particular lens or projector is shown in this example.**

Figure 3-5. Horizontal Lens Shift (Example only)

Table 3-4 gives the lens shift limits for the Vision 15, as percentages and absolute measurements with a 96 x 54 inch (1.78:1) screen.

Table 3-4. Vertical and Horizontal Lens Shift Limits

		Vision 15	Vision 15ET
Lens Shift Limits, as Percentages of Screen Height or Width (Notes 1 and 2)			
Vertical (Notes 2 and 3)	Up	50%	50%
	Down	55%	75%
Horizontal (Note 2)	Left	7.5%	
	Right	7.5%	
Lens Shift Limits in Inches, with a 96-by-54 inch (1.78:1) Screen			
Vertical	Up	27.00	27.00
	Down	29.70	40.50
Horizontal	Left	7.20	
	Right	7.20	
Notes:			
1. With no vertical or horizontal lens shift, the lens center and screen center are aligned with each other.			
2. Vertical shift limits are percentages of the screen height. Horizontal shift limits are percentages of the screen width.			
3. Vertical lens shift figures apply to ceiling mount configurations. For floor installations (where the projector is upright), reverse the up/down vertical offset percentages.			

In rear-screen applications where space behind the projector is limited, a mirror may be used to fold the optical path, as shown in Figure 3-6. The position of the projector and mirror must be accurately set. If you are considering this type of installation, contact your dealer for assistance.

◀ **Folded Optics**

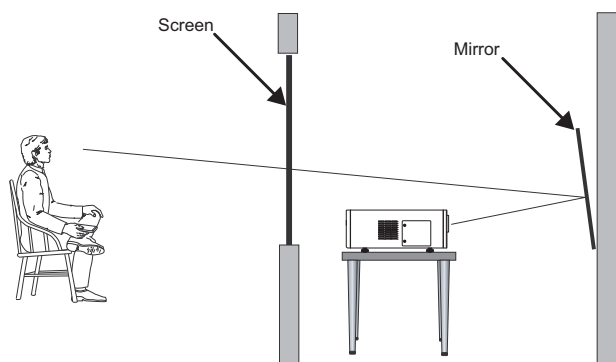

Figure 3-6. Folded Optics

Other Considerations ➤

Other considerations and tips that can help improve your installation:

- Keep the ambient temperature constant and below 35°C (95°F). Keep the projector away from heating and/or air conditioning vents. Changes in temperature may cause drifts in the projector circuitry, which may affect performance.
- Keep the projector away from devices that radiate electromagnetic energy such as motors and transformers. Common sources of these include slide projectors, speakers, power amplifiers and elevators.

3.4 Installing the Optional CineWide Lens Base Plate

If you are installing a Vision 15ET/CineWide, proceed as follows to install the CineWide anamorphic lens base plate. Otherwise, skip this step and proceed with **Mounting the Vision 15** (page 22).



Note

1. Do not install the CineWide lens yet, only the fixed CineWide base plate. You will install the CineWide lens after you install the projector and adjust the primary lens.

2. Some components shipped with your projector may differ slightly from what is shown in these instructions.

To install the fixed CineWide base plate on a Vision 15ET/CineWide:

1. Place the projector upside down on a blanket or other soft surface.
2. Line up the three mounting holes on the CineWide base plate with those on the bottom of the projector.
3. **If you are mounting the Vision 15ET/CineWide on a ceiling:** Line up the three holes on the projector ceiling mounting plate (included with the projector ceiling mount kit) with those on the bottom of the projector.
4. Secure the CineWide base plate (and ceiling mounting plate, if needed) to the projector with the M4x14mm screws provided with the CineWide lens base plate. See Figure 3-7.



Caution

1. **Do not use the mounting screws provided with the ceiling mount kit.** Use only the hardware provided with the CineWide lens base plate.

2. **DO NOT OVER-TIGHTEN THE SCREWS.**

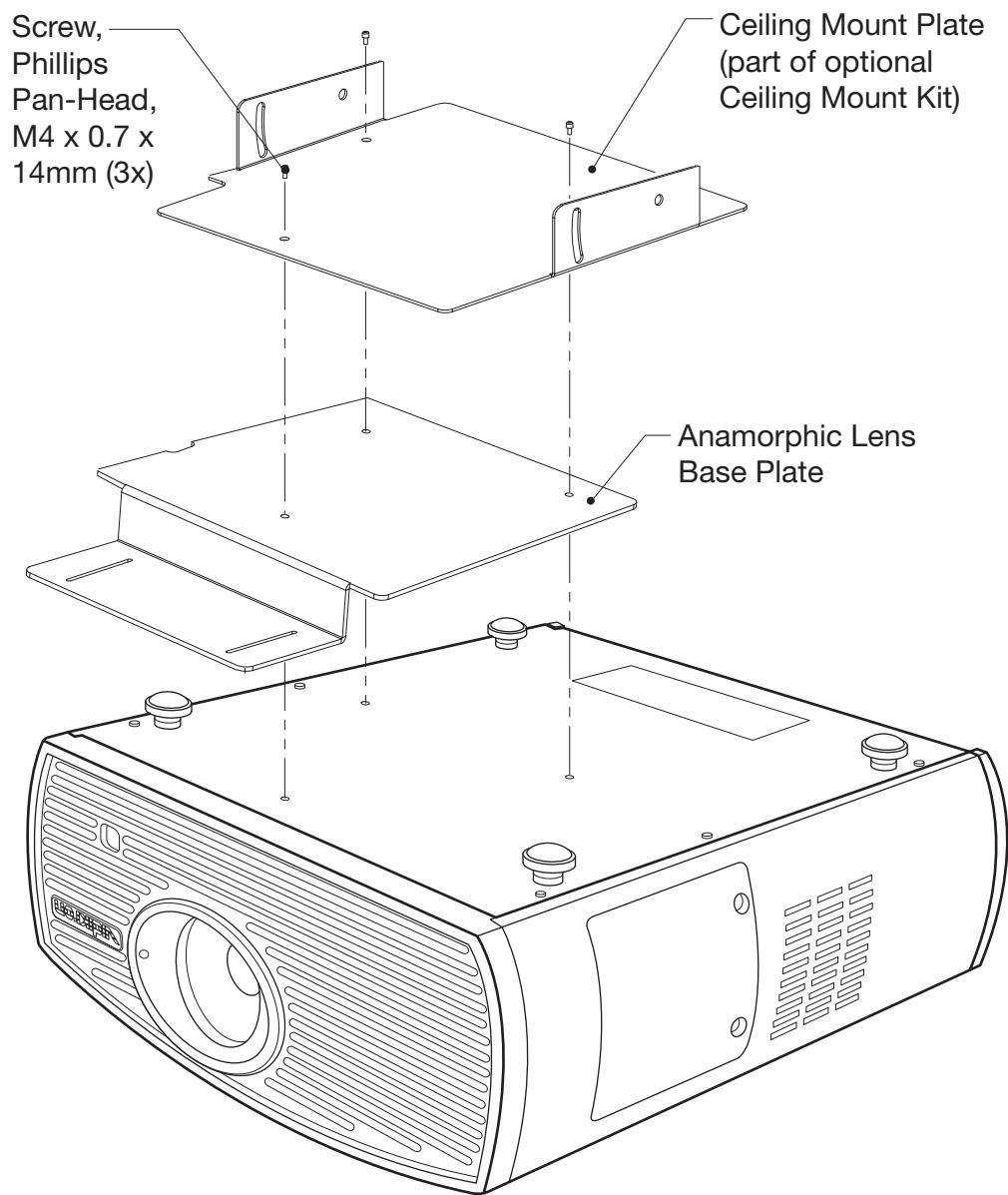

Figure 3-7. Vision 15ET/CineWide with Lens Base Plate and Ceiling Mounting Plate - Exploded View

3.5 Mounting the Vision 15

There are several methods for mounting the projector. Depending on your chosen installation, one method may be more suitable than another.

Floor Mounting (Upright) ➤ In typical front and rear screen installations, the projector can be mounted to a secure and level surface such as a table or cart. Carts are useful when moving a projector during a presentation or from site to site. If possible, lock the wheels when it's in position to prevent it from being moved during a presentation.

Ceiling Mounting (Inverted) ➤ For fixed installations, and for those that want the projector out of sight or have a limited space for projector and audience, you can invert the Vision 15 and suspend it from the ceiling using a specially-designed ceiling mount fixture.



Note

Use only the Vidikron-approved ceiling mount kit designed for your projector. Install the mount kit according to the instructions provided with it.

The projector can also be inverted and placed in an enclosure above and behind the viewing area. Install four feet on the inside bottom surface of the enclosure on which the projector can rest. A variety of materials can be used for this purpose (for example, rubber crutch tips or turntable feet).

Adjusting the Projector Height or Projection Angle ➤

When the Vision 15 is installed upright, you can adjust the projector height or projection angle by turning the four adjustable feet on the bottom of the projector; see Figure 3-8. This is useful for correcting the angle of projection when the projector is placed on an uneven surface or when the screen is at an angle. You can tilt the projector up to five (5) degrees up or down by adjusting the feet.

The feet are connected to threaded bolts; turn them clockwise to raise the projector or counterclockwise to lower it.



Note

*Tilting the projector may cause keystone distortion. To correct this, refer to **Installation** on page 45.*

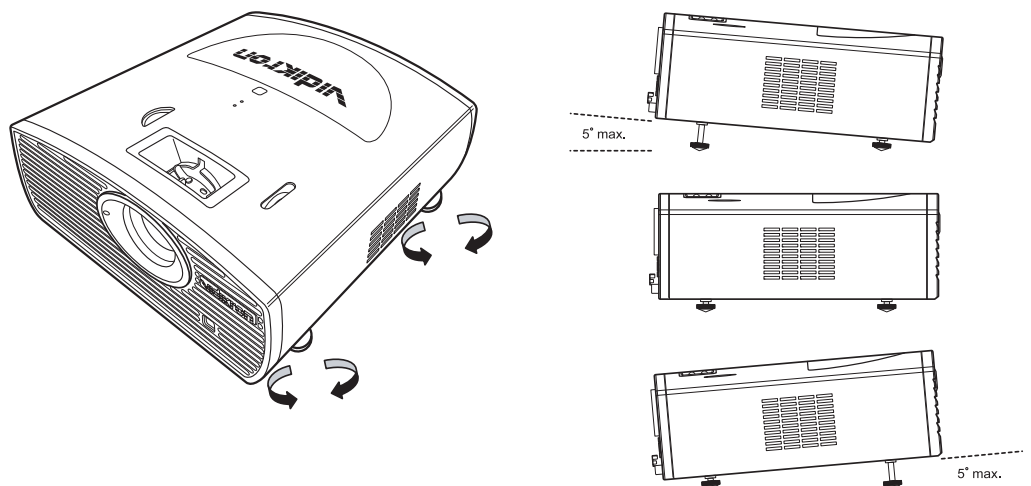

Figure 3-8. Adjusting the Feet

Proceed as follows to connect the Vision 15 to your video sources, external controller(s) – if present – and AC power.

When connecting your equipment:

- Turn off all equipment before making any connections.
- Use the correct signal cables for each source.
- Ensure that the cables are securely connected. Tighten the thumbscrews on connectors that have them.

To access the connector panel, pull firmly on the cable access cover to open it.

Connect your video sources to the Vision 15 as shown and described in the sections that follow.

HDMI/DVI Connections: See Figure 3-9.



Tip

Use the HDMI input whenever possible. This ensures the highest video quality because the signal is carried in the digital domain throughout the entire signal path, from source component output into the projector.

3.6 Connections to the Vision 15

◀ Connector Panel Access

◀ Connecting Source Components to the Vision 15

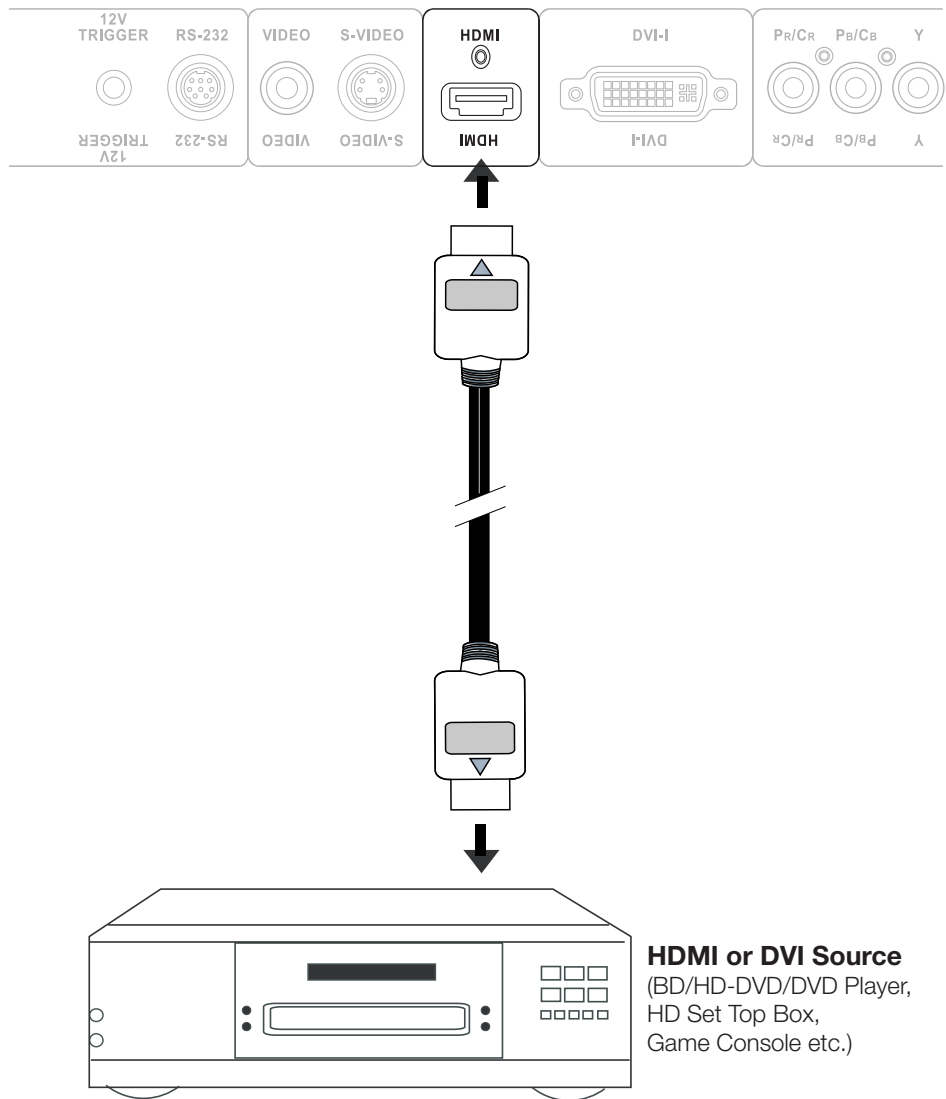

Figure 3-9. HDMI/DVI Source Connections

RGB Connections: Connect your personal computer or other RGB source (DVD player or HD set top box) to the **DVI-I** input; see Figure 3-10.

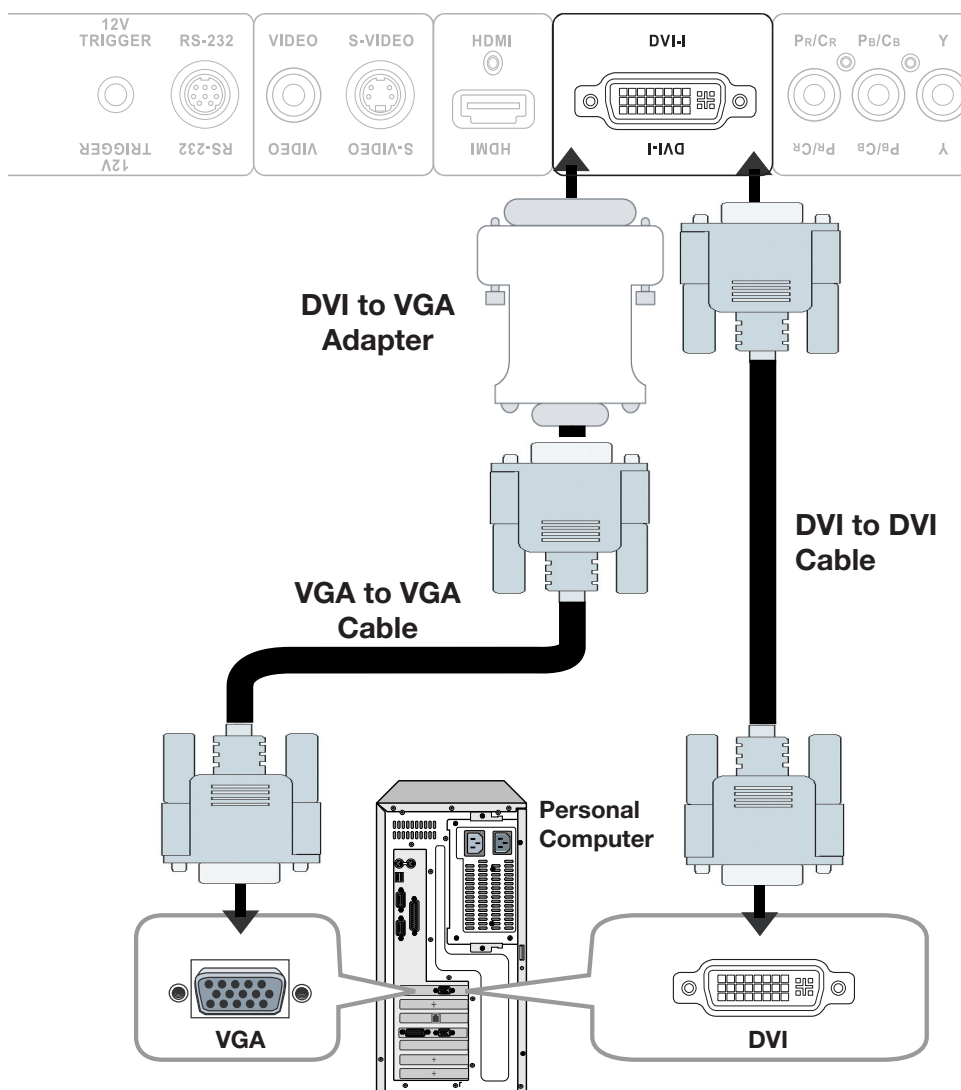

Figure 3-10. RGB Connections



Note

1. Refer to **Computer Signal Compatibility** on page 65 for a list of computer signals compatible with the Vision 15. Use with signals other than those listed may cause some functions not to work.
2. Some Macintosh computers may require a Macintosh video adapter. Contact your nearest authorized service center or dealer.
3. This Vision 15 may not be able to display images from notebook computers in simultaneous (CRT/LCD) mode. Should this occur, switch the notebook computer to "CRT only" mode. If you are unsure how to do this, refer to your notebook computer's user manual.

Component Video Connections: Connect your component video source (DVD player or HD set top box) to the **COMP** input as shown in Figure 3-11.

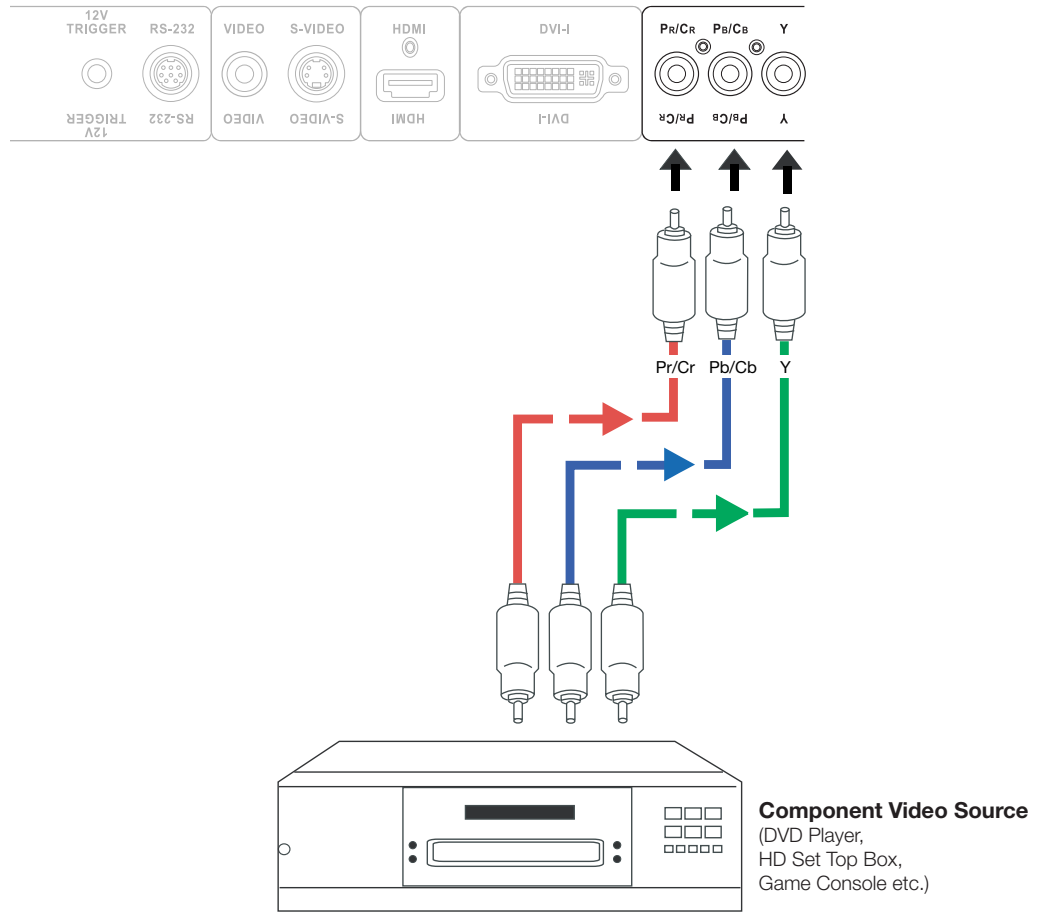

Figure 3-11. Component Video Connections

S-Video/Composite Video Connections: Connect your S-Video and composite video sources to the Vision 15 as shown in Figure 3-12.

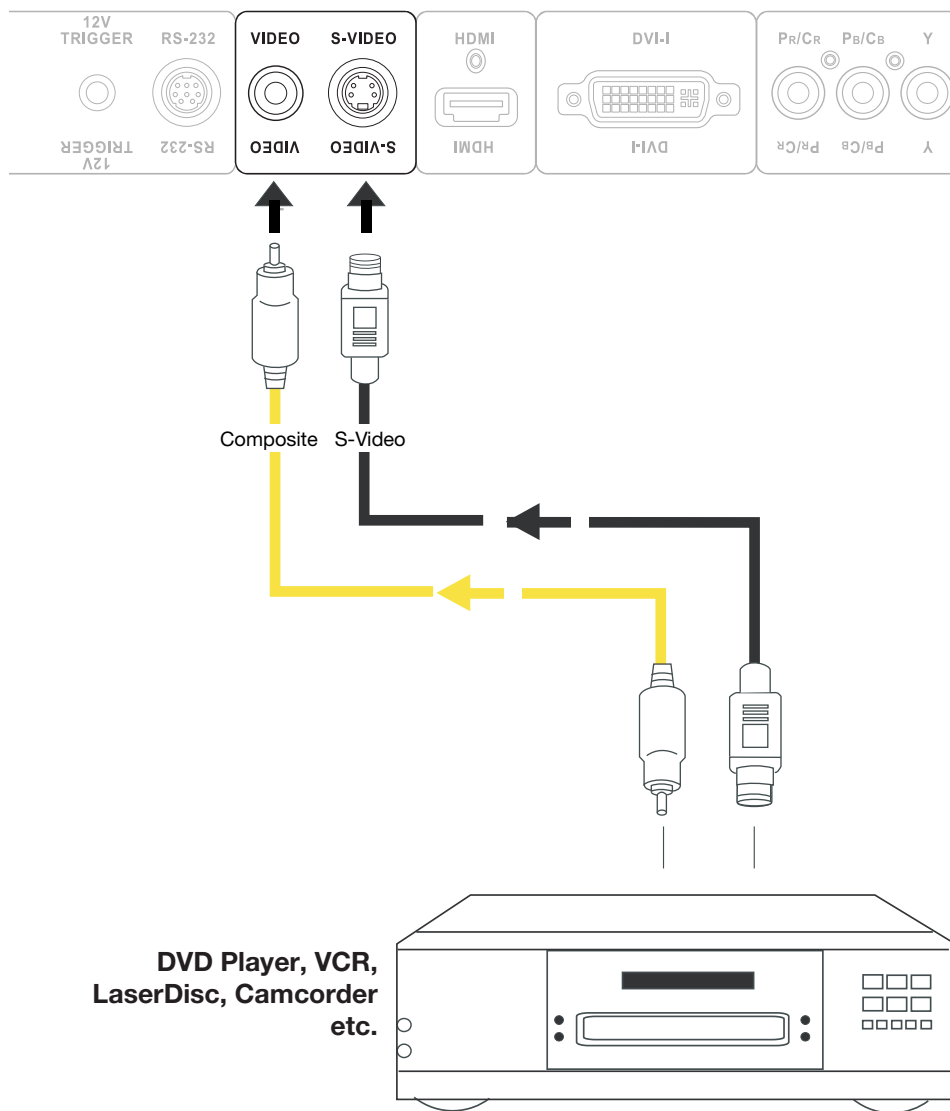

Figure 3-12. Composite and S-Video Connections

RS-232 Controller Connection

Use the communication cable supplied with the projector to connect a PC or home theater control/automation system (if present) to the RS-232 port on the Vision 15; see Figure 3-13.

For more information about using this connection, refer to **Serial Communications** on page 59.

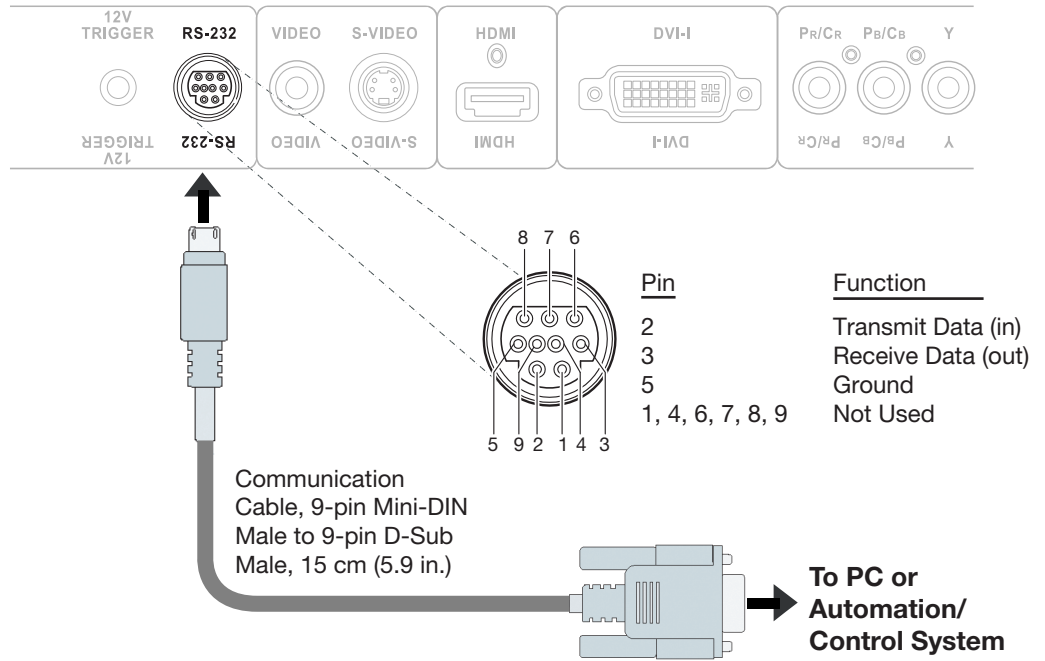

Figure 3-13. RS-232 Control System Connection

If your home theater contains a retractable screen, screen mask or other 12-volt trigger-activated equipment, connect it to the 12-volt trigger output as shown in Figure 3-14.

◀ Connecting 12-Volt Trigger Output to External Theater Equipment

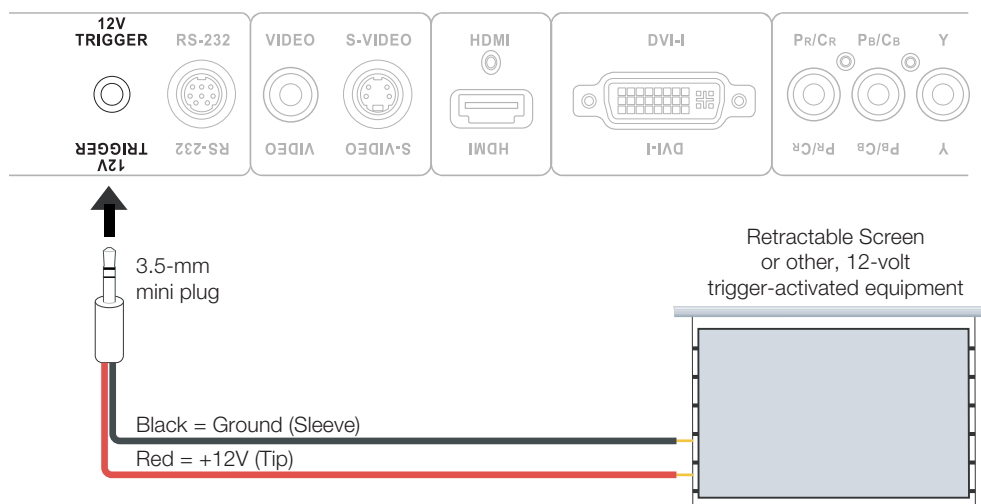
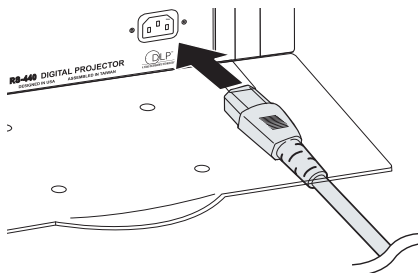

Figure 3-14. Connecting the 12-Volt Trigger Output to Other Equipment

1. Turn on your source components.
2. Plug the female end of the power cord into the AC receptacle on the rear of the Vision 15 (AC 100V ~ 240V). (The Vision 15 ships with various types of AC power cords. Choose the one that is appropriate to your locale.)
3. Connect the other end to your AC power source. The power indicator lights blue to indicate that the Vision 15 is in "standby" mode.
4. Press the **ON** button on the remote control to turn on the projector. The power indicator turns off.
5. After a brief warm-up period (approximately 10 seconds), the Vision 15 will start projecting.



3.7 Turning on the Power

3.8 Changing the OSD Language

The Vision 15 OSD language is initially set to English, but can also display the menus in French, Spanish, Italian or German. To change the OSD language:

1. Press **MENU**.
2. Select **Installation** from the Main Menu and press **ENTER**.
3. Select **Language** from the Installation Menu and press **ENTER**.
4. Press **▲** or **▼** to highlight the desired language and press **ENTER**.

3.9 Adjusting the Picture Orientation

By default, the Vision 15 is configured for a "floor/front" installation, in which the projector is installed upright and in front of the screen. If it is installed behind the screen and/or mounted on a ceiling, you must change the picture orientation. To do this:

1. Press **MENU** on the remote control.
2. Select **Installation** from the Main Menu and press **ENTER**.
3. Select **Orientation** from the Installation Menu and press **ENTER**.
4. Choose **Floor Rear**, **Ceiling Front** or **Ceiling Rear** to match the installation method.

The Vision 15 gives you a great deal of control over the picture size, position and focus. Figure 3-15 shows the location of the focus and zoom controls; Figure 3-16 shows the location of the lens shift controls.

To focus the projected image, rotate the focus ring left or right.

To make the picture larger (zoom in), rotate the zoom ring to the left (toward the Vidikron logo). To make the picture smaller (zoom out), rotate the zoom ring in the other direction.

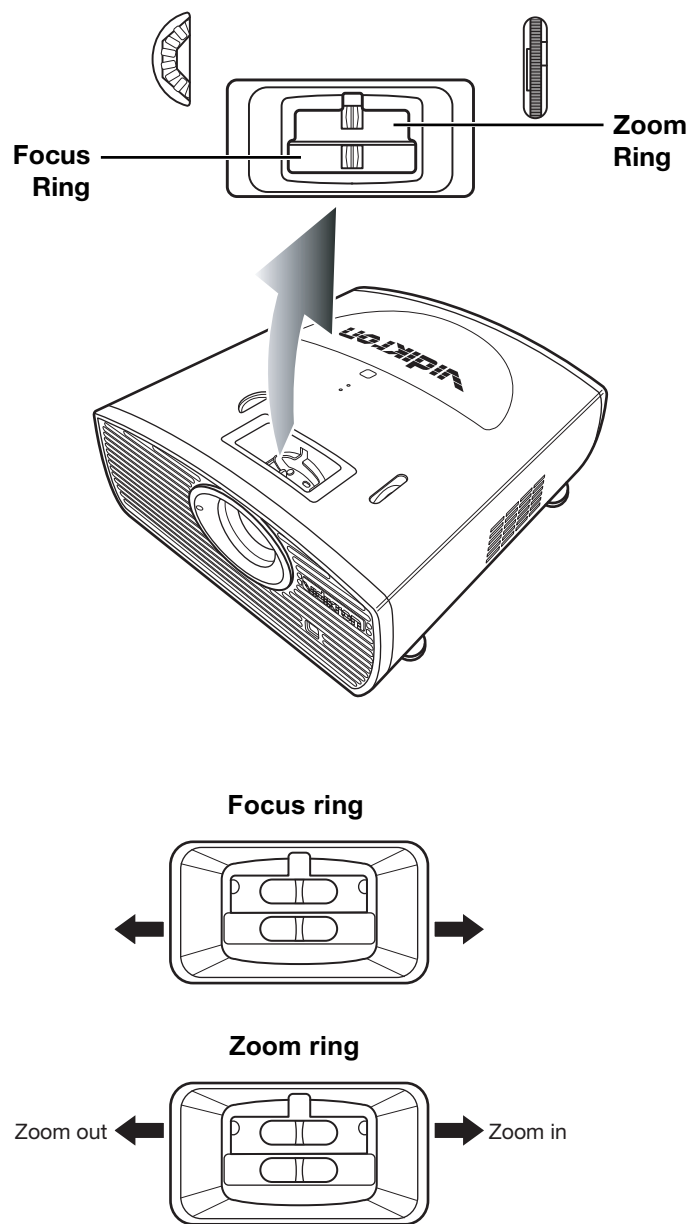

Figure 3-15. Focus and Zoom Controls

3.10 Primary Lens Adjustments

◀ Focus and Zoom

Shift ➤ To change the projected image position, rotate the vertical and/or horizontal lens shift dials.



Caution

Do not force the lens shift dials beyond their respective ranges. This may cause the projector to malfunction.

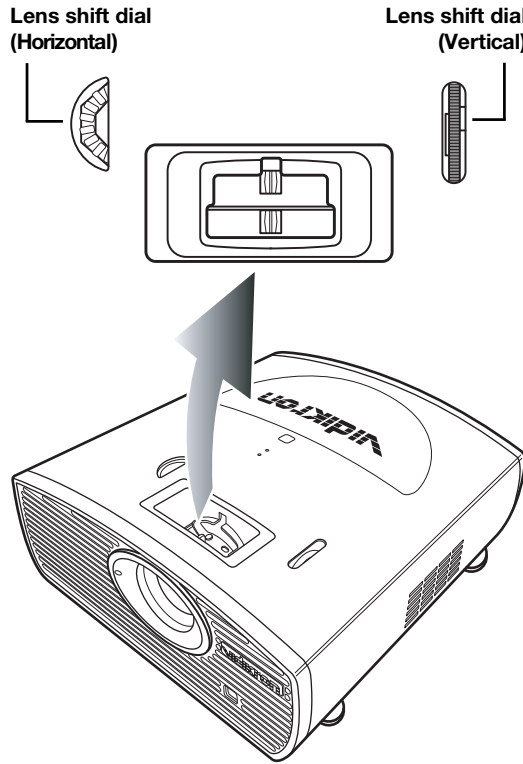

Figure 3-16. Vertical and Horizontal Lens Shift Controls

If you are installing a Vision 15ET/CineWide, proceed as follows to install and adjust the anamorphic lens.



Note

It is extremely important that the primary lens is properly adjusted before you install the anamorphic lens. Ensure that the image from the primary lens is perfectly centered on the screen.

The CineWide anamorphic lens mount kit consists of everything shown in Figure 3-17. Some components shipped with your projector may differ slightly from what is shown in these instructions.

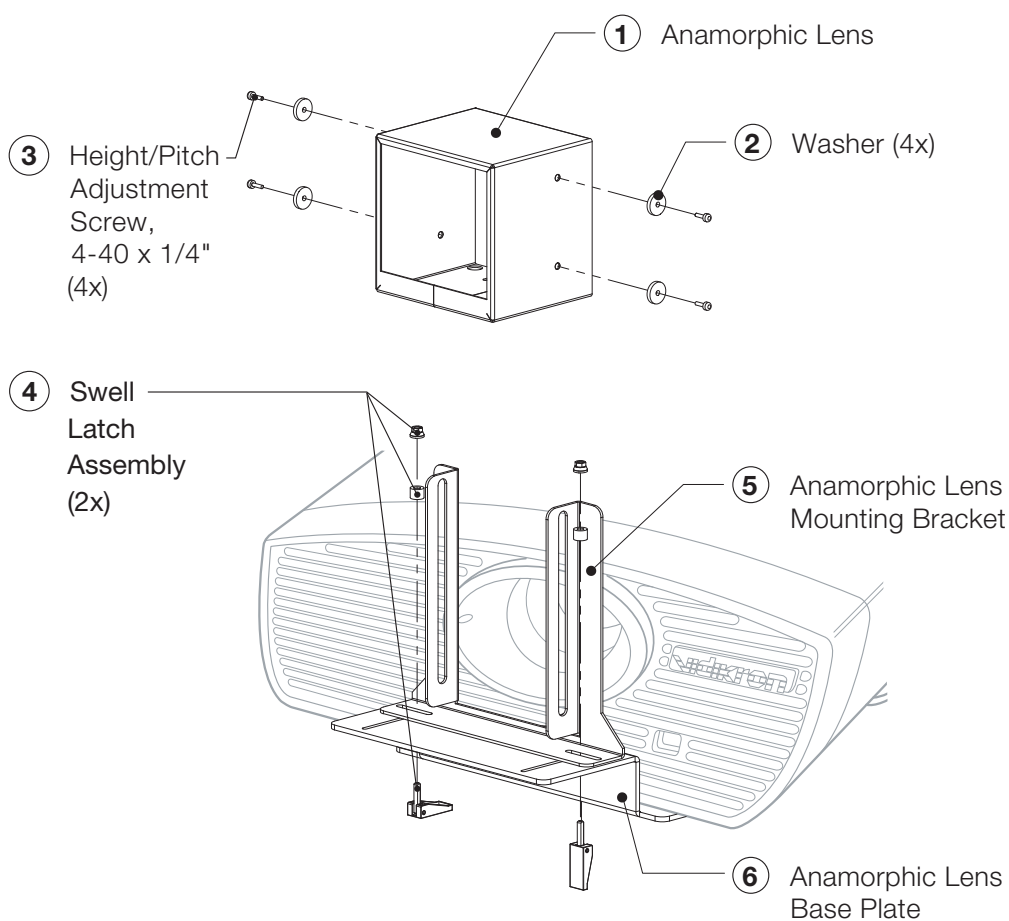

Figure 3-17. Anamorphic Lens Mounting Assembly - Exploded View

1. Use the Height/Pitch Adjustment Screws (2) and Washers (3) to attach the Lens Mounting Bracket (5) to the Anamorphic Lens (1).
2. Remove the nut and rubber collar from each Swell Latch Assembly (4).

- Secure the lens (with the mounting bracket attached) to the Lens Base Plate (6) using the swell latches.



Tip

To avoid clipping the corners of the image, position the anamorphic lens as close as possible to the primary lens.

Adjusting the Lens Height and Angle:

- Project a white field on the screen.
- Loosen the four Height/Pitch Adjustment Screws just enough to allow vertical movement of the lens assembly.
- Slowly move the anamorphic lens into place so that there are no shadows on the top or bottom of the screen:

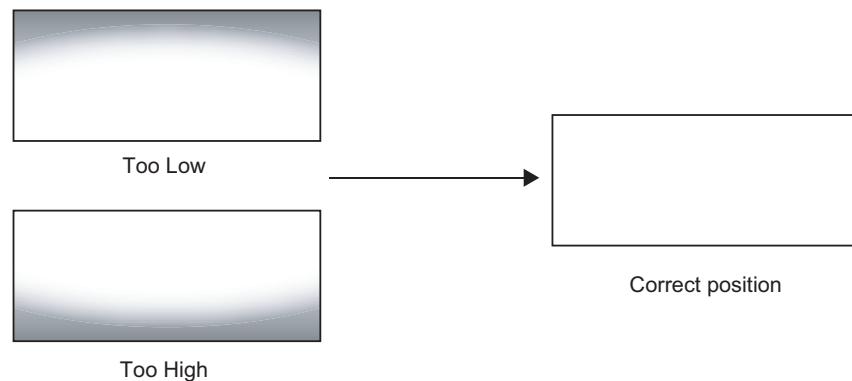

- Then, adjust the anamorphic lens angle so that the projected image is rectangular:

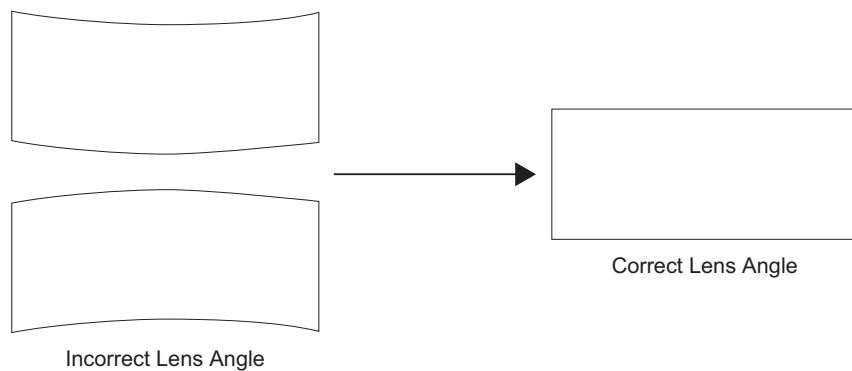

The anamorphic lens will almost always be angled with respect to the projector; this is normal.

- When the height and angle are properly set, tighten the Height/Pitch Adjustment Screws to secure the lens in place.



Note

There may be some pincushion distortion even after the lens is properly adjusted, especially at shorter throw distances. If this is the case, Vidikron recommends that you slightly over-scan the image into the screen frame area to mask the distortion.

- Press the **MENU** button on the remote control to display the Main Menu. To select a menu item, use the ▲ and ▼ buttons on the remote control to highlight it. Press **ENTER** to confirm your selection.
- Use the arrow buttons to select menu items or change settings.
- Press **EXIT** to return to the previous menu.
- Press **MENU** to turn off the OSD menu. (When the Main Menu is displayed, pressing **EXIT** also turns off the menu.)

The Vision 15 OSD menus are arranged hierarchically, as shown in Figure 4-1. Depending on the selected input source and signal characteristics, some menu options may not be available.

4.1 Using the On-Screen Menus

Source Select	Video		
	S-Video		
	Component		
	HDMI		
	DVI-D		
	DVI-A		
Picture Adjust	Picture Memory	ISF Night, ISF Day or Custom	
	Brightness		
	Contrast		
	Color		
	Tint		
	Sharpness	0 ... 6	
	Gamma	1.5, 1.8, 2.0, 2.2, 2.35, 2.5	
	Color Temp.	5400 K, 6500 K, 7500 K or 8500K	
	Color Space	Auto, HDTV, SDTV, RGB-Video or RGB-PC	
	BrilliantColor™	On or Off	
	Black Level	0 IRE or 7 IRE	
	Save Settings		
	Reset to Defaults		
Aspect Ratio	16:9		
	4:3		
	Letterbox		
	IntelliWide		
	Cinema		
	IntelliWide 2.35	(Vision 15ET/CineWide only)	
Installation	Language	English, French, Spanish, German or Italian	
	Orientation	Floor Front, Floor Rear, Ceiling Front or Ceiling Rear	
	Keystone	V. Keystone H. Keystone	
	Overscan	Overscan Type	
		Overscan Adjust (0 ... 5)	
	YUV/RGB Adjust (Component and DVI-A signals only)	H. Position	
		V. Position	
		Clock	
		Phase	
	Reset		
	OSD Timeout	0, 5, 15 or 60 sec.	
Vertical Correction (Vision 15ET/CineWide only)			
Information	Source		
	Resolution		
	H. Frequency		
	V. Frequency		
	Aspect Ratio	(read only)	
	Picture Memory		
	Lamp Hours		
	Firmware		
	Serial		
	Setup	Lamp Power	180W or 230W
Lamp Reset			
Sync Threshold (Component input only)			
Source Select		Auto or Manual	
Film Mode		Auto or Off	
DNR			
Background Color		Black or Blue	
12V Trigger		Normal or CineWide	
Factory Reset		Yes / No	
ISF		Picture Memory	ISF Night, ISF Day or Custom
	Brightness		
	Contrast		
	Color		
	Tint		
	Sharpness	0 ... 6	
	Gamma	1.5, 1.8, 2.0, 2.2, 2.35, 2.5	
	Color Temp.	5400 K, 6500 K, 7500 K or 8500K	
	BrilliantColor™	On or Off	
	Black Level	0 IRE or 7 IRE	
	White Balance	R/G/B Gain R/G/B Offset	
	DNR	0 ... 16	
	Save Settings		
Blue Image	On or Off		
Splash Screen Timer	0, 5, 15 or 60 sec.		
Reset to Defaults			

Figure 4-1. Vision 15 OSD Menu Structure

Main Menu ➤ The Main Menu is the starting point for accessing all projector functions. (You must enter a passcode to access the ISF menu.)

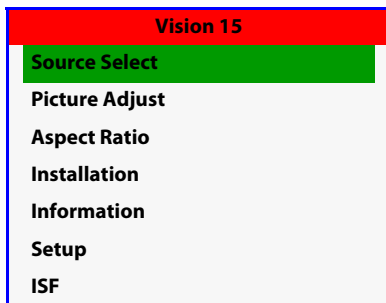

Choose Source Select from the Main Menu to switch video sources.

The active source is indicated by an arrow to its left; in this example, Video is the active source. To select a different source, use the ▲ or ▼ button to highlight it and press **ENTER**.

◀ **Source Select**

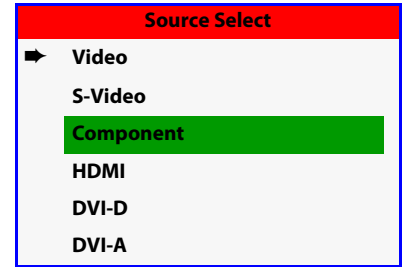

Use the controls in the Picture Adjust menu to calibrate your Vision 15 for optimum picture quality. To access the Picture Adjust menu, press **MENU**, highlight Picture Adjust and press **ENTER**.

To adjust a setting, use the ▲ or ▼ button to highlight it and press **ENTER**. Use the ◀ or ▶ button to change the setting. When finished, press **EXIT**.

The Vision 15 has been designed to incorporate setup and calibration standards established by the Imaging Science Foundation (ISF). The ISF has developed carefully crafted, industry-recognized standards for optimal video performance and has implemented a training program for technicians and installers to use these standards to obtain optimal picture quality from Vidikron video display devices. Accordingly, Vidikron recommends that setup and calibration be performed by an ISF certified installation technician.

All signal types require separate processing. Therefore, you need to calibrate each input separately.

Although it may be possible to obtain satisfactory picture quality using the naked eye and regular program material, Vidikron recommends using the following calibration tools for best results:

- External test pattern source – Ovation Multimedia, Digital Video Essentials or AVIA test DVD or equivalent.
- A blue filter (provided with many test DVDs), for color level and tint adjustments.

Connect your test pattern source to the input that you are calibrating and proceed as follows. **Perform the adjustments in the order listed here.**

Picture Memory: For each input, the Vision 15 lets you store picture quality settings as presets that you can recall at a later time. You can create up to three presets per input and resolution, to accommodate changing lighting conditions or viewer preferences.

To recall a picture memory preset, highlight Picture Memory in the Picture Adjust menu and press **ENTER**. Then, press ▲ or ▼ to select “Custom,” “ISF Night” or “ISF Day” and press **ENTER** again.

◀ **Picture Adjust**

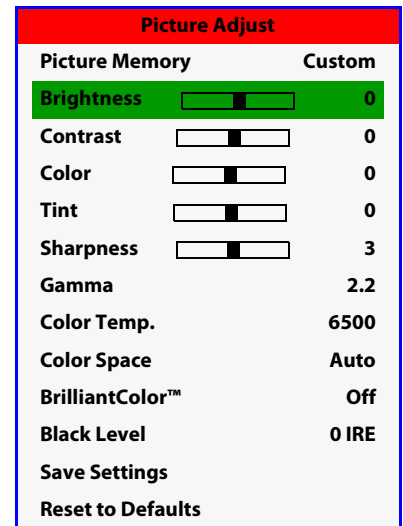

Brightness: On your external test pattern source, select a PLUGE pattern. (PLUGE is an acronym for "Picture Line-Up Generation Equipment.") Figure 4-2 shows a typical PLUGE pattern.

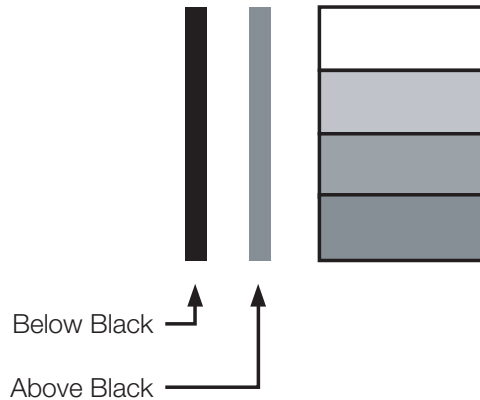

Figure 4-2. Typical PLUGE Pattern for Adjusting Brightness

PLUGE patterns vary but generally consist of some combination of black, white and gray areas against a black background. The example above includes two vertical bars and four shaded boxes.

Select Brightness from the Picture Adjust menu and press **ENTER**. Adjust the level so that:

- The darkest black bars disappear into the background.
- The dark gray areas are barely visible.
- The lighter gray areas are clearly visible.
- The white areas are a comfortable level of true white.
- The image contains only black, gray and white (no color).

Contrast: On your external test pattern source, select a stepped, gray-bar pattern like the one shown in Figure 4-3.

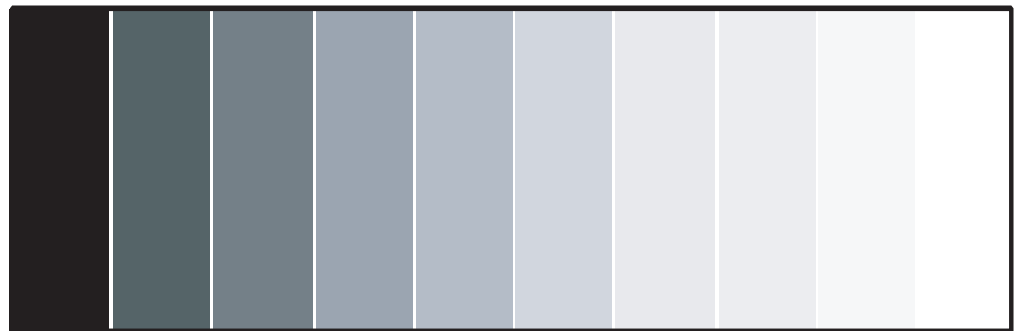

Figure 4-3. Typical Gray Bar Pattern for Adjusting Contrast

Select Contrast from the Picture Adjust menu and press **ENTER**. Adjust the contrast to a point just below which the white rectangle starts to increase in size.



Note

Brightness and Contrast controls are interactive. A change to one may require a subtle change to the other in order to achieve the optimum setting.

Color: On your external test pattern source, select a color bar pattern like the one shown in Figure 4-4.

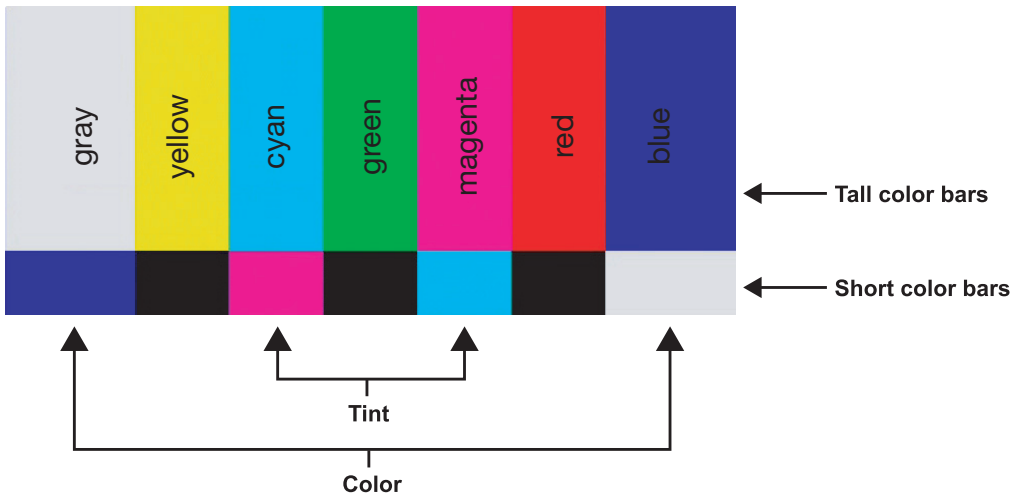
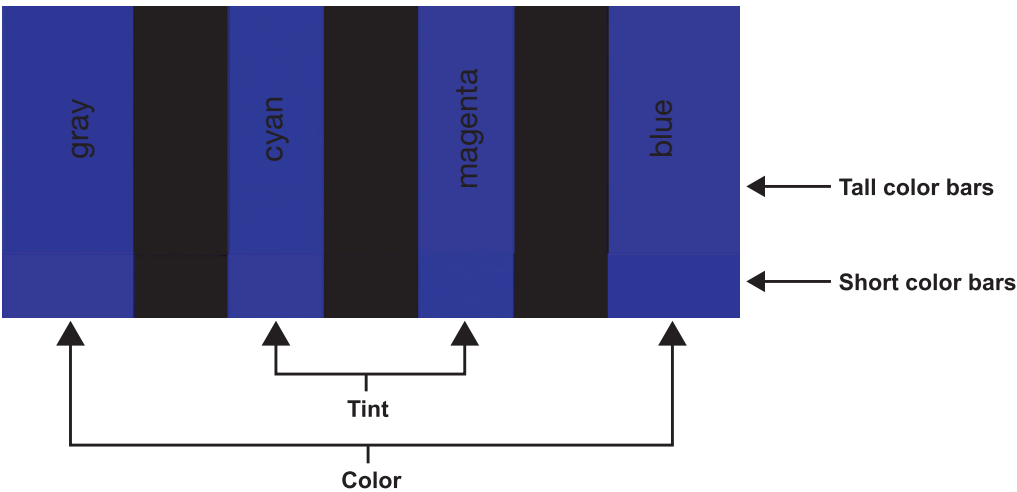

Figure 4-4. Typical Color Bar Pattern for Adjusting Color Saturation and Tint

Select Color from the Picture Adjust menu and press **ENTER**. While looking at the color bar pattern through a blue filter, adjust the color saturation level until the outermost (gray and blue) color bars appear to be a single shade of blue:



Tint: Tint or “hue” is essentially the ratio of red to green in the color portion of the image. When tint is decreased, the image appears redder; when it is increased the image appears greener. To set the tint, select Tint from the Adjustment menu and press **ENTER**. While looking at the color bar pattern through a blue filter, adjust the tint level until the cyan and magenta color bars (on either side of the green bar) appear to be a single shade of blue.

**Note**

Like the Brightness and Contrast controls, the color and tint controls are interactive. A change to one may require a subtle change to the other in order to achieve the optimum setting.

Sharpness: “Sharpness” is the amount of high-frequency detail in the image. To adjust sharpness, select Sharpness from the Picture Adjust menu and press **ENTER**. On your external test pattern source, select a pattern like the one shown in Figure 4-5. Adjust as needed, looking for white edges around the transitions from black to gray and differently-sized lines in the “sweep” patterns at the top and bottom. Lower the sharpness setting to eliminate them.

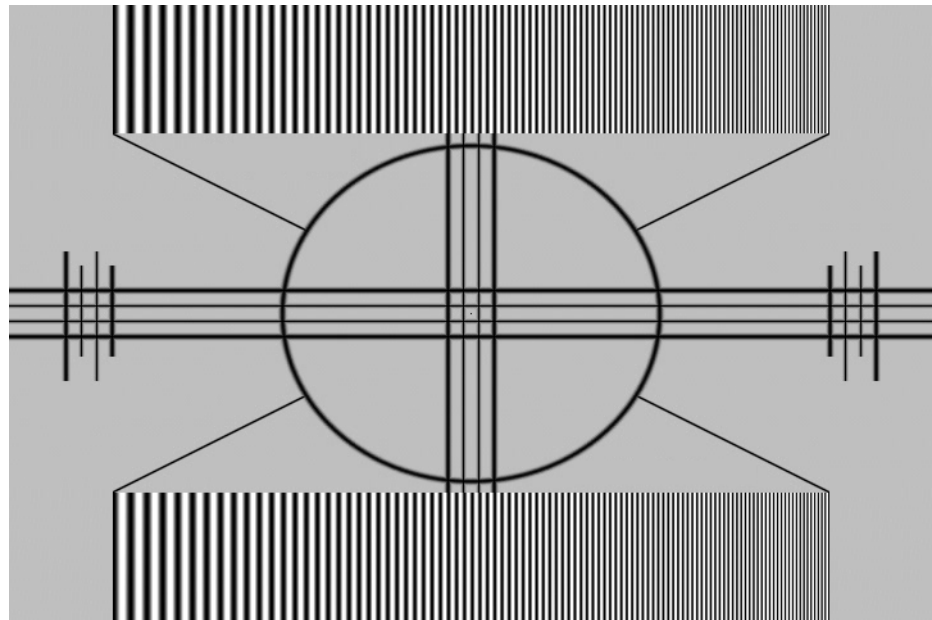

Figure 4-5. Typical Test Pattern for Adjusting Sharpness

Gamma: The normal gamma setting of 2.2 is correct for almost all signals and conditions. If excess ambient light washes out the image and it becomes difficult or impossible to see details in dark areas, lower the gamma setting to compensate. This will improve contrast while maintaining good details for blacks. Conversely, if the image is washed out and unnatural, with excessive detail in black areas, increase the setting. Again, good gamma improves contrast while maintaining good details for blacks and whites.

Color Temp.: To choose a color temperature setting, select Color Temp. from the Picture Adjust menu and press **ENTER**. (Color temperature defines the “color of gray.”) The choices are 5400K, 6500K, 7500K and 8500K. The default setting, 6500K, is appropriate for most situations. Higher settings produce a “bluer” picture; lower ones impart a reddish hue to the image.

Color Space: Select Color Space from the Picture Adjust menu to choose the color space of the source signal for HDMI, RGB and component connections.

- The default setting, **Auto**, functions as follows:
 - **HDMI/DVI-D:** If the Auxiliary Video Information (AVI) infoframe contains color space and/or range data, the Vision 15 uses that information. Otherwise, for RGB sources, the Vision 15 uses the **RGB-Video** color space. For component SDTV and EDTV resolutions, **SDTV** is used. For other component video resolutions, **HDTV** is used.
 - **DVI-A:** If Hsync or Vsync signals are present, the Vision 15 uses the **RGB-PC** color space. Otherwise, **SDTV** is used for SDTV and EDTV sources, and **HDTV** for all other sources.
 - **Component:** For SDTV and EDTV resolutions, the Vision 15 uses the **SDTV** color space. For all other resolutions **HDTV** is used.

In most cases, the **Auto** setting determines the correct color space to use. If it does not, you can force the Vision 15 to use a specific color space. Choose one of the following:

- **HDTV** sets the color space matrix to that defined in ITU-R BT.709.
- **SDTV** sets the color space matrix to that defined in ITU-R BT.601.
- **RGB-PC** uses RGB color space and sets black at 0,0,0 RGB and white at 255,255,255 RGB, assuming an 8-bit image.
- **RGB-Video** uses RGB color space and sets black at 16,16,16 RGB and white at 235,235,235, assuming an 8-bit image, to correspond to the luminance values defined in digital component standards.

BrilliantColor™: Select BrilliantColor™ from the Picture Adjust menu to enable (**On**) or disable (**Off**) BrilliantColor processing, which improves brightness in grays and secondary colors by using the spoke light from the color wheel.

Black Level: Select Black Level from the Picture Adjust menu to compensate for incoming elevated black levels present in some Composite video and S-Video sources. (This control does not affect other source types.) Set it to **0 IRE** if blacks appear elevated (dark gray). If blacks appear “crushed” (too dark), set it to **7 IRE**.

Save Settings: To store changes to picture quality settings for the current input and resolution in the “Custom” Picture Memory, select Save Settings from the Picture Adjust menu. To recall this preset at a later time, press the **CUST** button on the remote control or select “Custom” from the Picture Memory menu (see above).

You should save changes to any of the following settings to a preset; otherwise they will be lost when a new input source or resolution is selected:

- Aspect ratio (saved per source)
- Picture adjustments (brightness, contrast, color saturation, tint, sharpness, gamma, color temperature, color space, BrilliantColor™ and Black Level)
- RGB/YUV signal settings (H. Position, V. Position, Clock, Phase)
- Setup menu settings (Sync Threshold, DNR, Film Mode, Lamp Power)
- White Balance settings (gain and offset)



Note

*To store changes to the ISF Night or ISF Day Picture Memory preset, select Save Settings in the ISF menu (refer to **ISF** on page 50). **You must enter a passcode to access the ISF menu.***

Reset to Defaults: To reset all picture quality settings for the current input and resolution to their factory-default values, select Reset to Defaults from the Picture Adjust menu.

Aspect Ratio ➤

To change the aspect ratio (size and shape) of the projected image, select Aspect Ratio from the Main Menu and press **ENTER**. Select the appropriate aspect ratio for your screen size and the type of program material being viewed, then press **ENTER**; refer to Table 4-1.

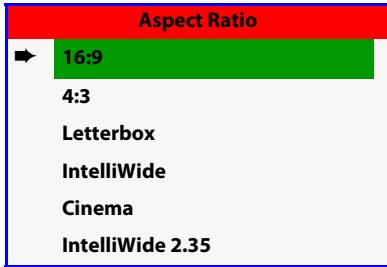

Table 4-1. Aspect Ratio Settings

Aspect Ratio Setting	Description	Aspect Ratio of Source Signal	Geometry of Projected Image	
			Standard Vision 15 or Vision 15ET (1.78:1 Screen)	Vision 15ET/CineWide (2.35:1 Screen)
16:9	16:9 linearly scales the source active image horizontally and vertically to fill the 16:9 rectangle of the designated image area.	16:9		
		4:3		
4:3	4:3 linearly scales the source active image horizontally and vertically to fill a 4:3 rectangle which is centered and the same height as the 16:9 designated image area. The remaining area is black.	16:9		
		4:3		

Table 4-1. Aspect Ratio Settings (continued)

Aspect Ratio Setting	Description	Aspect Ratio of Source Signal	Geometry of Projected Image	
			Standard Vision 15 or Vision 15ET (1.78:1 Screen)	Vision 15ET/CineWide (2.35:1 Screen)
Letterbox	With a 16:9 source image, Letterbox mode crops the top and bottom portion of the image and vertically stretches the remaining portion to fill a 16:9 image area.	16:9		
	It scales (zooms in on) a 4:3 image linearly (by the same amount on all sides) to fill a 16:9 display.	4:3		
Intelli-Wide	A 16:9 image is shrunk horizontally in the center and stretched horizontally in a NON-linear fashion (more on the sides).	16:9		
	A 4:3 image is horizontally scaled in a NON-linear fashion (more on the sides than in the center) to fit a 16:9 screen.	4:3		

Table 4-1. Aspect Ratio Settings (continued)

Aspect Ratio Setting	Description	Aspect Ratio of Source Signal	Geometry of Projected Image	
			Standard Vision 15 or Vision 15ET (1.78:1 Screen)	Vision 15ET/CineWide (2.35:1 Screen)
Cinema	Select Cinema to view 2.35 source material in its native aspect ratio.	2.35:1		
	With a 16:9 screen and a non-CineWide projector (no anamorphic lens), the upper and lower portions of the screen are masked, but the geometry of the active image area is unchanged. With a 2.35:1 screen and a CineWide-equipped projector, the video processor scales the 2.35:1 image so that the active image area fills the 16:9 chip surface, eliminating the black bars. The secondary, anamorphic lens then restores the proper geometry to the 2.35:1 image.			
Intelli-Wide 2.35	A 16:9 image is scaled NON-linearly (more on the sides than in the center) to fit a 2.35:1 screen. IntelliWide 2.35 is available only on the Vision 15ET/CineWide.	16:9		

To access the Installation adjustments, press **MENU**, then press the ▲ or ▼ button to highlight Installation and press **ENTER**. The Installation sub-menu appears. Press **EXIT** to return to the previous menu or press **MENU** to close all menus.

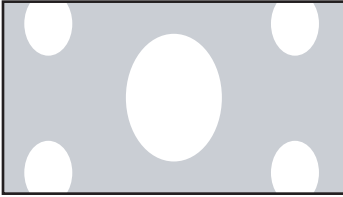
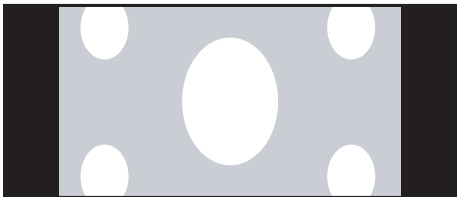
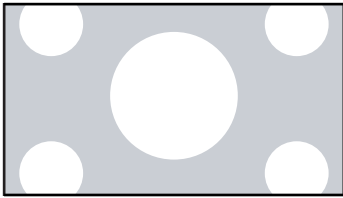
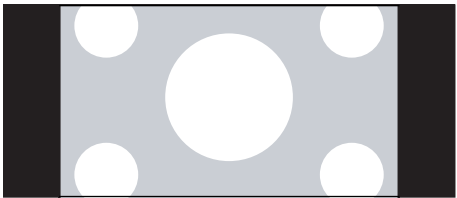
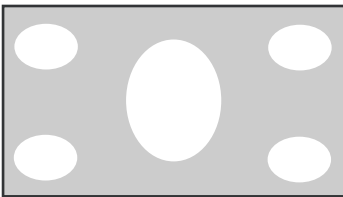
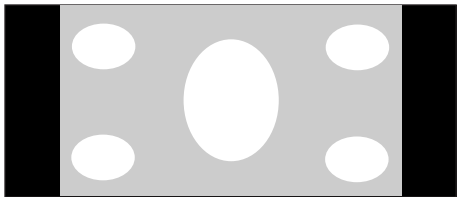
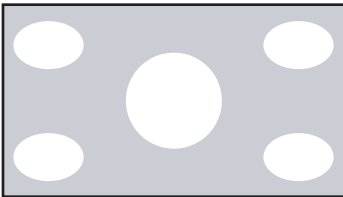
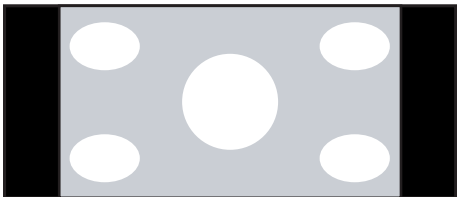
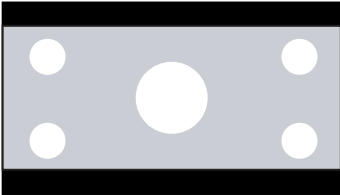
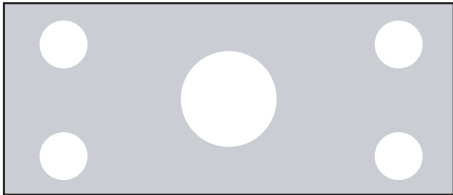
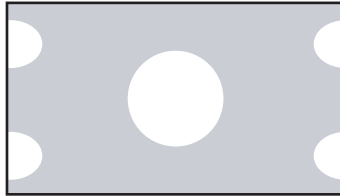
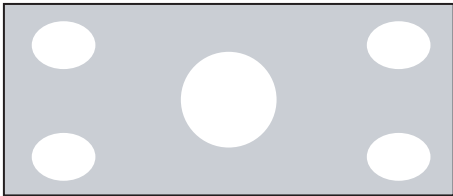

Note When you change a setting in the Installation menu, the change takes effect immediately; you do not need to press **ENTER** afterwards. (Press **EXIT** to return to the previous menu or **MENU** to exit.)

Language: Select Language from the Installation menu and press **ENTER**. Then, use the ▲ or ▼ button to select from the available languages: English, French, Spanish, German and Italian.

Orientation: Select Orientation from the Installation menu and press **ENTER**. Then, use the ▲ or ▼ button to change the orientation of the projected image. The Vision 15 can be installed on a ceiling or in a rear-screen configuration with one or more mirrors. There are four settings: Floor Front, Ceiling Front, Floor Rear and Ceiling Rear.

Keystone: Projector placement and other factors can cause geometric distortion in the projected image. To correct this, select Keystone from the Installation menu. This sub-menu provides the following options:

- **V. Keystone/H. Keystone:** To correct distortion resulting from the angle of projection, select V. Keystone or H. Keystone from the Keystone menu and use the ◀ or ▶ button to make the image rectangular. See Figure 4-6.

◀ **Installation**

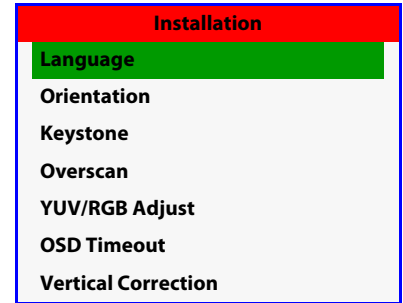

Tip Vidikron recommends that the keystone feature not be used unless absolutely necessary, as it may cause artifacts in the image.



1. The Vision 15 keystone correction can compensate for up to approximately 15 degrees of screen and/or projector tilt.
2. Straight lines or the edges of images may appear jagged while adjusting the image.

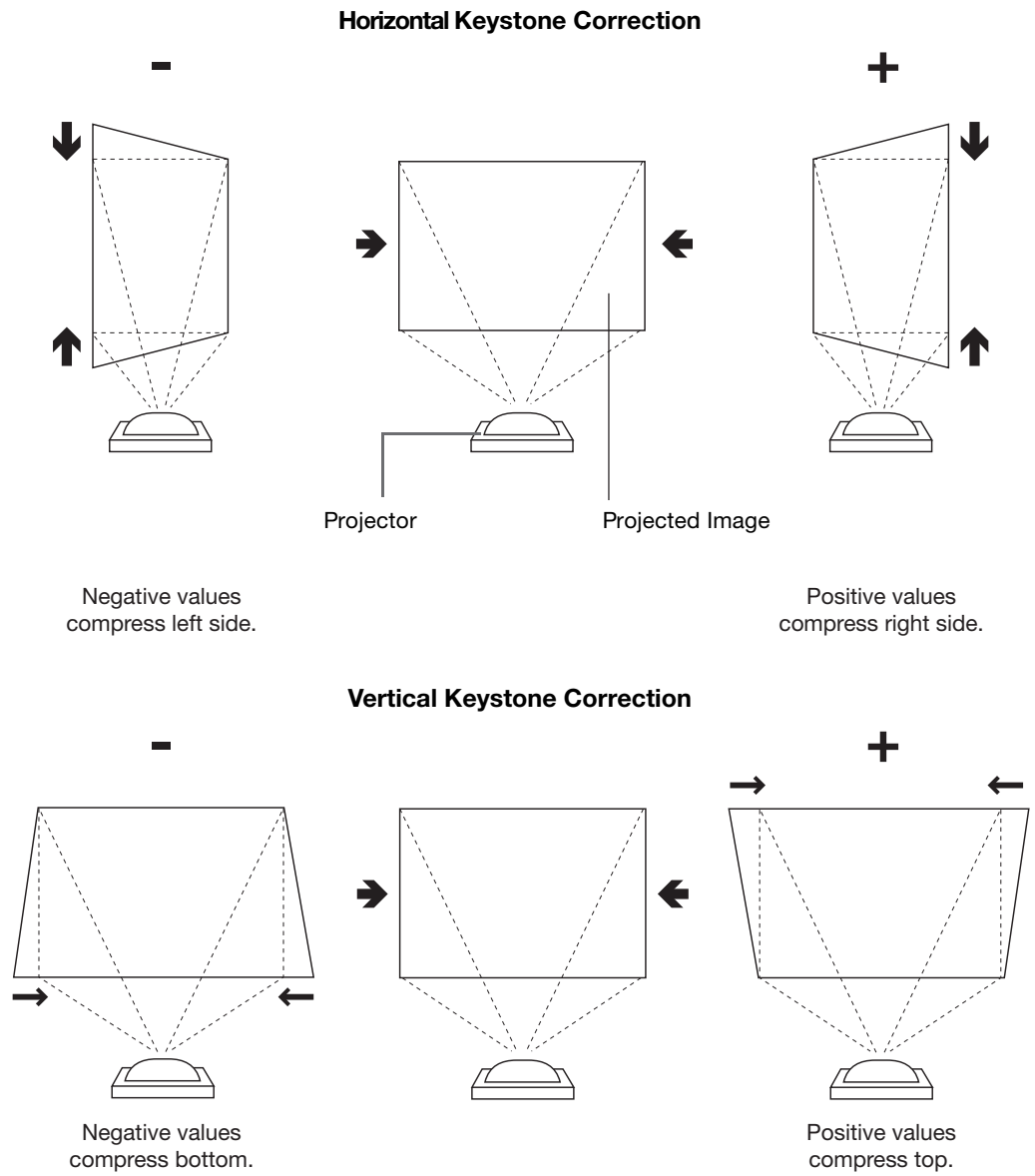

Figure 4-6. Keystone Correction

Overscan: Some SDTV/EDTV programs are produced based on the assumption that older television sets may not display the outer edges of the broadcast picture area. Overscan effectively hides these inactive, outer edges of the image. (For HDTV, DVDs and other video sources, overscan is generally not necessary or desirable.)

Overscan Type	Crop
Overscan Adjust	0

- **Overscan Type:** There are two overscan types:
 - **Crop** adds a mask at the top, bottom, left and right edges.
 - **Zoom** adds a factor to the scaling of the source image. Anything outside of the original image area is removed.
- **Overscan Adjust:** This control defines the amount of overscan applied to the image. The range is from 0 to 5.
 - In **Crop** mode, each increment adds a mask at the left and right edges of the source image equal to 1% of the displayed horizontal resolution (2% total), and at the top and bottom edges equal to 1% of the displayed vertical resolution (2% total). A setting of 5, for example, crops the image 5% on all sides or 10% total.
 - In **Zoom** mode, each increment adds a factor to the scaling of the source image so that the vertical and horizontal resolutions are 100% plus 2% increments of the size determined by the aspect ratio function. A setting of 5, for example, zooms in on the image 5% on all sides or 10% total.

Figure 4-7 illustrates the effect of each overscan setting.

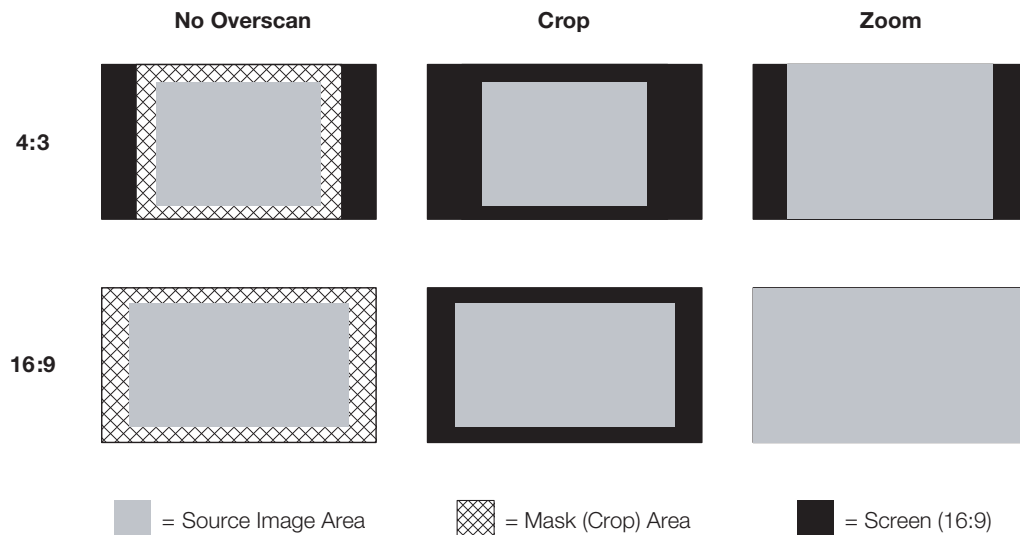

Figure 4-7. Overscan Examples

YUV/RGB Adjust: Use the settings in the YUV/RGB Adjust menu to fine-tune 480p and higher-resolution signals for optimum picture quality.

- **H. Position:** Use the up- or down-arrow buttons (▲, ▼) to select H. Position. Then, use the right-arrow button (▶) to shift the image to the right; use the left-arrow button (◀) to shift the image to the left.
- **V. Position:** Use the up- or down-arrow buttons (▲, ▼) to select V. Position. Then, use the right-arrow button (▶) to shift the image up; use the left-arrow button (◀) to shift the image down.
- **Clock:** If you notice flickering or vertical noise when displaying computer images, adjust the Clock setting to correct the issue.

- **Phase:** Adjust the phase if the image (usually from an RGB source) shows shimmer or “noise.” Pixel phase adjusts the phase of the pixel sampling clock relative to the incoming signal. The effect of this control is similar to that of a tracking control on a VCR.

For best results, use a good test pattern such as a smooth gray consisting of a clear pattern of black and white pixels, or a similar “half on, half off” graphic image. (You may find that you can stabilize the image at more than one point. Use either setting in this case.)

- **Reset:** Select Reset from the YUV/RGB Adjust menu to restore the position, clock and phase settings to their factory-default values.

OSD Timeout: This timer controls how long the menus remain on-screen after selecting them. Select a time-out period of 0, 5, 15 or 60 seconds. When you set the OSD Timeout to 0, the menus remain on-screen until you hide them by pressing **MENU**.

Vertical Correction (Vision 15ET/CineWide only): To achieve the proper image geometry with the secondary anamorphic lens, select Vertical Correction from the Installation menu. Then, use the ◀ or ▶ button to change the native aspect ratio of the display, in small increments.

The range is from 0 through 5 in increments of 1. Each increment reduces the image height by one percent. A value of 5, for example, reduces the image height by 5 percent.

Information ➤

Select Information from the Main Menu to see projector status information: the currently-active source, input signal resolution, aspect ratio, picture memory and lamp usage. This menu also displays the projector serial number.

Information	
Source	HDMI
Resolution	720x480
H. Frequency	15.7 KHZ
V. Frequency	59.8 HZ
Aspect Ratio	16:9
Picture Memory	ISF Night
Lamp Hours	450
Firmware	0014.006
Serial	VIP015VM0803001

Should you ever need to contact Vidikron Technical Support, this information will help them answer your questions or resolve product performance issues.

To adjust the lamp and perform other common, installation-related tasks, use the up- or down-arrow buttons to highlight Setup in the Main Menu and press **ENTER**.

Lamp Power: Select Lamp Power from the Setup Menu to adjust the lamp output level. You can choose to run the lamp as bright as possible (230W; this is the default setting) or you can choose the lower (180W) setting. Generally, lower lamp output prolongs the life of the lamp, but decreases brightness.

Lamp Reset: When you replace the projector lamp (refer to **Lamp Replacement** on page 56), you should also reset the lamp timer. To do this, select Lamp Reset from the Setup menu. The Vision 15 shows the number of hours the projector lamp has been in service and asks you to confirm or cancel the reset. Press **ENTER** to confirm or **EXIT** to cancel.

◀ **Setup**

Setup	
Lamp Power	230 W
Lamp Reset	
Sync Threshold	1
Source Select	Manual
Film Mode	Auto
DNR	0
Background Color	Black
12V Trigger	Normal
Factory Reset	



Note

Reset the Lamp Timer ONLY after you replace the lamp. Otherwise, the reported "Lamp Hours" will be inaccurate.



WARNING

Do not exceed the recommended lamp life of 2000 hours. An old lamp becomes increasingly fragile and prone to sudden failure.

Sync Threshold: The projector is compatible with EDTV (480p and 576p) and HDTV (720p, 1080i and 1080p) video signals. If a DVD player or other source component is not syncing properly with the projector due to non-standard sync levels, adjust this setting to correct the issue. This setting is only available for component video sources.

Source Select: The Vision 15 can automatically detect an incoming signal and switch to that input if the current source signal becomes unavailable. To enable automatic source detection, choose Source Select from the Setup menu and set it to **Auto**.

Film Mode: Use the Film Mode control to smooth out moving images from interlaced sources. In most cases, the Vision 15 detects the proper "pull-down" rate and vertical frequency.

- Choose **Auto** to allow the deinterlacer to automatically determine the proper deinterlacer mode for best display.
- Choose **Off** to force the deinterlacer to ignore film cadence and remain in video mode. Use this setting if "combing" is present or if the deinterlacer switches between modes constantly due to improper detection of film content (which can occur in animation, for instance).

Digital Noise Reduction (DNR): Select DNR from the Setup menu, then use the ◀ or ▶ button to adjust the amount of adaptive noise reduction. DNR is useful for clearing up noisy images from interlaced SD sources. Adjust as desired, keeping in mind that reducing noise (which reduces high frequencies) may also soften the image.

Background Color: Press the ◀ or ▶ button to select the image Background Color (black or blue). The Background Color appears when no incoming signal is present.

12V Trigger: Select 12V Trigger from the Setup menu to configure the 12-volt trigger output.

- Set the 12V Trigger to **Normal** if you want the trigger to activate when the projector is turned on (for instance, if the trigger is controlling a retractable screen).
- Set the 12V Trigger to **Cinema** if you want the trigger to activate when the Cinema or IntelliWide 2.35 aspect ratio is selected.

Factory Reset: To restore all Setup Menu options to their factory-default values, select Factory Reset and press **ENTER**. Use the arrow buttons to highlight "OK," then press **ENTER** again to confirm the operation.

ISF ➤ To access the ISF calibration menu, select ISF from the Main Menu and press **ENTER**.

ISF	
Picture Memory	Custom
Brightness	0
Contrast	0
Color	0
Tint	0
Sharpness	3
Gamma	2.2
Color Temp.	6500
BrilliantColor™	Off
Black Level	0 IRE
White Balance	
DNR	0
Save Settings	
Blue Image	Off
Splash Screen Timer	5
Reset to Defaults	



Note

This menu should be used by ISF-certified technicians only. You must enter a passcode to access this menu.

Picture Memory: Refer to **Picture Memory** on page 37.

Brightness: Refer to **Brightness** on page 38.

Contrast: Refer to **Contrast** on page 38.

Color: Refer to **Color** on page 39.

Tint: Refer to **Tint** on page 40.

Sharpness: Refer to **Sharpness** on page 40.

Gamma: Refer to **Gamma** on page 40.

Color Temp.: Refer to **Color Temp.** on page 40.

BrilliantColor™: Refer to **BrilliantColor™** on page 41.

Black Level: Refer to **Black Level** on page 41.

White Balance: To remove any trace of color from the white areas of the projected image, select White Balance from the ISF menu and press **ENTER**.

- **Gain:** Use the Gain controls to correct color imbalances in the bright areas of the image. A good way to do this is to use a test pattern consisting mostly of solid white areas, such as an 80 IRE "window" pattern. If the white areas contain traces of red, green or blue, decrease the Gain for that color.
- **Offset:** Use the Offset controls in the White Balance sub-menu to correct color imbalances in the dark areas of the image. A good way to do this is to use a test pattern consisting mostly of dark gray areas, such as a 30 IRE "window" pattern. If the gray areas contain traces of red, green or blue, decrease the Offset for that color.

The Gain controls increase or decrease the full-scale input range; the Offset controls shift the entire range, resulting in a change in brightness.



Note

Generally, higher Gain settings reduce the image contrast; higher Offset settings reduce the image brightness.

DNR: Refer to **Digital Noise Reduction (DNR)** on page 49.

Save Settings: To store changes to picture quality settings for the current input and resolution in the "Custom," "ISF Day" or "ISF Night" Picture Memory, choose Save Settings from the Picture Adjust menu and select "Custom," "ISF Day" or "ISF Night." To recall this preset at a later time, select it from the Picture Memory menu (see page 37) or press the corresponding button on the remote control (see Figure 2-3).

For more information about this command, refer to **Save Settings** on page 41.

Blue Image: This feature, when enabled, removes all red and green color information from the image (simulating a blue filter), and is useful for color-calibrating the projector or other video components.

Splash Screen Timer: This timer controls how long the start-up (ISF and Vidikron logo) image stays on-screen after you turn on the projector. The choices are 0, 5, 15 or 60 seconds. To disable the splash screen, set the Splash Screen Timer to 0.

Reset to Defaults: Refer to **Reset to Defaults** on page 41.

Notes:

Maintenance and Troubleshooting

- Unplug the power cord before cleaning the projector.
- Avoid using benzene or thinner, as these can damage the finish on the projector exterior.
- Do not use volatile agents, such as insecticides, on the projector.
- Do not leave rubber or plastic objects in contact with the projector for long periods as they may damage the finish of the projector.
- Wipe off dirt gently with a soft flannel cloth.
- For hard-to-remove dirt, soak a cloth in a neutral detergent diluted with water, wring the cloth well and then wipe the projector.
- Strong cleaning detergents may discolor, warp or damage the coating on the projector. Make sure to test on a small, inconspicuous area on the projector before using.

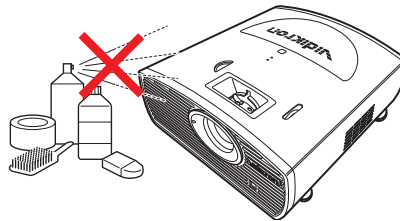

5.1 Cleaning the Projector

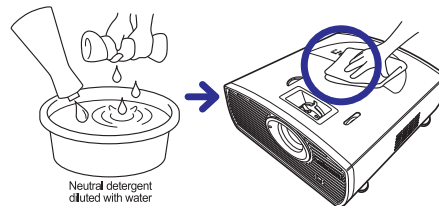

- Use a commercially available blower or lens cleaning paper (for glasses and camera lenses) for cleaning the lens. Do not use any liquid cleaning agents, as they may wear the coating film on the surface of the lens.
- The surface of the lens is easily damaged. Do not scrape or hit the lens.

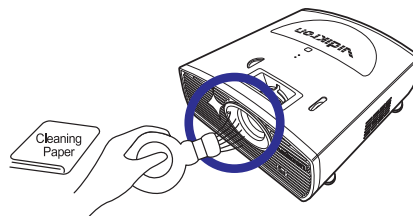

5.2 Cleaning the Lens

5.3 Cleaning the Intake and Exhaust Vents

This Vision 15 is equipped with intake and exhaust vents to allow the flow of cool air through the projector and maintain the proper operating temperature.

You should periodically clean the vents by vacuuming them with a vacuum cleaner. Vidikron recommends doing this after every 100 hours of use, or more often if the projector is used in a dirty or smoky location.

To clean the intake and exhaust vents:

1. Press **OFF** on the remote control to turn off the power. Wait until the cooling fan stops.
2. Unplug the power cord.
3. Remove dust by placing the cleaner hose on the intake and exhaust vents.

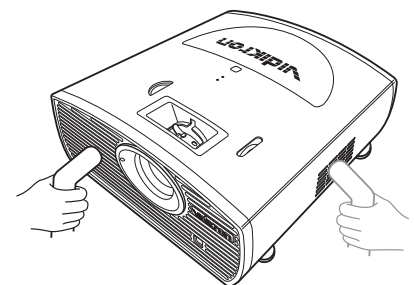
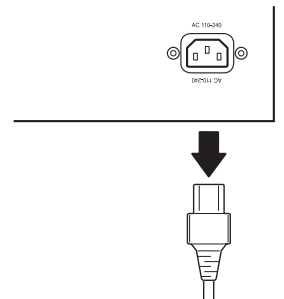
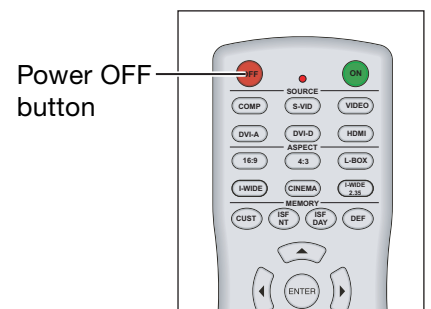
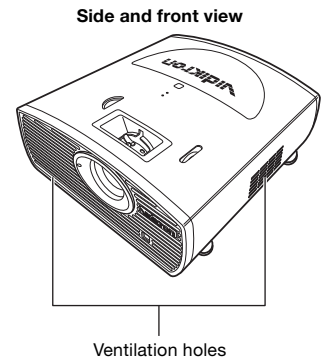

The projector lamp has a life of 2,000 hours. Maintain proper ventilation to keep the lamp operating throughout its lifetime. Do not subject the projector to unnecessary vibration.

- Lamp replacement is recommended after approximately 2,000 cumulative hours of use or when you notice a significant deterioration in the picture and color quality. To find out how long the currently-installed lamp has been in service, select Information from the Main menu.
- The actual lamp service life may be less than 2,000 hours depending on the environment in which the projector is used.
- **For lamp replacement, please contact your nearest Vidikron authorized service center or Vidikron dealer. Do not attempt to replace the lamp yourself!**



Caution

This projector uses a pressurized mercury lamp. A loud sound may indicate lamp failure. Lamp failure is caused by excessive shock, improper cooling, surface scratches or deterioration of the lamp due to usage. The period of time up to failure largely varies depending on the individual lamp and the condition and the frequency of use. It is important to note that failure can often result in the bulb cracking.

When the lamp replacement indicator and on-screen display icon are illuminated or are flashing, replace the lamp with a new one immediately, even if the lamp appears to be operating normally.

If the lamp breaks, glass particles may spread inside the lamp cage or gas contained in the lamp may be vented into the room from the exhaust vent. As the gas in this lamp contains mercury, ventilate the room well if the lamp breaks and avoid all exposure to the released gas. In case of exposure to the gas, consult a doctor as soon as possible.

If the lamp breaks, there is also a possibility that glass particles may spread inside the projector. If this happens, contact your nearest Authorized Dealer to remove the damaged lamp and ensure safe operation.

Do not remove the lamp unit immediately after turning off the projector. Touching a hot lamp can cause burns or injury. Wait at least one hour after the disconnecting the power cord to allow the surface of the lamp unit to fully cool before removing.

5.4 Lamp Maintenance

5.5 Lamp Cautions

5.6 Lamp Replacement

1. Turn off the projector and wait for the cooling fan to stop.
2. Unplug the power cord. Allow the projector to cool down for approximately one hour prior to removing the lamp assembly for replacement.
3. Loosen the two captive lamp cover screws and remove the cover.

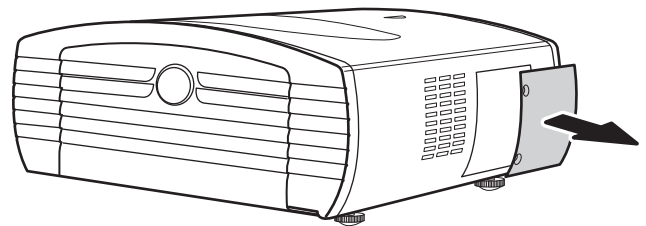
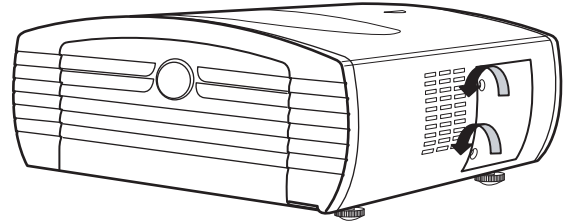

4. Loosen the four lamp assembly mounting screws.
5. Grasp the lamp assembly handle and pull gently, removing the lamp module from the projector housing. As you do so, the lamp cooling interlock switch on the inside of the lamp cavity (near the top) moves to the OFF position.

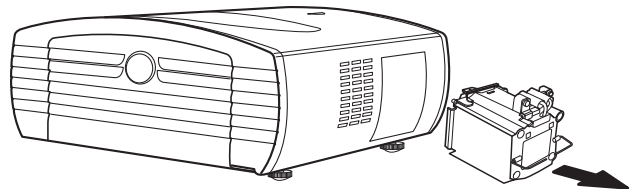

6. Gently slide the new lamp assembly into the lamp cavity. Align the two power connectors at the top of the lamp assembly with the two sockets at the top of the lamp cavity. Press gently on both sides of the lamp assembly to snap it into place. As you do so, the lamp cooling interlock switch returns to the ON position.
7. Tighten the lamp assembly mounting screws.
8. Replace the lamp cover and secure the captive lamp cover screws.
9. Plug in the projector and turn it on.
10. Reset the Lamp Timer to zero. To do this, select Lamp Reset from the Setup menu and press **ENTER**. The Vision 15 shows the number of hours the projector lamp has been in service and asks you to confirm or cancel the reset. Press **ENTER** again to confirm.

Table 5-1 provides some general guidelines for troubleshooting problems you may encounter with the Vision 15. If you encounter an issue not described here, please contact your Vidikron dealer or Vidikron Technical Support.

5.7 Troubleshooting Tips

Table 5-1. Troubleshooting Chart

Symptom	Possible Cause(s)	Solution
The projector does not turn on after initial installation.	<ul style="list-style-type: none"> The Vision 15 is not plugged in or the AC outlet is not active. The remote control batteries have run out. 	<ul style="list-style-type: none"> Ensure that the Vision 15 is plugged in and that the AC outlet is active. Replace the batteries.
The projector is on, but there is no video image on-screen.	<ul style="list-style-type: none"> Incorrect source selection. Source component is not turned on. 	<ul style="list-style-type: none"> Select the correct source. Turn on the source component.
A projected image from a DVD is split or otherwise scrambled.	<ul style="list-style-type: none"> DVD player is set to progressive scan mode. 	<ul style="list-style-type: none"> Turn off progressive scan on the DVD player. Connect the DVD player to the Component input.
Image is too bright and/or lacks definition in the bright areas of the image.	<ul style="list-style-type: none"> Contrast is set too high. 	<ul style="list-style-type: none"> Lower the contrast setting.
Image appears "washed out" and/or dark areas appear too bright.	<ul style="list-style-type: none"> Brightness is set too high. 	<ul style="list-style-type: none"> Lower the brightness setting.
Colors in the image are swapped; for example, reds appear blue or vice versa.	<ul style="list-style-type: none"> The Red/Pr, Green/Y or Blue/Pb outputs from the source are connected to the wrong inputs on the Vision 15. 	<ul style="list-style-type: none"> Ensure that the source outputs are connected to the correct Vision 15 input.
RGB-HD images appear "noisy."	<ul style="list-style-type: none"> Clock and Phase settings need adjustment. 	<ul style="list-style-type: none"> Manually adjust Clock and Phase settings (refer to YUV/RGB Adjust on page 47).
The projector will not turn back on after it was powered down, or the image disappears during operation.	<ul style="list-style-type: none"> The projector will not turn on for two minutes after power-down, to protect the lamp. The lamp has failed or was improperly installed. 	<ul style="list-style-type: none"> Wait until the cooling fan stops. Replace or re-install the lamp.

Notes:

Serial Communications

To interface the Vision 15 with a home theater automation/control system or a PC running terminal emulation software, connect it to your control system or PC as shown in Figure 3-13.

Configure the RS-232 controller or PC serial port as follows: no parity, 8 data bits, 1 stop bit and no flow control. Set the baud rate to 9600, to match that of the Vision 15 RS-232 port.

Table 6-1 lists the RS-232 command set. All commands are in ASCII format and must be in UPPERCASE.

When you send a valid command, the Vision 15 executes it and acknowledges it with the first three characters of the command followed by "OK;" for example, "RRAOK." When you send an invalid command, the Vision 15 ignores it and returns the first three characters of the command followed by "NG;" for example, "RRXNG."

Table 6-1. Serial Commands

Command	Description	Reply
RRA00	Saves current settings to the CUSTOM memory (Note 1)	RRAOK
RRA01	Saves current settings to the ISF Day memory (Note 1)	RRAOK
RRA02	Saves current settings to the ISF Night memory (Note 1)	RRAOK
RRB00	Recalls the Custom memory settings	RRBOK
RRB01	Recalls the ISF Day memory settings	RRBOK
RRB02	Recalls the ISF Night settings	RRBOK
RRC00	Selects the S-VIDEO input	RRCOK
RRC01	Selects the COMPOSITE VIDEO input	RRCOK
RRC02	Selects the COMPONENT input	RRCOK
RRC03	Selects the DVI-D input	RRCOK
RRC04	Selects the HDMI input	RRCOK
RRC05	Selects the DVI-A input	RRCOK
RRD00	Selects the 16:9 aspect ratio	RRDOK
RRD01	Selects the 4:3 aspect ratio	RRDOK

Notes:

1. All image quality settings must be made with the remote control. After the image adjustments are complete, you can use these commands to store the settings in the selected memory.
2. The power on command (PON) will not provide an OK reply; it will instead reply with a random character. For your automation system, simply ensure that you receive a character after the PON command. If you do not get any reply after PON, send PON again.

6.1 RS-232 Connection and Port Configuration

6.2 Serial Command Syntax

Table 6-1. Serial Commands (continued)

Command	Description	Reply
RRD02	Selects the LETTERBOX aspect ratio	RRDOK
RRD03	Selects the INTELLIWIDE aspect ratio	RRDOK
RRD04	Selects the CINEMA (2.35:1) aspect ratio	RRDOK
RRD05	Selects the INTELLIWIDE 2.35 aspect ratio	RRDOK
RRE00	Turns the projector OFF	RREOK
PON	Turns the projector ON	Random (Note 2)
RRF00	Selects the UP button on the remote control	RRFOK
RRF01	Selects the DOWN button on the remote control	RRFOK
RRF02	Selects the LEFT button on the remote control	RRFOK
RRF03	Selects the RIGHT button on the remote control	RRFOK
RRF04	Selects the ENTER button on the remote control	RRFOK
RRG00	Selects the MENU button on the remote control	RRGOK
RRG01	Selects the EXIT button on the remote control	RRGOK

Notes:

1. All image quality settings must be made with the remote control. After the image adjustments are complete, you can use these commands to store the settings in the selected memory.
2. The power on command (PON) will not provide an OK reply; it will instead reply with a random character. For your automation system, simply ensure that you receive a character after the PON command. If you do not get any reply after PON, send PON again.

Specifications

Table 7-1 lists the Vision 15 specifications.

7.1 Vision 15 Specifications

Table 7-1. Vision 15 Specifications

Projector Type:	Digital Light Processing (DLP), Single-Chip DMD
Native Resolution:	1280 x 720 (16:9)
Aspect Ratios:	4:3, Letterbox, 16:9, IntelliWide, Cinema, IntelliWide 2.35
Video Standards:	NTSC, PAL, SECAM
Video Compatibility:	480i, 480p, 576i, 576p, 720p, 1080i, 1080p
Scan Frequency:	Horizontal: 15 - 91 kHz Vertical: 24 - 85 Hz
Picture Size (16:9 Screen):	Recommended Width: 72 in. (1.83 m) to 120 in. (3.05 m)
Throw Distance (Factor x Screen Width):	Refer to Table 3-3
Horizontal and Vertical Offset (when projector is inverted):	Refer to Table 3-4
Lamp:	230 Watts
Estimated Lamp Life:	2000 hours
Video Inputs:	(1) Composite (1) S-Video (1) RCA Component (YPbPr) (1) DVI-I (1) HDMI with HDCP
Control Options:	- Discrete IR remote - Serial commands via RS-232
RS-232 Communication Parameters:	9600 bps, no parity, 8 data bits, 1 stop bit, no flow control
+12V Output:	Max. 0.25 Amps, active when Cinema or IntelliWide 2.35 Aspect Ratio is selected (Vision 15ET/CineWide only) or when projector is turned on; Tip = +12V; Sleeve = Ground
Power Requirements:	100 to 240 VAC (auto-sensing), 50/60 Hz, 330 Watts (1126.3 BTUs/hour)
Operating Environment:	41°F to 95°F (5°C to 35°C), 0% to 90% humidity (non-condensing)
Dimensions:	Vision 15: See Figure 7-1 Vision 15ET: See Figure 7-2
Weight (including lens):	Vision 15: 30.1 lbs. (13.65 kg) Vision 15ET: 30.8 lbs. (13.97 kg)

Table 7-1. Vision 15 Specifications (continued)

Regulatory Approvals:

Complies with FCC Class B, CE, C-Tick, GOST

Limited Warranty:

Projector: Two (2) years parts and labor from the date of delivery to the end user.

Lamp: 1000 hours or six (6) months, whichever comes first.

Specifications are subject to change without notice.

Figure 7-1 shows the Vision 15 dimensions.

7.2 Vision 15 Dimensions

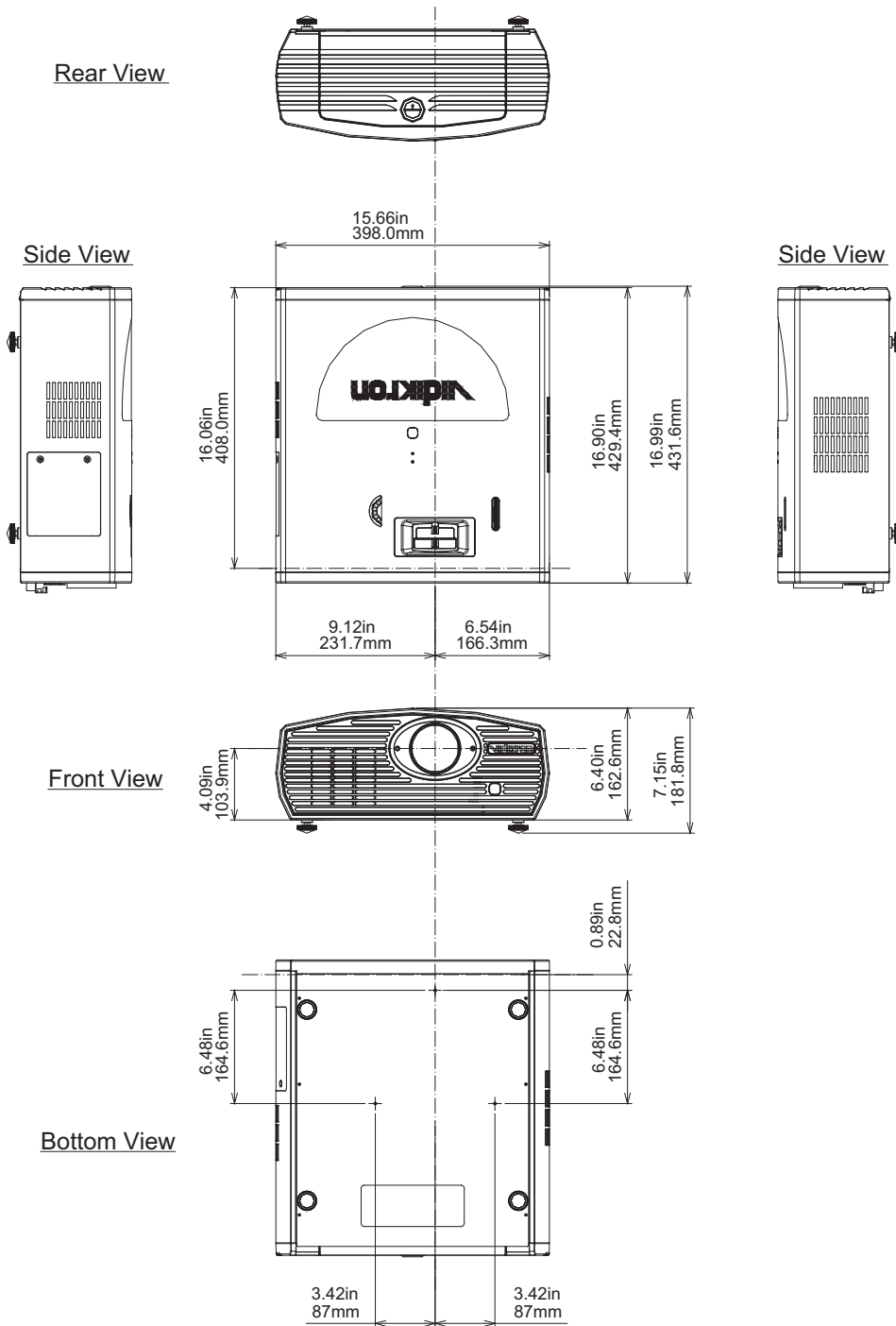

Figure 7-1. Vision 15 Dimensions

7.3 Vision 15ET Dimensions

Figure 7-2 shows the Vision 15ET dimensions.

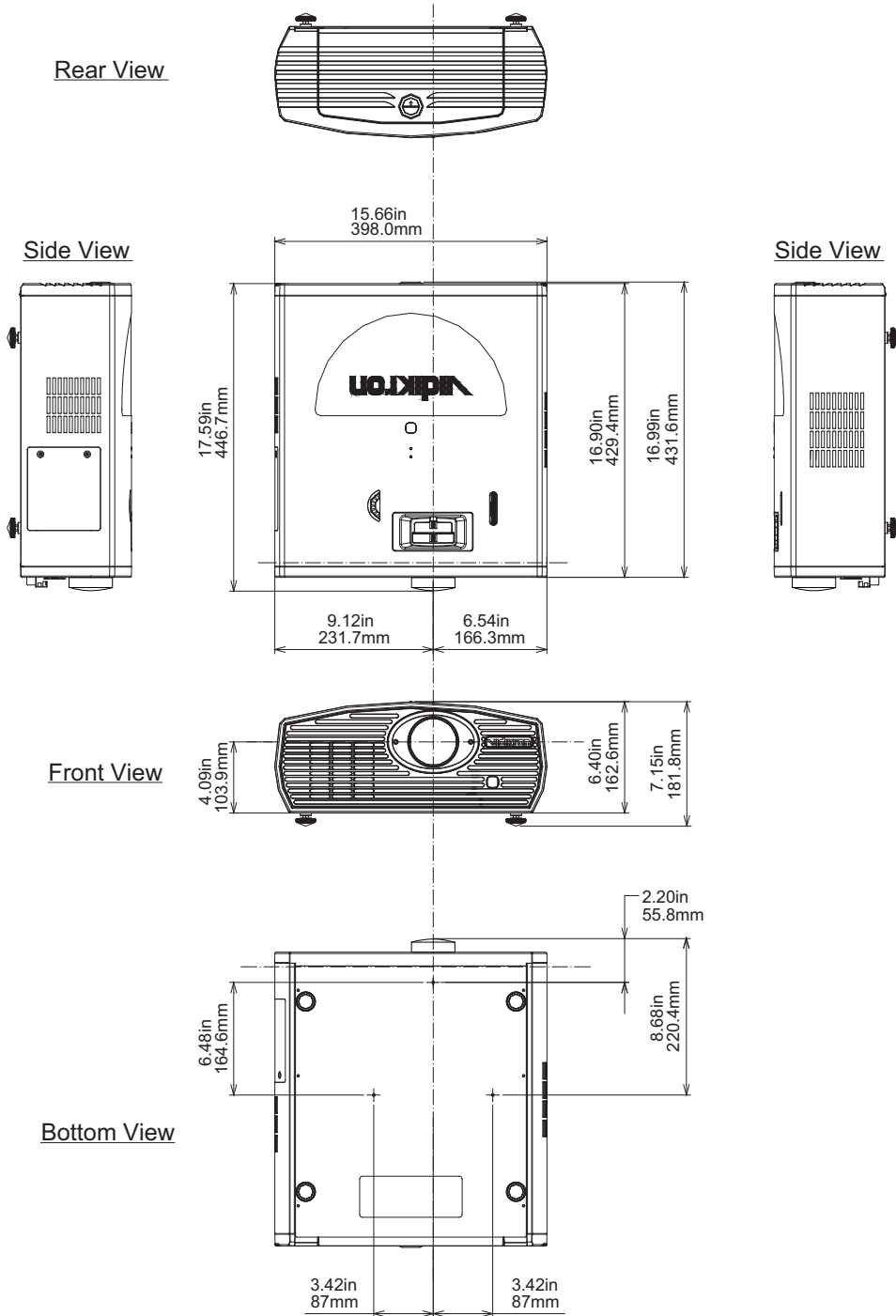

Figure 7-2. Vision 15ET Dimensions

The Vision 15 can display video signals from a variety of computer sources via its DVI-I and HDMI inputs.

Table 7-2 lists the signal types that are compatible with the Vision 15, and indicates which of those are VESA standards.

7.4 Computer Signal Compatibility

Table 7-2. Computer Signal Compatibility Chart

PC/MAC/ WS	Resolution		Horizontal Frequency (kHz)	Vertical Frequency (Hz)	VESA Standard	HDMI Support
PC	VGA	720 x 400	31.5	70		√
		640 x 480	31.5	60		√
			37.9	72	√	√
			37.5	75	√	√
			43.3	85	√	√
	SVGA	800 x 600	35.1	56	√	√
			37.9	60	√	√
			48.1	72	√	√
			46.9	75	√	√
			53.7	85	√	√
	XGA	1024 x 768	48.4	60	√	√
			56.5	70	√	√
			60.0	75	√	√
			68.7	85	√	√
	WXGA	1280 x 768	47.8	60		√
	SXGA	1280 x 1024	64.0	60	√	√
			80.0	75	√	√
			91.1	85	√	√
	WSXGA+	1680 x 1050	65.2	60		√
	UXGA	1680 x 1200	75.0	60	√	√
MAC 13"	VGA	640 x 480	34.9	67		√
MAC 16"	SVGA	832 x 624	49.6	75		√
MAC 19"	XGA	1024 x 768	60.2	75		√

Notes:

1. This projector may not be able to display images from notebook computers in simultaneous (CRT/LCD) mode. Should this occur, switch the notebook computer to "CRT only" mode. If you are unsure how to do this, refer to your notebook computer's user manual.
2. Interlaced video signals received through the DVI-I input may not display correctly. If this occurs, use the Component, S-video or Composite video input instead.
3. The Vision 15 does not support composite sync or sync-on-green RGB signals.

7.5 Video Signal Compatibility

Table 7-3 lists numerous common video signal formats and indicates which input(s) on the Vision 15 can accept a given format.

Table 7-3. Video Signal Compatibility Chart

Resolution			H-Freq (kHz)	V-Freq (Hz)	Compatible Inputs (Note 1)					
					Comp.	S-Video	Composite	DVI-A	DVI-D	HDMI
SD Video	NTSC	640 x 480i	15.73	59.94/60	√	√	√	√	√	√
	PAL	768 x 576i	15.63	50	√	√	√	√	√	√
	SECAM				√	√	√	√	√	√
	NTSC-4.43		15.73	59.94/60	(adjustment required)					
	PAL-M		15.73/15.75	59.94/60						
	PAL-N		15.63	50						
	NTSC-J		15.73	59.94/60						
	PAL-60		15.73/15.75	59.94/60						
NTSC-50	(not supported)									
EDTV	480p	720 x 480p	31.5	59.94/60	√			√	√	√
	576p	720 x 576p	31.3	50	√			√	√	√
HDTV	1080i/50	1920 x 1080i	28.1	50	√			√	√	√
	1080i/60		33.8	59.94/60	√			√	√	√
	720p/50	1280 x 720p	37.5	50	√			√	√	√
	720p/60		45.0	59.94/60	√			√	√	√
	1080p/24		26.98/27	23.98/24	√			√	√	√
	1080p/50	1920 x 1080p	56.25	50	√			√	√	√
	1080p/60		67.4/67.5	59.94/60	√			√	√	√

Notes: The Component input accepts both analog (YPbPr) and digital (YCbCr) signals.

020-0863-00 Rev. A
January 2008



1-888-4-VIDIKRON
Fax 503-748-8161
www.vidikron.com



SERIAL NUMBER

Free Manuals Download Website

<http://myh66.com>

<http://usermanuals.us>

<http://www.somanuals.com>

<http://www.4manuals.cc>

<http://www.manual-lib.com>

<http://www.404manual.com>

<http://www.luxmanual.com>

<http://aubethermostatmanual.com>

Golf course search by state

<http://golfingnear.com>

Email search by domain

<http://emailbydomain.com>

Auto manuals search

<http://auto.somanuals.com>

TV manuals search

<http://tv.somanuals.com>