

VISION

VISION 50
MODEL

SERIES DLP™ PROJECTORS

Vision 50

Vision 50/CineWide™

Vision 50/CineWide with AutoScope™

TWO YEAR LIMITED WARRANTY

For Projectors, Video Processors and Controllers

Congratulations on your purchase of a Vidikron video product and welcome to the Vidikron family! With proper installation, setup and care, you should enjoy many years of unparalleled video performance.

This is a LIMITED WARRANTY as defined in the Magnuson-Moss Warranty Act. Please read it carefully and retain it with your other important documents.

WHAT IS COVERED UNDER THE TERMS OF THIS LIMITED WARRANTY:

SERVICE LABOR: Vidikron will pay for service labor by Vidikron Authorized Service Center when needed as a result of manufacturing defect for a period of two (2) years from the effective date of delivery to the end user (excluding the lamp).

PARTS (not including the lamp): Vidikron will provide new or rebuilt replacement parts for the parts that fail due to defects in materials or workmanship for a period of two (2) years from the effective date of delivery to the end user. Such replacement parts are then subsequently warranted for the remaining portion (if any) of the original warranty period.

PROJECTOR LAMP: Vidikron will pay for service labor by a Vidikron Authorized Service Center when needed as a result of a manufacturing defect for a period of six (6) months or 1000 hours, whichever comes first, from the effective date of delivery to the end user. In addition, Vidikron will provide a new or rebuilt replacement lamp for the lamp that fails due to defects in materials or workmanship for a period of six (6) months or 1000 hours, whichever comes first, from the effective date of delivery to the end user. Such replacement lamps are then subsequently warranted for the remaining portion (if any) of the original warranty period.

WHAT IS NOT COVERED UNDER THE TERMS OF THIS LIMITED WARRANTY:

This Limited Warranty only covers failure due to defects in materials and workmanship that occur during normal use and does not cover normal maintenance. This Limited Warranty does not cover cabinets or any appearance items; failure resulting from accident, misuse, abuse, neglect, mishandling, misapplication, faulty or improper installation or setup adjustments; improper maintenance, alteration, improper use of any input signal; damage due to lightning or power line surges, spikes and brownouts; damage that occurs during shipping or transit; or damage that is attributed to acts of God. In the case of remote control units, damage resulting from leaking, old, damaged or improper batteries is also excluded from coverage under this Limited Warranty.

CAUTION: THIS LIMITED WARRANTY ONLY COVERS VIDIKRON PRODUCTS PURCHASED FROM VIDIKRON AUTHORIZED DEALERS. ALL OTHER PRODUCTS ARE SPECIFICALLY EXCLUDED FROM COVERAGE UNDER THIS WARRANTY. MOREOVER, DAMAGE RESULTING DIRECTLY OR INDIRECTLY FROM IMPROPER INSTALLATION OR SETUP IS SPECIFICALLY EXCLUDED FROM COVERAGE UNDER THIS LIMITED WARRANTY. IT IS IMPERATIVE THAT INSTALLATION AND SETUP WORK BE PERFORMED ONLY BY AN AUTHORIZED VIDIKRON DEALER TO PROTECT YOUR RIGHTS UNDER THIS WARRANTY. THIS WILL ALSO ENSURE THAT YOU ENJOY THE FINE PERFORMANCE OF WHICH YOUR VIDIKRON PRODUCT IS CAPABLE WHEN INSTALLED AND CALIBRATED BY VIDIKRON AUTHORIZED PERSONNEL.

RIGHTS, LIMITS AND EXCLUSIONS:

Vidikron limits its obligations under any implied warranties under state laws to a period not to exceed the warranty period. There are no express warranties. Vidikron also excludes any obligation on its part for incidental or consequential damages related to the failure of this product to function properly. Some states do not allow limitations on how long an implied warranty lasts, and some states do not allow the exclusion or limitation of incidental or consequential damages. So the above limitations or exclusions may not apply to you. This warranty gives you specific legal rights, and you may also have other rights that vary from state to state.

EFFECTIVE WARRANTY DATE:

This warranty begins on the effective date of delivery to the end user. For your convenience, keep the original bill of sale as evidence of the purchase date.

IMPORTANT -- WARRANTY REGISTRATION:

Please fill out and mail your warranty registration card. It is imperative that Vidikron knows how to reach you promptly if we should discover a safety problem or product update for which you must be notified.

CONTACT A VIDIKRON AUTHORIZED SERVICE CENTER TO OBTAIN SERVICE:

Repairs made under the terms of this Limited Warranty covering your Vidikron video product will be performed at the location of the product, during usual working hours, providing location of product is within normal operating distance from a Vidikron Authorized Service Center. In some instances it may be necessary for the product to be returned to the Vidikron factory for repairs. If, solely in Vidikron's judgment, location of product to be repaired is beyond normal operating distance of the closest Vidikron Authorized Service Center, or the repair requires the unit be returned to the Vidikron factory, it is the owner's responsibility to arrange for shipment of the product for repair. These arrangements must be made through the selling Vidikron Dealer. If this is not possible, contact Vidikron directly for a Return Authorization number and shipping instructions. Vidikron will return product transportation prepaid in the United States, unless no product defect is discovered. In that instance, shipping costs will be the responsibility of the owner.

COPYRIGHT AND TRADEMARKS:

© Copyright 2007 Vidikron, a Runco International Company. This document contains proprietary information protected by copyright, trademark and other intellectual property laws. All rights are reserved. No part of this manual may be reproduced by any mechanical, electronic or other means, in any form, without prior written permission of the manufacturer.

Vidikron, Vision, IntelliWide, Imagix, DView and CSMS are trademarks of Vidikron. All other trademarks and registered trademarks used in this document are the property of their respective owners.

Vidikron products are manufactured under one or more of the following patents: US. Patent 6755540 and Other Patents Pending.

ADDITIONAL INFORMATION:

To locate the name and address of the nearest Vidikron Authorized Service Center, or for additional information about this Limited Warranty, please call or write:

VIDIKRON
Attn: Customer Service Department
2900 Faber Street
Union City, CA 94587
Ph: (510) 324-5900
Fax: (510) 324-5905
Toll Free: (888) 4VIDIKRON

VIDIKRON PRODUCT INFORMATION
RETAIN THIS INFORMATION FOR YOUR RECORDS

Model Purchased

Date

Serial Number

Vidikron Authorized Dealer Name

Address

City

State/Province

Postal Code

Phone

Fax

Safety Precautions

Thank you for your purchase of this quality Vidikron video projector! It has been designed to provide you with the quality of video that is expected in a home theater. For the best performance, please read this manual carefully as it is your guide through the menus and operation.

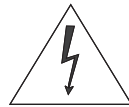
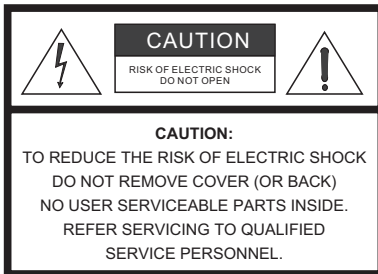

WARNING

This symbol is intended to alert the user to the presence of uninsulated “dangerous voltage” within the product’s enclosure that may be of sufficient magnitude to constitute a risk of electric shock.



This symbol is intended to alert the user to the presence of important operating and maintenance (servicing) instructions in the literature accompanying the appliance.

This equipment has been tested and found to comply with the limits for a Class B digital device, pursuant to Part 15 of the FCC Rules. These limits are designed to provide reasonable protection against harmful interference in a residential installation.

1. Read these instructions.
2. Keep these instructions.
3. Heed all warnings.
4. Do not use this equipment near water, outdoors or otherwise exposed to the elements.
5. Clean only with a dry cloth.
6. Do not block any ventilation openings.
7. Do not install near any heat sources such as radiators, heat registers, stoves, or other apparatus (including amplifiers) that produce heat.
8. Do not defeat the safety feature of the polarized or grounding type plug. A polarized type plug has two blades with one wider than the other. A grounding type plug has two blades and a third grounding prong. The third prong is provided for your safety. If the provided plug does not fit into your outlet, consult an electrician for the replacement of the obsolete outlet.
9. The 12V trigger only outputs DC 12V signal for triggering. Do not connect to any other power input or output. This could cause damage to this unit.
10. Only use accessories specified by Vidikron.
11. Keep the packing material in case the equipment should ever need to be shipped.
12. Unplug this projector during lightning storms or when it will not be used for an extended period of time.
13. The lamp becomes extremely hot during operation. Allow the projector to cool down for approximately 45 minutes prior to removing the lamp assembly for replacement. Do not operate lamps beyond the rated lamp life. Excessive operation of lamps beyond rated life could cause them to explode in rare occasions.
14. Refer all servicing to qualified service personnel. Servicing is required when the projector has been damaged in any way, objects have fallen or spilled into the projector, the projector has been exposed to rain or moisture, does not operate normally, or has been dropped.

Table of Contents

TWO YEAR LIMITED WARRANTY	iii
Safety Precautions	vi
1. Introduction	1
About This Manual	1
Target Audience.....	1
If You Have Comments About This Manual... ..	1
Textual and Graphic Conventions	1
Using This Manual	2
Description, Features and Benefits	3
Key Features and Benefits.....	4
Parts List	4
2. Controls and Functions	5
Vision 50 at a Glance	5
Vision 50 Connector Panel	7
Built-In Keypad	8
Vision 50 Remote Control	9
Remote Control/Built-In Keypad Functional Comparison	12
3. Installation	13
Remote Control	13
Notes on Batteries	13
Notes on Remote Control Operation.....	13
Quick Setup	14
Installation Considerations	15
Installation Type.....	15
Ambient Light	15
Throw Distance.....	16
Vertical and Horizontal Position	17
Vertical Lens Shift	17
Folded Optics	18
Other Considerations	18
Installing the Optional CineWide Lens Mount	19
Installing the AutoScope Lens Motor (Vision 50/CineWide with AutoScope).....	20
Installing the Fixed CineWide Base Plate (Vision 50/CineWide)	23

Mounting the Vision 50	24
Floor Mounting (Upright)	24
Ceiling Mounting (Inverted)	24
Adjusting the Projector Height or Projection Angle	24
Connections to the Vision 50	25
Connector Panel Access	25
Connecting Source Components to the Vision 50	25
RS-232 Controller Connection	29
Connecting 12-volt Trigger Output to External Theater Equipment.....	30
Connecting to AC Power.....	31
Turning on the Power	31
Changing the OSD Language	32
Adjusting the Picture Orientation	32
Primary Lens Adjustments	32
Focus	32
Zoom	32
Vertical Lens Shift	32
Installing and Adjusting the CineWide Anamorphic Lens	33
Anamorphic Lens Installation and Adjustment - Vision 50/CineWide	33
Anamorphic Lens Installation and Adjustment - Vision 50/CineWide with AutoScope	36
4. Operation	43
Selecting Video Memory	43
Selecting an Aspect Ratio	43
Selecting An Input Source	43
Using Picture-In-Picture/Picture-By-Picture (PIP/PBP)	43
Using the On-Screen Menus	44
Main Menu	46
Picture Adjust	46
Image Option	51
Projector Status	54
Installation.....	55
Service.....	56
ISF Calibration.....	60
5. Maintenance and Troubleshooting	63
Lamp Replacement	63
Troubleshooting Tips	64

6. Serial Communications	67
RS-232 Connection and Port Configuration	67
Serial Command Syntax	67
7. Specifications	71
Vision 50 Specifications	71
Vision 50 Dimensions	74
APPENDIX A. Personalizing the ISF Splash Screen on the Vision 50	A-1

Notes:

List of Figures

2-1. Vision 50 Front/Side/Top View	5
2-2. Vision 50 Rear/Bottom/Side View	6
2-3. Vision 50 Connector Panel	7
2-4. Vision 50 Remote Control	9
2-5. Remote Control/Built-In Keypad Functional Cross-Reference	12
3-1. Estimating Throw Distance	16
3-2. Projector Placement	17
3-3. Vertical Lens Shift (Example Only)	17
3-4. Folded Optics	18
3-5. Vision 50/CineWide with AutoScope Motor Assembly – Exploded View	20
3-6. Vision 50 with Ceiling Mount Adapters/Projector Stands	21
3-7. AutoScope Lens Motor Installation	22
3-8. Vision 50/CineWide with Anamorphic Lens Base Plate and Ceiling Mounting Plate - Bottom View	23
3-9. HDMI/DVI Source Connections	25
3-10. RGB Connections	26
3-11. Progressive Component Video Connections	27
3-12. Composite, S-Video and Component Video Connections	28
3-13. RS-232 Control System Connection	29
3-14. Connecting the 12-volt Trigger Output to the AutoScope Lens Motor	30
3-15. Connecting the 12-volt Trigger Output to Other Equipment	30
3-16. Standard Vision 50 Anamorphic Lens Mounting Assembly	33
3-17. Anamorphic Lens Mounting Assembly - Exploded View	36
3-18. Attaching the Anamorphic Lens to the Lens Adapter Ring	37
4-1. Vision 50 OSD Menu Structure	45
4-2. Typical PLUGE Pattern for Adjusting Brightness	47
4-3. Typical Gray Bar Pattern for Adjusting Contrast	48
4-4. Typical Color Bar Pattern for Adjusting Color Saturation and Tint	48
4-5. Typical Test Pattern for Adjusting Sharpness	50
7-1. Vision 50 Dimensions (with Optional Fixed Anamorphic Lens)	74

Notes:

Introduction

This Owner's Manual describes how to install, set up and operate the Vidikron Vision 50 Series Digital Light Processing (DLP™) Projectors. This product family consists of the Vision 50, Vision 50/CineWide™ and Vision 50/CineWide with AutoScope™ projectors.

Throughout this manual, the Vidikron Vision 50 Series DLP Projectors are referred to collectively as the "Vision 50." Except where noted, the features and functions described in this manual are common to both versions of this product.

Vidikron has prepared this manual to help home theater installers and end users get the most out of the Vision 50.

Vidikron has made every effort to ensure that this manual is accurate as of the date it was printed. However, because of ongoing product improvements and customer feedback, it may require updating from time to time. You can always find the latest version of this and other Vidikron product manuals on-line, at www.Vidikron.com.

Vidikron welcomes your comments about this manual. Send them to info@vidikron.com.

Text Conventions: The following conventions are used in this manual, in order to clarify the information and instructions provided:

- Remote and built-in keypad button identifiers are set in upper-case bold type; for example, "Press **EXIT** to return to the previous menu."
- Computer input (commands you type) and output (responses that appear on-screen) is shown in monospace (fixed-width) type; for example: "To change the aspect ratio to Letterbox, type `x063x <Enter>`."
- All keys with functional names are initial-capped, set in bold type and enclosed in angle brackets. These keys are the following: `<Enter>`, `<Spacebar>`, `<Control>`, `<Esc>` and `<Tab>`.
- `<Enter>` indicates that you may press either the RETURN or ENTER key on your keyboard if it has both keys.

In addition to these conventions, underlining, boldface and/or italics are occasionally used to highlight important information, as in this example:



*A carriage return **must** be used after each command or string.*

1.1 About This Manual

◀ **Target Audience**

◀ **If You Have Comments About This Manual...**

◀ **Textual and Graphic Conventions**

Graphic Conventions: These symbols appear in numerous places throughout the manual, to emphasize points that you must keep in mind to avoid problems with your equipment or injury:



Tip

TIPS highlight time-saving short cuts and helpful guidelines for using certain features.



Note

NOTES emphasize text with unusual importance or special significance. They also provide supplemental information.



Caution

CAUTIONS alert users that a given action or omitted action can degrade performance or cause a malfunction.



WARNING

WARNINGS appear when a given action or omitted action can result in damage to the equipment, or possible non-fatal injury to the user.



DANGER!

DANGER appears when a given action can cause severe injury or death.

1.2 Using This Manual

Use the following table to locate the specific information you need in this manual.

If you need...	... Turn to page:
Information about obtaining service	iv
General information about the Vision 50 Series DLP Projectors	3
Installation instructions	13
First-time configuration instructions	32
Advanced configuration instructions	56
Troubleshooting tips	64
Specifications for the Vision 50 Series DLP Projectors	71

The Vision 50 Series DLP Projectors offer the astounding picture quality and versatility heretofore associated with more expensive projectors. Their 1280 x 720 native resolution DLP light engine incorporates all-new technology for bright, pristine high-definition images.

Contrast ratio and dynamic range extend to new heights with Vidikron's exclusive V² Aperture Control™ (VAC), an electronically-controlled iris system.

The standard Vision 50 is equipped with a precision optics package offering a power zoom control and a throw range of 1.82:1 to 2.37:1.

The Vision 50's illumination system incorporates Vidikron's exclusive DualV Stage Illumination™ (DVSI™), which provides two light intensity levels to allow maximum flexibility for screen size, ambient light conditions, brightness and contrast balance, and lamp life preservation. It also has a newly refined cooling system, which increases efficiency and reduces noise levels.

The Vision 50 has been engineered to comply with Imaging Science Foundation™ (ISF) standards for maximum home theater image quality. Vidikron's sophisticated parameters for white balance and color gamut control have also been implemented for precise balance of gray scale and color. The Vision 50 incorporates Vidikron-proprietary de-interlacing technology that provides exceptional scaling and film-to-video (3:2 pull-down) conversion for the most artifact-free images possible.

For uncompromising widescreen reproduction of movies originally filmed in the "scope" (2.35:1) format, the Vision 50 can be equipped with Vidikron's patent-pending CineWide technology, a combination of software, electronics and high-quality anamorphic optics. CineWide maintains constant vertical height on the screen just as in a movie theater. When a viewer transitions from 1.78:1 (16:9) program material to 2.35:1, the image simply gets wider while full height is maintained. Also available with the Vision 50 is CineWide with AutoScope, an enhanced, remote-controlled version of CineWide.

**Note**

CineWide requires the use of a 2.35:1 or similar aspect ratio superwide format screen.

Discrete IR and RS-232 control make custom installation seamless, while discrete source and aspect ratio selection accommodate any automation control system.

1.3 Description, Features and Benefits

- Key Features and Benefits** ➤ The Vision 50 offers these key features and benefits:
- Native Resolution: 1280 x 720 (16:9 Native Aspect Ratio)
 - DLP system using high-performance Digital Micromirror Device (DMD)
 - 8-segment, 5x color wheel produces wide dynamic range and rich grayscale
 - V² Aperture Control (VAC) provides for infinitely variable adjustment of the light path through the optics, enabling the perfect balance of black and white levels for each individual installation
 - Picture in Picture / Picture by Picture functions allow you to display two inputs on the screen at the same time
 - HDMI Input with High-bandwidth Digital Content Protection (HDCP)
 - HDTV Compatible

- Parts List** ➤ Your Vision 50 is shipped with the following items. If any items are missing or damaged, please contact your Vidikron dealer or Vidikron Customer Service at (888) 4VIDIKRON.
- Vision 50 DLP Projector
 - Remote Control Unit and two (2), AAA-size batteries
 - AC Power Cords (North America, Europe, Asia)
 - Source Connection Cables:
 - Composite Video
 - S-Video
 - Component Video
 - RGB (DB15HD-to-5 x BNC)
 - HDMI to HDMI
 - HDMI to DVI
 - +12-volt Trigger Cable (3.5-mm, mini phono plug to two bare wires)
 - Warranty information and registration card
 - Vidikron Vision 50 Series Owner's Operating Manual (this document)

Optional Accessories:

- CineWide™ technology (fixed, secondary anamorphic lens)
- CineWide™ with AutoScope™ system (secondary anamorphic lens and motorized mount)
- Ceiling mount kit for Vision 50 or Vision 50/CineWide (part number VIHK-000425)
- Ceiling mount kit for Vision 50/CineWide with AutoScope (part number VIHK-000175)

2. Controls and Functions

Figure 2-1 and Figure 2-2 show the key Vision 50 components.

2.1 Vision 50 at a Glance

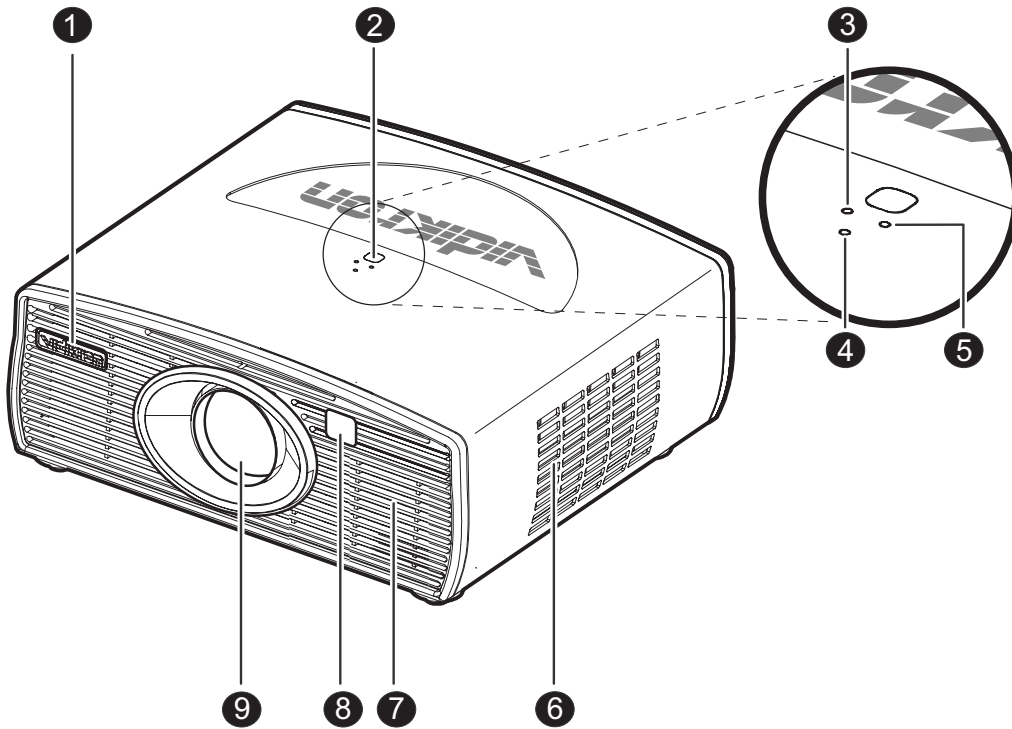
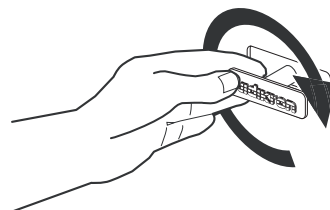

Figure 2-1. Vision 50 Front/Side/Top View

1. **VIDIKRON LOGO**

The logo can be rotated to match the projector orientation: inverted (ceiling-mounted) or upright. To rotate the logo, grip it at the sides, pull it away from the projector and rotate it 180 degrees.



2. **TOP IR SENSOR**

3. **LAMP LED**

Indicates lamp status as follows:

- Off during normal operation
- Red when the lamp has exceeded its usage life or developed a problem.
- Flashes red when the fans are not working or the lamp cover is open

4. **POWER/STANDBY LED**

Indicates power status as follows:

- Orange when the projector is in standby mode
- Flashes orange for 45 seconds after the projector is turned on to indicate that the lamp is warming up

- Green during normal operation
 - Flashes green for 110 seconds after the projector is turned off to indicate that the lamp is cooling down
5. **TEMP LED**
Indicates fan status and internal temperature as follows:
- Off during normal operation
 - Red when internal temperature is too high
 - Flashes red when the fans are not working or the lamp cover is open
6. **INTAKE VENT**
7. **EXHAUST VENT**
8. **FRONT IR SENSOR**
9. **PROJECTION LENS**

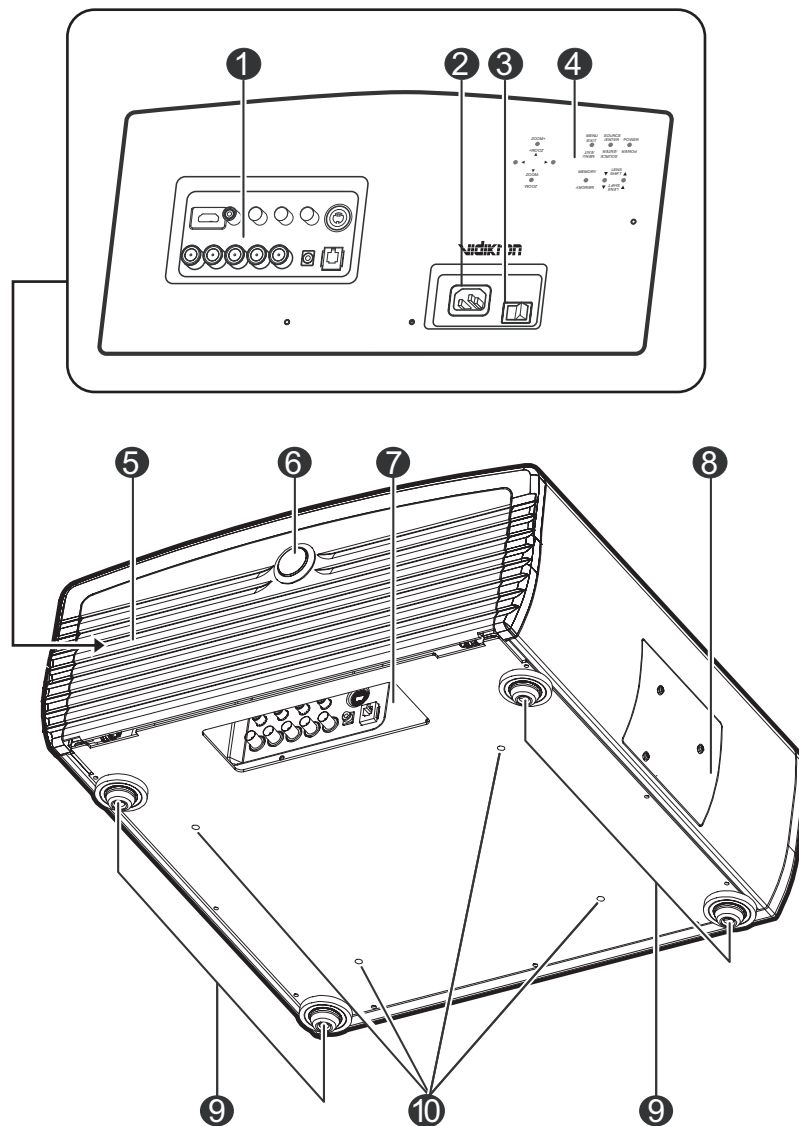
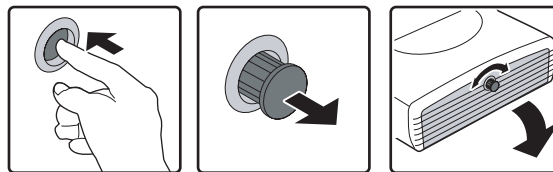

Figure 2-2. Vision 50 Rear/Bottom/Side View

1. **CONNECTOR PANEL**
Refer to *Vision 50 Connector Panel*, below.
2. **POWER INPUT (100 to 240 VAC)**
Connect the Vision 50 to power here.
3. **MAIN POWER SWITCH**
Disconnects or applies power to the Vision 50.
4. **BUILT-IN KEYPAD**
Refer to *Built-In Keypad* on page 8.
5. **CABLE ACCESS DOOR**
Open to access connectors.
6. **DOOR RELEASE BUTTON**
7. **CABLE OPENING**
Pass cables through this opening.
8. **LAMP MODULE COVER**
Remove this cover to access the lamp compartment.
9. **FRONT/REAR ADJUSTERS**
Use these to adjust the projector height or projection angle.
10. **CEILING MOUNT HOLES**
Use these to attach the ceiling bracket to the projector.

To access the connector panel, press the door release button so it pops out. Turn the knob clockwise or counter-clockwise and pull gently on it to open the door.



2.2 Vision 50 Connector Panel

Figure 2-3 shows the Vision 50 connector panel.

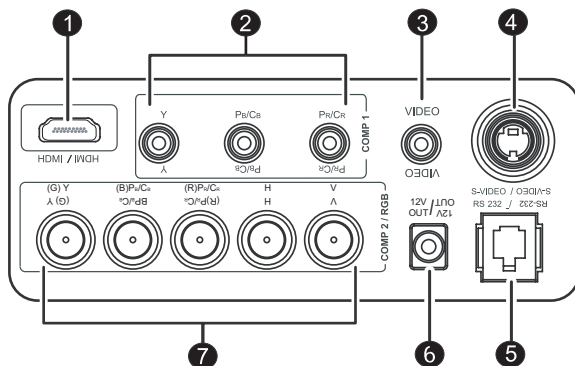

Figure 2-3. Vision 50 Connector Panel

1. **HDMI (Digital)**
HDCP-compliant digital video input for connecting a DVD player or HD tuner with a DVI or HDMI output.
2. **COMP 1 (RCA connectors)**
Standard Definition (480i/576i) Component (YPbPb) input. This is the input for component video from sources such as DVD players.



Tip

For best results, do not run your DVD player in progressive mode.

3. **COMPOSITE VIDEO INPUT**
Standard composite video input for connecting a VCR, laser disc player or other composite video source.
4. **S-VIDEO**
A standard S-Video input for connecting a DVD player, satellite receiver or Super VHS (S-VHS) VCR.
5. **RS-232 CONTROL PORT**
A female, RJ-11 connector for interfacing with a PC or home theater automation/control system.
6. **12-VOLT (250 mA) TRIGGER OUTPUT (3.5-mm, mini phono jack)**
Connection for a 12-volt trigger-controlled device. This can be a retractable screen, screen mask or the Vidikron CineWide with AutoScope system.
7. **COMP 2 / RGB**
Five, BNC connectors for connecting either RGB or component (YPbPr) high-definition television signals. (The Vision 50 automatically detects the signal format.)

2.3 Built-In Keypad

To control the projector when signals from a remote control cannot reach it, use the built-in keypad next to the connector panel.

Because the built-in keypad has fewer keys than the remote keypad, certain projector functions are accessible only through the menu system rather than via a direct key.

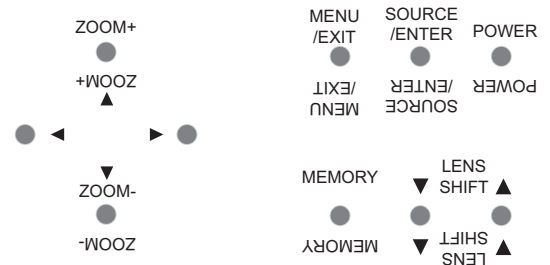

Figure 2-4 shows the Vision 50 remote control, and the paragraphs that follow describe its functionality.

2.4 Vision 50 Remote Control

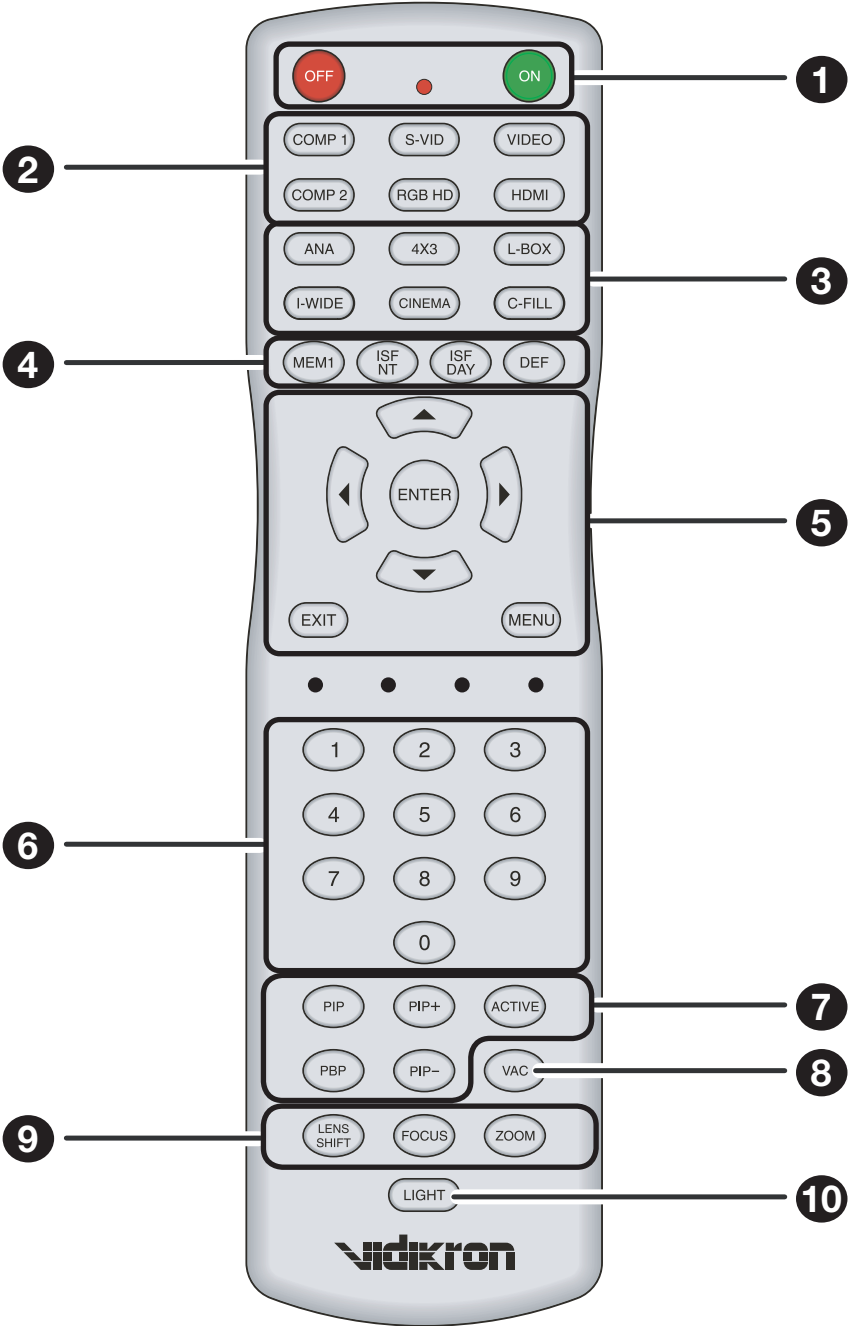

Figure 2-4. Vision 50 Remote Control

1. **ON / OFF**

Use these buttons to turn the projector on or off.

2. **Source Selection Buttons:**

COMP 1 (SD Component)

Press to select Component 1 (SD 480i/576i) video input as the source.

S-VID (S-Video)

Press to select the S-Video input as the source.

VIDEO

Press to select Composite video input as the source.

COMP 2 (HD Component)

Press to select Component 2 (HD 480p/576p/720p/1080i) video input as the source.

RGB HD

Press to select the Component 2 RGB input.

HDMI

Press to select the HDMI input.

3. **Aspect Ratio Selection Buttons**

Use these buttons to select an aspect ratio directly, as follows:

ANA (Anamorphic)

For viewing 16:9 DVDs or HDTV programs in their native aspect ratio.

4X3 (Standard 4:3)

Scales the input signal to fit 4:3 display mode in the center of the screen.

L-BOX (Letterbox)

For viewing LaserDisc movies or non-anamorphic DVDs on a 16:9 screen.

I-WIDE (IntelliWide)

Enlarges a 4:3 image horizontally in a NON-linear fashion to fit 16:9 full screen display.

CINEMA

For viewing 2.35:1 source material.

C-FILL (CineWide-equipped projectors only)

Selects the Cinema Fill aspect ratio, used for viewing 16:9 source material on a 2.35:1 screen.

4. **Memory Preset Buttons:**

MEM1

Press to recall settings for the current input from the "Custom 1" memory preset.

ISF NT

Press to recall settings for the current input from the "ISF Night" memory preset.

ISF DAY

Press to recall settings for the current input from the "ISF Day" memory preset.

DEF

Press to recall the factory-default settings for the current input.

5. **Cursor Keys (▲, ◀, ▼, ▶)**

Use these buttons to select items or settings, adjust settings or switch display patterns.

EXIT

Press to save menu item setting(s), exit the current menu and return to the previous one.

ENTER

Press to select a highlighted menu item or confirm a changed setting.

MENU

Press this button to show or hide the on-screen display (OSD) controls.

6. **0 - 9**

Use these keys to enter menu passcodes.

7. **Picture-In-Picture (PIP) / Picture-By-Picture (PBP) Controls:**

PIP

Press to activate PIP mode.

PIP+

Press to enlarge the PIP window.

ACTIVE

Press to switch to the active window in PIP or PBP mode.

PBP

Press to activate PBP mode.

PIP-

Press to shrink the size of the PIP window.

8. **VAC (V² Aperture Control)**

Adjusts the lens aperture (iris) setting according to the ambient light level in the viewing area.

9. **Motorized Lens Controls:**

LENS SHIFT

Press to access the lens shift controls.

FOCUS

Press to focus the image.

ZOOM

Press to reduce or enlarge the projected image size.

10. **LIGHT**

Press to illuminate the buttons.

2.5 Remote Control/Built-In Keypad Functional Comparison

Figure 2-5 shows remote control buttons that are duplicated on the built-in keypad.

Some functions such as power ON/OFF are combined in one button on the built-in keypad; however, the function is the same. This user manual describes the functions based on the remote control.

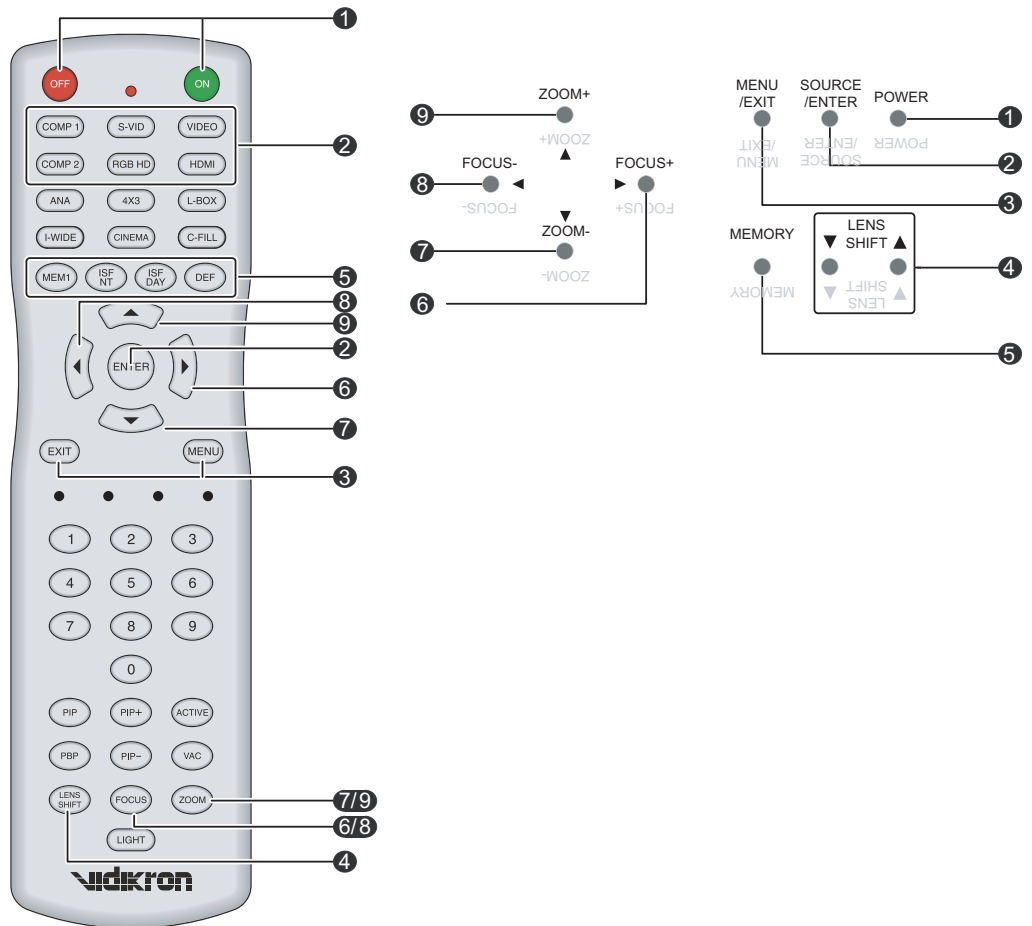
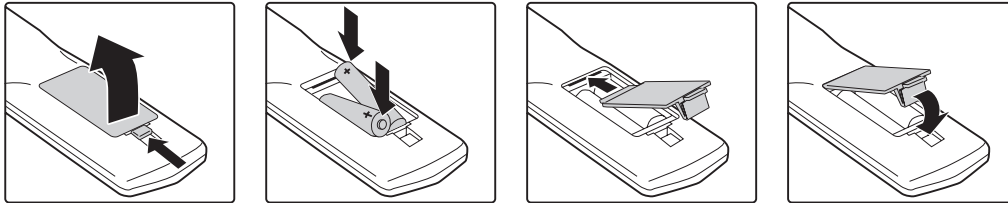

Figure 2-5. Remote Control/Built-In Keypad Functional Cross-Reference

To install batteries in the remote control, push the battery cover and slide it off. Install the two AAA batteries with the correct polarity and then replace the cover.



- Make sure that the battery polarities are correct when installing the batteries.
- Do not mix an old battery with a new one or different types of batteries.
- If you will not use the remote control for a long time, remove the batteries to avoid damage from battery leakage.
- Make sure that there is nothing obstructing the infrared beam between the remote control and the IR receiver on the projector.
- If the effective range of the remote control decreases, or it stops working, replace the batteries with new ones.
- The remote control may fail to operate if the infrared remote sensor is exposed to bright sunlight or fluorescent lighting.
- Ambient conditions may possibly impede the operation of the remote control. If this happens, point the remote control at the projector, and repeat the operation.
- The Ø icon appears on the screen when you press a button for an unavailable function.

3.1 Remote Control

◀ Notes on Batteries

◀ Notes on Remote Control Operation

3.2 Quick Setup

Table 3-1 gives a quick overview of the Vision 50 installation process. The sections following this one provide detailed instructions.



Note

Installation should be performed by a qualified custom video installation specialist.

Table 3-1. Installation Overview

Step	Procedure	For Details, Refer to page...
1	Choose a location for the projector	15
2	If installing a Vision 50/CineWide or Vision 50/CineWide with AutoScope: Install fixed CineWide base plate or AutoScope lens motor (optional)	19
3	Mount the projector	24
4	Connect signal sources to the Vision 50	25
5	Connect external controller to RS-232 port (optional)	29
6	Connect 12-volt trigger output to AutoScope lens motor or other equipment (optional)	30
7	Apply power to the projector	31
8	Change the OSD Language (optional)	32
9	For rear-screen and/or ceiling-mount installations, select the proper picture orientation	32
10	Primary lens adjustments: projected image size (zoom), position (shift) and focus	17, 32
11	Install CineWide anamorphic lens (optional)	33
12	CineWide lens adjustments: position, pitch (angle), geometry and focus	38
13	Projector calibration: adjust the following for each input , starting with Component 1; save settings when finished: <ul style="list-style-type: none"> • Aspect ratio • Brightness • Contrast • Color level • Tint • Input position 	51 through 57

Proper installation of your projector will ensure the quality of your display. Whether you are installing a projector temporarily or permanently, you should take the following into account to ensure your projector performs optimally.

Choose the installation type that best suits your needs: front or rear screen, floor mount or inverted mount. Table 3-2 compares these various installation methods.

Table 3-2. Projector Installation Options

Advantages	Considerations
Front Screen, Floor Mount Installation	
<ul style="list-style-type: none"> • Easy to set up • Can be moved or changed quickly • Easy to access 	<ul style="list-style-type: none"> • Shares floor space with audience
Front Screen, Inverted Mount (ceiling) Installation	
<ul style="list-style-type: none"> • Does not take up audience space • Projector is unobtrusive • Projector cannot be accidentally moved 	<ul style="list-style-type: none"> • Installation is more permanent • Projector access is more difficult
Rear Screen, Floor Mount Installation	
<ul style="list-style-type: none"> • Projector is completely hidden • Projector is easily accessed • Usually good ambient light rejection 	<ul style="list-style-type: none"> • Requires separate room • Installation cost is usually higher
Rear Screen, Inverted Mount (ceiling) Installation	
<ul style="list-style-type: none"> • Projector is completely hidden • Usually good ambient light rejection 	<ul style="list-style-type: none"> • Requires separate room • Installation cost is usually higher
Rear Screen, Floor Mount with Mirror	
<ul style="list-style-type: none"> • Projector is completely hidden • Usually good ambient light rejection • Requires less space behind screen than other rear screen installations 	<ul style="list-style-type: none"> • Requires separate room • Installation cost is usually higher

In general, minimize or eliminate light sources directed at the screen. Contrast ratio in your images will be noticeably reduced if light directly strikes the screen, such as when a shaft of light from a window or floodlight falls on the image. Images may then appear washed out and less vibrant.

3.3 Installation Considerations

◀ Installation Type

◀ Ambient Light

Throw Distance ➤ Throw distance is the distance measured from the front of the projector to the screen. This is an important calculation in any projector installation as it determines whether or not you have enough room to install your projector with a desired screen size and if your image will be the right size for your screen.

You can quickly estimate the throw distance by taking the width of the screen and multiplying it by the lens throw ratio; see Figure 3-1. The result of this calculation tells you roughly how far back the projector should be positioned from the screen in order to project a focused image large enough to fill the screen.

Estimating Throw Distance

Throw Distance (TD) = Screen Width (w) x Lens Throw Ratio

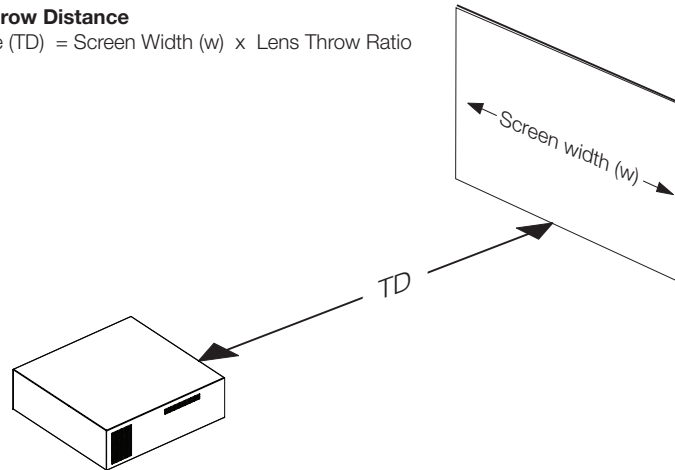

Figure 3-1. Estimating Throw Distance

Table 3-3 gives the throw ratios for the Vision 50, Vision 50/CineWide and Vision 50/CineWide with AutoScope.

Table 3-3. Throw Ratios for the Vision 50 Series

Projector Model	Throw Ratio with Primary Lens Only	Throw Range in inches, with 72.6x40.8-inch (1.78:1) Screen		Throw Ratio with Primary Lens and Anamorphic Lens	Throw Range in inches, with 96x40.8-inch (2.35:1) Screen	
		Minimum	Maximum		Minimum	Maximum
Vision 50	1.82 – 2.37	132.13	172.06		(n/a)	
Vision 50/CineWide		(n/a)		1.92 – 2.37	184.32	227.52
Vision 50/CineWide with AutoScope	1.82 – 2.37	132.13	172.06	1.41 – 1.76	135.36	168.96

Proper placement of the projector relative to the screen will yield a rectangular, perfectly-centered image that completely fills the screen.

◀ **Vertical and Horizontal Position**

Ideally, the projector should be positioned perpendicular to the screen and in such a way that the lens center and screen center are aligned with each other, as shown in Figure 3-2.

Ceiling Installation

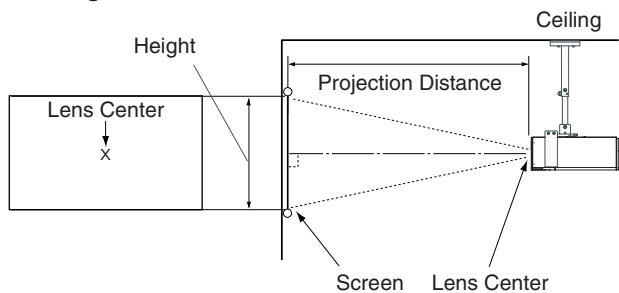

Floor Installation

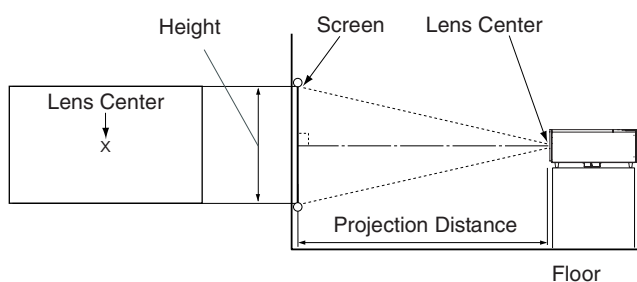
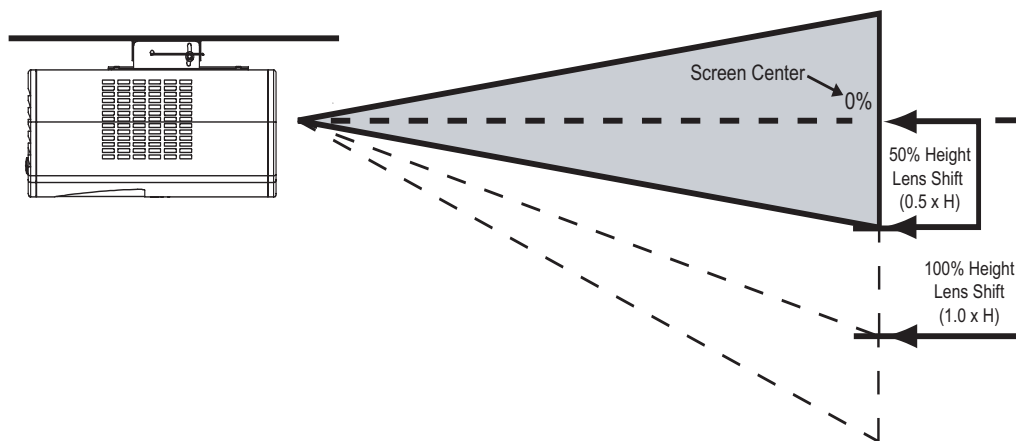

Figure 3-2. Projector Placement

If it is not possible to align the projector and screen as shown in Figure 3-2, you can use the lens shift (LENS) controls on the projector remote to center the image on the screen. Vertical lens shift is generally expressed as a percentage of the screen height, as shown in Figure 3-3.

◀ **Vertical Lens Shift**



Note: This is a general example of lens shift. Lenses vary in their shift capabilities. **No particular lens or projector is used in this example.**

Figure 3-3. Vertical Lens Shift (Example Only)

The Vision 50 provides up to 50% of vertical lens shift in either direction. For example, with a 96 x 54-inch (16:9) screen, you can shift the image up to 27.00 inches (0.69 meters) above or below the screen center.

Folded Optics ➤ In rear-screen applications where space behind the projector is limited, a mirror may be used to fold the optical path, as shown in Figure 3-4. The position of the projector and mirror must be accurately set. If you are considering this type of installation, contact your dealer for assistance.

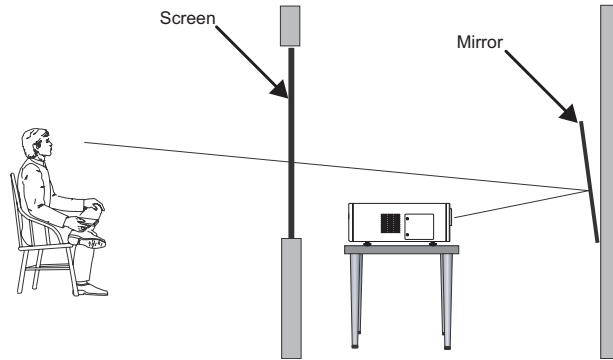

Figure 3-4. Folded Optics

Other Considerations ➤ Other considerations and tips that can help improve your installation:

- Keep the ambient temperature constant and below 35°C (95°F). Keep the projector away from heating and/or air conditioning vents. Changes in temperature may cause drifts in the projector circuitry, which may affect performance.
- Keep the projector away from devices that radiate electromagnetic energy such as motors and transformers. Common sources of these include slide projectors, speakers, power amplifiers and elevators.

If you are installing a standard (non-CineWide) Vision 50, skip this step and proceed with **Mounting the Vision 50** (page 24).

If you are installing a Vision 50/CineWide, proceed with **Installing the Fixed CineWide Base Plate (Vision 50/CineWide)** (page 23).

If you are installing a Vision 50/CineWide with AutoScope, proceed as follows to install the AutoScope lens motor.

**Note**

1. *Do not install the CineWide lens yet, only the fixed CineWide base plate or AutoScope lens motor. You will install the CineWide lens after you install the projector and adjust the primary lens.*
2. *Some components shipped with your projector may differ slightly from what is shown in these instructions.*

3.4 Installing the Optional CineWide Lens Mount

Installing the AutoScope Lens Motor (Vision 50/CineWide with AutoScope)

Figure 3-5 shows the Vision 50/CineWide with AutoScope motor assembly.

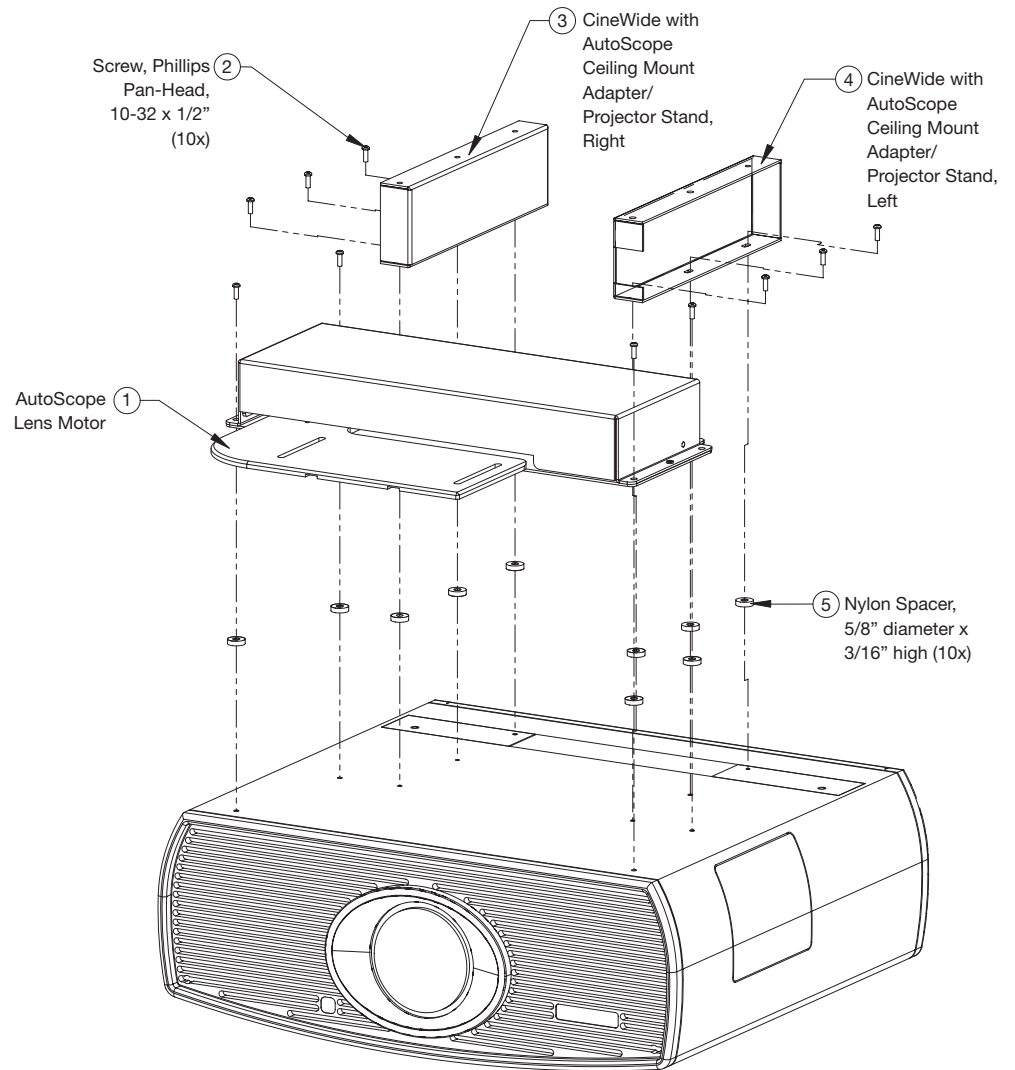
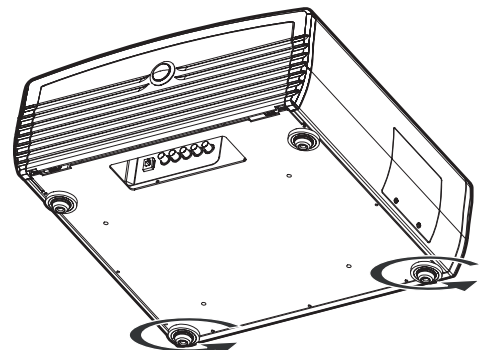

Figure 3-5. Vision 50/CineWide with AutoScope Motor Assembly – Exploded View

Remove Projector Front Height Adjusters:

Place the projector upside down on a blanket or other soft surface. Then, remove the two height adjusters at the front of the projector by turning them counterclockwise until they come out.



Install Ceiling Mount Adapters/Projector Stands: For ceiling installations, these brackets bring the mounting points for the projector mounting rails (included with the projector ceiling mount kit) from the bottom of the projector up and around the AutoScope lens motor housing. For floor installations (where the projector is upright), the adapters allow the projector to lie flat on the mounting surface.

Using six (6) each of the supplied, 10-32 x 1/2" Pan-Head Phillips screws (item #2) and nylon spacers (item #5), attach the AutoScope Ceiling Mount Adapters/Projector Stands (items #3 and #4) to the projector as shown in Figure 3-6.

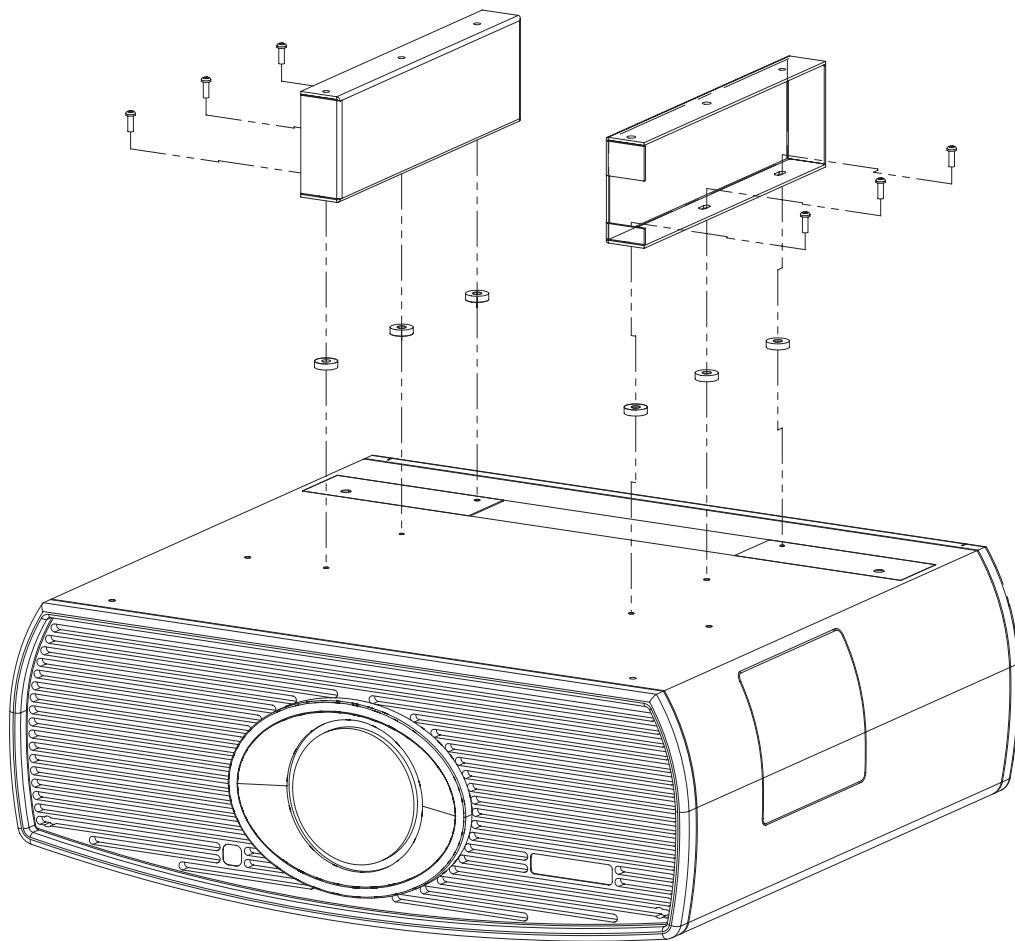

Figure 3-6. Vision 50 with Ceiling Mount Adapters/Projector Stands



Caution

DO NOT OVER-TIGHTEN THE SCREWS.

Install Lens Motor: Position the AutoScope Lens Motor (item #1) as shown in Figure 3-7. Line up the mounting holes on the lens motor housing with those on the underside of the projector. Secure the motor to the projector with the four remaining 10-32 x 1/2" Pan-Head Phillips screws (item #2) and nylon spacers (item #5).

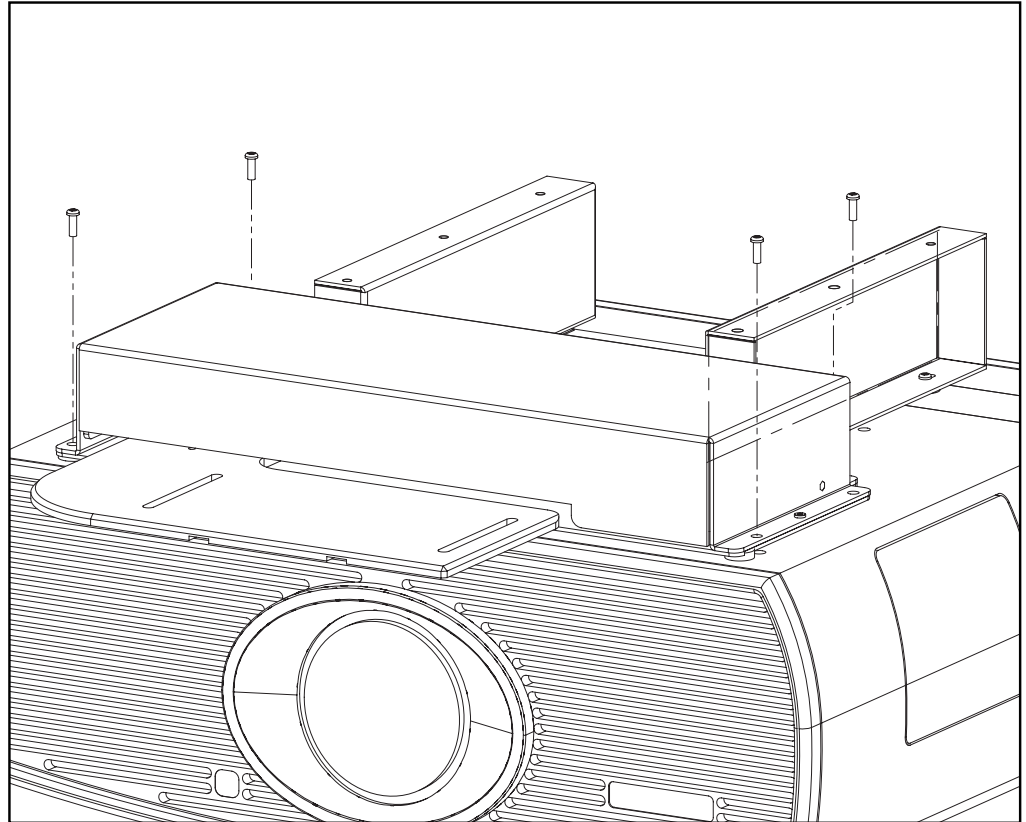

Figure 3-7. AutoScope Lens Motor Installation

After you have installed the AutoScope lens motor, proceed with **Mounting the Vision 50** on page 24.

To install the fixed CineWide base plate on a Vision 50/CineWide:

1. Place the projector upside down on a blanket or other soft surface.
2. Line up the four mounting holes on the CineWide base plate with those on the bottom of the projector.
3. **If you are mounting the Vision 50/CineWide on a ceiling:** Line up the four holes on the projector ceiling mounting plate (included with the projector ceiling mount kit) with those on the bottom of the projector.



Note

The hole pattern on the CineWide base plate is identical to that on the ceiling mounting plate.

4. Secure the CineWide base plate (and ceiling mounting plate, if needed) to the projector with the four, M6x16mm screws and washers provided with the CineWide lens base plate. See Figure 3-8.



Caution

1. Do not use the mounting screws provided with the ceiling mounting plate. Use only the hardware provided with the CineWide lens base plate.

2. **DO NOT OVER-TIGHTEN THE SCREWS.**

Vision 50/CineWide with Lens Base Plate

Vision 50/CineWide with Lens Base Plate and Ceiling Mounting Plate

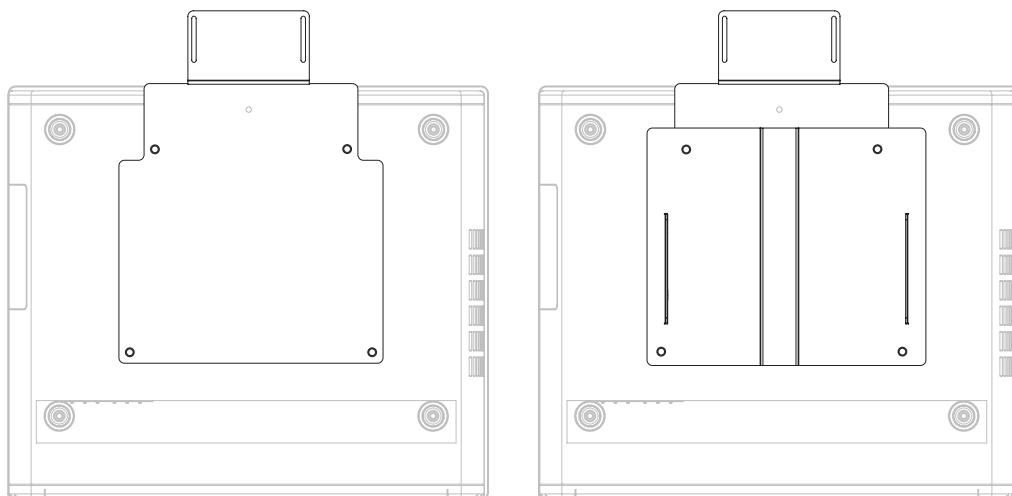

Figure 3-8. Vision 50/CineWide with Anamorphic Lens Base Plate and Ceiling Mounting Plate - Bottom View

3.5 Mounting the Vision 50

There are several methods for mounting the projector. Depending on your chosen installation, one method may be more suitable than another.

Floor Mounting (Upright) ➤ In typical front and rear screen installations, the projector can be placed upright on a secure and level surface such as a table or cart. Carts are useful when moving a projector during a presentation or from site to site. If possible, lock the wheels when it's in position to prevent it from being moved during a presentation.

Ceiling Mounting (Inverted) ➤ For fixed installations, and for those that want the projector out of sight or have a limited space for projector and audience, you can invert the Vision 50 and suspend it from the ceiling using a specially-designed ceiling mount fixture.



Caution

Use only the Vidikron-approved ceiling mount kit designed for your projector (part number VIHk-000425, or VIHk-000175 for a Vision 50/CineWide with AutoScope). Install the mount kit according to the instructions provided with it.

Tighten all screws securely, but do not over-tighten them. This is particularly important when ceiling-mounting a Vision 50/CineWide with AutoScope, because the anamorphic lens and lens motor shift the center of gravity toward the front of the projector.

The projector can also be inverted and placed in an enclosure above and behind the viewing area. Install four feet on the inside bottom surface of the enclosure on which the projector can rest. A variety of materials can be used for this purpose (for example, rubber crutch tips or turntable feet).

Adjusting the Projector Height or Projection Angle ➤

If the screen is significantly higher or lower than the projector, you can also tilt the projector at a slight angle. In a ceiling installation, you do this by adjusting the ceiling mount.

For a floor installation, turn the four adjustable feet on the bottom of the projector to adjust the projector height and/or projection angle.

If you do this, you may need to make keystone adjustments or vertically shift the image using the on-screen display (OSD) controls, to compensate. For detailed instructions, refer to **Using the On-Screen Menus** on page 44.

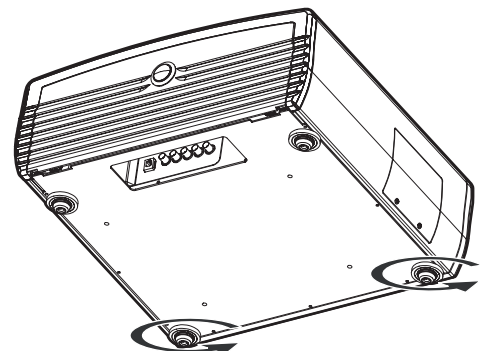

Proceed as follows to connect the Vision 50 to your video sources, external controller(s) – if present – and AC power.

When connecting your equipment:

- Turn off all equipment before making any connections.
- Use the correct signal cables for each source.
- Ensure that the cables are securely connected. Tighten the thumbscrews on connectors that have them.

To access the connector panel, press the door release button so it pops out. Turn the knob clockwise or counter-clockwise and pull gently on it to open the door.

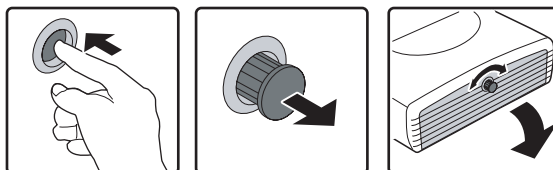

3.6 Connections to the Vision 50

◀ Connector Panel Access

Connect your video sources to the Vision 50 as shown and described in the sections that follow.

◀ Connecting Source Components to the Vision 50

HDMI/DVI Connections: See Figure 3-9. With an HDMI source, use the included HDMI-to-HDMI cable; with a DVI source, use the included DVI-to-HDMI cable.



Tip

Use the HDMI input whenever possible. This ensures the highest video quality because the signal is carried in the digital domain throughout the entire signal path, from source component output into the projector.

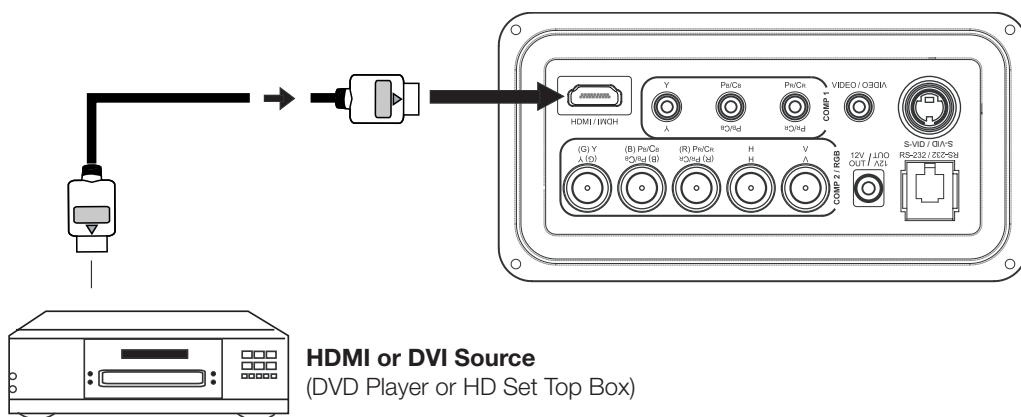

HDMI or DVI Source
(DVD Player or HD Set Top Box)

Figure 3-9. HDMI/DVI Source Connections

RGB Connections: Connect your personal computer or other RGB source (DVD player or HD set top box) to the **COMP 2/RGB** input; see Figure 3-10. You can use the included DB15HD-to-5 x BNC cable if your RGB source has a 15-pin, VGA-type connector.



Note

The Vision 50 supports computer resolutions of 1024x768, 800x600 and 640x480.

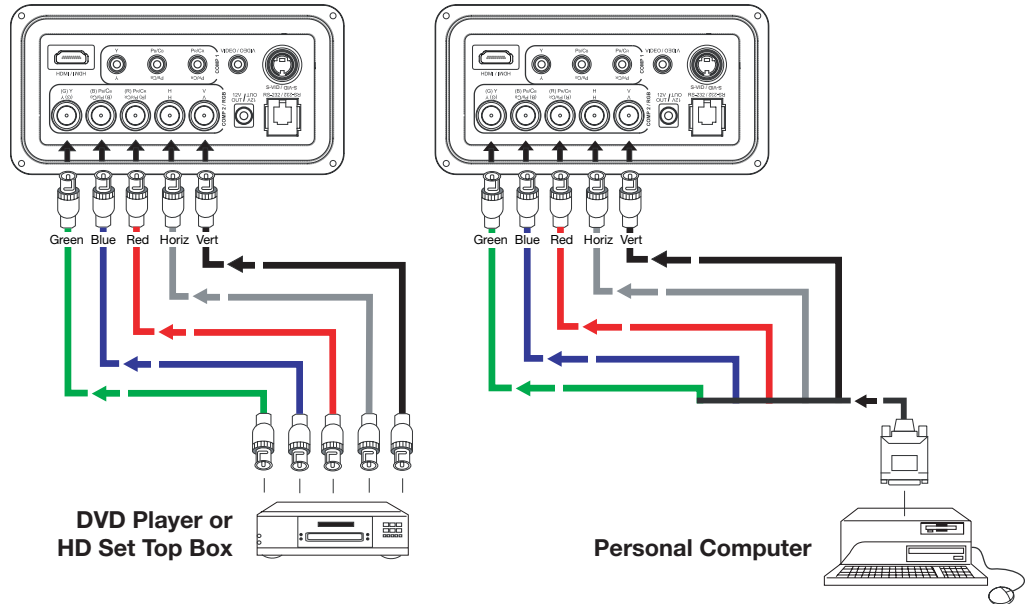

Figure 3-10. RGB Connections

Progressive Component Video Connections: Connect your progressive component source (DVD player or HD set top box) to the **COMP 2/RGB** input as shown in Figure 3-11.

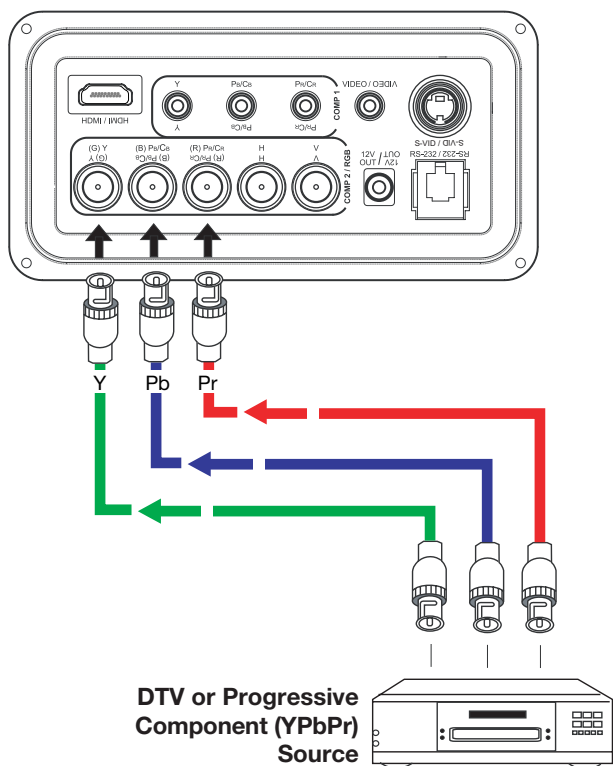

Figure 3-11. Progressive Component Video Connections

Composite/S-Video/Component Video Connections: Use the included cables to connect your composite, S-Video and SD (480i) component video sources to the Vision 50 as shown in Figure 3-12.

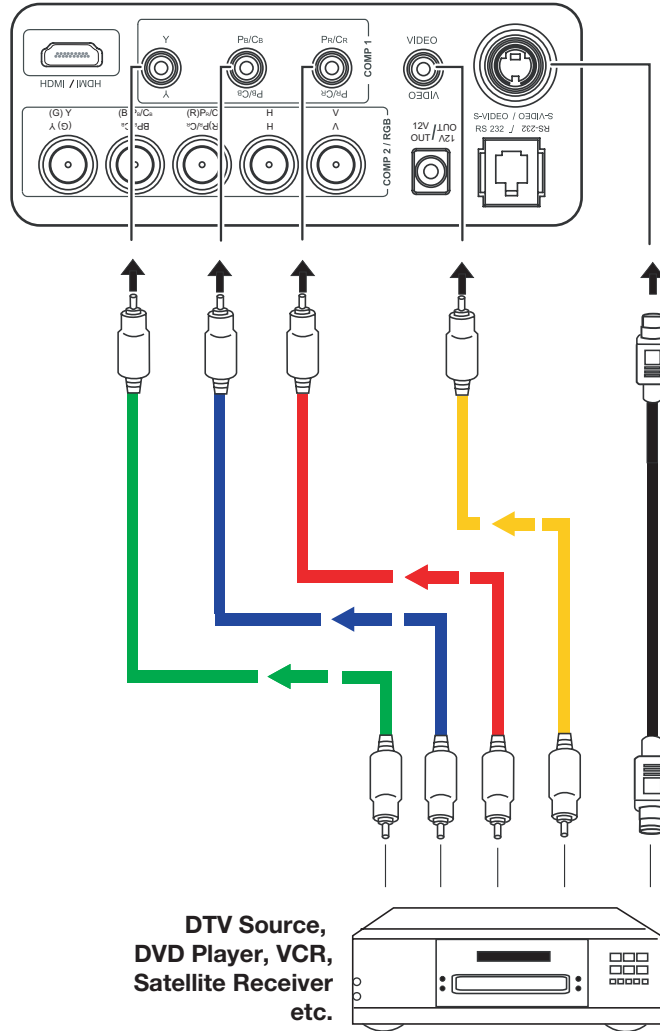
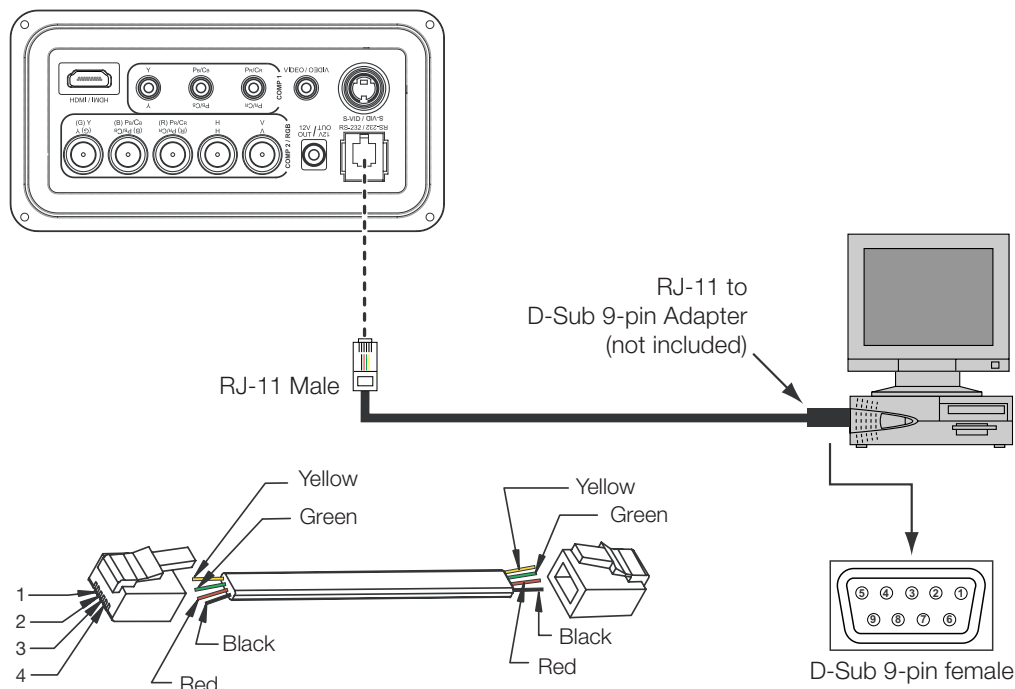

Figure 3-12. Composite, S-Video and Component Video Connections

Connect a PC or home theater control/automation system (if present) to the RS-232 port on the Vision 50; see Figure 3-13. Use a standard, 4-wire RJ-11 telephone cable, wired straight-through.

◀ **RS-232 Controller Connection**

For more information about using this connection, refer to **Serial Communications** on page 67.



RS-232 Adapter Wiring		
D-Sub 9-pin female	4-pin RJ-11	Function
2	2	Transmit Data
3	3	Receive Data
5	1, 4	Ground
1, 4, 6, 7, 8, 9	--	Not Connected

Figure 3-13. RS-232 Control System Connection

Connecting 12-volt Trigger Output to External Theater Equipment

If your Vision 50 is equipped with a CineWide with AutoScope system, use the cable supplied with the AutoScope Lens Motor to connect the motor to the 12-volt trigger output as shown in Figure 3-14.

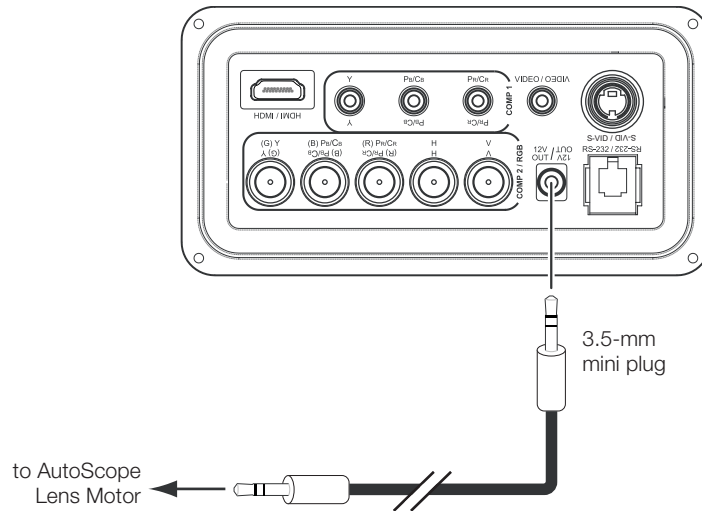

Figure 3-14. Connecting the 12-volt Trigger Output to the AutoScope Lens Motor

If your home theater contains a retractable screen, screen mask or other 12-volt trigger-activated equipment, use the cable supplied with the Vision 50 to connect it to the 12-volt trigger output as shown in Figure 3-15.

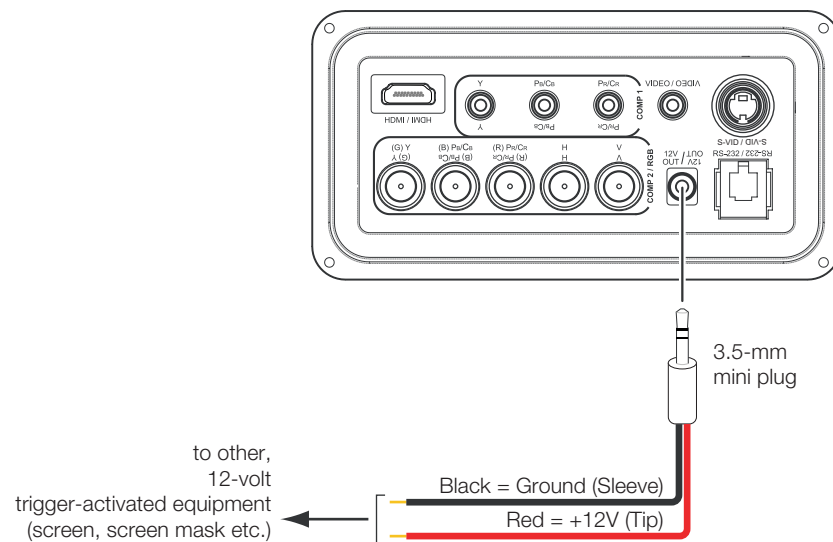
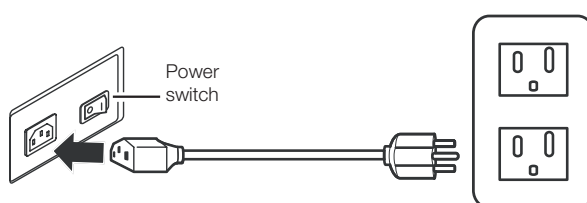

Figure 3-15. Connecting the 12-volt Trigger Output to Other Equipment

Projector: The Vision 50 ships with various types of AC power cords. Choose the one that is appropriate to your locale.

Plug the female end of the power cord into the AC receptacle on the rear of the projector (AC 100V ~ 240V). Then, connect the other end to your AC power source.



◀ Connecting to AC Power

AutoScope Lens Motor: With AutoScope-equipped projectors, an additional power cord is provided for the lens motor. Plug the female end of the AC power cord into the AC input on the rear of the lens motor assembly. Connect the other end to a 110 VAC power source.



Caution

*The input voltage to the AutoScope lens motor must be between 100 and 120 VAC. **Do not connect the AutoScope lens motor to a 200-240 VAC power source!***

AutoScope Lens Motor (Rear)

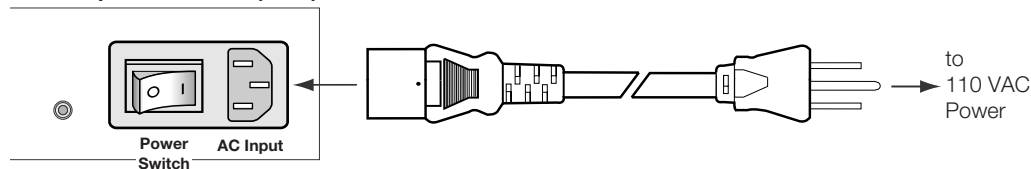

1. Turn on your source components.
2. If this is an AutoScope-equipped projector, turn on the main power switch at the rear of the AutoScope lens motor. The lens motor power switch is located next to the AC input (see above).
3. Turn on the main power switch at the rear of the projector. The POWER LED lights orange. The LAMP and TEMP LEDs light red briefly, then go out.
4. Press the **ON** button on the remote control to turn on the Vision 50. The POWER LED flashes orange to indicate that it is warming up.
5. When the projector is ready for use, the POWER LED lights green.
6. "Searching..." appears on the screen before the Vision 50 identifies the input signal and remains there until a valid signal is detected.
7. If an incompatible input signal exceeds the range of the projector, a "No signal supported" message appears on the screen. This message remains on the screen until you change the input signal.

3.7

Turning on the Power

3.8 Changing the OSD Language

The Vision 50 OSD language is initially set to English, but can also display the menus in French, Spanish, Italian or German. To change the OSD language:

1. Press **MENU**.
2. Select Installation from the Main Menu and press **ENTER**.
3. Select Language from the Installation Menu and press **ENTER**.
4. Press **▲** or **▼** to highlight the desired language. (The change takes effect immediately.)

3.9 Adjusting the Picture Orientation

By default, the Vision 50 is configured for a "floor/front" installation, in which the projector is installed upright and in front of the screen. If it is installed behind the screen and/or mounted on a ceiling, you must change the picture orientation. To do this:

1. Press **MENU** on the remote control.
2. Select Installation from the Main Menu and press **ENTER**.
3. Select Picture Orientation from the Installation Menu and press **ENTER**.
4. Choose Floor Rear, Ceiling Front or Ceiling Rear to match the installation method.

3.10 Primary Lens Adjustments

The Vision 50 gives you a great deal of control over the picture size, position and focus. To access the motorized lens controls, use the **FOCUS**, **ZOOM** and **LENS SHIFT** buttons on the remote control.

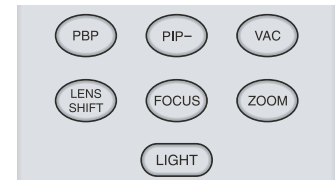

Focus ➤ To focus the projected image, press the **FOCUS** button, then use the left- and right-arrow buttons to adjust the focus.

Zoom ➤ To make the picture smaller (zoom out), press the **ZOOM** button, then use the left-arrow (**◀**) button.

To enlarge the picture (zoom in), press the **ZOOM** button, then use the right-arrow (**▶**) button.

Vertical Lens Shift ➤ To shift the projected image vertically, press the **LENS SHIFT** button, then use the up and/or down-arrow (**▲, ▼**) buttons.

If you are installing a CineWide-equipped projector, proceed as follows to install and adjust the CineWide anamorphic lens.



Note

It is extremely important that the primary lens is properly adjusted before you install the anamorphic lens. Ensure that the image from the primary lens is perfectly centered on the screen.

The standard Vision 50/CineWide uses a prismatic-style anamorphic lens. This type of lens compresses the height of the image (as opposed to stretching the width) to achieve a 2.35:1 aspect ratio with a 1.78:1 display device.

The Vision 50/CineWide with AutoScope uses a cylindrical anamorphic lens with a much larger aperture than the prismatic lens used with the standard Vision 50/CineWide.

If you are installing a Vision 50/CineWide with AutoScope, refer to **Anamorphic Lens Installation and Adjustment - Vision 50/CineWide with AutoScope** on page 36. If you are installing a standard Vision 50/CineWide, continue with the next section.

The standard Vision 50 Anamorphic lens mount kit consists of everything shown in Figure 3-16. Some components shipped with your projector may differ slightly from what is shown in these instructions.

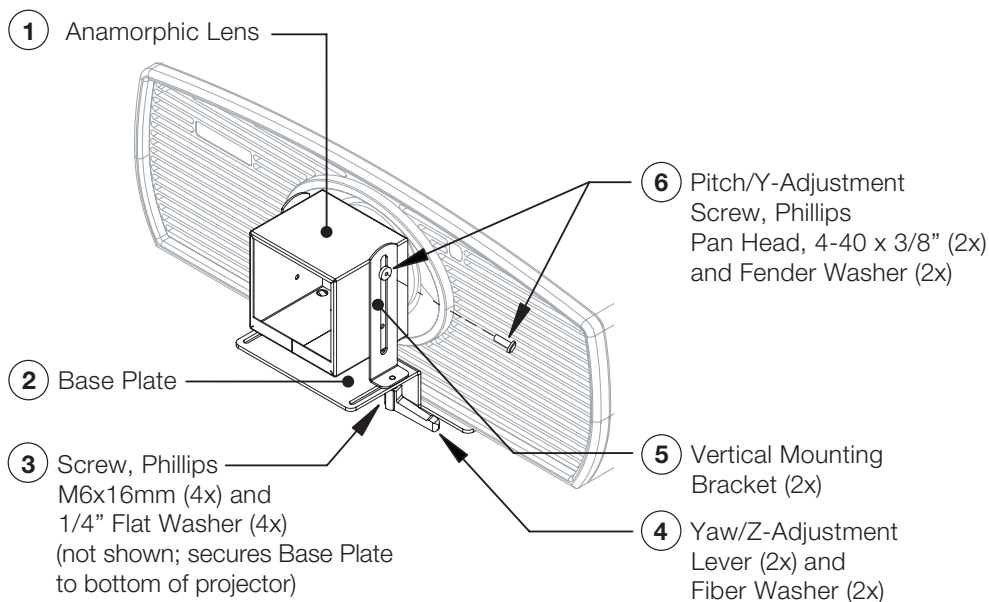

Figure 3-16. Standard Vision 50 Anamorphic Lens Mounting Assembly

3.11 Installing and Adjusting the CineWide Anamorphic Lens

◀ **Anamorphic Lens Installation and Adjustment - Vision 50/CineWide**

1. Use the Pitch/Y-Adjustment Screws and Washers (item #6) to attach the Vertical Mounting Brackets (item #5) to the Anamorphic Lens (item #1).
2. Place the lens with the brackets installed on top of (or under, if the projector is inverted) the Base Plate (item #2), so that the two threaded posts at the bottom of the brackets pass through the corresponding slots on the base plate.
3. Secure the lens assembly to the base plate with the Yaw/Z-Adjustment Levers and Fiber Washers (item #4).



Tip

To avoid clipping the corners of the image, position the anamorphic lens as close as possible to the primary lens.

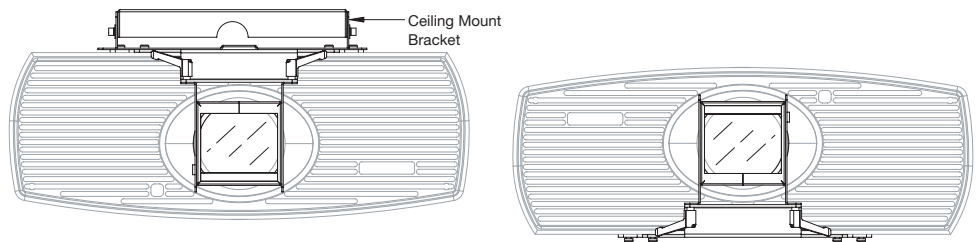

Adjusting the Lens Height (Y):

1. Project a white field on the screen.
2. Ensure that the two Pitch/Y-Adjustment Screws are loose enough to allow vertical movement of the lens assembly.
3. Slowly move the anamorphic lens into place so that there are no shadows on the top or bottom of the screen:

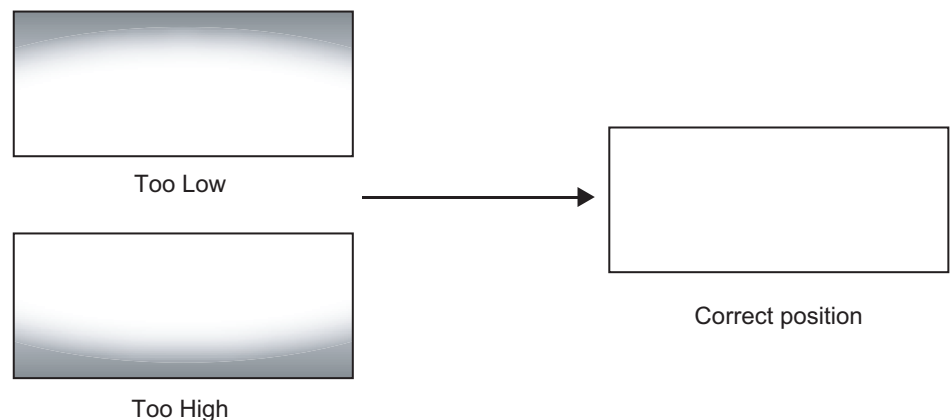

4. When the height is properly set, tighten the Pitch/Y-Adjustment Screws to secure the lens in place.

Adjusting the Pitch (Angle): Next, angle the lens to even out any top-to-bottom pincushion distortion. To do this, loosen the Pitch/Y-Adjustment Screws on either side of the lens to allow it to pivot freely. Then, adjust the anamorphic lens angle so that the projected image is rectangular:

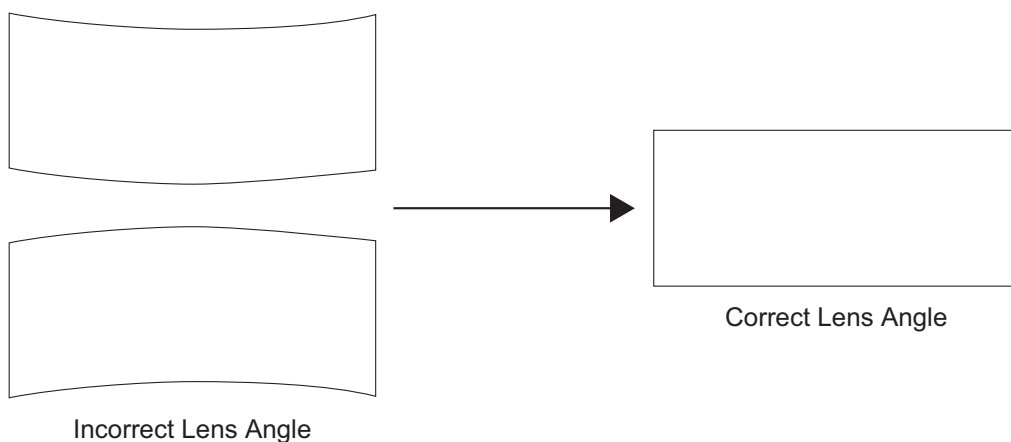

The anamorphic lens will almost always be angled with respect to the projector; this is normal.

Once the proper lens angle has been set, firmly tighten the Pitch Adjustment Screws to secure the lens in place.



Note

There may be some pincushion distortion even after the lens is properly adjusted, especially at shorter throw distances. If this is the case, Vidikron recommends that you slightly over-scan the image into the screen frame area to mask the distortion.

Adjusting the Yaw: Loosen the Yaw/Z-Adjustment Levers to allow the lens to pivot freely from side to side. Then, angle the lens to even out any left-right pincushion distortion:

Anamorphic Lens (Top View)

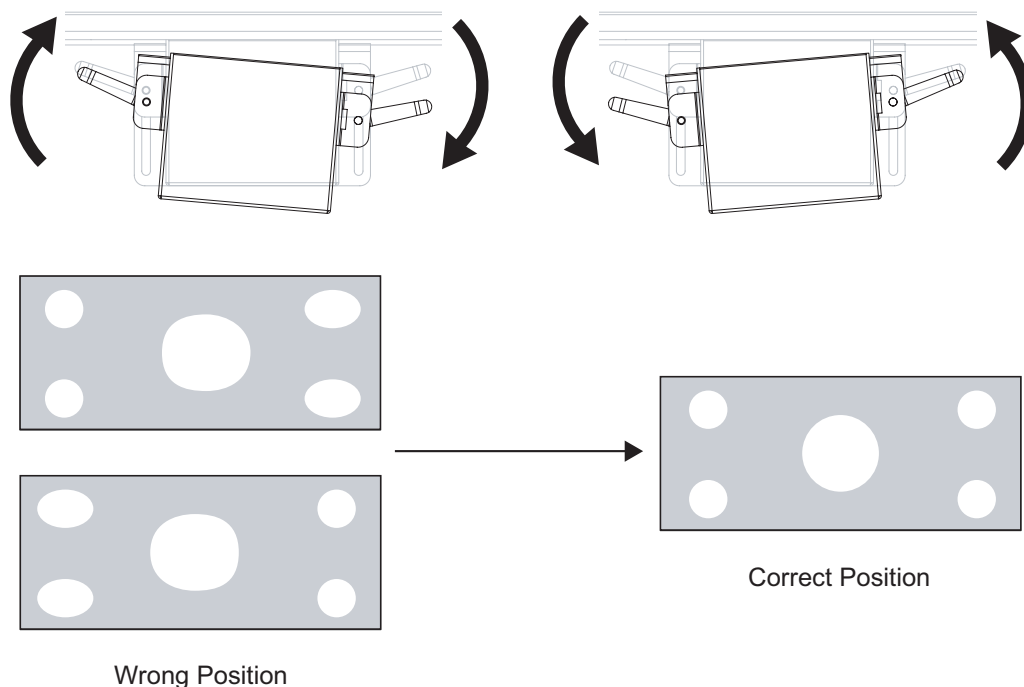

Anamorphic Lens Installation and Adjustment - Vision 50/CineWide with AutoScope

Once the proper lens angle has been set, firmly tighten the Yaw/Z-Adjustment Levers to secure the lens in place.

The Vision 50 Anamorphic lens mount kit consists of everything shown in Figure 3-17. Some components shipped with your projector may differ slightly from what is shown in these instructions.

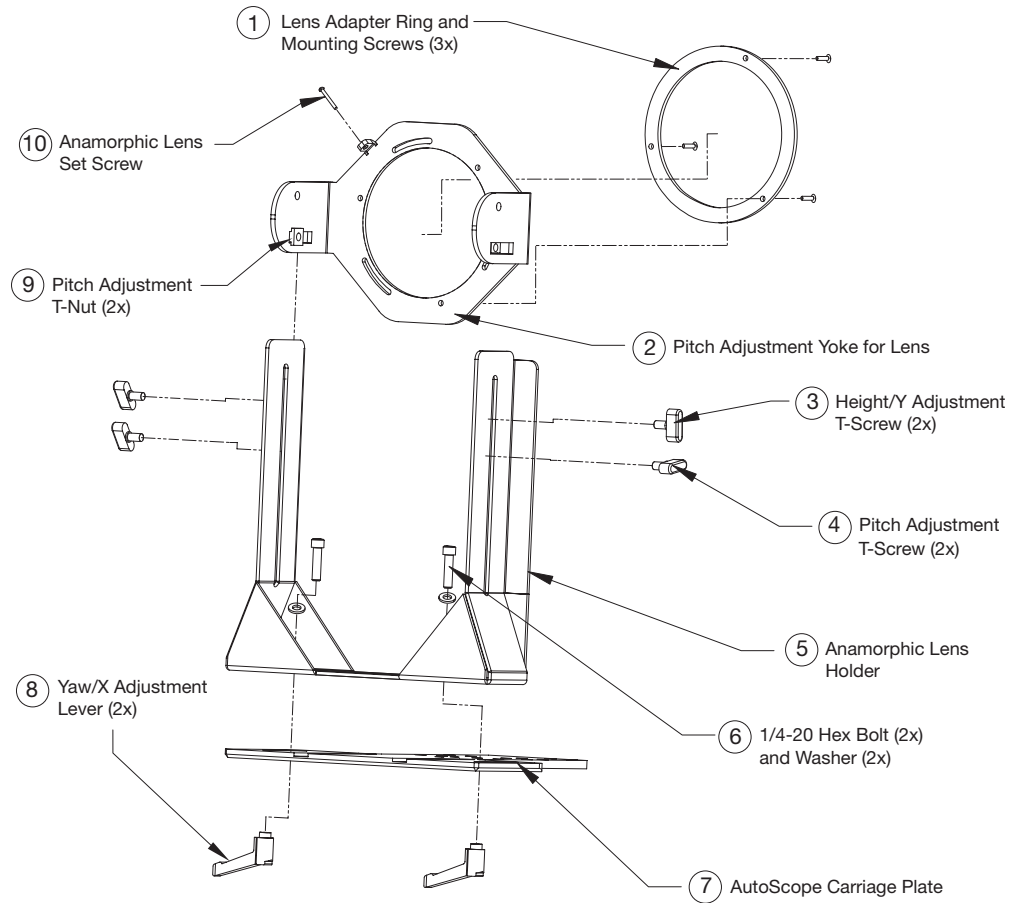
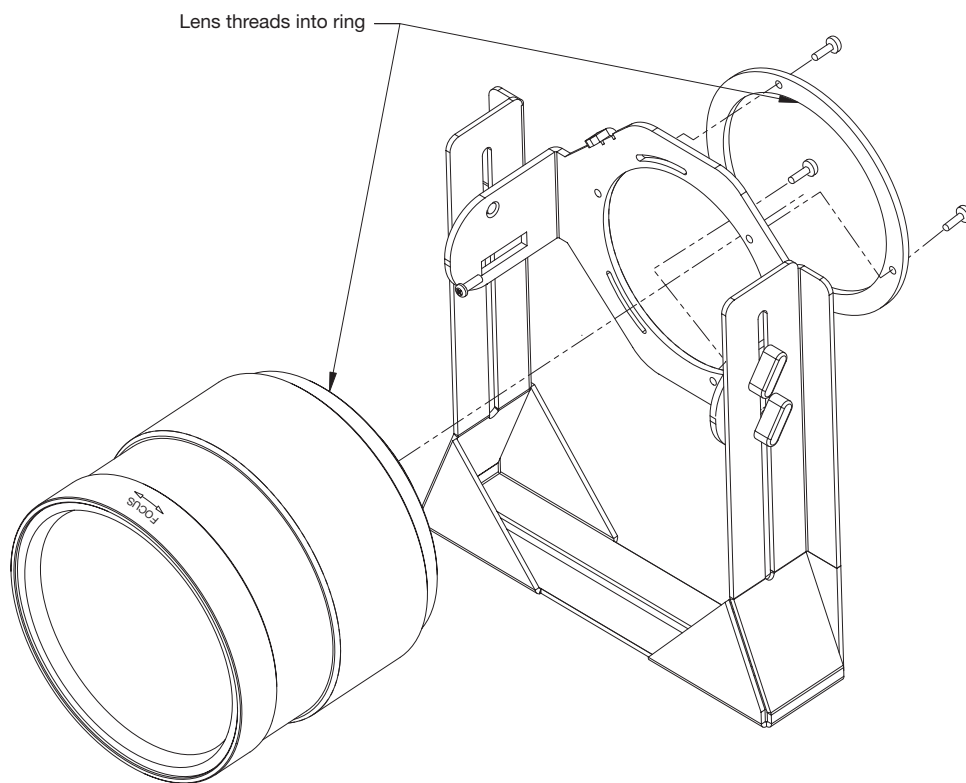

Figure 3-17. Anamorphic Lens Mounting Assembly - Exploded View

Attach Lens Mounting Assembly to Lens Motor Carriage Plate:

1. Remove the two Yaw/X Adjustment Levers (item #8) from the bottom of the Anamorphic Lens Holder (item #5).
2. Place the Anamorphic Lens Holder on top of the AutoScope Carriage Plate (item #7). Position the bracket so that the long slot at the bottom of the lens holder is perpendicular to the corresponding slots on the carriage plate.
3. Secure the Anamorphic Lens Holder to the plate using the Hex Bolts and Washers (item #6) and Yaw/X Adjustment Levers that you removed in Step 1.
4. Use the Lens Mounting Screws to attach the Lens Adapter Ring (item #1) to the Pitch Adjustment Yoke (item #2); see Figure 3-18. (Use the round, threaded holes on the yoke.)
5. Use the Height/Y Adjustment T-Screws (item #3), Pitch Adjustment T-Screws (item #4) and T-Nuts (item #9) to attach the Pitch Adjustment Yoke and Lens Adapter Ring to the Anamorphic Lens Holder. **The Yoke should be as close to the primary lens as possible.**
6. Attach the lens to the Lens Adapter Ring by threading it clockwise.

**Figure 3-18. Attaching the Anamorphic Lens to the Lens Adapter Ring**

Configure Lens Motor Trigger: CineWide with AutoScope maintains constant image height independent of the aspect ratio, while using the full display resolution of the projector. It accomplishes this by moving the anamorphic lens in front of the primary lens when widescreen material is being viewed. When the viewer transitions back to 16:9 or 4:3 source material, the anamorphic lens moves out of the light path.

To configure the lens motor trigger on the Vision 50 for proper AutoScope operation:

1. Press **MENU** on the remote control.
2. Select Service from the Main menu and press **ENTER**.
3. Use the number buttons on the remote to enter the Service menu passcode when prompted and press **ENTER** again. Then, press **MENU** on the remote control.
4. Select Screen Trigger Mode from the Service menu.
5. Set the Screen Trigger Mode to "Trigger." This enables the lens motor to move the anamorphic lens into position (in front of the primary lens) when the Cinema or Cinema Fill aspect ratio is selected.
6. Select the Cinema or Cinema Fill aspect ratio to move the anamorphic lens into position, if it isn't already. To do this, press **CINEMA** or **C-FILL** on the Vision 50 remote control (Figure 2-4).

Adjusting the Horizontal (X) Lens Position:

1. Project a white field on the screen.
2. Loosen the Yaw/X-Adjustment Levers underneath the lens.
3. Slowly move the anamorphic lens into place so that there are no shadows on either side of the screen:

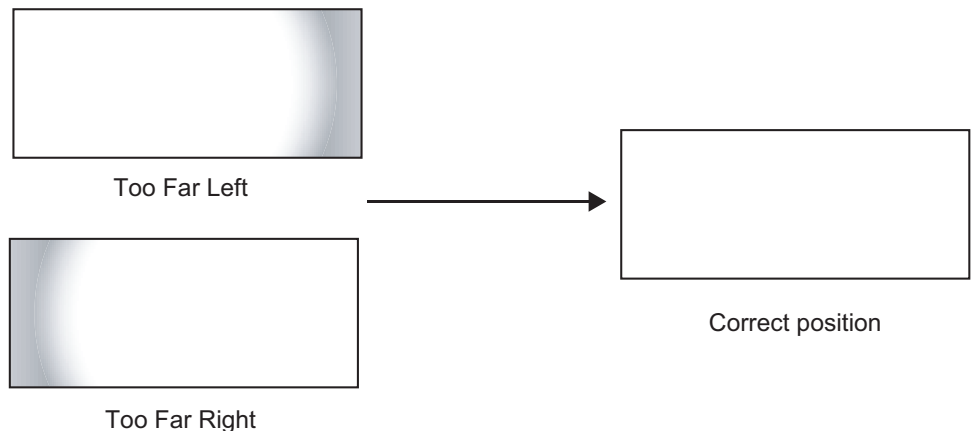

4. When the horizontal position is properly set, tighten the Yaw/X-Adjustment Levers to secure the lens in place.

Adjusting the Height (Y): With the white field still on-screen, loosen the Height/Y Adjustment T-Screws on either side of the lens. Then, slowly move the anamorphic lens into place so that there are no shadows on the top or bottom of the screen:

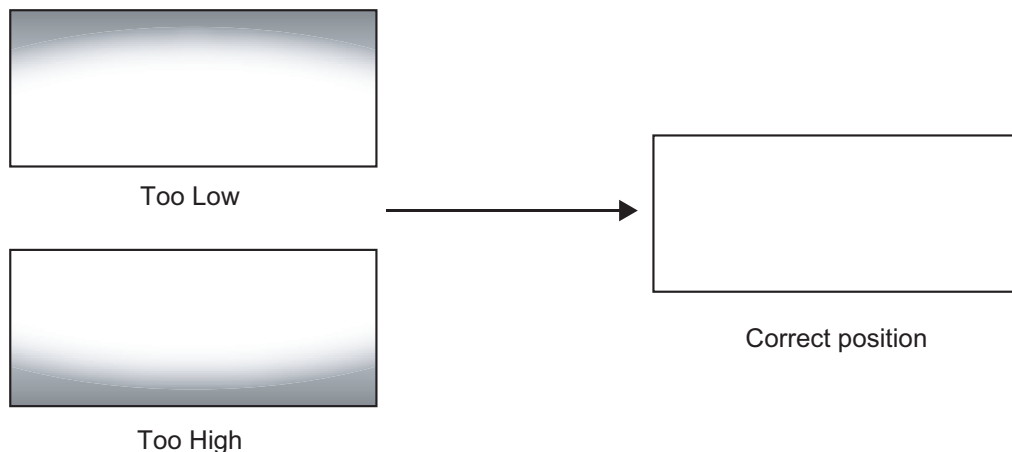

When the height is properly set, tighten the Height Adjustment T-Screws to secure the lens in place.

Adjusting the Pitch (Angle): Next, angle the lens to even out any top-to-bottom pincushion distortion. To do this, loosen the Pitch Adjustment T-Screws (directly below the Height/Y Adjustment T-Screws) on either side of the lens to allow it to pivot freely. Then, adjust the anamorphic lens angle so that the projected image is rectangular:

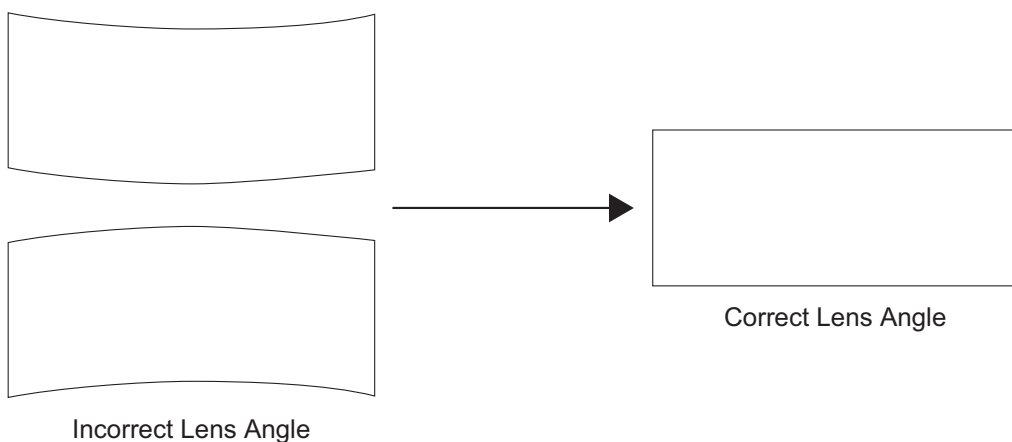

The anamorphic lens will almost always be angled with respect to the projector; this is normal.

Once the proper lens angle has been set, firmly tighten the Pitch Adjustment T-Screws to secure the lens in place.



Note

There may be some pincushion distortion even after the lens is properly adjusted, especially at shorter throw distances. If this is the case, Vidikron recommends that you slightly over-scan the image into the screen frame area to mask the distortion.

Adjusting the Yaw: Loosen the Yaw/X-Adjustment Levers to allow the lens to pivot freely from side to side. Then, angle the lens to even out any left-right pincushion distortion:

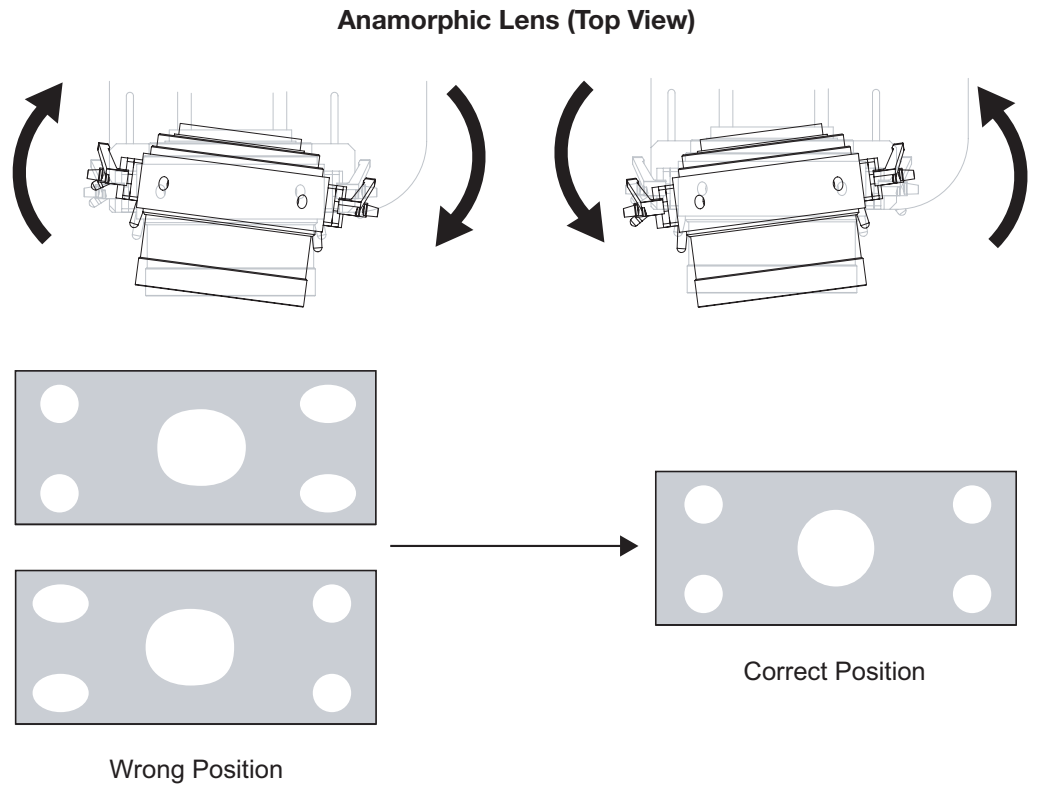

Once the proper lens angle has been set, firmly tighten the Yaw/X-Adjustment Levers to secure the lens in place.

Adjusting the Geometry:

1. Input an anamorphic cross-hatch test pattern to the projector.
2. Unscrew the Anamorphic Lens just enough to allow it to rotate freely.
3. Grasp the lens by the center ring and rotate the lens until the image is properly anamorphic:

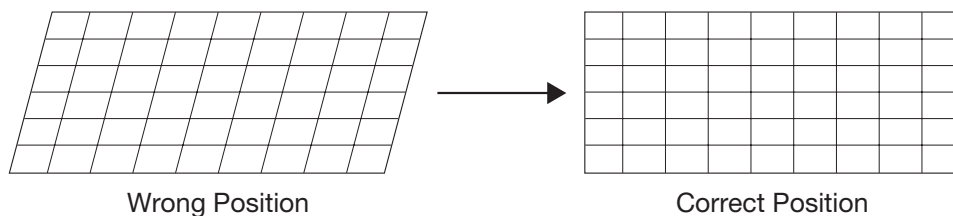

4. When the image geometry appears correct, tighten the Anamorphic Lens Set Screw (item #10) to secure the lens in place. (When viewed from the front, the rear opening on the anamorphic lens should appear as a tall, narrow oval.)



Focus: Finally, rotate the Focus Ring on the anamorphic lens to fine-tune the optical focus.



Notes:

- Press the **MEM1** button on the remote control to recall settings for the current input from the “Custom 1” memory preset.



- Press **ISF NT (Night)** to recall settings for the current input from the “ISF Night” memory preset.
- Press **ISF DAY** to recall settings for the current input from the “ISF Day” memory preset.
- Press **DEF** to recall the factory-default settings for the current input. An on-screen confirmation message appears. Press **DEF** again to confirm.

Use these buttons to select the appropriate aspect ratio for the type of program material being viewed. For more information on aspect ratios, refer to Table 4-1.



When you turn on the Vision 50, it switches to the last selected input and looks for a valid signal.

Use these buttons on the remote control to select an input source directly.



For PIP and PBP purposes, there are two groups of inputs separated by their display modes:

- **Video (SD) group:** Video, S-Video and Component 1 inputs.
- **Graphic (HD) group:** HDMI and Component 2/RGB inputs.

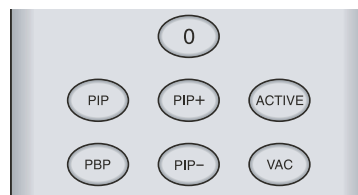

PIP and PBP show one input from the Graphic group within or beside one input from the Video group respectively.

- Press **PBP** to enable the PBP function. Press **PBP** again to switch the screens left to right. Press **PBP** again to turn PBP off.
- Press **ACTIVE** to switch to the active window. (You can only switch inputs in the active window.)
- Press **PIP** to enable the PIP function. Press **PIP** again to switch the main window. Press **PIP** again to turn PIP off.
- To adjust the size of the PIP window, press **PIP+** or **PIP-**.
- Adjust the position of the PIP window with the arrow buttons (▲, ◀, ▼, ▶).

4.1 Selecting Video Memory

4.2 Selecting an Aspect Ratio

4.3 Selecting An Input Source

4.4 Using Picture-In-Picture/ Picture-By-Picture (PIP/PBP)

4.5 Using the On-Screen Menus

- Press the **MENU** button on the remote control to display the Main Menu. To select a menu item, use the UP and DOWN buttons on the remote control to highlight it. Press **ENTER** or **▶** to confirm your selection.
- Use the arrow buttons to select menu items or change settings.
- Press **EXIT** to return to the previous menu.
- Press **MENU** to turn off the OSD menu. (When the Main Menu is displayed, pressing **EXIT** also turns off the menu.)

The Vision 50 OSD menus are arranged hierarchically, as shown in Figure 4-1. Depending on the selected input source and signal characteristics, some menu options may not be available.

Picture Adjust	Brightness	0 ... 60		
	Contrast	0 ... 32		
	Color	0 ... 64		
	Tint	0 ... 30		
	Sharpness	-14 ... 0 ... +25		
	Color Temp.	0, 1 (5400 K), 2 (6500K), 3 (8500 K), 4 or 5 (Custom)		
Color Select	Standard, NTSC, HDTV or PAL			
Image Option	Input Select	Video, S-Video, Component 1, Component 2, RGB-HD or HDMI		
	Aspect Ratio	Anamorphic (16:9)		
		Standard (4:3)		
		Letterbox		
		IntelliWide		
		Cinema		
	SD Enhance	Cinema Fill (Vision 50/CineWide and Vision 50/CineWide with AutoScope only)		
		H Enhance	0, 1, 2, 3 ... 127	
		V Enhance		
		C (Chroma) Enhance		
		H Threshold	10, 11, 12, 13 ... 127	
	V Threshold			
	C (Chroma) Threshold			
	Video Filter	0, 1, 2 or 3		
	HD/RGB Adjust (480p and higher-res. signals only)	Auto Adj.		
		Frequency	0, +1, +2, +3 ... +17	
		Phase	0, +1, +2, +3 ... +31	
		H. Position	-30, -29 ... 0 ... +29, +30	
		V. Position	-28, -27 ... 0 ... +29, +30	
	Blue Enable	On / Off		
Save Settings	Custom 1			
Load Saved Settings	Custom 1, ISF Night or ISF Day			
Projector Status	Default			
	Sleep Timer	0, 10, 20, 30 ... 180 minutes		
	Lamp Power	250W or 200W		
	Lamp Hours	(read-only)		
Installation	Language	English, Français, Español, Deutsch or Italiano		
	Picture Configuration	Floor Front, Floor Rear, Ceiling Front or Ceiling Rear		
	Keystone	-14, -13 ... 0 ... +13, +14		
	OSD Position	Horizontal/Vertical	0/0 (lower left) ... 20/20 (upper right)	
	OSD Timer	0, 3, 6, 9 ... 60 seconds		
	PIP/PBP Setup	PIP Enable	PIP Off	
			Graphic in Video	
		PBP Set Up	Video in Graphic	
			PBP Off	
			Graphic by Video	
	Background Color	Grey, Blue or White		
Service	White Balance	Gain	Red / Green / Blue	
		Offset		
		Gamma		
		Save Color Temp. 4		
		Save Color Temp. 5		
	Gamma Selection	2.8, 2.5, 2.2, 1.0, 2.1, 2.15 or 2.7		
	ICC Adjust	NTSC / HDTV / PAL	R / G / B / Y / C / M Intensity / Sat. / Hue	
	Image Over Scan	Total	0, +1, +2, +3 ... +15	
		Horizontal		
		Vertical		
	Video Black Level	0 IRE or 7.5 IRE		
	Aperture Control	0, 1, 2 ... 19		
	Image Shift	Horizontal	-30, -29, ... 0 ... +29, +30	
		Vertical		
	Amplitude	Horizontal	-60, -59 ... 0 ... +59, +60	
		Vertical		
	Horizontal Masking	0, +1, +2, +3 ... +100	(Vision 50/CineWide and Vision 50/CineWide with AutoScope only)	
	Fan Control	Mode	Auto Normal, Auto Hi. Altitude or Manual	
		Fan Speed (Manual Mode)		
	Lamp Reset Timer	Yes / No		
RS-232 Baud Rate	9600, 38400 or 115200			
Remote Control	Primary			
	Secondary			
Screen Trigger Mode	Normal or Trigger	(Vision 50/CineWide and Vision 50/CineWide with AutoScope only)		
Return to User OSD				
ISF Calibration	Picture Adjust	Brightness, Contrast, Color etc.	(see above)	
	White Balance	Gamma, Gain, Offset etc.	(see above)	
	Gamma Selection	2.8, 2.5, 2.2, 1.0, 2.1, 2.15 or 2.7		
	Aperture Control	0, 1, 2 ... 19		
	Blue Enable	On / Off		
	Save ISF Settings	ISF Night or ISF Day		
	Splash Screen Timer	5, 6, 7 ... 60 seconds		
	ISF Enable	On / Off		
Return to User OSD				







Figure 4-1. Vision 50 OSD Menu Structure

Main Menu ➤ The Main Menu is the starting point for accessing all projector functions.

(The Service and ISF Calibration menus are hidden and not accessible until you enter a passcode.)

Vision Model 50
Picture Adjust
Image Option
Projector Status
Installation
Service
ISF Calibration

Picture Adjust ➤ Select Picture Adjust from the Main Menu to calibrate your Vision 50 for optimum picture quality.

Picture Adjust		
Brightness		30
Contrast		15
Color		31
Tint		15
Sharpness		2
Color Temp.		2
Color Select	NTSC	

To adjust a setting, use the ▲ or ▼ button to highlight it and use the ◀ or ▶ button to change the setting. When finished, press **EXIT**.

The Vision 50 has been designed to incorporate setup and calibration standards established by the Imaging Science Foundation (ISF). The ISF has developed carefully crafted, industry-recognized standards for optimal video performance and has implemented a training program for technicians and installers to use these standards to obtain optimal picture quality from Vidikron video display devices. Accordingly, Vidikron recommends that setup and calibration be performed by an ISF certified installation technician.

All signal types require separate processing. Therefore, you need to calibrate each input separately.



Note

*When you change a picture quality setting, save the change to a preset afterwards. Otherwise, the change will be lost when a different input is selected. (Picture quality settings are saved for each input and resolution separately.) For information about saving settings, refer to **Save Settings** on page 54.*

Although it may be possible to obtain satisfactory picture quality using the naked eye and regular program material, Vidikron recommends using the following calibration tools for best results:

- External test pattern source -- Ovation Multimedia, Digital Video Essentials or AVIA test DVD or equivalent.
- A blue filter (provided with many test DVDs), for color level and tint adjustments.

Connect your test pattern source to the input that you are calibrating and proceed as follows.

Perform the adjustments in the order listed here.

Brightness: On your external test pattern source, select a PLUGE pattern. (PLUGE is an acronym for "Picture Line-Up Generation Equipment.") Figure 4-2 shows a typical PLUGE pattern.

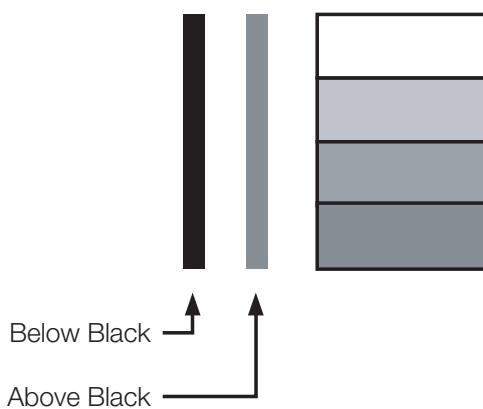

Figure 4-2. Typical PLUGE Pattern for Adjusting Brightness

PLUGE patterns vary but generally consist of some combination of black, white and gray areas against a black background. The example above includes two vertical bars and four shaded boxes.

Select Brightness from the Picture Adjust menu and press **ENTER**. Adjust the brightness so that:

- The darkest black bars disappear into the background.
- The dark gray areas are barely visible.
- The lighter gray areas are clearly visible.
- The white areas are a comfortable level of true white.
- The image contains only black, gray and white (no color).

Contrast: On your external test pattern source, select a stepped, gray-bar pattern like the one shown in Figure 4-3.



Figure 4-3. Typical Gray Bar Pattern for Adjusting Contrast

Select Contrast from the Picture Adjust menu and press **ENTER**. Adjust the contrast to a point just below which the white rectangle starts to increase in size.



Note

Brightness and contrast controls are interactive. A change to one may require a subtle change to the other in order to achieve the optimum setting.

Color Saturation: On your external test pattern source, select a color bar pattern like the one shown in Figure 4-4.

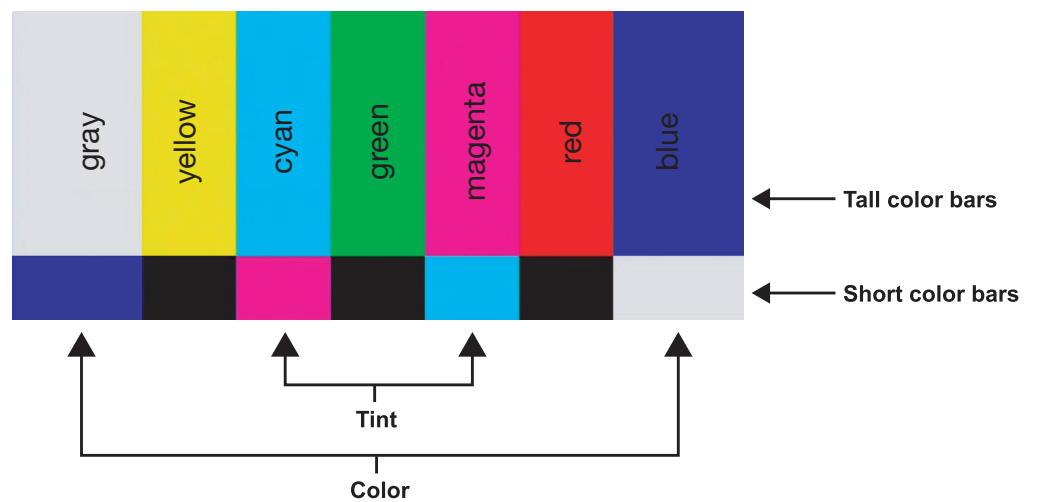
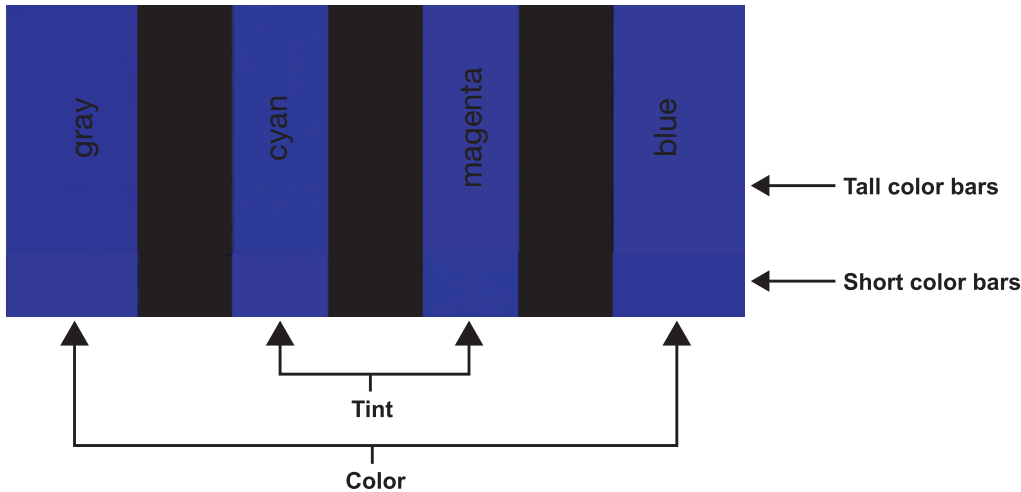

Figure 4-4. Typical Color Bar Pattern for Adjusting Color Saturation and Tint

Select Color from the Picture Adjust menu and press **ENTER**. While looking at the color bar pattern through a blue filter, adjust the color saturation level until the outermost (gray and blue) color bars appear to be a single shade of blue:



Tint: Tint or “hue” is essentially the ratio of red to green in the color portion of the image. When tint is decreased, the image appears redder; when it is increased the image appears greener. To set the tint, select Tint from the Picture Adjust menu and press **ENTER**. While looking at the color bar pattern through a blue filter, adjust the tint level until the cyan and magenta color bars (on either side of the green bar) appear to be a single shade of blue.

**Note**

Like the brightness and contrast controls, the color and tint controls are interactive. A change to one may require a subtle change to the other in order to achieve the optimum setting.

Sharpness: "Sharpness" is the amount of high-frequency detail in the image. To adjust sharpness, select Sharpness from the Picture Adjust menu and press **ENTER**. On your external test pattern source, select a pattern like the one shown in Figure 4-5. Adjust as needed, looking for white edges around the transitions from black to gray and differently-sized lines in the "sweep" patterns at the top and bottom. Lower the Sharpness setting to eliminate them.

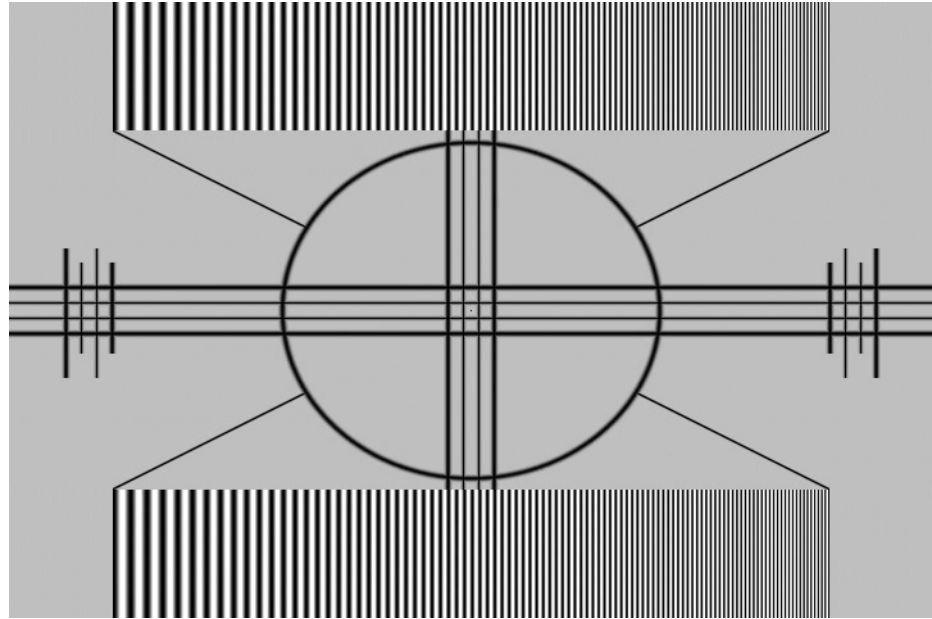

Figure 4-5. Typical Test Pattern for Adjusting Sharpness



Note

The Sharpness setting has no effect if the Video Filter (described on page 54) is set to 0.

Color Temp.: The Vision 50 has six memory settings for Color Temperature. Four of these settings are factory set to default as follows:

- 0 -- Original lamp color temperature
- 1 -- 5400 kelvins
- 2 -- 6500 kelvins
- 3 -- 8500 kelvins
- 4 -- Custom
- 5 -- Custom

Custom 4 and 5 memory are installer-adjustable and can be used to create custom settings. There are nine adjustable "white balance" parameters available for the Custom 4 and 5 settings (three each for red, green and blue). These are described later in this section; refer to **Service** on page 56.



You must enter a passcode in order to enter the Service menu.

Color Select: Use the Color Select menu to select the color space that is appropriate for the source signal, to achieve optimal color balance.

If you select NTSC, HDTV or PAL, you can make further adjustments to individual color space characteristics in the ICC Adjust sub-menu under the ISF Calibration menu, described later in this section. (The Standard color space is factory-set and not adjustable.)

Input Select: To select a source signal, highlight Input Select, press **ENTER** and select Video, S-Video, Component 1, Component 2, RGB-HD or HDMI. Then, press **ENTER** to confirm.

◀ **Image Option**

Image Option
Input Select
Aspect Ratio
SD Enhance
Video Filter
HD/RGB Adjust
Blue Enable
Save Settings
Load Saved Settings

Aspect Ratio: To change the aspect ratio (size and shape) of the projected image, select Aspect Ratio from the Main Menu and press **ENTER**. Select the appropriate aspect ratio for your screen size and the type of program material being viewed; refer to Table 4-1.

Aspect Ratio
Anamorphic (16:9)
Standard (4:3)
Letterbox
IntelliWide
Cinema
Cinema Fill



When you change the aspect ratio, save the change to a preset afterwards. Otherwise, the change will be lost when a different input is selected. (The aspect ratio is saved for each input and resolution separately.)

Table 4-1. Aspect Ratio Settings

Aspect Ratio	Remote Control Key	Description	
Anamorphic	ANA	 <p>16:9 Image on 16:9 Screen (Display)</p> <p>4:3 Image, stretched to fill 16:9 Screen (Display)</p>	<p>Select Anamorphic to view 16:9 DVDs and HDTV programs in their native aspect ratio.</p> <p>4:3 images are stretched horizontally to fit a 16:9 screen.</p>
Standard 4:3	4X3	 <p>4:3 Image on 16:9 Screen (Display)</p>	<p>Standard 4:3 scales the input signal to fit in the center of the 16:9 screen. 4:3 is the aspect ratio used by computer monitors, standard television programming and most VHS video cassettes.</p>
Letterbox	LBOX	 <p>4:3 Image on 16:9 Display (Letterbox aspect ratio)</p>	<p>Letterbox mode scales (zooms in on) a 4:3 image linearly (by the same amount on all sides) to fill a 16:9 display. Letterbox is best suited for viewing LaserDisc movies or non-anamorphic DVDs on a 16:9 screen.</p>
IntelliWide	I-WIDE	 <p>4:3 Image on 16:9 Screen (Display)</p> <p>4:3 Image on 16:9 Screen with IntelliWide</p> <p>4:3 Image on 2.35:1 Screen with IntelliWide</p>	<p>IntelliWide scales a 4:3 image NON-linearly (more on the sides than in the center) to fit a 16:9 screen.</p> <p>On a 2.35:1 screen, the image is centered between black bars on either side.</p>

Table 4-1. Aspect Ratio Settings (continued)

Aspect Ratio	Remote Control Key	Description	
Cinema	CINEMA	 <p>2.35:1 Image on 16:9 Screen (Cinema aspect ratio / no CineWide)</p> <p>2.35:1 Image on 2.35:1 Screen (Cinema aspect ratio / CineWide)</p>	<p>Select Cinema to view 2.35 source material in its native aspect ratio.</p> <p>With a 16:9 screen and a non-CineWide projector (no anamorphic lens), the upper and lower portions of the screen are masked, but the geometry of the active image area is unchanged.</p> <p>With a 2.35:1 screen and a CineWide-equipped projector, the projector scales the 2.35:1 image so that the active image area fills the 16:9 chip surface, eliminating the black bars. The secondary, anamorphic lens then restores the proper geometry to the 2.35:1 image.</p>
Cinema Fill	C-FILL	 <p>16:9 Image on 2.35:1 Screen</p> <p>16:9 Image on 2.35:1 Screen with Cinema Fill</p>	<p>A 16:9 image is scaled NON-linearly (more on the sides than in the center) to fit a 2.35:1 screen.</p> <p>Cinema Fill is available only on the Vision 50/CineWide and Vision 50/CineWide with AutoScope.</p>

SD Enhance: The SD Enhance menu gives you options for improving the quality of standard-definition, 480i images. (For 480p and higher-definition images, the controls in this menu are disabled.) Keep in mind that these controls add frequencies that are not present in the original signal, and may make images appear “noisy” if misused.

- **H Enhance/V Enhance:** These controls can improve the apparent horizontal and/or vertical resolution of the image.
- **Chroma Enhance:** This control adds chroma (color information) to the input signal and can make colors appear more vibrant and saturated.
- **H Threshold/V Threshold/Chroma Threshold:** Set these to +11 or higher to activate the enhancement controls described above. Generally, the higher the threshold, the more noticeable the enhancements you make will be.

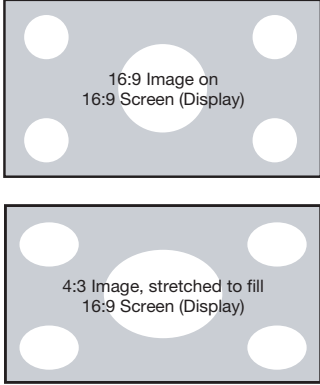
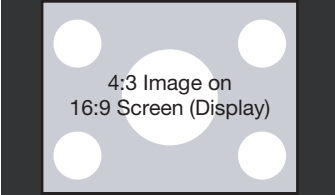
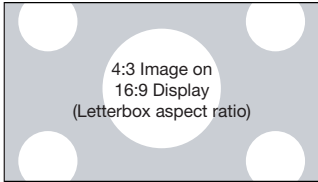
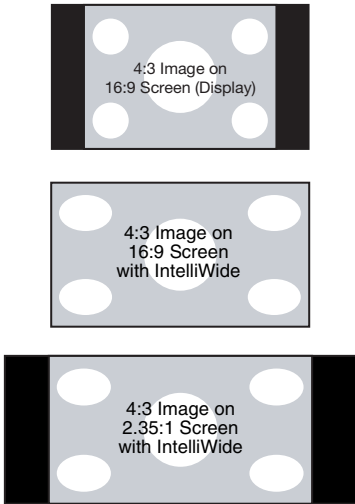
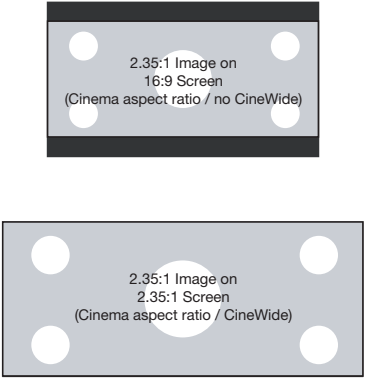
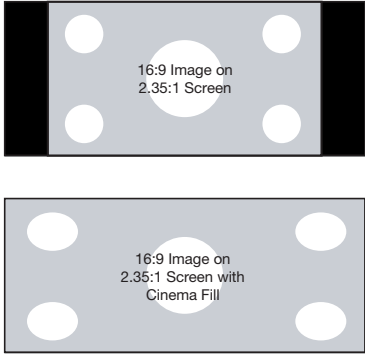
Video Filter: The Video Filter setting controls the behavior of the Sharpness control. The available settings depend on the vertical resolution of the input signal, as follows:

- **With a 480i signal**, you can apply the sharpness control to either the input signal (1), the output signal (2), both (3) or neither (0).
- **With a 480p or higher-resolution signal**, the sharpness control is applied only to the output signal and only when you set the Video Filter to “on” (1).

HD/RGB Adjust: Use the settings in the HD/RGB Adjust menu to fine-tune 480p and higher-resolution signals for optimum picture quality.

- **Auto:** Adjusts the phase, frequency and position automatically.
- **Freq.** Adjusts the frequency of the signal.
- **Phase:** Adjust the phase if the image (usually from an RGB source) shows shimmer or “noise.” Pixel phase adjusts the phase of the pixel sampling clock relative to the incoming signal. The effect of this control is similar to that of a tracking control on a VCR.

For best results, use a good test pattern such as a smooth gray consisting of a clear pattern of black and white pixels, or a similar “half on, half off” graphic image. (You may find that you can stabilize the image at more than one point. Use either setting in this case.)

- **H. Pos.:** Adjusts the horizontal position of the image.
- **V. Pos.:** Adjusts the vertical position of the image.



Note

To adjust the image position with a 480i source, use the Image Shift controls in the Service menu (see page 57).

Blue Enable: Press the ▲ or ▼ button to turn the Blue Enable Off or On. This feature removes all red and green color information from the image (simulating a blue filter), and is useful for color-calibrating the projector or other video components.

Save Settings: When you have finished making your adjustments, select Save Settings to store the settings for the current input in the “Custom 1” memory location.

Load Saved Settings: To recall stored custom image quality settings, select Load Saved Settings and choose “Custom 1,” “ISF Night” or “ISF Day.”

Projector Status ➤

Projector Status	
Default	Load
Sleep Timer	30 Minutes
Lamp Power	200 W
Lamp Hours	+8 Hours
	0 Minutes

To load default settings, configure the sleep timer or adjust the lamp, select Projector Status from the Main Menu and press **ENTER**.

Default: To restore the default image settings for the current input source ONLY, press the ▲ or ▼ button to highlight “Load,” then press **ENTER**.

Sleep Timer: The Sleep Timer automatically puts the projector into standby mode after the amount of time you specify here. (A warning appears on-screen one minute before this is to occur.)

Use the ◀ or ▶ button to set the timer for anywhere from 10 to 180 minutes (three hours), in 10-minute increments. To disable the Sleep Timer, set it to 0.

Lamp Power: Select Lamp Power from the Projector Status Menu to adjust the lamp output level. You can choose to run the lamp as bright as possible (250W; this is the default setting) or you can choose the lower (200W) setting. Generally, lower lamp output can prolong the life of the lamp, but decreases brightness.

Lamp Hours: Lamp Hours indicates how long the currently-installed lamp has been in service. (This part of the menu is read-only.)

To access the Installation adjustments, press **MENU**, then press the ▲ or ▼ button to highlight Installation and press **ENTER**. The Installation sub-menu, shown at left, appears. Press **EXIT** to return to the previous menu or press **MENU** to close all menus.



Note

*When you change a setting in the Installation menu, the change takes effect immediately; you do not need to press **ENTER** afterwards. (Press **EXIT** to return to the previous menu or **MENU** to exit.)*

Language: Press the ▲ or ▼ button to select from the available languages (English, French, Spanish, German and Italian).

Picture Configuration: Press the ▲ or ▼ button to change the orientation of the projected image. The Vision 50 can be installed on a ceiling or in a rear-screen configuration with one or more mirrors. There are four settings: Floor Front, Ceiling Front, Floor Rear and Ceiling Rear.

Keystone: To correct distortion resulting from the angle of projection, select Keystone and use the ◀ or ▶ button to make the image rectangular.



Tip

Vidikron recommends that the keystone feature not be used unless absolutely necessary, as it may cause artifacts in the image.

OSD Position: To adjust the horizontal and vertical position of the OSD, select OSD Position and press **ENTER**. Then, press the ▲ or ▼ button to select Horizontal or Vertical and use the ◀ or ▶ button to adjust.

OSD Timer: Use the ◀ or ▶ button to set the OSD Timer. This timer controls how long the menus remain on-screen after selecting them. Select from 0 to 60 seconds, in 3-second increments. When you set the OSD Timer to 0, the menus remain on-screen until you hide them by pressing **MENU**.

PIP/PBP Setup: Select PIP/PBP Setup from the Installation menu to change the PIP/PBP settings.

- **PIP/PBP Enable:** Press the ▲ or ▼ button to select PIP/PBP Enable, then press **ENTER**. Press the ▲ or ▼ button to select Off or On, then press **ENTER**.
- **PIP Set Up:** Press the ▲ or ▼ button to select PIP Set Up, then press **ENTER**. Press the ▲ or ▼ button to select PIP Off, Graphic in Video or Video in Graphic, then press **ENTER**.
- **PBP Set Up:** Press the ▲ or ▼ button arrows to select PBP Set Up, then press **ENTER**. Press the ▲ or ▼ button to select PBP Off, Graphic by Video or Video by Graphic, then press **ENTER**.

Background Color: Press the ▲ or ▼ button to select the image Background Color (grey, blue or white). The Background Color appears when no incoming signal is present.

◀ Installation

Installation
Language
Picture Configuration
Keystone
OSD Position
OSD Timer
PIP/PBP Setup
Background Color

Service ➤

Service
White Balance
Gamma Selection
ICC Adjust
Image Over Scan
Video Black Level
Aperture Control
Image Shift
Amplitude
Horizontal Masking
Fan Control
Lamp Reset Timer
RS-232 Baud Rate
Remote Control
Screen Trigger Mode
Return to User OSD

To access advanced projector settings, use the up- or down-arrow keys to select Service from the Main Menu and press **ENTER**. Use the number buttons on the remote to enter the Service menu passcode when prompted and press **ENTER** again. Then, press **MENU** on the remote control.



Note

You only need to enter the Service menu passcode the first time you select that menu after turning on the projector.

White Balance: To remove any trace of color from the white areas of the projected image, choose White Balance from the Service menu and press **ENTER**.

- **Gamma:** “Gamma” is a global setting that determines how gray shades are displayed between minimum input (black) and maximum input (white) for all signals. A good gamma setting helps to optimize blacks and whites while ensuring smooth transitions for the “in-between” values utilized in other grays. Unlike “Brightness” and “Contrast” controls, the overall tone of your images can be lightened or darkened without changing the extremes and all images will be more vibrant while still showing good detail in dark areas.

In all but the most unusual situations, the appropriate “Gamma Selection” (see below) will produce accurate colors and a satisfying contrast level. However, it is sometimes necessary to adjust the red, blue and green gamma curves individually. To do this, select Gamma from the White Balance sub-menu and use the left- and right-arrow buttons to manipulate the on-screen slidebars.

- **Gain:** Use the Gain controls to correct color imbalances in the bright areas of the image. A good way to do this is to use a test pattern consisting mostly of solid white areas, such as an 80 IRE “window” pattern. If the white areas contain traces of red, green or blue, decrease the Gain for that color.
- **Offset:** Use the Offset controls in the White Balance sub-menu to correct color imbalances in the dark areas of the image. A good way to do this is to use a test pattern consisting mostly of dark gray areas, such as a 30 IRE “window” pattern. If the gray areas contain traces of red, green or blue, decrease the Offset for that color.
- **Store Color Temp.4/Store Color Temp.5:** When you are finished adjusting the Gamma, Gain and Offset, select Store Color Temp.4 or Store Color Temp.5 to store your settings. To recall them, set the Color Temperature to +4 or +5 in the Image Adjustment menu (refer to **Picture Adjust** on page 46).

Gamma Selection: The normal gamma setting of 2.2 is correct for almost all signals and conditions. If excess ambient light washes out the image and it becomes difficult or impossible to see details in dark areas, lower the gamma setting to compensate. This will improve contrast while maintaining good details for blacks. Conversely, if the image is washed out and unnatural, with excessive detail in black areas, increase the setting. Again, good gamma improves contrast while maintaining good details for blacks and whites.

ICC Adjust: Use the ICC Adjust controls to customize the stored NTSC, HDTV and/or PAL color space characteristics. To do this, select the color space to modify. Then, select a component color (Red, Green, Blue, Yellow, Cyan or Magenta).

For each component color, you can adjust the following:

- **Intensity:** This slider adjusts the intensity – also known as *luminance* – of a given color.
- **Sat.** This slider adjusts the color saturation level – the amount of that color in a video image. Lower settings produce less saturated colors; a setting of “0” removes that color from the image entirely. If the saturation is too high, that color will be overpowering and unrealistic.
- **Hue:** This slider adjusts the red/green color hue for true color reproduction of video signals. For best results, adjust tint while displaying an external color bars test pattern (see Figure 4-4). Otherwise, it is recommended that Hue remain at its default setting.

When you have finished customizing the color space, select Store Setting and press **ENTER**.

Image Over Scan: Image Over Scan pushes the outside edge of the active picture area of the video signal out beyond the edge of the display area.

Some television programs are produced based on the assumption that older television sets may not display the outer edges of the broadcast picture area. Over scan effectively trims away these inactive, outer edges and enlarges the remaining portion of the image to fill the display area.

Use the on-screen slider to select the desired amount of over scan.

For HDTV, DVDs and other video sources, Image Over Scan is generally not necessary or desirable.

Video Black Level: This control compensates for incoming elevated black levels present in certain video signals, and ensures that blacks in the display are neither “crushed” (where dark grays appear black) nor excessively elevated (where blacks appear dark gray). By default, the projector automatically determines the best setting according to the type of incoming video signal:

- **0 IRE:** Used for DVD output with “enhanced black,” SECAM, most PAL standards and Japanese NTSC.
- **7.5 IRE:** Used for most NTSC video signals.

For some types of video, you may want to override the setting. Generally, if black appears crushed when brightness = 30, choose “0 IRE.” If black appears excessively elevated, use “7.5 IRE.”

Aperture Control: Use the Aperture Control to increase or decrease the aperture or iris size (the physical opening through the lens; similar to an “f-stop” on a camera). Doing so allows you to optimize brightness and contrast according to the amount of ambient light in the viewing area.

Use a higher setting for rooms with lots of ambient light. Use a lower setting for more “theater-like” viewing conditions (little or no ambient light).

Image Shift: The Image Shift menu allows you to precisely center the image on the screen. (These controls are available only with a 480i source signal.)

- **Horizontal:** This control moves the image right or left within the area of available pixels.
- **Vertical:** This option moves the image up or down within the area of available pixels.



Note

1. To adjust the image position with a 480p or higher-resolution source, use the HD/RGB Adjust controls in the Option menu, described on page 54.
2. The values shown represent where the approximate center of the image lies in relation to the total number of pixels available horizontally or vertically. This varies widely according to the signal; watch the image while adjusting.

Amplitude: The Amplitude menu allows you to fine-tune the currently-selected image aspect ratio by stretching it horizontally or vertically, in small increments. This can be useful if your projector is equipped with an anamorphic lens.

The Horizontal control adjusts the image width while keeping the height constant. Similarly, the Vertical control adjusts the image height while keeping the width constant.

Horizontal Masking (Vision 50/CineWide and Vision 50/CineWide with AutoScope only): To achieve the proper image geometry with the secondary anamorphic lens, select Horizontal Masking from the Service menu. Then, use the ◀ or ▶ button to change the native aspect ratio of the display, in small increments.

Fan Control: Select Fan Control from the Service Menu to control the operation of the projector's cooling fan.

- **Mode:** In most cases, the default Fan Control Mode (Auto Normal) will maintain the correct operating temperature. If the lamp frequently turns off due to overheating, or in certain high-altitude operating environments, you may need to change this setting to Auto Hi. Altitude or Manual.
- **Fan Speed:** If you set the Fan Mode to Manual, select Fan Speed and use the on-screen slider to adjust the speed.

After changing either of these settings, press **EXIT** to return to the previous menu.

Lamp Reset Timer: When you replace the projector lamp (refer to **Lamp Replacement** on page 63), you should also reset the lamp timer. To do this, select Lamp Reset Timer from the Service menu. Press the right-arrow key on the remote to highlight "Yes," then press **ENTER** to confirm the reset.



Note

Reset the Lamp Timer ONLY after you replace the lamp. Otherwise, the reported "Lamp Hours" will be inaccurate.



WARNING

Do not exceed the recommended lamp life of 2000 hours. An old lamp becomes increasingly fragile and prone to sudden failure.

RS-232 Baud Rate: To change the data rate of the projector's RS-232 input, select RS-232 Baud Rate from the Service menu. Set it to either 9600, 38400 or 115200, to match the data rate of the computer or control system connected to the projector.

Remote Control: The Remote Control menu shows you the primary and secondary infrared (IR) codes to which the Vision 50 will respond. The Primary IR code is permanently set to +20. The secondary IR code is also +20.

You can change the secondary IR code if either:

- Another device in the theater (a DVD player, for example) is responding to commands from the Vision 50 remote control in ways that are unpredictable or undesirable.
- You have multiple Vision 50 projectors and want to control them independently, as opposed to broadcasting commands from a single remote to all of them. In this scenario, you can use multiple remotes programmed to use different IR codes. Or, you can use a single remote and change the IR code as needed to address a specific projector.

When you change the secondary IR code, the remote sends that code instead of the primary IR code.



Note

The Remote Control menu is read-only and need not be visible in order to change the secondary IR code.

To simultaneously change the secondary IR code and synchronize that remote with a projector, *point the remote at the projector*, then press and hold ◀ and ▶ simultaneously for five seconds. The Remote Control edit window, shown at left, appears. Type a new, two-digit code.

Remote Control	
Secondary	20

The procedure for changing the secondary IR code on the remote *only* is the same, except that you point the remote away from the projector.

Screen Trigger Mode (Vision 50/CineWide with AutoScope only): Select Screen Trigger Mode from the Service menu to set the behavior of the 12-volt trigger output.

- Set the Screen Trigger Mode to Normal if you want the trigger to activate when the projector is turned on (for instance, if the trigger is controlling a retractable screen).
- Set the Screen Trigger Mode to Trigger if you want the trigger to activate when the Cinema or Cinema Fill aspect ratio is selected.

Return to User OSD: To exit the Service menu, use the up- or down-arrow keys to highlight Return to User OSD and press **ENTER**.

To return to the Service menu, select it from the Main Menu, press **ENTER** twice, then press **MENU** on the remote control. (You do not need to re-enter the passcode.)

ISF Calibration ➤

ISF Calibration
Picture Adjust
White Balance
Gamma Selection
Aperture Control
Blue Enable
Save ISF Settings
Splash Screen Timer
ISF Enable
Return to User OSD

To access the ISF Calibration menu, select ISF Calibration from the Main Menu and press **ENTER**. Use the number buttons on the remote control to enter the ISF Calibration menu passcode when prompted and press **ENTER** again. Then, press **MENU** on the remote control.

**Note**

This menu should be used by ISF-certified technicians only.

Picture Adjust: These settings are described in the **Picture Adjust** section (page 46).

White Balance / Gamma Selection / Aperture Control: These settings are described in the previous section, **Service**.

Blue Enable: This setting is described in the **Image Option** section (refer to page 54).

Save ISF Settings: For each input, the Vision 50 lets you store image quality settings as presets that you can recall at a later time. You can create up to three presets per input and resolution.

**Note**

When you change a setting, save the change to a preset afterwards. Otherwise, the change will be lost when a different input is selected. (Most settings are saved for each input and resolution separately.)

To store image quality settings to a preset:

1. Select Picture Adjust from the ISF Calibration menu.
2. Select Color Temp. from the Picture Adjust menu.
3. Use the ◀ or ▶ button to set the color temperature to "4" or "5." **Make a note of your selection.**
4. Press **EXIT**.
5. Adjust brightness and contrast as described in the **Picture Adjust** section (page 46). Exit the Picture Adjust menu when finished.
6. Select White Balance from the ISF Calibration menu. Adjust the grayscale as required (refer to **White Balance** on page 56).
7. From the White Balance menu, select "Save Color Temp. 4" or "Save Color Temp. 5" (depending on your selection in Step 3) and press **ENTER**.
8. From the ISF Calibration menu, select Save ISF Settings and choose "Save ISF Night" to store your settings.
9. Repeat Steps 1 through 8 for the "ISF Day" preset.

**Tip**

The first time you perform this procedure, store the current white balance settings in both color temperatures (4 and 5). This will give you a convenient starting point for color temperature 5, should you wish to use it for the other preset.

To recall stored custom image quality settings, select Load Saved Settings from the Image Option menu (refer to **Image Option** on page 51) and choose "Custom 1," "ISF Night" or "ISF Day." Or, simply use the corresponding buttons on the remote control.

Splash Screen Timer: Use the ◀ or ▶ button to set the Splash Screen Timer. This timer controls how long the startup (ISF and Vidikron logo) image stays on-screen after you turn on the projector. Select from 5 to 60 seconds, in one-second increments. When finished, press **EXIT**.

ISF Enable: Select ISF Enable from the ISF Calibration menu to control the display of the ISF logo on the Vision 50 splash screen upon power-up.

You can personalize the Vision 50 splash screen with the projector owner's name and/or the installer's name. For instructions, refer to Appendix A.

Return to User OSD: To exit the ISF Calibration menu, use the up- or down-arrow keys to highlight Return to User OSD and press **ENTER**.

To return to the ISF Calibration menu, select it from the Main Menu, press **ENTER** twice, then press **MENU** on the remote control. (You do not need to re-enter the passcode.)

Notes:

Maintenance and Troubleshooting

The lamp should be replaced when it reaches the end of its life (typically 2000 hours), or sooner if a noticeable degradation in brightness occurs. Contact your Vidikron dealer to obtain a replacement lamp.

5.1 Lamp Replacement

1. Turn off the projector and unplug the power cord.
Allow the projector to cool down for approximately 45 minutes prior to removing the lamp assembly for replacement.
2. Remove the three screws from the lamp cover.
3. Remove the lamp cover.
4. Remove the two lamp assembly mounting screws.
5. Grasp the lamp assembly handle and pull gently, removing the lamp module from the projector housing.
6. Install the new lamp module and replace the two screws.
7. Replace the lamp cover at the top first and secure it with the three screws.
8. Turn on the power and select Lamp Reset Timer from the Service menu to reset the lamp timer (refer to **Lamp Reset Timer** on page 58).

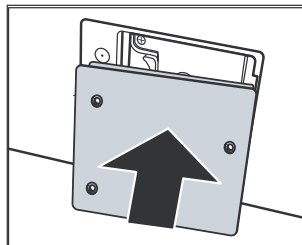
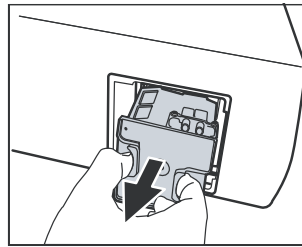
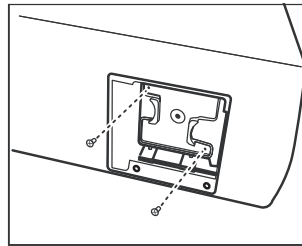
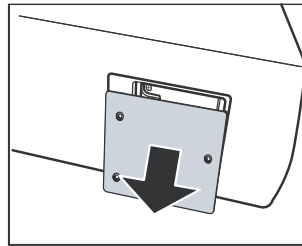
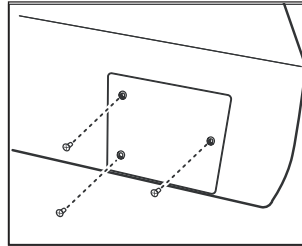

5.2 Troubleshooting Tips

Table 5-1 provides some general guidelines for troubleshooting problems you may encounter with the Vision 50. If the suggested solutions fail to resolve the problem or if you encounter an issue not described here, please contact Vidikron Technical Support.

Table 5-1. Troubleshooting Chart

Symptom	Possible Cause(s)	Solution
The projector does not turn on.	<ul style="list-style-type: none"> The Vision 50 is not plugged in or the AC outlet is not active. The main power switch (at the rear of the projector) is off. Lamp cover is not securely attached. 	<ul style="list-style-type: none"> Ensure that the Vision 50 is plugged in and that the AC outlet is active. Turn on the power switch. Securely attach the lamp cover.
The projector does not turn back on after it was powered off.	<ul style="list-style-type: none"> The projector will not turn on for two minutes after power-off, to protect the lamp. 	<ul style="list-style-type: none"> Wait until the Vision 50 completes its cool-down (POWER LED lights solid orange).
The remote control does not work correctly.	<ul style="list-style-type: none"> The batteries have run out. 	<ul style="list-style-type: none"> Replace the batteries.
The projector is on and OSD menus appear, but there is no video image on-screen.	<ul style="list-style-type: none"> Incorrect source selection. Source component is not turned on. Source component is connected incorrectly or not at all. 	<ul style="list-style-type: none"> Select the correct source. Turn on the source. Check cable connection from source component to projector.
A projected image from a DVD is split or otherwise scrambled.	<ul style="list-style-type: none"> DVD player is connected to the Component input and set to progressive scan mode. 	<ul style="list-style-type: none"> Turn off progressive scan on the DVD player.
Image is blurred.	<ul style="list-style-type: none"> The lens is not correctly focused. 	<ul style="list-style-type: none"> Adjust the focus with the remote control.
Image is too bright and/or lacks definition in the bright areas of the image.	<ul style="list-style-type: none"> Contrast is set too high. 	<ul style="list-style-type: none"> Lower the contrast setting.
Image appears "washed out" and/or dark areas appear too bright.	<ul style="list-style-type: none"> Brightness is set too high. 	<ul style="list-style-type: none"> Lower the brightness setting.
Colors in the image are swapped; for example, reds appear blue or vice versa.	<ul style="list-style-type: none"> The Red/Pr, Green/Y or Blue/Pb outputs from the source are connected to the wrong inputs on the Vision 50. 	<ul style="list-style-type: none"> Ensure that the source outputs are connected to the correct Vision 50 input.

Table 5-1. Troubleshooting Chart (continued)

Symptom	Possible Cause(s)	Solution
TEMP and LAMP LEDs are both flashing red.	<ul style="list-style-type: none"> The lamp cover is open. Fans are not working properly. 	<ul style="list-style-type: none"> Close the lamp cover. Please contact your Vidikron dealer for assistance.
LAMP LED lights solid red.	<ul style="list-style-type: none"> The lamp has failed or exceeded its usage life. 	<ul style="list-style-type: none"> Replace the lamp with a new one.
TEMP LED lights solid red.	<ul style="list-style-type: none"> Vision 50 internal temperature is too high. 	<ul style="list-style-type: none"> Power off the Vision 50 and allow it to cool down. Ensure that the intake and exhaust vents are not blocked. Turn the projector back on. If the problem persists, please contact your Vidikron dealer for assistance.

Notes:

Serial Communications

To interface the Vision 50 with a home theater automation/control system or a PC running terminal emulation software:

1. Connect it to your control system or PC as shown in Figure 3-13.
2. Start a terminal session on your PC using a terminal-emulation program, such as HyperTerminal.
3. Configure the RS-232 controller or PC serial port as follows: no parity, 8 data bits, 1 stop bit and no flow control. Set the baud rate to match that of the projector (115200, 38400 or 9600).
4. Press **<Enter>**. You should see a command prompt (>) in the terminal window.
5. Type a command from among those listed in Table 6-1 and press **<Enter>**. For example, to change the aspect ratio to Letterbox, type `x063x` **<Enter>**.

Serial commands to the Vision 50 take the following form:

- Commands are in ASCII format.
- Commands are not case-sensitive; `X001X` and `x001x` are equivalent.
- A carriage return MUST follow each command.



Note

The Vision 50 will not accept serial commands for 20 seconds after it is turned on or off.

Table 6-1. Serial Commands

Code	Function
x001x	Power On
x002x	Power Off
x003x	Menu
x004x	Enter
x005x	Exit
x006x	Up (arrow key)
x007x	Down (arrow key)
x008x	Left (arrow key)
x009x	Right (arrow key)
x011x	Show active source and aspect ratio information
x021x	Keypad 1
x022x	Keypad 2

6.1 RS-232 Connection and Port Configuration

6.2 Serial Command Syntax

Table 6-1. Serial Commands (continued)

Code	Function
x023x	Keypad 3
x024x	Keypad 4
x025x	Keypad 5
x026x	Keypad 6
x027x	Keypad 7
x028x	Keypad 8
x029x	Keypad 9
x030x	Keypad 0
x031x	Store image settings to Custom 1
x032x	Store image settings to ISF Night
x033x	Store image settings to ISF Day
x046x	Restore image settings from Custom 1
x047x	Restore image settings from ISF Night
x048x	Restore image settings from ISF Day
x049x	Load default of current source
x051x	Single source, full-screen
x052x	PIP - graphics on video
x053x	PIP - video on graphics
x054x	PBP - graphics by video
x055x	PBP - video by graphics
x056x	PIP - increase sub-window size
x057x	PIP - decrease sub-window size
x058x	Set PIP/PBP active window
x061x	Anamorphic (16:9) aspect ratio
x062x	Standard (4:3) aspect ratio
x063x	Letterbox aspect ratio
x064x	IntelliWide aspect ratio
x065x	Cinema aspect ratio
x066x	Cinema Fill aspect ratio
x071x	RS-232 baud rate = 9600
x072x	RS-232 baud rate = 38400
x073x	RS-232 baud rate = 115200

Table 6-1. Serial Commands (continued)

Code	Function
x081x	Image orientation = floor front
x082x	Image orientation = ceiling front
x083x	Image orientation = floor rear
x084x	Image orientation = ceiling rear
x091x	Lamp Power = 200W
x092x	Lamp Power = 250W
x121x	OSD Language = English
x122x	OSD Language = French
x123x	OSD Language = Spanish
x124x	OSD Language = German
x125x	OSD Language = Italian
x131x	Switch to Composite input
x132x	Switch to S-Video input
x133x	Switch to RGB-HD input
x134x	Switch to DVI input (HDMI)
x135x	Switch to Component 1 input
x136x	Switch to Component 2 input
x156x	Background Color = Grey
x157x	Background Color = Blue
x158x	Background Color = White
x161x	Un-freeze Image
x162x	Freeze Image
x181x	Toggle Blue Image on/off
x261x	Vertical Lens Shift = Up (incremental)
x262x	Vertical Lens Shift = Down (incremental)
x263x	Zoom Out (incremental)
x264x	Zoom In (incremental)
x265x	Focus (rotate lens to right)
x266x	Focus (rotate lens to left)
x267x	Aperture Control = +1 (larger aperture)
x268x	Aperture Control = -1 (smaller aperture)
x281x	Vertical Lens Shift = Max. Up

Table 6-1. Serial Commands (continued)

Code	Function
x282x	Vertical Lens Shift = Max. Down
x283x	Zoom = Max. Out
x284x	Zoom = Max. In
x285x	Focus (rotate lens to right, full-range)
x286x	Focus (rotate lens to left, full-range)
x287x	Aperture Control = Full On (open)
x288x	Aperture Control = Full Off (closed)

Specifications

Table 7-1 lists the Vision 50 specifications.

Table 7-1. Vision 50 Specifications

Projector Type:	Digital Light Processing (DLP), Single-Chip DMD
Native Resolution:	1280 x 720 (16:9)
Aspect Ratios:	4:3, Letterbox, 16:9 Anamorphic, IntelliWide, Cinema, Cinema Fill
Video Standards:	NTSC, PAL, SECAM
DTV Compatibility:	480p, 576p, 720p, 1080i
Scan Frequency:	Horizontal: 15 - 80 kHz Vertical: 50 - 100 Hz
Picture Size (16:9 Screen):	Recommended Width: 72 in. (1.83 m) to 96 in. (2.44 m) Capable of screen widths between 48 in. (1.22 m) and 200 in. (5.08 m)
Throw Distance (Factor x Screen Width):	Refer to Table 3-3
Horizontal and Vertical Lens Shift:	Horizontal: None Vertical: 50% of screen height above or below lens center

7.1 Vision 50 Specifications

Table 7-1. Vision 50 Specifications (continued)**Brightness and Contrast:****Cinema Standards Measurement System (CSMS) Specifications**

- Brightness*: 14.7 to 21.5 foot-Lamberts (fL)
- Contrast Ratio*: 195:1 to 218:1

*Variable depending on Aperture Control setting

These measurements are taken from the projector in a controlled, home theater environment. All measurements are made to ANSI/NAPM IT7.228-1997 specifications using the Photo Research PR-650 SpectraColorimeter and Minolta LS-100 Luminance Meter, Video Essentials test DVD and a 1.3 gain, 72-inch wide screen. The projector is calibrated to a color temperature of 6,500K and has a minimum of 150 hours of usage.

The foot-Lambert (fL) is the unit of measurement used in commercial movie theaters to express image brightness at the screen surface. The Society of Motion Picture and Television Engineers (SMPTE) specifies 16 fL as the target image brightness for film-based projectors using an open gate (without film in the projector). More importantly, today SMPTE specifies 12 fL as the target image brightness in Digital Cinema theaters. The foot-Lambert measurement is dependent on screen size, screen gain and projector light output.

Home Theater Calibration Specifications

- Light Output: 449 to 585 ANSI Lumens
- Contrast Ratio*: 195:1 to 218:1

These specifications are obtained by calibrating the projector as described above for CSMS measurements.

Industry-Standard Specifications

- Light Output: 1225 ANSI Lumens
- Contrast Ratio: 1400:1 to 3000:1

These are typical projector brightness and contrast specifications found in most companies' sales literature. Vidikron includes these measurements in its literature to allow for direct comparison with other manufacturers' projectors. These measurements are typically taken at 9,000K to 13,000K to get expected performance data when the projector is used in professional, commercial and industrial displays.

Lamp:	250 Watts
Estimated Lamp Life:	2000 hours
Video Inputs:	(1) Composite Video, (1) S-Video, (1) RGB/Component Video (BNC connectors), (1) RCA Component Video, (1) HDMI
Control Options:	<ul style="list-style-type: none"> - Discrete IR remote - Built-in keypad - Serial commands via RS-232
RS-232 Communication Parameters:	9600, 38400 or 115200 bps, no parity, 8 data bits, 1 stop bit, no flow control
12V Output:	Max. 0.25 Amps, active when Cinema or Cinema Fill Aspect Ratio is selected (Vision 50/CineWide with AutoScope only) or when projector is turned on; Tip = +12V; Sleeve = Ground
Power Requirements:	100 to 240 VAC (auto-sensing), 50/60 Hz, 330 Watts
Operating Environment:	41°F to 95°F (5°C to 35°C), 20% to 80% humidity (non-condensing)
Dimensions:	See Figure 7-1
Weight (without lens):	46.5 lbs. (21.09 kg)

Table 7-1. Vision 50 Specifications (continued)

Regulatory Approvals:	Complies with FCC, CE C-Tick
Limited Warranty:	Projector: Two (2) years parts and labor from the date of delivery to the end user. Lamp: 1000 hours or six (6) months, whichever comes first.
Specifications are subject to change without notice.	

7.2 Vision 50 Dimensions

Figure 7-1 shows the Vision 50 dimensions.

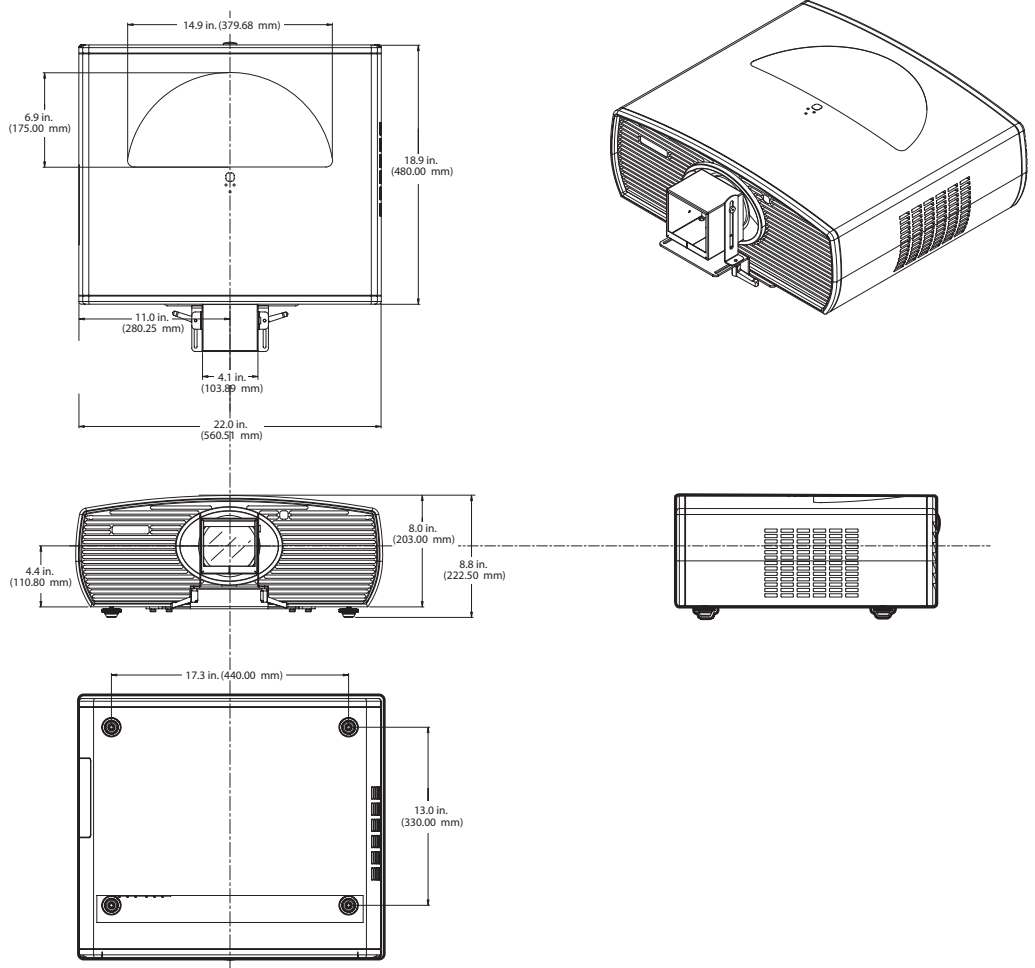

Figure 7-1. Vision 50 Dimensions (with Optional Fixed Anamorphic Lens)

Appendix A. Personalizing the ISF Splash Screen on the Vision 50

This Appendix describes how to personalize the ISF splash screen on the Vidikron Vision 50 Series DLP Projectors.



Note

Only ISF-trained and -certified technicians should attempt this procedure!

1. Connect a PC to the Vision 50 RS-232 port and establish a serial connection; refer to **RS-232 Connection and Port Configuration** on page 67 if you need instructions.
2. Press **MENU** on the projector remote control. Use the up- or down-arrow keys to highlight **ISF Calibration** and press **ENTER**. Use the number buttons on the remote control to enter the ISF Calibration menu passcode, then press **ENTER** again.
3. Press **MENU** on the projector remote control. Then, select **Splash Screen Timer** from the ISF Calibration menu.
4. Use the left- or right-arrow buttons to set the Splash Screen Timer. This timer controls how long the startup (Vidikron/ISF logo) image stays on-screen after you turn on the projector. The range is from 5 to 60 seconds in 1-second increments. For this procedure, set it to 30 seconds and press **EXIT**.
5. In the HyperTerminal window, at the command prompt (>), type U1 followed by the customer name, four or five spaces and the ISF calibrator name:

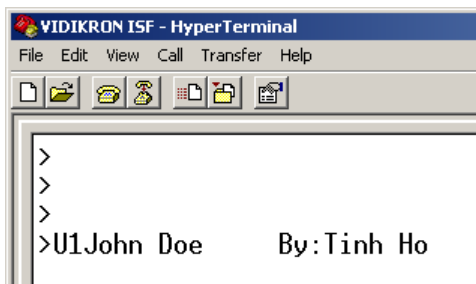

6. Press **<Enter>**.
7. Press **MENU** on the projector remote control. Then, select **ISF Calibration** from the Main menu.
8. Select **ISF Enable** from the ISF Calibration menu and set it to **On**.

9. Power-cycle the projector to see the change:



RUMA-011145
rev. 03-20-07 v2.1



Vidikron
2900 Faber Street
Union City, CA 94587
510-324-5900
Fax 510-324-5905
1-888-4-VIDIKRON
www.vidikron.com



SERIAL NUMBER

Free Manuals Download Website

<http://myh66.com>

<http://usermanuals.us>

<http://www.somanuals.com>

<http://www.4manuals.cc>

<http://www.manual-lib.com>

<http://www.404manual.com>

<http://www.luxmanual.com>

<http://aubethermostatmanual.com>

Golf course search by state

<http://golfingnear.com>

Email search by domain

<http://emailbydomain.com>

Auto manuals search

<http://auto.somanuals.com>

TV manuals search

<http://tv.somanuals.com>