

Sunbeam®

By UniFlame

Model FC2694B Deluxe Charcoal Grill

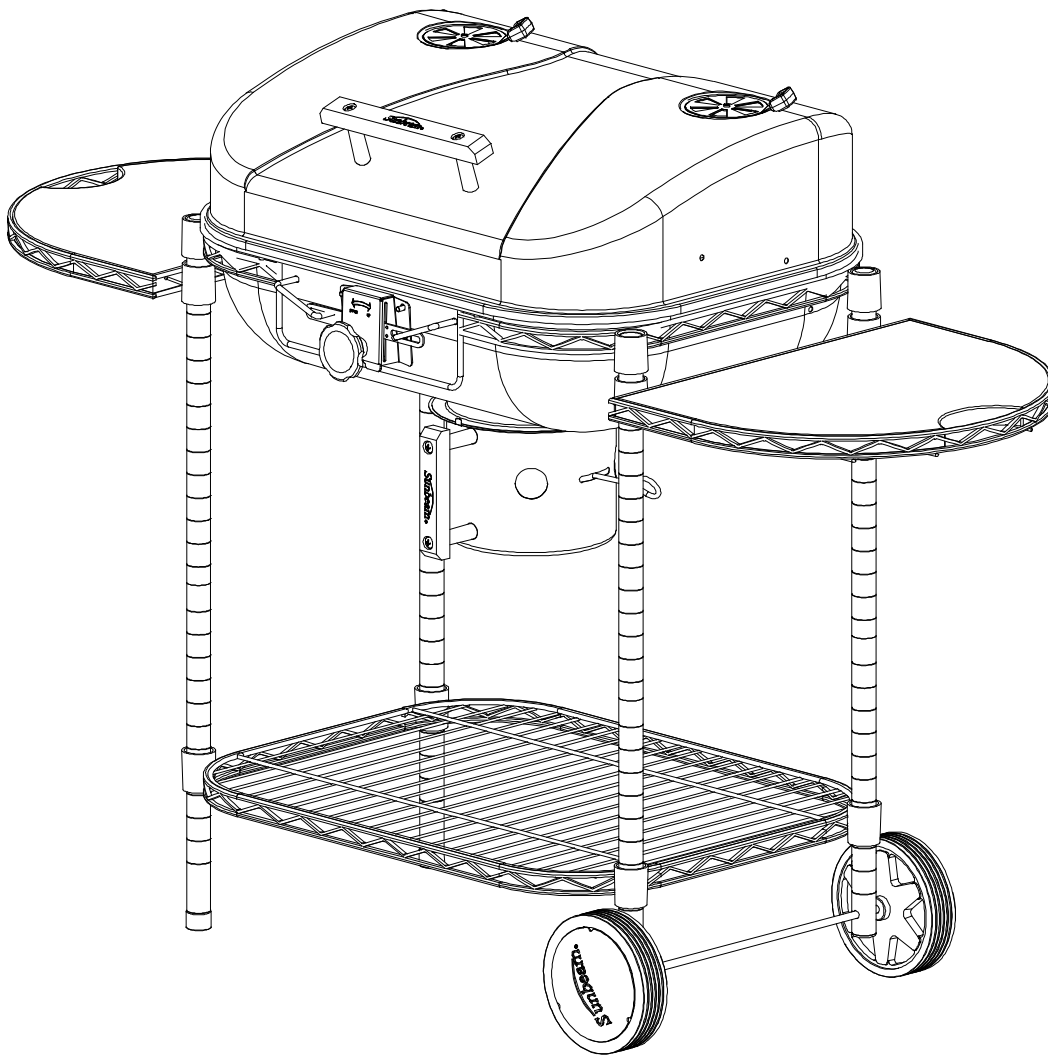

Save these instructions for future reference. If you are assembling this unit for someone else, give this manual to him or her to save for future reference.



Owner's Manual,
Model FC2694B Charcoal Grill

Dear Valued Customer,

Congratulations on your new barbecue grill: You've made the right choice! In this manual, you will find assembly instructions, suggestions for grilling, and helpful hints, as well as guidelines for the safe operation, proper care of, and use of your grill. Our expert staff strives to provide you with an easy to assemble product. However, in the unlikely event that a part is missing or defective, please call our customer satisfaction department seven days a week at (800)762-1142 from 8 a.m. to 5 p.m. central standard time. You also can fax your request to (847) 731-6032. When faxing, please include your name, address, model number, part needed, and the name of the store where you purchased your grill. We then will ship your request as soon as possible. We appreciate and encourage customer feedback. Please contact us if you have any suggestions or comments regarding this product.

Best Regards,

UniFlame Corporation
Customer Satisfaction Department



Owner's Manual,
Model FC2694B Charcoal Grill

IMPORTANT NOTICE: READ ALL INSTRUCTIONS PRIOR TO ASSEMBLY AND USE!

DANGER
DO NOT use charcoal briquettes for indoor cooking or heating. **TOXIC** carbon monoxide fumes can accumulate and cause asphyxiation. Live hot briquettes can create a fire hazard.











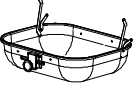





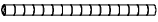
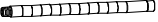
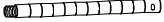

Safety First!

Read and understand all warnings and precautions prior to operating your grill.

WARNING!

- ◆ **DO NOT** use gasoline, kerosene, or alcohol for lighting charcoal briquettes.
- ◆ **ALWAYS** open charcoal grill lid carefully and slowly as heat and steam trapped within grill can severely burn you.
- ◆ **ALWAYS** place the charcoal grill on a hard, level surface far away from combustibles and children.
- ◆ This is **NOT** a tabletop grill! Therefore, **DO NOT** place this grill on any type of tabletop surface
- ◆ **DO NOT** attempt to move the grill once the charcoal briquettes have been lit.
- ◆ **DO NOT** leave a lit grill unattended, *especially* around children and pets.
- ◆ **DO NOT** touch metal parts of grill until it has completely cooled to avoid burns. Unless you are wearing protective gear (Potholders, gloves, BBQ mittens, hot pads & etc.).
- ◆ **DO NOT** remove the ashes until all briquettes are completely and fully extinguished.
- ◆ **DO NOT** place charcoal briquettes directly into bottom of grill. Place the charcoal *ONLY* in the charcoal pan.
- ◆ **DO NOT** place a hot lid onto grass or deck, hang the lid on side of grill.
- ◆ **KEEP** all electrical cords away from a hot grill
- ◆ **DO NOT** use grill in high winds.
DO NOT use the grill unless it is *COMPLETELY* assembled and all parts are securely fastened and tightened.











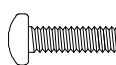

Illustrated Parts List

<p>1: Top Lid1pc 1. Couvercle 1. Tapa</p> 	<p>2.Bottom Bowl1pc 2. Plateau inférieur 2. Bandeja inferior</p> 	<p>3.Cooking Grid1pc 3. Gril de cuisson 3. Parrilla</p> 	<p>4.Charcoal Grid1pc 4. Grille de fond 4. Rejilla del fondo</p> 
<p>5. Lid Air vent 2 sets 5. Registre d'air de couvercle 5. Regulador del aire de tapa</p> 	<p>6.Wrenchs.....2 pcs 6. Clés 6. Llaves</p> 	<p>7.Adjustable Knob.....1pc (Pre-assembled) 7. Bouton réglable (pré-assemblé) 7. Botón ajustable (pre-ensamblado)</p> 	<p>8.Cooking Grid Support Rods (Pre-assembled)1set 8. Tiges de support pour gril de cuisson (pré-assemblé) 8. Varillas de soporte para parrilla (pre-ensamblado)</p> 
<p>9.Straight Legs (Upper).....4 pcs 9. Pattes droites (partie supérieure) 9. Patas derechas (parte superior)</p> 	<p>10. Straight Legs (Lower).....2 pcs 10. Courtes pattes droites 10. Patas cortas derechas</p> 	<p>11.Wheel Legs With Hole.....2 pcs 11. Pattes pour roulettes avec orifice 11. Patas para ruedecillas con orificio</p> 	<p>12. Ash Receiver1set (Pre-assembled) 12. Cendrier (pré-assemblé) 12. Cenicero (pre-ensamblado)</p> 
<p>13.Bottom Slide.....1pc 13. Anneau à glissière 13. Anillo con corredera</p> 	<p>14. Bottom Shelf.....1pc 14. Tablette inférieure 14. Tabla inferior</p> 	<p>15.Wheel Axle1pc 15. Essieu de roulettes 15. Eje para ruedecillas</p> 	<p>16.Bottom Support Rack.....1 pc 16. Structure de support du plateau inférieur 16. Estructura para soporte de bandeja inferior</p> 
<p>17.Side Shelf Insert2pc 17. Structure de tablette latérale 17. Estructura de tabla lateral</p> 	<p>18.Clips24 pcs 18. Attaches 18. Sujetadores</p> 	<p>19. Wheels With Decal2 pcs 19. Roulettes 19. Ruedecillas</p> 	<p>20. Side Shelf.....2pc 20. Tablette latérale 20. Tabla lateral</p> 
<p>21. Lid Handle1pc 21. Poignée de couvercle 21. Manija para tapa</p> 	<p>22. Ash Receiver Handle1pc 22. Poignée de cendrier 22. Manija para cenicero</p> 	<p>23.Hinges (Pre-assembled).....2 sets 23. Penture (pré-assemblé) 23. Pernio (pre-ensamblado)</p> 	



Owner's Manual, Model FC2694B Charcoal Grill

Illustrated hardware list (*Some hardware already assembled to parts above*)

A		Bolts-Large Boulons- Longs Pernos – Largos	4 pcs	H		Medium nuts Écrous capuchon Tuercas capuchón	4 pcs
B		Bolts-Air Damper Boulons pour registre d'air Pernos para regulador del aire	2 pcs	I		Washers-Regular Rondelles régulières Arandelas regulares	7 pcs
C		Bolts Boulons Pernos	3 pcs	J		Lock Washers-Large Grandes rondelles de blocage Arandelas grandes de bloqueo	4 pcs
D		Bolt-Small Boulons- Courts Pernos – Cortos	4 pcs	K		Lock Washers-Small Petite rondelles de blocage Arandelas pequeña de bloqueo	2 pc
E		Regular Wing Nuts Écrous réguliers Tuercas regulares	7 pcs	L		Heat Resistant Washers Rondelles résistantes à la chaleur Arandelas resistentes al calor	4 pcs
F		Large Nuts-Wheels Grands écrous - Roulettes Tuercas grandes – Ruedecillas	2 pcs	M		Rubber spacers	2 pcs
G		Small Wing Nuts For Air damper Petits écrous pour registre d'air Tuercas pequeñas para regulador del aire	2 pcs				

Assembly Instructions

For Best Results

Remove all contents from packaging, and make sure all parts are present before attempting to assemble! Tighten all bolt connections by hand first, then when the grill is fully assembled, go back and tighten.

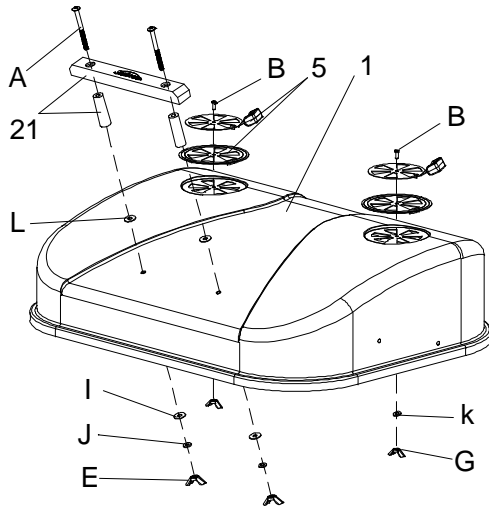

Step 1

Attach two lid air vents (5) to lid (1), using air-damper bolts (B), small lock washers (K) and small wingnuts (G). Then attach the lid handle (21) to the lid using large bolts (A), washers (I), lock washers (J), and wing nuts (E).

Step 2

Attach two clips (18) to each of two lower legs (10), and two lower legs with wheel holes (11), at spot indicated by arrow. *Noted*, when attaching clips, assure that arrow on clips faces upwards. Then slide bottom shelf (14) over four lower legs, and secure on clips. Assure that two legs with wheel holes are together at short end of shelf, and that wheel holes are positioned to allow axle to pass through both legs. Next attach four upper legs (9), to each of the four lower legs by threading them clockwise. Finally insert wheel axle (15) through both legs with wheel holes, and attach wheels with decals by placing rubber spacers (M) between wheel and leg, and securing wheel by popping decal off wheel and using washers (N) and nuts (F). Then reattach decals.

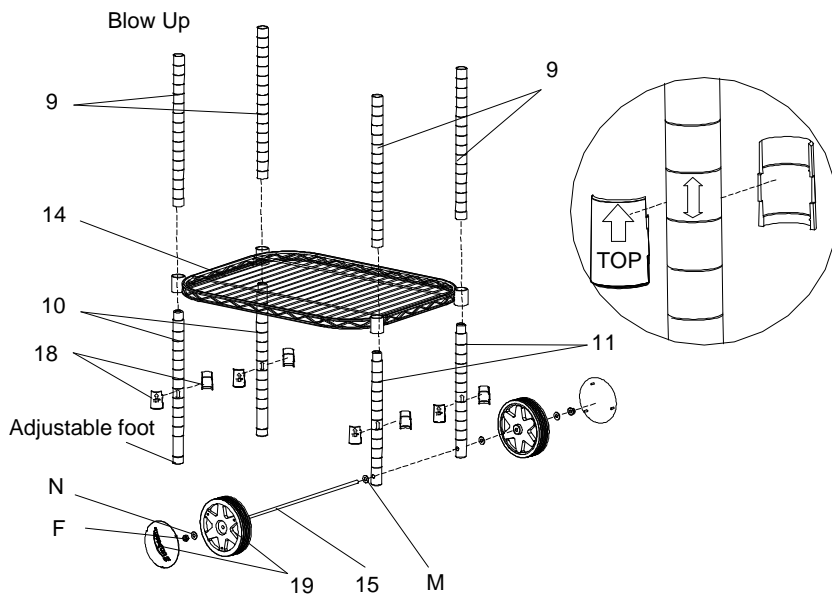

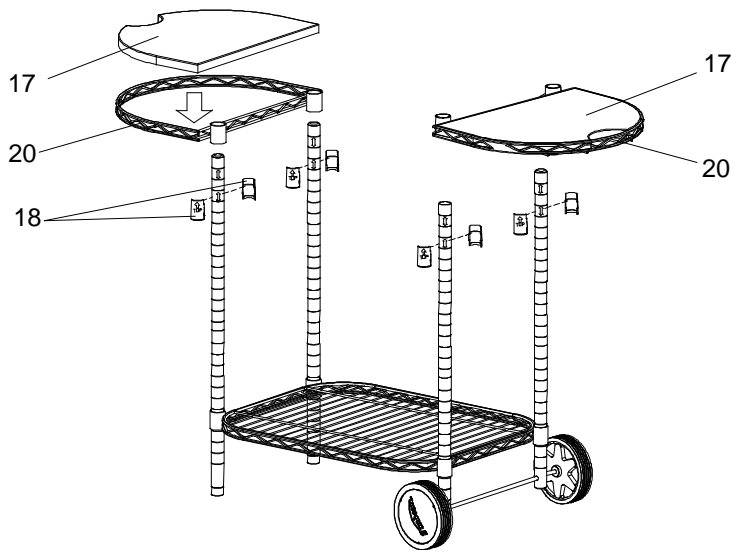

Step 3

Attach two clips (18) to each of four legs at lower of two arrow indicator marks. Assure that arrow on clips faces upwards. Then slide two side shelves (20) onto legs, as shown, securing shelves at clips. Then insert side-shelf inserts (17) into side shelves, as shown.

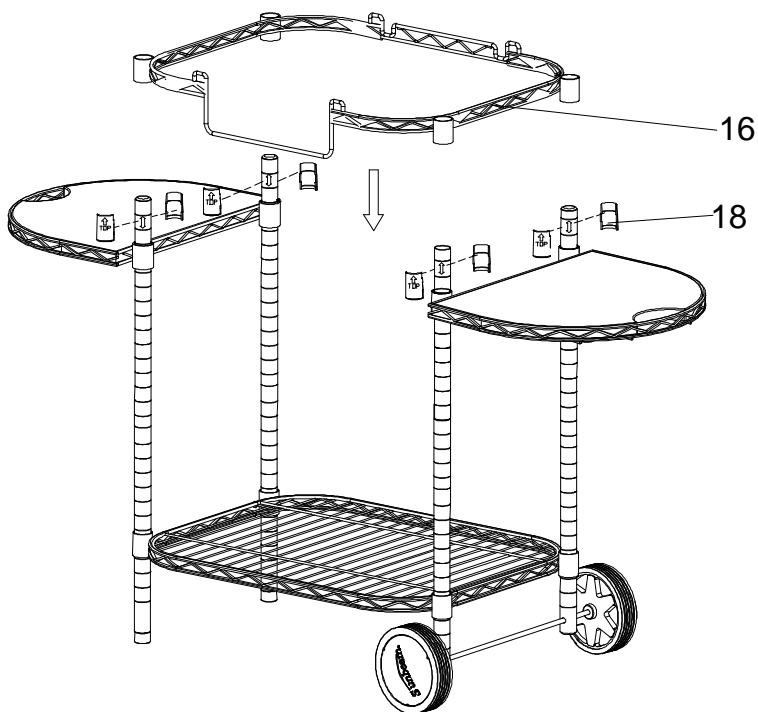

Step 4

Attach two clips (18) to each of four legs at remaining arrow mark, assuring that arrow on clip faces upwards. Then slide support rack (16) onto legs securing at clips, as shown.

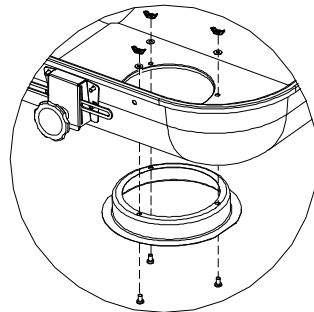
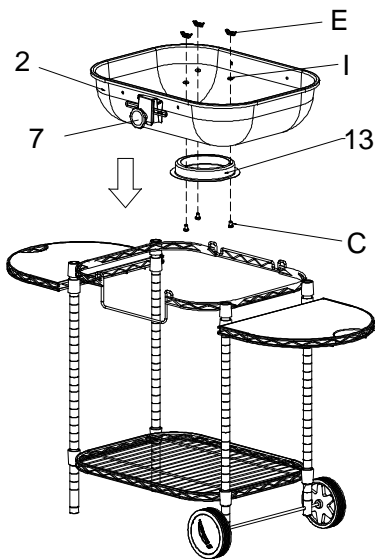

Step 5

Attach bottom slide (13) to bottom bowl (2) using three bolts (C), washers (I), and wing nuts (E). Then place bottom bowl into bottom bowl support, as shown.

Step 6

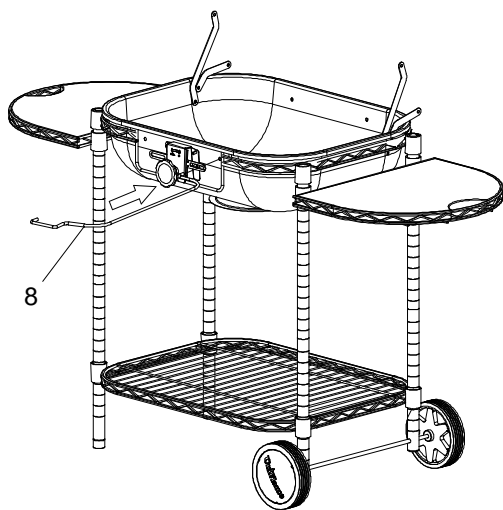

Step A

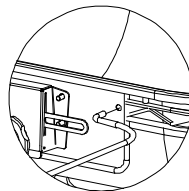

Step B

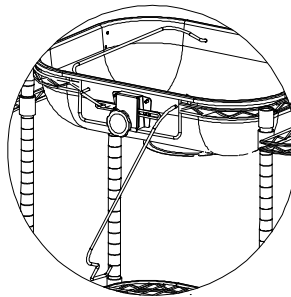

Step C

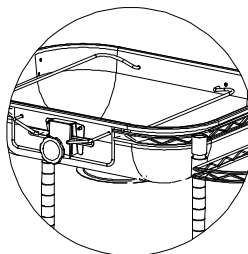

Step D

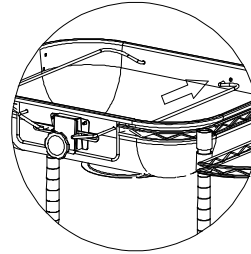

Feed first cooking grid support rod through hole in front of bottom bowl, next to knob (step A). Then angle rod downward to allow bend in rod to fit through hole (step B). Feed long shaft of rod through hole, so entire straight length of rod is inside bottom bowl (step C). Insert end of rod into back of bowl and front end of rod (still protruding from front of bottom bowl) into arm of adjustable knob mechanism (step D).



Owner's Manual, Model FC2694B Charcoal Grill

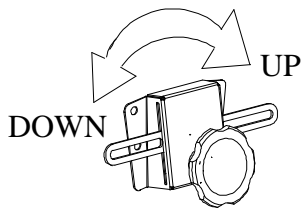

To Adjust Cooking Grid

To LIFT the cooking grid, turn the adjustable knob to the right.
To LOWER the cooking grid, turn the adjustable knob to the left.

Por régler le gril de cuisson

Pour Souldver le gril de cuisson, tournez le bouton réglable vers la droite.
Pour Abaisser le gril de cuisson, tournez le bouton réglable vers la gauche.

Para ajustar la parrilla

Para Levantar la parrilla, gire el botón ajustable hacia la derecha.
Para Bajar la parrilla gire el botón ajustable hacia la izquierda.

Step 7

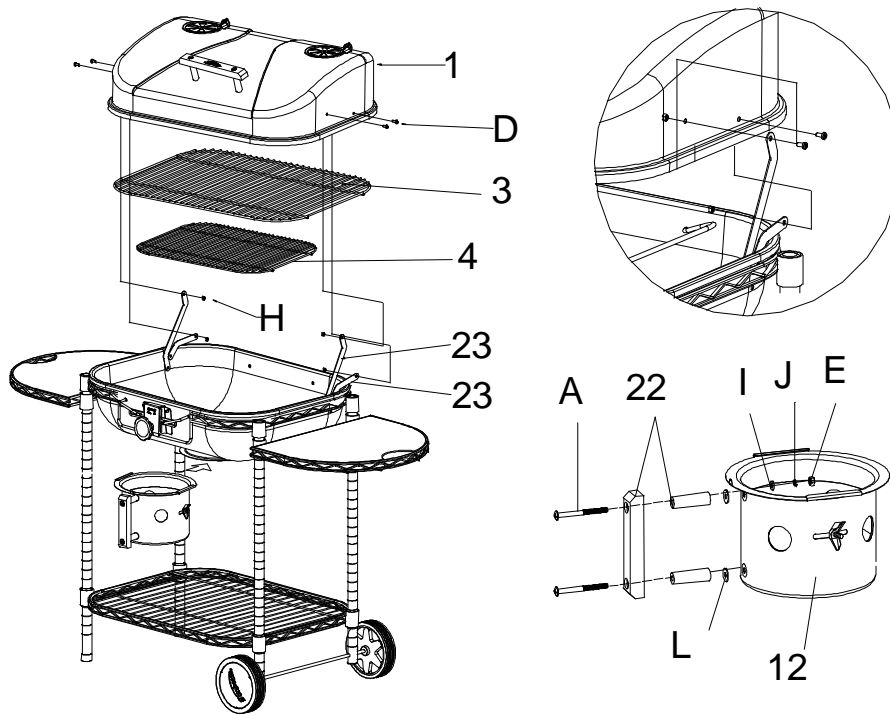

Attach ash receiver handle, (22) to ash receiver (12) using large bolts (A), washers (I), lock washers (J), and wing nuts (E). Set charcoal grid (4) inside bottom bowl underneath cooking grid support rods. Set cooking grid (3) on support rods. Then attach the lid (1), to the two hinges (already attached to the bottom bowl) by using small bolts (D), and medium nuts (H). Then slide ash receiver into bottom slide



Owner's Manual, Model FC2694B Charcoal Grill

OPERATING YOUR GRILL

Lighting your grill



Figure 1:
Pile 2-3 pounds of charcoal in the center of the charcoal grid to light.

1. Make sure lid and vents all are open.
2. Remove the cooking grid. Pile 2-3 pounds of charcoal in the center of the charcoal grid, and shape into a pyramid. (See figure 1.)
3. **If you are using regular charcoal and intend to use lighter fluid**, apply fluid according to the instructions on the container. Allow lighter fluid to soak in for approximately 1 minute before carefully lighting. **If you are using an electric fire starter**, do not add any lighter fluid, and light charcoal according to the instructions from the manufacturer of the fire starter. **If you are using instant-light charcoal**, do not use any extra lighting methods, carefully light charcoal.
4. Allow charcoal to burn for approximately 15-20 minutes, or until all coals are lightly coated in gray ash.



Figure 2:
To cook directly, spread the coals evenly over the charcoal grid after they ash over.

Cooking styles

1. Direct grilling: When the coals have ashed over, using a long-handled cooking utensil and wearing protective cooking mitts, spread the coals evenly over the charcoal grid. Place the cooking grid back onto the grill and arrange food on cooking grid. You can cook food with lid open or closed. (See figure 2.)
Indirect grilling: When the coals have ashed over, using a long-handled cooking utensil and wearing protective cooking mitts, arrange charcoal in a donut shape, leaving an open space in the center. In the center opening, put a small drip pan (not included) to catch drippings. Place food on the cooking grid directly above the drip pan. Cook with lid open or closed. (See figure 3.)
3. Smoking: soak any fragrant wood chips in water over night so they will not burn when you put them on the charcoal. After spreading the coals per the direct cooking method, above, place wood chips on charcoal. Cook with lid closed and cooking grid, if adjustable, set to it's highest (away from coals) setting.



Figure 3:
To cook indirectly, put a small drip pan in the center of the grill, surrounded by charcoal, and place meat directly above the drip pan.



Owner's Manual,
Model FC2694B Charcoal Grill

General Helpful Hints for Successful Charcoal cooking

1. Store your charcoal in a dry place. If storing outside, seal charcoal in a waterproof container.
2. When removing lid during cooking, if your lid is not hinged, lift to one side instead of straight up. As lifting straight up will create a vacuum within the grill sucking up the ash into the food.
3. When cleaning your grill **DO NOT** use abrasive cleaners, for it will damage the parts of this product. Clean all grids and pans with mild detergent. Rinse clean with water. Remove all ash and dispose properly.



Award-Winning Barbecue Recipes

Never-fail barbecue sauce

Ingredients:

¼ cup	Finely Chopped Onion
2 tablespoons	Butter Or Margarine
¼ cup	Brown Sugar, Firmly Packed
1 tablespoon	Worcestershire Sauce
¼ teaspoon	Hot Pepper Sauce
1	Clove Garlic, Finely Chopped
1 cup	Catsup
¼ cup	Lemon Juice
1 teaspoon	Prepared Mustard

Prepare:

Cook onion and garlic in margarine until tender. Add remaining ingredients and bring to a boil. Simmer uncovered 15 to 20 minutes. Refrigerate leftovers after using.

Mamma's Marinated Chicken

Ingredients:

¼ cup	Dijon mustard
2 tablespoons	fresh lemon juice
1 ½ teaspoons	Worcestershire sauce
½ teaspoon	dried tarragon
¼ teaspoon	freshly ground black pepper
4	boneless skinless chicken breast halves

Prepare:

Combine ingredients, mixing well. Marinate chicken for several hours. Grill uncovered, over medium heat, for 10 to 15 minutes or to taste.

Barbecued Honey Steak

Ingredients:

5 pounds	Beef sirloin steak
2 tablespoons	Red pepper -- crushed
1 teaspoon	Black pepper
2	Garlic cloves -- crushed
1 large	Onion
1 cup	Honey

Prepare:

Combine all ingredients and marinate steak for 7-8 hours. Remove meat from marinade and grill over very high heat. Heat leftover marinade and pour over grilled steak to serve.



Owner's Manual, Model FC2694B Charcoal Grill

Hardcore Grilled Trout

Ingredients:

1/4 cup lemon or lime juice
2 tablespoons melted butter
2 tablespoons vegetable oil
2 tablespoons chopped parsley
1 tablespoon hot sauce
1/2 teaspoon ground ginger
1/2 teaspoon salt
4 brook trout -- about 1 pound each

Prepare:

Combine lemon juice, margarine, oil, parsley, sesame seeds, hot sauce, ginger and salt. Mix well. Pierce skin of fish in several places. Roll fish in juice mixture to coat inside and out. Cover. Refrigerate 30 minutes to 1 hour, turning occasionally. Remove fish from marinade. Place fish on grill; brush fish with marinade while grilling. Cook over high heat for 5 minutes. Turn; brush with marinade, cook 5 minutes longer. Fish is done when it flakes easily with fork – Cook to taste.

Grilled Veggies

Ingredients:

3/4 cup Olive oil
1/4 cup Red wine vinegar
1 teaspoon Fresh rosemary
1 teaspoon Fresh thyme leaves
1 teaspoon Fresh basil; chopped
1 teaspoon Fresh oregano; chopped
1 tablespoon minced garlic
1/2 teaspoon salt
1/2 teaspoon Ground black pepper
2 pounds assorted vegetables, chopped or whole, according to taste.

Prepare

Combine all ingredients in a small bowl. Marinade vegetables with sauce, and cover and refrigerate for 2 hrs. Grill vegetables over medium heat until tender, brushing them with marinade while they cook. Cooking times will vary according to the vegetables chosen.



Owner's Manual, Model FC2694B Charcoal Grill

1 YEAR LIMITED WARRANTY

UniFlame Corporation warrants to the original retail purchaser of this grill that if it is assembled and operated in accordance with the printed instructions accompanying it then for a period of one (1) year from the date of purchase. All parts shall be free from defects in material and workmanship. UniFlame may require reasonable proof of your date of purchase. Therefore, you should retain your sales slip or invoice.

This Limited Warranty shall be limited to the repair or replacement of parts, which prove defective under normal use and service and which on examination, shall indicate, to UniFlame's satisfaction, they are defective. Before returning any parts, contact UniFlame's Customer Service Department. If UniFlame confirms the defect and approves the claim, UniFlame will elect to replace such parts without charge. If you are required to return defective parts, transportation charges must be prepaid. UniFlame will return parts to the purchaser, freight or postage prepaid.

This Limited Warranty does not cover any failures or operating difficulties due to accident, abuse, misuse, alteration, misapplication, improper installation or improper maintenance or service, or failure to perform normal and routine maintenance, as set out in this owners manual. There are no other express warrants except as set forth herein and any applicable implied warranties of merchantability and fitness are limited in duration to the period of coverage of this express written Limited Warranty. Some states do not allow limitation on how long an implied warranty lasts, so this limitation may not apply to you.

UniFlame is not liable for any special, indirect or consequential damages. Some states do not allow the exclusion or limitation of incidental or consequential damages, so this limitation or exclusion may not apply to you.

UniFlame does not authorize any person or company to assume for it any other obligation or liability in connection with the sale, installation, use, removal, return, or replacement of its equipment, and no such representations are binding on UniFlame.

UniFlame Corporation
1817 N. Kenosha Road
Zion, Illinois 60099, USA
(800) 762-1142
24 Hour Fax: (847) 731-6032

Free Manuals Download Website

<http://myh66.com>

<http://usermanuals.us>

<http://www.somanuals.com>

<http://www.4manuals.cc>

<http://www.manual-lib.com>

<http://www.404manual.com>

<http://www.luxmanual.com>

<http://aubethermostatmanual.com>

Golf course search by state

<http://golfingnear.com>

Email search by domain

<http://emailbydomain.com>

Auto manuals search

<http://auto.somanuals.com>

TV manuals search

<http://tv.somanuals.com>