

Digital Camcorder

Operating Instructions

Before operating the unit, please read this manual thoroughly and retain it for future reference.

Power HAD



DSR-500WSL/500WSPL

WARNING

To prevent fire or shock hazard, do not expose the unit to rain or moisture.

To avoid electrical shock, do not open the cabinet. Refer servicing to qualified personnel only.

Owner's Record

The model and serial numbers are located on the top. Record these numbers in the spaces provided below. Refer to them whenever you call upon your Sony dealer regarding this product.

Model No. _____ Serial No. _____

LITHIUM BATTERY

Replace the battery with a Sony CR2032 lithium battery. Use of another battery may present a risk of fire or explosion.

WARNING

Battery may explode if mistreated.
Do not recharge, disassemble or dispose of in fire.

Note

Keep the lithium battery out of the reach of children.
Should the battery be swallowed, consult a doctor immediately.

ADVARSEL!

Lithiumbatteri - Eksplosionsfare ved fejlagtig håndtering.
Udskiftning må kun ske med batteri af samme fabrikat og type.
Levér det brugte batteri tilbage til leverandøren.

ADVARSEL

Lithiumbatteri - Eksplosjonsfare.
Ved utskifting benyttes kun batteri som anbefalt av apparatfabrikanten.
Brukt batteri returneres apparatleverandøren.

WARNING

Explosionsfara vid felaktigt batteribyte.
Använd samma batterityp eller en likvärdig typ som rekommenderas av apparattillverkaren.
Kassera använt batteri enligt gällande föreskrifter.

VAROITUS

Paristo voi räjähtää jos se on virheellisesti asennettu.
Vaihda paristo ainoastaan laitevalmistajan suosittelemaan tyyppiin.
Hävitä käytetty paristo valmistajan ohjeiden mukaisesti.

For customers in the USA (DSR-500WSL only)

This equipment has been tested and found to comply with the limits for a Class A digital device, pursuant to Part 15 of the FCC Rules. These limits are designed to provide reasonable protection against harmful interference when the equipment is operated in a commercial environment. This equipment generates, uses, and can radiate radio frequency energy and, if not installed and used in accordance with the instruction manual, may cause harmful interference to radio communications. Operation of this equipment in a residential area is likely to cause harmful interference in which case the user will be required to correct the interference at his own expense.

You are cautioned that any changes or modifications not expressly approved in this manual could void your authority to operate this equipment.

The shielded interface cable recommended in this manual must be used with this equipment in order to comply with the limits for a digital device pursuant to Subpart B of Part 15 of FCC Rules.

For customers in Europe (DSR-500WSPL only)

This product with the CE marking complies with the EMC Directive (89/336/EEC) issued by the Commission of the European Community.

Compliance with this directive implies conformity to the following European standards:

- EN55103-1: Electromagnetic Interference (Emission)
- EN55103-2: Electromagnetic Susceptibility (Immunity)

This product is intended for use in the following Electromagnetic Environment (s):

E1 (residential), E2 (commercial and light industrial), E3 (urban outdoors) and E4 (controlled EMC environment, ex. TV studio)

Table of Contents

Chapter 1

Overview

Product Configurations	7
Features	8
Features on Camera Section	8
Features on VCR Section	10
Location and Function of Parts	12
Front View	12
Right Side View	13
Left and Upper View	23
Rear and Bottom	25
VCL-918BY Zoom Lens (not supplied)	27
DXF-801/801CE Viewfinder	29

Chapter 2

Fitting and Connections

Inserting and Replacing the Lithium Battery	31
Fitting the Lens	32
Using Accessories	34
Using the Viewfinder	34
Fitting the 4-inch/5-inch Electronic Viewfinder	35
Fitting to a Tripod	35
Using an Optional Microphone	36
Using a Video Light	37
Fitting the Shoulder Strap	38
Connecting to Audio System	39
Using the Optional RM-VJ1 Remote Control Unit (Equipped With Microphone And Monitor)	41
Using the RM-LG1 Remote Control Unit	42
Using the Optional LC-DS500 Carrying Case	43
Using the Optional LC-DS300SFT Soft Carrying Case ...	43
Connections	44
Connecting a Number of Camcorders	44
Connecting the DSR-70/70P Digital Videocassette Recorder (Optional DSBK-140 Is Required)	45
Connecting an External VCR	45
Power Supply	46
Using a BP-L40/L40A/L60/L60A/L90/L90A Battery Pack	46

Table of Contents

Using an AC Adaptor	48
Using the Anton Bauer Intelligent Battery System	48

Chapter 3

Shooting

Basic Procedure for Shooting	49
Using DynaLatitude Function	50
Recording	51
Cassettes for the DSR-500WSL/500WSPL	51
Recording on the Internal VCR	52
Recording an External Video Signals	56
Recording on an External VCR Using the VTR Connector (26-pin)	56
Recording on an External VCR Using the DV OUT Connector	57
Back Space Editing	58
Starting Back Space Editing at Any Tape Position	58
Using the Edit Search Function While Back Space Editing	59
Using the Freeze Mix Function	60
Playback — Checking Recorded Contents	61
Checking the Recorded Contents Immediately After Shooting — Recording Review	61
Viewing Monochrome Playback in the Viewfinder	61
Viewing Color Playback	61
Setting Time Values	62
Setting the User Bit Value	63
Setting the Time Code Value	64
Synchronization With External Time Code Signals — Gen-Lock	66
ClipLink Shooting	68
Setting Editing Points While Shooting	70
Resuming Recording in ClipLink Mode	72

Chapter 4

Viewfinder Screen Indications and Menus

Viewfinder Screen Indications	75
Changing the Viewfinder Display	75

Viewfinder Normal Indications	76
Status Indications	79
Viewfinder Basic Menu	80
Basic Menu Operations	80
Contents and Settings of Each Menu Page.....	80
Viewfinder Advanced Menu	86
Advanced Menu Operations	86
Contents and Settings of Each Menu Page.....	87
Video Output and Viewfinder Picture	93
Setup Files	94
Calling up a Setup File	94
Changing File Settings	96
Saving File Settings	96
Using SetupNavi and SetupLog	99
Setting Up the Camera Using Data Recorded on Tape	99
Recording the Menu Settings Onto a Tape	100
Viewing SetupLog Data	101

Chapter 5

Adjustments and Settings

Setting on the VCR Section — VCR Menu	103
VCR Menu Operation	104
Basic Operation	104
Menu 101 Setting the Real Time Clock and Calendar ...	105
Menu 201 Checking the Total Operating (Power-On) Hours	105
Menu 204 Selecting Frame Mode (DF/NDF) for Time Code (for DSR-500WSL Only)	105
Menu 206 Selecting Battery Capacity Indication	106
Menu 207 Setting Standby-On Period	106
Menu 210 Using Auto-Check Function	107
Menu 211 Selecting ClipLink Function	109
Menu 212 Selecting Audio Recording Mode	109
Menu 213 Selecting Audio Reference Level	110
Menu 214 Setting Fade-In/Fade-Out for the Audio Recording Start and Stop Points	110
Menu 220 Using Setup Add (for DSR-500WSL Only)	111

Table of Contents

Menu 221 Using Setup Remove (for DSR-500WSL Only)	111
White Balance Adjustment	112
Saving an Appropriate White Balance Value in Memory	112
Using the Preset White Balance Settings	113
Light Sources and Color Temperature	114
Using the ATW (Auto Tracing White Balance) Function	114
Black Balance Adjustment	115
Shutter Settings	116
Viewfinder Screen Adjustments	118
Adjusting the Lens	119
Flange Focal Length Adjustment	119
Iris Adjustments	120
Adjusting the Iris Sensitivity	121
Macrophotography	121
Settings for Special Cases	122
Skin Detail Correction	123
Adjusting Color in the Specified Area	123

Appendix

Important Notes on Operation	125
Characteristics of CCD Sensors	125
Cleaning the Video Heads	126
Warning System	127
Condensation	128
Troubleshooting	129
Specifications	131
Related Products	133
Measuring Horizontal Resolution	134
Chart of Optional Components and Accessories	135
What is ClipLink?	136
How ClipLink Changes Video Production Techniques ...	136
ClipLink Operation Flow	137
Example System Configuration	137
Data Generated When Shooting	138
Glossary	141

Product Configurations

The DSR-500WSL/500WSPL consists of the following items:

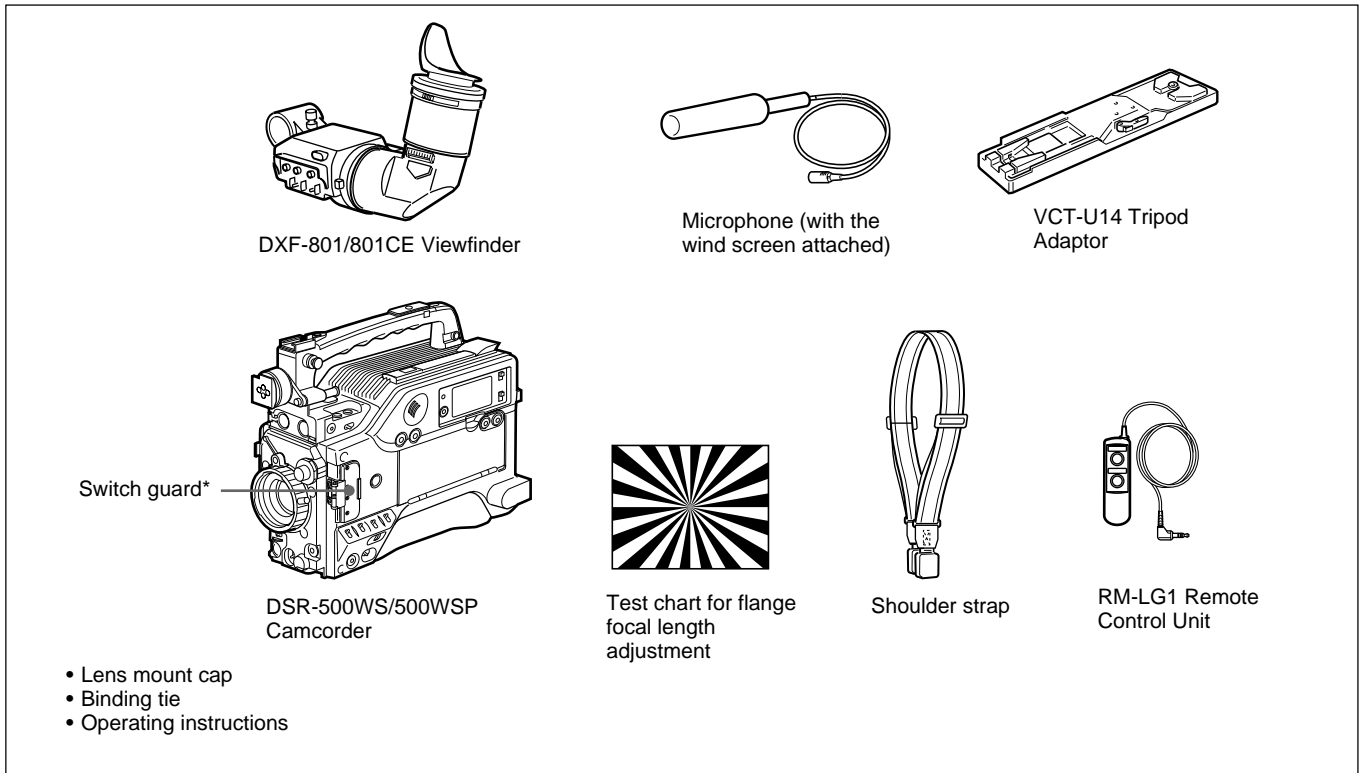

* The switch guard can be removed. (See page 12.)

Features on Camera Section

2/3-inch IT type Power HAD WS CCD

The DSR-500WSL/500WSPL Digital Camcorder uses a newly developed 520,000-pixel Power HAD WS (wide screen) CCD, for outstanding sensitivity and picture quality.

- Sensitivity: F11.0 (at 3200 K, 2000 lux)
- S/N: 63 dB
- Smear: -120 dB

Switchable between 16:9 and 4:3 aspect ratios

A simple menu operation provides instant switching between the 16:9 and 4:3 aspect ratios. In 4:3 mode, a screen equivalent to a 4:3 screen is obtained through digital processing of the 16:9 video signals produced by the WS CCD. (See page 92.)

Wide-aspect ID signals

A menu setting is available to add wide-aspect ID signals¹⁾ to 16:9-mode video signals.²⁾ (See page 92.)

Automatic aspect ratio switching in viewfinder

When the supplied DXF-801/801CE viewfinder is used, the viewfinder scan size automatically switches in accordance with the aspect ratio (16:9 or 4:3) selected for the camera. (See page 92.)

Sophisticated image processing

TruEye™ processing makes possible the following performance features. This digital signal processing has brought reproduction of natural colors to the level achieved by the human eye.

DynaLatitude™

Enables detailed adjustment of contrast control in each pixel in accordance with a histogram of luminance signal levels. (See pages 50, 81 and 88.)

DCC+ (dynamic contrast control plus)

Prevents white breakup when shooting a high intensity subject, and also prevents color faults in high intensity subject.

Black stretch and compress

Enables control of luminance signal levels in black areas without changing the hue.

Variety of detail corrections

- Skin detail function: this function gives a slightly softer appearance to the subject's face. The target skin color can be automatically set.
- Black halo correction
- Red/green vertical detail correction: this function performs vertical detail compensation for both red and green signals.
- Horizontal detail frequency control

Recording and managing setup data

In addition to the setup menu that is displayed in the viewfinder screen, the DSR-500WSL/500WSPL is equipped with the following functions to facilitate camcorder setup.

Setup file system

You can use setup files when making adjustments or settings. The DSR-500WSL/500WSPL comes with factory preset files that contain shipped settings and you can freely create user files as well. (See page 94.)

1) ID signals complying with EIAJ CPR-1204 (DSR-500WSL) or complying with ETS WSS (DSR-500WSPL).

2) Video signals refer to the following:

- Video signals output from the VIDEO OUT connector and MONITOR OUT connector.
- The Y component of Y/C separate signals and the Y component of component signals output from the VTR connector.

Automatic recording of setup data (page 99)

SetupLog™: Shooting-related environment settings are recorded onto the tape at intervals of a few seconds. This recorded data can be used to reproduce the same shooting conditions in subsequent shots. It also makes it easier to identify the causes of problems in previous shots.

SetupNavi™: The setup conditions selected with the setup menu and setup files are recorded onto the tape. The recorded setup data can be copied to other camcorders so that the same setup can be shared among several camcorders.

Functions boost operability

Controlling with the RM-VJ1 Remote Control Unit

You can control this unit while watching the image with the optional RM-VJ1 Remote Control Unit (equipped with the microphone and monitor). (See page 41.)

EZ (easy) mode function

When there is no time to check the camcorder settings, simply press the EZ MODE button to start the auto adjustment function using standard settings. There is no need to lose a shot for lack of setup time. (See pages 13, 14, 90 and 91.)

EZ (easy) focus

Press the EZ FOCUS button before shooting to ensure a quick and accurate focus. (See page 13.)

Dual pixel readout (DPR¹⁾)

When the gain is set to either 18 dB or 24 dB, the gain setting can be doubled (6 dB up) without increasing the noise level.

Programmable gain

The amount of gain relative to the GAIN switch setting (H, M, or L) can be programmed as -3 dB, 0 dB, 3 dB, 6 dB, 9 dB, 12 dB, 18 dB, 18 dB+DPR, 24 dB, 24 dB+DPR, and hyper gain. (See page 88.)

Hyper gain

Hyper gain (36 dB or 42 dB, i.e. about 60 times or 120 times greater than 0 dB) can be easily set via one switch setting. This can also be done from remote equipment. (See pages 21, 22 and 88.)

Auto tracing white balance (ATW)

This function automatically traces the white balance, which constantly changes as lighting conditions change. Auto tracing white balance is especially useful when there is no time to manually adjust the white balance or when shooting moves between indoor and outdoor locations. (See pages 13, 14 and 114.)

Total level control system (TLCS)

Even if the incoming light exceeds the range in which the standard auto iris can control exposure, the auto gain control (AGC) or auto exposure (AE) backs up to ensure proper exposure. (See pages 14 and 90.)

Recording time (REC TIME) display

Recording time can be displayed in either of the following modes. (See pages 21 and 82.)

- Total recording time for all cuts (TTL²⁾)
- Total recording time for current cut (DUR³⁾)

Viewfinder super detail

Video signals for the viewfinder are mixed with DTL signals to make focusing easier.

Dual zebra pattern display

Two types of zebra patterns, zebra 1 and zebra 2 can be displayed simultaneously or independently. The zebra 1 can be set to the levels ranging from 70 to 90 IRE on the DSR-500WSL (or from 70 to 90% on the DSR-500WSPL) and the zebra 2 indicates the levels of 100 IRE or more for the DSR-500WSL (or the levels of 100% or more for the DSR-500WSPL). (See pages 13, 14 and 89.)

Color temperature display

When reading the white balance, the color temperature is displayed on the viewfinder screen. (See page 112.)

1) DPR = Dual Pixel Readout
2) TTL = Total

3) DUR = Duration

Features

Switching the color temperatures for the preset white balance

You can select the preset white balance at 3200 K (default) or 5600 K (default) by setting the FILTER control. The preset white balance can be changed to other value through menu setting (*See page 81*).

Video monitor output with text

The video signal with text superimposed that is shown in the viewfinder can also be output to an external video monitor. (*See pages 19 and 20*.)

1-kHz reference signal output

Along with a color bar, a 1-kHz reference signal can also be output. (*See page 88*.)

Freeze mix function

The freeze mix function superimposes any previously recorded still picture on the viewfinder screen to facilitate framing the subject when reshooting the scene. (*See page 60*.)

Edit Search Function

Pressing the EDIT SEARCH buttons allows the tape to play back in search mode. Set either of two playback speeds. (*See pages 13 and 59*.)

Video light control

A video light connector and control switch are equipped. You can turn the light on and off automatically as you start and stop VCR operation. (*See page 13*.)

High-performance DXF-801/801CE Viewfinder (page 118)

- Switching the aspect ratio automatically between 16:9 and 4:3
- High resolution (600 TV lines of horizontal resolution)
- Large-diameter eye cup for easier viewing and focusing
- PEAKING potentiometer for vertical and horizontal detail control
- Three indicators can be used as TALLY indicators
- Tough die-cast aluminum body
- DISPLAY switch that can turn the character display on and off
- Light that can light the lens control elements

Features on VCR Section

The DSR-500WSL/500WSPL uses the DVCAM recording format. The internal signal processing is digitalized to provide more stable output signals and higher reliability.

Compatible with consumer DV

A DV cassette recorded on a DV-format VCR can be played back on the DSR-500WSL/500WSPL. (Cassettes recorded in LP mode cannot be played back.) (*See page 51*.)

DVCAM cassettes (page 51)

- The DSR-500WSL/500WSPL can use both standard-size and mini-size DVCAM cassettes. According to cassette size, the DSR-500WSL/500WSPL automatically corrects reel position.
- The maximum recording/playback times are 184 minutes for standard size cassettes and 40 minutes for mini cassettes.
- DVCAM cassettes include a cassette memory. Information about the editing points (ClipLink™ log data) that is specified while shooting is recorded into this cassette memory.

Recordable the external video signals

Fitting the optional DSBK-501/501P Analog Composite Input Board enables the camcorder to record the external analog video signals. (*See pages 24, 56 and 81*.)

ClipLink™ function

The ClipLink function links all stages from shooting to editing. Once editing points have been set with this function during shooting, they can be used to boost the efficiency of editing work. However, this function does not work when using the DV OUT connector. (See pages 68, 109 and 136.)

Creation of clips

Using the ClipLink function, the camcorder operator can create clips to be used during editing. The images captured at the Mark IN points are recorded in a compressed format onto the tape as "Index Pictures." In addition, editing point-related data (scene number, time code for Mark IN/OUT points, etc.) is recorded in the cassette memory.

ClipLink mode

To use the ClipLink function, select the menu setting to set the DSR-500WSL/500WSPL into ClipLink mode. There is also a ClipLink continue function that enables clips to be continued even after a break in recording.

PCM digital audio

Recording/playback can be set to audio lock mode. Selectable between two-channel recording (with a sampling frequency of 48 kHz) mode or four-channel recording (with a sampling frequency of 32 kHz) mode (CH-1 and CH-2 only). (See pages 16, 17, 55 and 109.)

Equipped with audio output connectors

During recording or playback, audio output can be monitored via a built-in speaker, a connected earphone or via (two-channel) audio output connectors. (See pages 24 and 25.)

Color playback

Connect an external video monitor for color playback (playback adaptor not required). The DSR-500WSL/500WSPL is equipped with two video monitor connectors: one for composite video output and the other for S-video output. (See page 24.)

VCR data display

The DSR-500WSL/500WSPL is able to display the following data on the viewfinder screen. (See pages 76, 89 and 90.)

- Time values (counter, time code, or user bit values)
- Audio recording levels
- Remaining tape time
- Operation mode of the VCR section
- Remaining battery capacity
- ClipLink information

Recording on external VCRs

Betacam or S-VHS VCRs can be connected to the VTR connector (26-pin) on the rear panel. (See pages 25, 26, 45 and 56.)

Equipped with the DV OUT connector

The DV OUT connector is i.LINK¹⁾ compatible. You can connect with the Sony equipment which has the DV input connector.

You can do cut editing and digital dubbing if you connect the DSR-70/70P Digital Videocassette Recorder (with the DSBK-140 is fitted) to the DV OUT connector on the camcorder, using an i.LINK cable (DV connecting cable). (See pages 25, 26, 45 and 57.)

1)  is a trademark of Sony Corporation and indicates that this product is in agreement with IEEE 1394-1995 specifications and their revisions.

Location and Function of Parts

Front View

10 Switch guard

How to remove the switch guard

1. Detach the two screws (M3).
2. Remove the switch guard, and replace the screws detached in step 1.

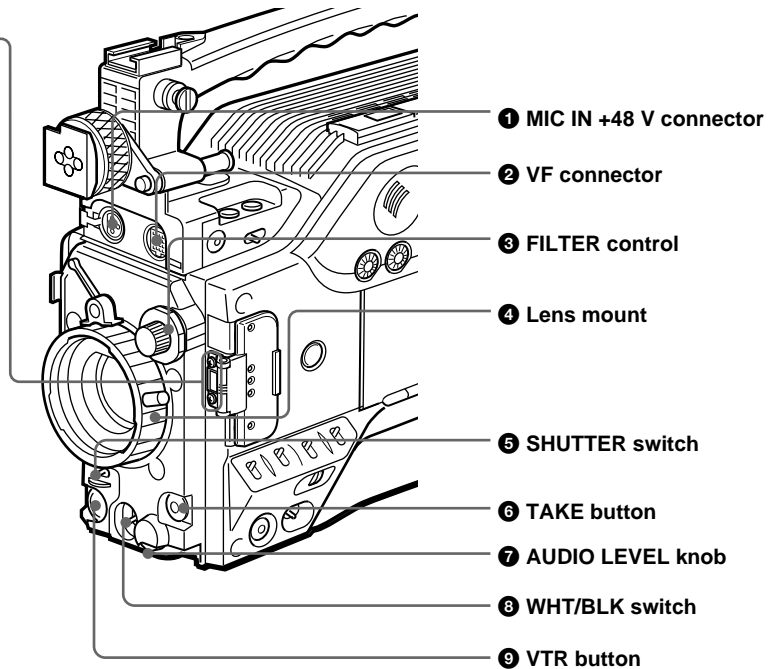
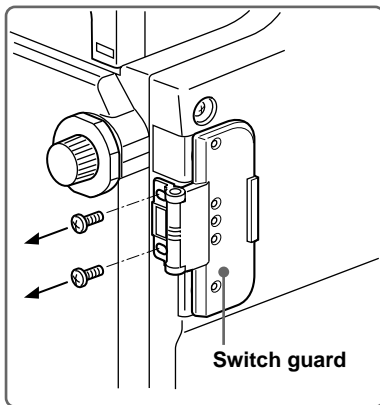

1 MIC (microphone) IN +48 V connector (XLR 3-pin, female)

Connect the supplied microphone or an optional microphone (operable with a 48 V supply).

2 VF (viewfinder) connector (20-pin)

This is the connector for the DXF-801/801CE viewfinder.

3 FILTER control

Select the color temperature conversion filter appropriate to the lighting conditions. (See page 49.)

4 Lens mount

Attach the optional zoom lens here.

5 SHUTTER switch

Use this switch to set the shutter speed, CLS (clear scan), or EVS setting (see page 116). Usually, set this switch to OFF.

6 TAKE button

Press this button to specify an editing point (Mark IN/OUT or Cue point) at the current tape position during shooting. (See pages 70 and 71.)

7 AUDIO LEVEL knob

You can use this knob to manually adjust the channel 1 audio recording level.

8 WHT/BLK (white/black) switch

This switch is used for automatic adjustment of the white balance and black balance. (See pages 112 to 115.)

9 VTR button

Pressing this button starts and stops recording on the VCR.

10 Switch guard

Avoids miss-operation of the EZ MODE button (4 on page 14), A.IRIS MODE switch (6 on page 14), and ATW button (14 on page 14). When using these buttons and switch, open the guard.

Right Side View

Front section

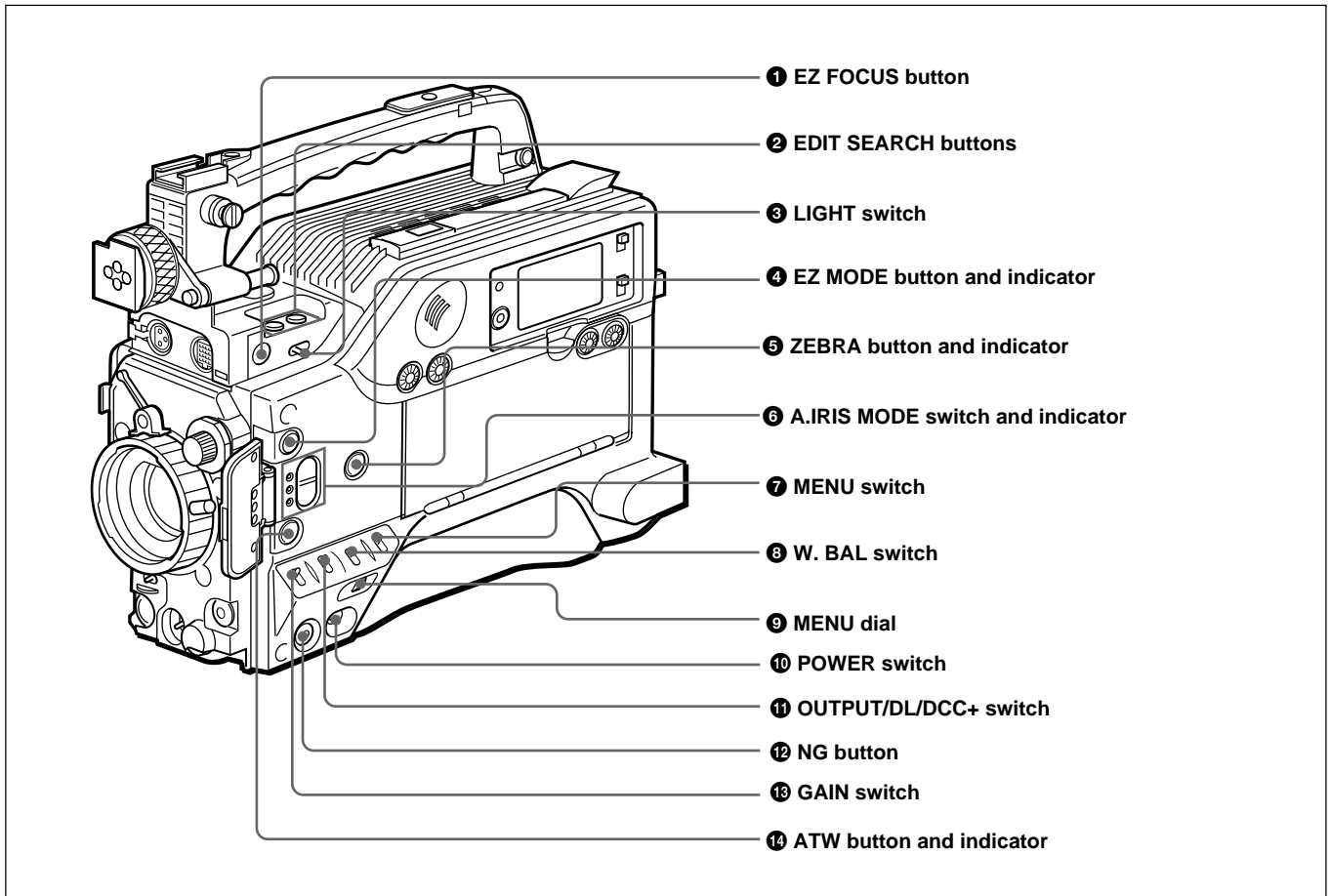

❶ EZ FOCUS button

Press this button to turn the “easy focus” function on. This opens the iris, to make it easier to focus before beginning shooting. The indication “EZ FOCUS” appears in the viewfinder while the function is on; to turn it off, press the EZ FOCUS button again. If left on, the function automatically turns off after about ten seconds.

Note

If the “easy focus” function is still on when you press the VTR button on the camcorder or the lens, it turns off automatically and recording starts about one second later.

❷ EDIT SEARCH buttons

You can see the search playback while pressing either of these buttons at recording pause mode to quickly find the next recording start point. Two playback speeds are available, and press either of the buttons to the inner position to increase the speed.

❸ LIGHT (video light) switch

Controls the video light connected as follows.

AUTO: turns on the video light at recording if the power switch on the light is set on.

MAN (manual): allows the power switch on the video light to turn the light on and off.

Location and Function of Parts

4 EZ (“easy”) MODE button and indicator

Press this button (EZ mode on) when you want to be able to shoot immediately, with automatic adjustment of the camcorder settings to standard values. (See page 91 for EZ mode settings.) When this function is used, the iris and the white balance are adjusted automatically. (The total level control system functions.) Press this button again to return the camcorder to the previous settings (EZ mode off).

Note

When the RM-M7G Remote Control Unit is connected or external analog signals are input, the “easy mode” function is disabled.

5 ZEBRA button and indicator

Depress this button to display a zebra pattern (diagonal stripes) in the viewfinder.

Depending on the zebra setting in advanced menu page 4 (see page 89), the zebra 1 for video levels between 70 to 90 IRE (or 70 to 90%) and the zebra 2 for video levels 100 IRE or more (or 100% or more) can be displayed independently or simultaneously.

6 A.IRIS (auto iris) MODE switch and indicator

When you use the auto iris function (by setting the IRIS selector on the lens to A), set this switch to suit the shooting conditions. Selecting BACK L gives more light to back-lit subjects, and selecting SPOT L adjusts for high contrast in spot-lit subjects. For normal shooting, set this switch to STD.

7 MENU switch

When you press this switch to the ON position, the basic menu is displayed. Keep pressing it to the ON position to cycle through the various menu displays. When you press the switch to the STATUS position, the camcorder’s status (of current settings) is displayed.

8 W. BAL (white balance) switch

This selects the white balance setting from the preset value, the value in memory A or the value in memory B. (See page 113.) You can select the preset white balance at 3200 K or 5600 K using the FILTER control (3 on page 12). You can change the preset color temperature on basic menu page 2. (See page 81.)

9 MENU dial

Use this dial to change menu pages or settings.

10 POWER switch

Powers the camcorder on or off.

11 OUTPUT/DL/DCC+ (Color bar output/ DynaLatitude/dynamic contrast control plus) switch

Use this switch to select the DCC+ function, the DynaLatitude function, or color bar output. Select the CAM/DCC+ position in most cases.

CAM/DCC+: This activates the DCC+ function. This prevents color faults when shooting high-intensity subjects.

CAM/DL: This setting uses the DynaLatitude function, which finely adjusts the contrast of each pixel according to a histogram of luminance signal levels. Access advanced menu page 2 to set the DynaLatitude function ON or OFF. The DynaLatitude effect can be set to any of three levels, Low, STD (standard), and High with basic menu page 2.

BARS: This setting displays color bars.

For details of menu operation, see Chapter 4 “Viewfinder Screen Indications and Menus”.

12 NG button

When using the ClipLink function during shooting, you can designate a particular scene as “NG” (No Good) by pressing this button before shooting the next scene. Press the button again to cancel the NG setting.

13 GAIN switch

This selects one of the three gain settings, high, medium or low. You can choose the gain values assigned to the H, M and L settings from values from –3 dB to 24 dB + DPR, and hyper gain. (See page 88.) The factory default selections are 18 dB (H), 9 dB (M) and 0 dB (L).

Note

When the HYPER GAIN switch (7 on page 22) is in the ON position, the GAIN switch has no effect.

14 ATW (auto tracing white balance) button and indicator

Press this button, turning the indicator on, when you want the white balance to be adjusted automatically to follow changes in lighting conditions. (See page 114.)

Rear section

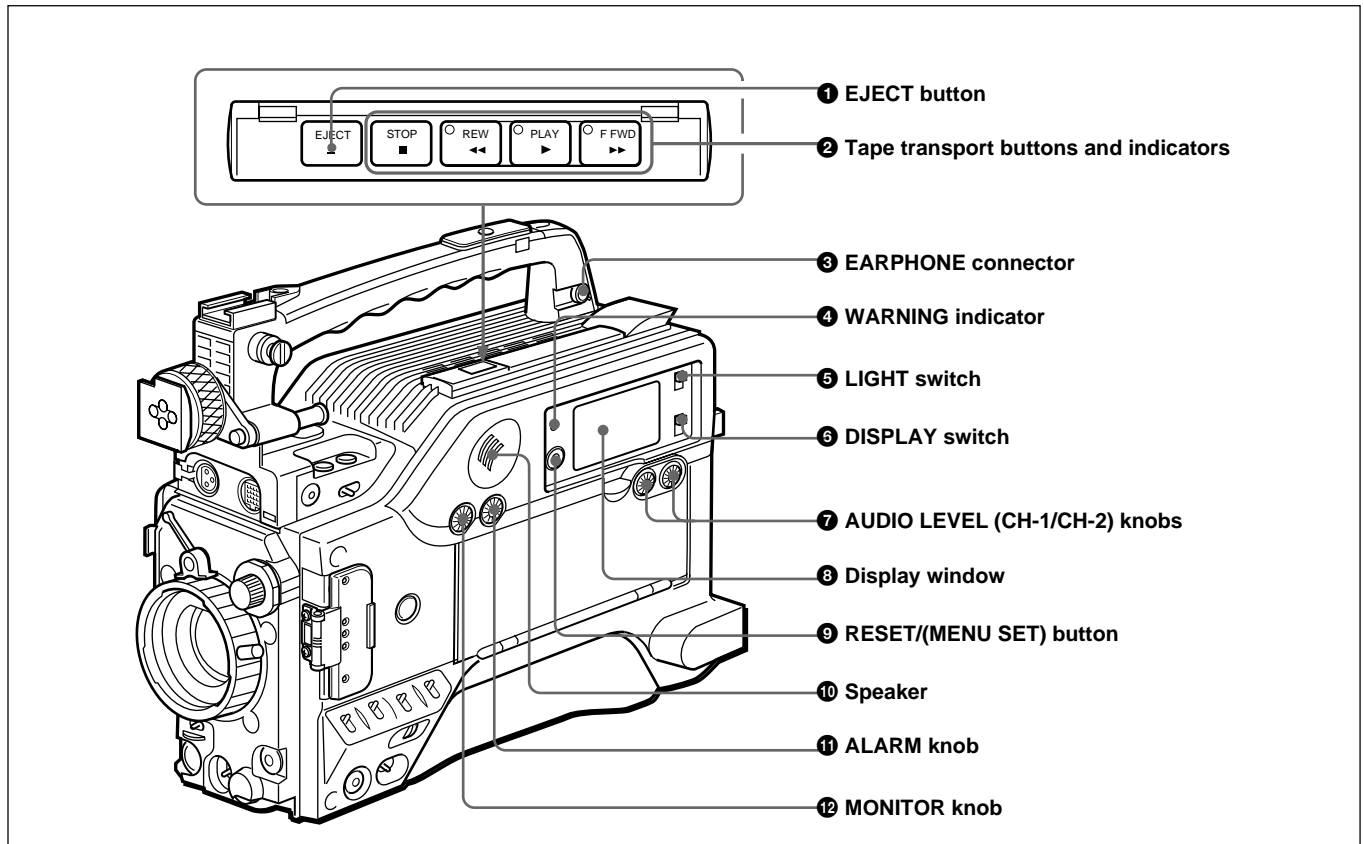

1 EJECT button

Press to open the cassette holder (1 on page 24) when the camcorder is powered.

2 Tape transport buttons and indicators

These buttons transport the tape as shown below.

Buttons	Operation
REW ◀◀	Rewinds the tape. The indicator lights while the tape is being rewound. Press while the tape is being rewound or during playback to view reverse search playback.
F FWD ▶▶	Fast forwards the tape. The indicator lights while the tape is being fast forwarded. Press while the tape is being fast forwarded or during playback to view forward search playback.
PLAY ▶	Plays back the recorded video. The indicator lights during playback.
STOP ■	Stops the tape.

Note

During recording, none of these buttons operates.

3 EARPHONE connector (mini-jack)

Connect an earphone or headphones. This outputs the sound which was output to the speaker (10 on page 18), but mutes the speaker.

4 WARNING indicator

This lights or blinks when an abnormality occurs.

For details, see "Warning System" on page 127.

5 LIGHT switch

This switches the display window (8 on page 16) light on or off.

6 DISPLAY switch

Switches time value indication shown in the display window (8 on page 16).

COUNTER: Shows the tape transport time in HH:MM:SS (hours, minutes and seconds).

TC: Shows the time code value.

U-BIT: Shows the user bit data in the time code.

Location and Function of Parts

7 AUDIO LEVEL (CH-1/CH-2) (audio recording level adjustments for channels 1 and 2) knobs

When the AUDIO SELECT (CH-1/CH-2) switches (4 on page 20) are set to MAN, these knobs adjust the audio levels being recorded on channels 1 and 2.

The audio levels are indicated in the display window 8. For details, see "8 Display window" below.

8 Display window

Shows the following items. Use the LIGHT switch (5 on page 15) to light up the display window.

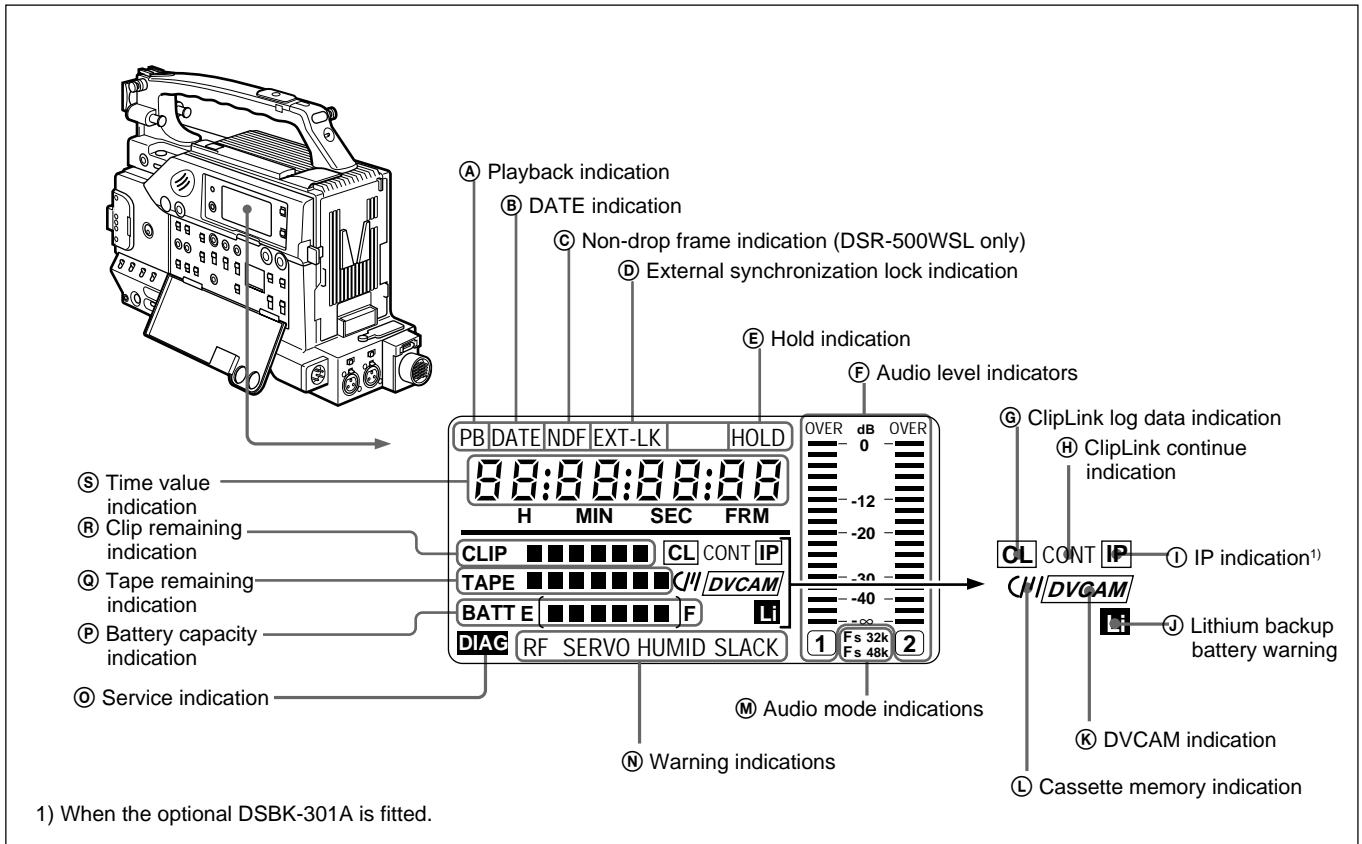

Indications in the display window

Indication	Description
A Playback indication	Appears during playback, fast forward or rewind with the time data display showing a time code or user bit value.
B DATE indication	Appears when the date or time is displayed in the time value indication S area.
C Non drop-frame indication (DSR-500WSL only)	Appears when non-drop frame mode is selected.
D External synchronization indication	Appears when the internal time code generator is locked to an external signal input to the TC IN connector (3 on page 24).
E Hold indication	Appears when the internal time code generator is stopped.
F Audio level indicators	These show the audio recording or playback levels of channel 1 and channel 2.
G ClipLink log data indication	Appears when using a cassette with cassette memory containing ClipLink log data.
H ClipLink continue indication	Appears when back space editing using ClipLink function is possible.
I IP(Index Picture) indication	Appears when the ClipLink function is set to on in the VCR menu and Index Picture recording is allowed. (The optional DSBK-301A is required.)

Indication	Description																													
Ⓛ Lithium backup battery warning	Appears when the voltage of the internal lithium backup battery (CR2032) is low. If this indication appears, replace the lithium backup battery immediately. <i>For further information about replacing lithium battery, see “Inserting and Replacing the Lithium Battery” (page 31).</i>																													
Ⓚ DVCAM indication	Disappears when the cassette being played back is not for DVCAM format.																													
Ⓛ Cassette memory indication	Appears when using a cassette with cassette memory.																													
Ⓜ Audio mode indications	These show audio recording/playback mode. Fs32k : 4-channel mode (32kHz sampling frequency) Fs48k : 2-channel mode (48kHz sampling frequency) <i>For further information about selecting audio recording mode, see “Menu 212 Selecting Audio Recording Mode” (page 109).</i>																													
Ⓝ Warning indications	Include the following. RF : Appears when the video heads are clogged, or when there is a fault in the recording system. SERVO : Appears when the servo lock is not functioning. HUMID : Appears when there is condensation on the drum. SLACK : Appears when there is a tape winding fault. <i>For measures against warning indications, see “Warning System” (page 127).</i>																													
Ⓞ Service indication	Appears during maintenance or VCR menu operations (page 103). It does not appear during normal operation.																													
Ⓟ Battery capacity indication	This indicates the battery capacity and voltage as shown below. Change menu setting for the battery you are using. <i>For menu settings, see “Menu 206 Selecting Battery Capacity Indication” (page 106).</i> <table border="1"> <thead> <tr> <th rowspan="2">Indication</th> <th colspan="2">Battery voltage</th> </tr> <tr> <th>BP-L40/L40A/L60/L60A/L90/L90A</th> <th>NP-1B/BP-90A</th> </tr> </thead> <tbody> <tr> <td>BATT E[■■■■■■■]F</td> <td>15.0 V or more</td> <td>12.5 V or more</td> </tr> <tr> <td>BATT E[■■■■■]]F</td> <td>14.0 to 15.0 V</td> <td>12.0 to 12.5 V</td> </tr> <tr> <td>BATT E[■■■■]]F</td> <td>13.0 to 14.0 V</td> <td>11.75 to 12.0 V</td> </tr> <tr> <td>BATT E[■■■]]F</td> <td>12.0 to 13.0 V</td> <td>11.5 to 11.75 V</td> </tr> <tr> <td>BATT E[■■]]F</td> <td>11.3 to 12.0 V</td> <td>11.3 to 11.5 V</td> </tr> <tr> <td>BATT E[■]]F (blinking)¹⁾</td> <td>11.25 to 11.3 V</td> <td>11.25 to 11.3 V</td> </tr> <tr> <td>BATT E[]]F (blinking)</td> <td>11.0 to 11.25 V</td> <td>11.0 to 11.25 V</td> </tr> <tr> <td>BATT E[]]F (blinking)</td> <td>11.0 V or less</td> <td>11.0 V or less</td> </tr> </tbody> </table> ¹⁾ Replace the battery pack when this indication appears.	Indication	Battery voltage		BP-L40/L40A/L60/L60A/L90/L90A	NP-1B/BP-90A	BATT E[■■■■■■■]F	15.0 V or more	12.5 V or more	BATT E[■■■■■]]F	14.0 to 15.0 V	12.0 to 12.5 V	BATT E[■■■■]]F	13.0 to 14.0 V	11.75 to 12.0 V	BATT E[■■■]]F	12.0 to 13.0 V	11.5 to 11.75 V	BATT E[■■]]F	11.3 to 12.0 V	11.3 to 11.5 V	BATT E[■]]F (blinking) ¹⁾	11.25 to 11.3 V	11.25 to 11.3 V	BATT E[]]F (blinking)	11.0 to 11.25 V	11.0 to 11.25 V	BATT E[]]F (blinking)	11.0 V or less	11.0 V or less
Indication	Battery voltage																													
	BP-L40/L40A/L60/L60A/L90/L90A	NP-1B/BP-90A																												
BATT E[■■■■■■■]F	15.0 V or more	12.5 V or more																												
BATT E[■■■■■]]F	14.0 to 15.0 V	12.0 to 12.5 V																												
BATT E[■■■■]]F	13.0 to 14.0 V	11.75 to 12.0 V																												
BATT E[■■■]]F	12.0 to 13.0 V	11.5 to 11.75 V																												
BATT E[■■]]F	11.3 to 12.0 V	11.3 to 11.5 V																												
BATT E[■]]F (blinking) ¹⁾	11.25 to 11.3 V	11.25 to 11.3 V																												
BATT E[]]F (blinking)	11.0 to 11.25 V	11.0 to 11.25 V																												
BATT E[]]F (blinking)	11.0 V or less	11.0 V or less																												

(Continued)

Location and Function of Parts

Indication	Description																														
ⓐ Tape remaining indication	<p>During recording or pause mode, this indication shows the remaining tape time as shown below. It is not displayed when no cassette is loaded.</p> <table border="1"> <thead> <tr> <th>Indication</th> <th>Tape time remaining</th> </tr> </thead> <tbody> <tr> <td>TAPE■■■■■■■■■■</td> <td>30 minutes or more</td> </tr> <tr> <td>TAPE■■■■■■■</td> <td>25 to 30 minutes</td> </tr> <tr> <td>TAPE■■■■■■</td> <td>20 to 25 minutes</td> </tr> <tr> <td>TAPE■■■■■</td> <td>15 to 20 minutes</td> </tr> <tr> <td>TAPE■■■■</td> <td>10 to 15 minutes</td> </tr> <tr> <td>TAPE■■■</td> <td>5 to 10 minutes</td> </tr> <tr> <td>TAPE■■</td> <td>2 to 5 minutes</td> </tr> <tr> <td>TAPE■ (blinking)</td> <td>0 to 2 minutes</td> </tr> <tr> <td>TAPE (blinking)</td> <td>End of tape</td> </tr> </tbody> </table>	Indication	Tape time remaining	TAPE■■■■■■■■■■	30 minutes or more	TAPE■■■■■■■	25 to 30 minutes	TAPE■■■■■■	20 to 25 minutes	TAPE■■■■■	15 to 20 minutes	TAPE■■■■	10 to 15 minutes	TAPE■■■	5 to 10 minutes	TAPE■■	2 to 5 minutes	TAPE■ (blinking)	0 to 2 minutes	TAPE (blinking)	End of tape										
Indication	Tape time remaining																														
TAPE■■■■■■■■■■	30 minutes or more																														
TAPE■■■■■■■	25 to 30 minutes																														
TAPE■■■■■■	20 to 25 minutes																														
TAPE■■■■■	15 to 20 minutes																														
TAPE■■■■	10 to 15 minutes																														
TAPE■■■	5 to 10 minutes																														
TAPE■■	2 to 5 minutes																														
TAPE■ (blinking)	0 to 2 minutes																														
TAPE (blinking)	End of tape																														
ⓑ Clip remaining indication	<p>This shows how many clip shots or Cue points can be recorded¹⁾.</p> <table border="1"> <thead> <tr> <th>Indication</th> <th>Clip shots</th> <th>Cue point</th> </tr> </thead> <tbody> <tr> <td>CLIP■■■■■■■■</td> <td>51 or more</td> <td>101 points or more</td> </tr> <tr> <td>CLIP■■■■■■■</td> <td>41 to 50</td> <td>81 to 100 points</td> </tr> <tr> <td>CLIP■■■■■■</td> <td>31 to 40</td> <td>61 to 80 points</td> </tr> <tr> <td>CLIP■■■■■</td> <td>21 to 30</td> <td>41 to 60 points</td> </tr> <tr> <td>CLIP■■■■</td> <td>11 to 20</td> <td>21 to 40 points</td> </tr> <tr> <td>CLIP■■■</td> <td>1 to 10</td> <td>1 to 20 points</td> </tr> <tr> <td>CLIP■ (blinking)²⁾</td> <td>1 to 3</td> <td>1 to 6 points</td> </tr> <tr> <td>CLIP</td> <td>Cannot record</td> <td></td> </tr> <tr> <td>CLIP (blinking)²⁾</td> <td>Cannot record</td> <td></td> </tr> </tbody> </table> <p>1) The optional DSBK-301A is required for Index Picture recording. 2) When back space editing using ClipLink function is possible (when CONT is displayed).</p>	Indication	Clip shots	Cue point	CLIP■■■■■■■■	51 or more	101 points or more	CLIP■■■■■■■	41 to 50	81 to 100 points	CLIP■■■■■■	31 to 40	61 to 80 points	CLIP■■■■■	21 to 30	41 to 60 points	CLIP■■■■	11 to 20	21 to 40 points	CLIP■■■	1 to 10	1 to 20 points	CLIP■ (blinking) ²⁾	1 to 3	1 to 6 points	CLIP	Cannot record		CLIP (blinking) ²⁾	Cannot record	
Indication	Clip shots	Cue point																													
CLIP■■■■■■■■	51 or more	101 points or more																													
CLIP■■■■■■■	41 to 50	81 to 100 points																													
CLIP■■■■■■	31 to 40	61 to 80 points																													
CLIP■■■■■	21 to 30	41 to 60 points																													
CLIP■■■■	11 to 20	21 to 40 points																													
CLIP■■■	1 to 10	1 to 20 points																													
CLIP■ (blinking) ²⁾	1 to 3	1 to 6 points																													
CLIP	Cannot record																														
CLIP (blinking) ²⁾	Cannot record																														
ⓒ Time value indication	<p>Depending on the DISPLAY switch (Ⓔ on page 15) setting, this shows a counter value, time code value or user bit value. Press the MENU button (Ⓐ on page 19) to display the VCR menu.</p>																														

Ⓓ RESET/(MENU SET) (counter reset/VCR menu) button

Resets the time value shown in the display window. This button operates differently depending on settings of the DISPLAY switch (Ⓔ on page 15), and the TC mode switches 1 (Ⓒ on page 20) and 2 (Ⓖ on page 20).

Switch setting	RESET button operation
DISPLAY: COUNTER	Resets counter value to 0:00:00.
DISPLAY: TC TC mode switch 1: PRESET TC mode switch 2: SET	Resets time code to 00:00:00:00.
DISPLAY: U-BIT TC mode switch 1: PRESET TC mode switch 2: SET	Resets user bit ^{a)} to 00 00 00 00.

a) Bits of time code recorded on tape, in which users can record necessary information.

Also, this button is used to change VCR menu settings.

For details on the VCR menu, see “Setting on the VCR Section —VCR Menu” (page 103).

Ⓙ Speaker

Outputs the recorded or playback audio. When a warning indicator appears in the viewfinder or display window, the speaker sounds a warning tone. The speaker is muted (does not output a warning tone) when an earphone is connected to the EARPHONE connector (Ⓒ on page 15).

For details on the warning tone, see “Warning System” (page 127).

11 ALARM (alarm tone volume adjustment) knob
Controls the volume of the warning tone that is output via the speaker (10 on page 18) or the EARPHONE connector (3 on page 15). Turning this knob to the minimum setting mutes the alarm tone.

12 MONITOR (monitor volume adjustment) knob
Controls the volume of the sound other than the warning tone that is output via the speaker (10 on page 18) or the EARPHONE connector (3 on page 15). Turning this knob to the minimum setting mutes the audio output.

Operation panel under the cover

Right side

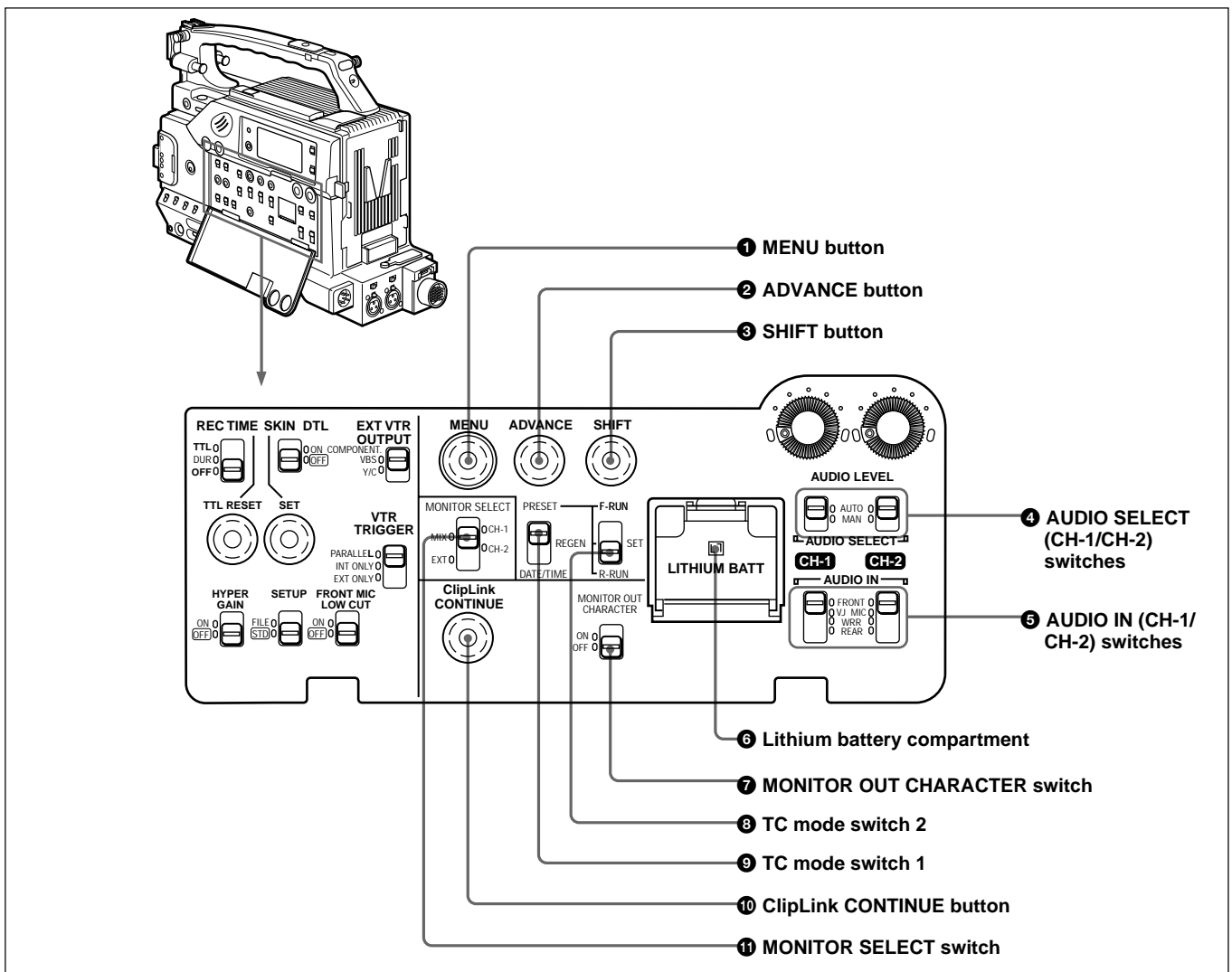

1 MENU button

Press this button to display the VCR menu in the display window.

For details about the VCR menu, see “Setting on the VCR Section —VCR Menu” (page 103).

2 ADVANCE button

When setting time code and user bit values, or at menu setting, press this button to increment the digit that has

been selected with the SHIFT button (3 on page 20). In other case, keep pressing this button to show the clip remaining indication instead of time value. (Example: CLIP 045)

For time code and user bit settings, see pages 62 to 65.

On how to use the ADVANCE button for menu settings, see “Setting on the VCR Section —VCR Menu” (page 103).

Location and Function of Parts

③ SHIFT button

When setting time code and user bit values, or at menu setting, keep pressing this button to select a digit. The selected digit will start blinking.

In other case, keep pressing this button to show the date (when the DISPLAY switch (⑥ on page 15) is set to U-BIT) and time (when the DISPLAY switch is set to TC) instead of time value.

For time code and user bit settings, see pages 62 to 65.

On how to use the SHIFT button for menu settings, see “Setting on the VCR Section —VCR Menu” (page 103).

④ AUDIO SELECT (CH-1/CH-2) (audio recording level adjustments manual/auto selection for channels 1 and 2) switches

These select the audio recording level adjustment method.

AUTO: Use the AGC (automatic gain control) circuit to automatically adjust the audio level.

MAN(MANUAL): Enables users to manually adjust the AUDIO LEVEL (CH-1/CH-2) knobs (⑦ on page 16) for each channel. Select AUTO if excess input levels are likely to occur.

⑤ AUDIO IN (CH-1/CH-2) (audio input selection for channels 1 and 2) switches

These select the input signals to channels 1 and 2.

FRONT: Signals from the microphone connected to the MIC IN +48 V connector (① on page 12).

VJ MIC: Signals from the remote control unit with microphone connected to the REMOTE connector 2 (⑪ on page 24).

WRR: Signals from the WRR-855A synthesized tuner connected to the WRR connector (⑥ on page 26) via the CA-WR855 Camera Adaptor.

REAR: Signals from a microphone or external equipment connected to the AUDIO IN (CH-1/CH-2) connectors (⑤ on page 26).

⑥ Lithium battery compartment

Insert the supplied CR2032 Lithium Battery.

On how to fit the lithium battery, see page 31.

⑦ MONITOR OUT (monitor output) CHARACTER switch

Set ON to superimpose text information on the monitor output.

Note

Set this switch ON when using the freeze mix function.

⑧ TC (time code) mode switch 2

Sets the mode for advancing time code values when the TC mode switch 1 ⑨ has been set to PRESET.

F-RUN: The time code advances continuously whether or not the camcorder is recording. Use this setting to align the time code value with real time.

SET: Use this setting to set the time code or user bit value.

R-RUN: The time code value advances only during recording. Use this setting to have consecutive recordings on the tape.

Note for the DSR-500WSL

There are two time code frame modes: drop-frame (DF) mode and non drop-frame (NDF) mode. This product is shipped with drop-frame mode selected.

For details on switching between drop-frame mode and non drop-frame mode, see “Selecting Frame Mode (DF/NDF) for Time Code (for DSR-500WSL Only) —Menu 204” (page 105).

For details on drop-frame mode and non drop-frame mode, see “Drop-frame mode (for DSR-500WSL only)” on page 65.

⑨ TC (time code) mode switch 1

Selects between resetting the time code value or continuing from the time code value at the end of the previous recording.

PRESET: This starts recording time code values on the tape from the currently set value.

REGEN: During back space editing, this reads the tape's current time code value and sets the time code to record starting from that value. The time code value is advanced in R-RUN mode regardless of the setting on TC mode switch 2 ⑧.

DATE/TIME: This synchronizes the time code to the real time clock set in the VCR menu (see page 105). In this case the time code of the DSR-500WSL is recorded in DF (drop-frame mode).

Note

If the ClipLink function is set to on (meaning ClipLink shooting is allowed) in menu 211 and **CONT** is displayed in the display window, regardless of the setting of this switch, the time code generator automatically enters the REGEN mode at recording. (The ClipLink function is set to OFF at factory.) When you will not perform ClipLink shooting, set the ClipLink function to OFF (see page 109).

10 ClipLink CONTINUE button

When restart ClipLink shooting, press this button to add the new clip at the end of the recorded clips.

Note

When restart recording without pressing this button, the pre-recorded ClipLink log data and Index Pictures are deleted.

For details, see "ClipLink Shooting" (page 68).

11 MONITOR SELECT (audio monitor selection) switch

Selects audio output via the speaker (10 on page 18) or earphone.

CH-1: Channel 1 audio

MIX: Mixed audio (channels 1 and 2)

CH-2: Channel 2 audio

EXT: The sound selected by an external VCR connected to the VTR connector (10 on page 26)

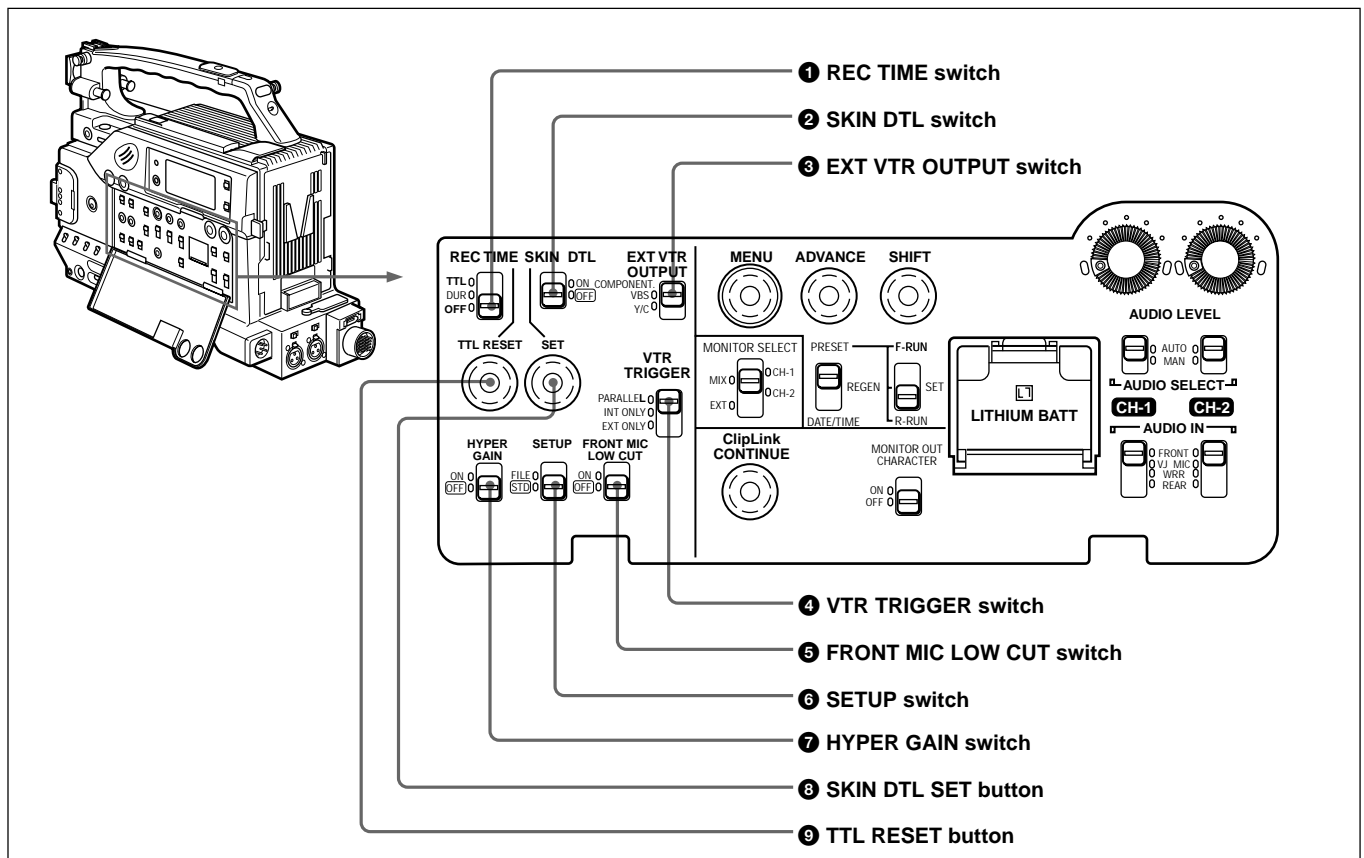
Left side**1 REC (recording) TIME switch**

Selects the recording time indication in the viewfinder.

TTL (TOTAL): Displays the total recording time.

The total recording time is not reset even when you stop the VCR and power off the camcorder, for example, to replace the battery pack.

DUR (DURATION): Displays the recording time of the current cut.

OFF: Switches off the recording time display.

If, however, in advanced menu page 6 you set the time code display item (TC IND) to ON (see page 90), then the VCR time data (time code, counter, or user bit value) is displayed.

(Continued)

Location and Function of Parts

Note

The recording time displayed when this switch is set to TTL or DUR is obtained by counting the duration of the internal reference signal input to the camcorder. The value may not agree exactly with the value derived from the time code values. Furthermore, the value displayed may not be correct when another manufacture's VCR is connected to the camcorder.

② SKIN DTL (skin detail) switch

Set this switch ON to use the skin detail correction function.

For details, see "Skin Detail Correction" (page 123).

③ EXT VTR OUTPUT switch

Depending on the external VCR connected to the VTR connector (⑩ on page 26), this switches the video signal output to the VCR.

COMPONENT/VBS: Component/composite video signal

Y/C: S-video signal

④ VTR TRIGGER switch

Sets the function of the VTR button on the camcorder or lens when a VCR is connected to the VTR connector (⑩ on page 26).

PARALLEL: Operates both internal and external VCRs.

INT ONLY: Operates the internal VCR only.

External VCR operation is performed locally.

EXT ONLY: Operates the external VCR only.

⑤ FRONT MIC LOW CUT switch

Set this switch to ON to insert a high-pass filter in the microphone circuit, reducing wind noise.

Normally leave the switch in the OFF position.

⑥ SETUP switch

Use this switch to select the camcorder setup method.

FILE: Set up using setup files and the setup menu.

STD: Set up using the setup menu. Setup file data is not displayed.

⑦ HYPER GAIN switch

Setting this switch to the ON position increases the gain by a factor of about 60 or 120 with respect to 0 dB (a 30 or 36 dB increase by electronic amplification and a 6 dB increase for DPR, bringing about a total gain increase of 36 or 42 dB).

When this switch is in ON position, the indication "HYPER" appears in the viewfinder, and the GAIN UP indicator in the viewfinder also lights.

When finished shooting, return this switch to OFF position. The HYPER indication disappears and the GAIN UP indicator goes out.

Note

Increasing the gain with this switch reduces the horizontal resolution by approx. 50%.

⑧ SKIN DTL (skin detail) SET button

Press this button with the SKIN DTL switch ② has been set to ON to display the area detect cursor on viewfinder screen. Place the cursor on the target and press this button to perform skin detail correction.

For details, see "Skin Detail Correction" (page 123).

⑨ TTL (total) RESET button

Pressing this button resets the total recording time (TTL selection) to 0.

Left and Upper View

Front section

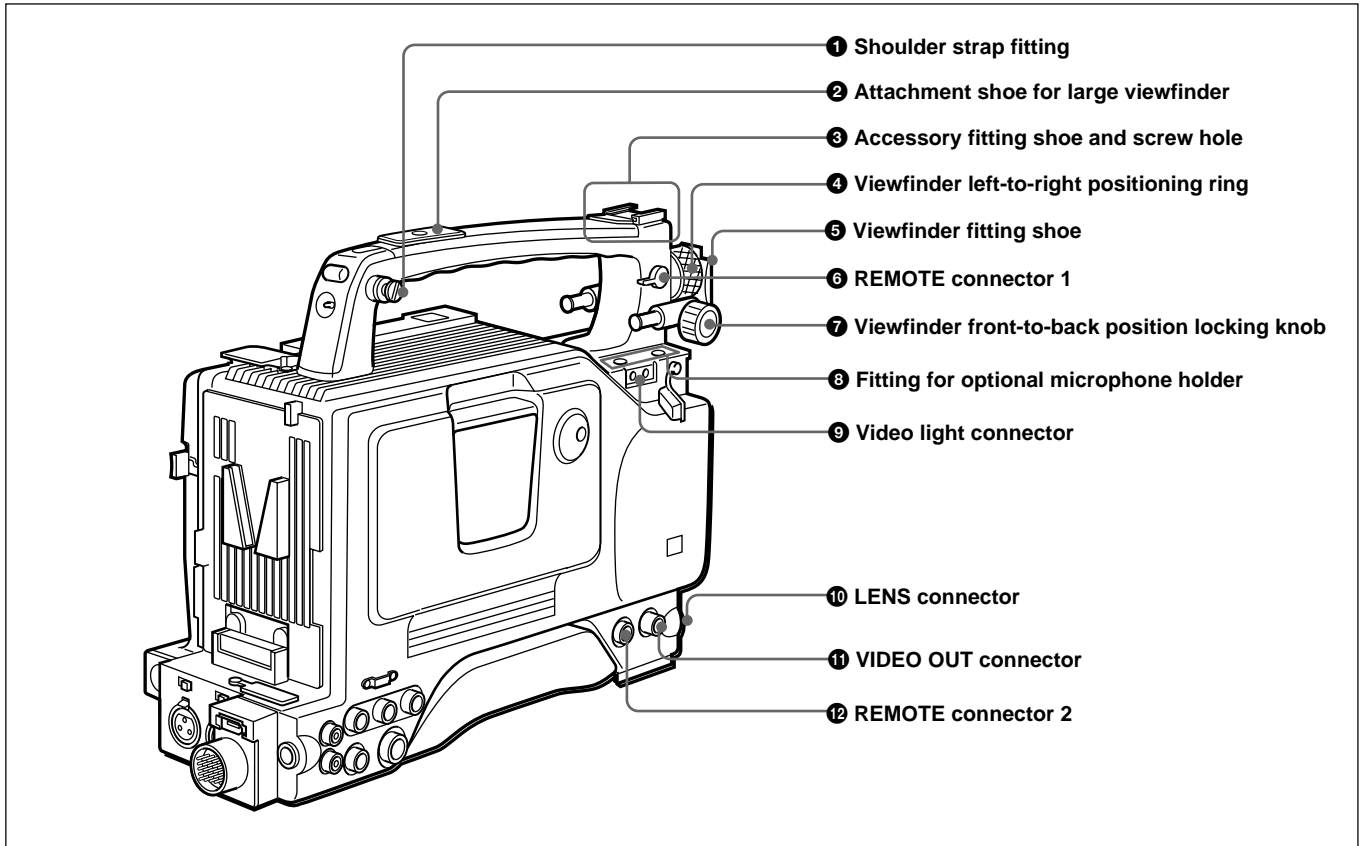

❶ Shoulder strap fitting

To use the supplied shoulder strap, fix one end here and the other end to the right side. (See page 38.)

❷ Attachment shoe for large viewfinder

This allows you to attach the optional electronic viewfinder. (See page 35.)

❸ Accessory fitting shoe and screw hole

Attach optional video lights or other accessories here. (See page 37.)

❹ Viewfinder left-to-right position fixing ring

Loosen this ring to adjust the left-to-right position of the viewfinder. (See page 34.)

❺ Viewfinder fitting shoe

Fix the DXF-801/801CE Viewfinder here. (See page 34.)

❻ REMOTE connector 1 (mini-jack)

Connect the RM-LG1 Remote Control Unit to enable remote operation of the ClipLink function.

❶ Shoulder strap fitting

❷ Attachment shoe for large viewfinder

❸ Accessory fitting shoe and screw hole

❹ Viewfinder left-to-right positioning ring

❺ Viewfinder fitting shoe

❻ REMOTE connector 1

❼ Viewfinder front-to-back position locking knob

❽ Fitting for optional microphone holder

❾ Video light connector

❿ LENS connector

⓫ VIDEO OUT connector

⓬ REMOTE connector 2

If you connect the optional cable (Sony part number: 1-790-779-11) to this connector, you can control the zoom using the optional RM-VJ1 Remote Control Unit (equipped with microphone and monitor), even if you use the conventional lens.

For details, consult your Sony dealer.

Note

The RM-81 cannot be connected.

❼ Viewfinder front-to-back position locking knob

Loosen this knob to adjust the front-to-back position of the viewfinder. (See page 34.)

❽ Fitting for optional microphone holder

You can fit an optional CAC-12 Microphone Holder here. (See page 36.)

❾ Video light connector

A video light with a maximum power consumption of 30 W such as the Anton Bauer Ultralight 2 or equivalent can be connected. (See page 37.)

Location and Function of Parts

⑩ LENS connector (12-pin)

Connect the lens cable.

⑪ VIDEO OUT connector (BNC)

This outputs the video signal captured by the camcorder.

⑫ REMOTE connector 2 (10-pin)

Connect the optional RM-M7G Remote Control Unit to this connector. Set the CAMERA SELECT switch on the bottom of RM-M7G to 1.

You can also connect the RM-VJ1 Remote Control Unit (equipped with microphone and monitor.)

Notes

- EZ mode cannot be used if the RM-M7G is connected to the camcorder.
- Be sure to turn off the power of the camcorder before connecting the RM-M7G/VJ1.
- Be sure to turn off the power of the camcorder before disconnecting the equipment connected to this connector. Otherwise, the camcorder will not work properly.

Rear section

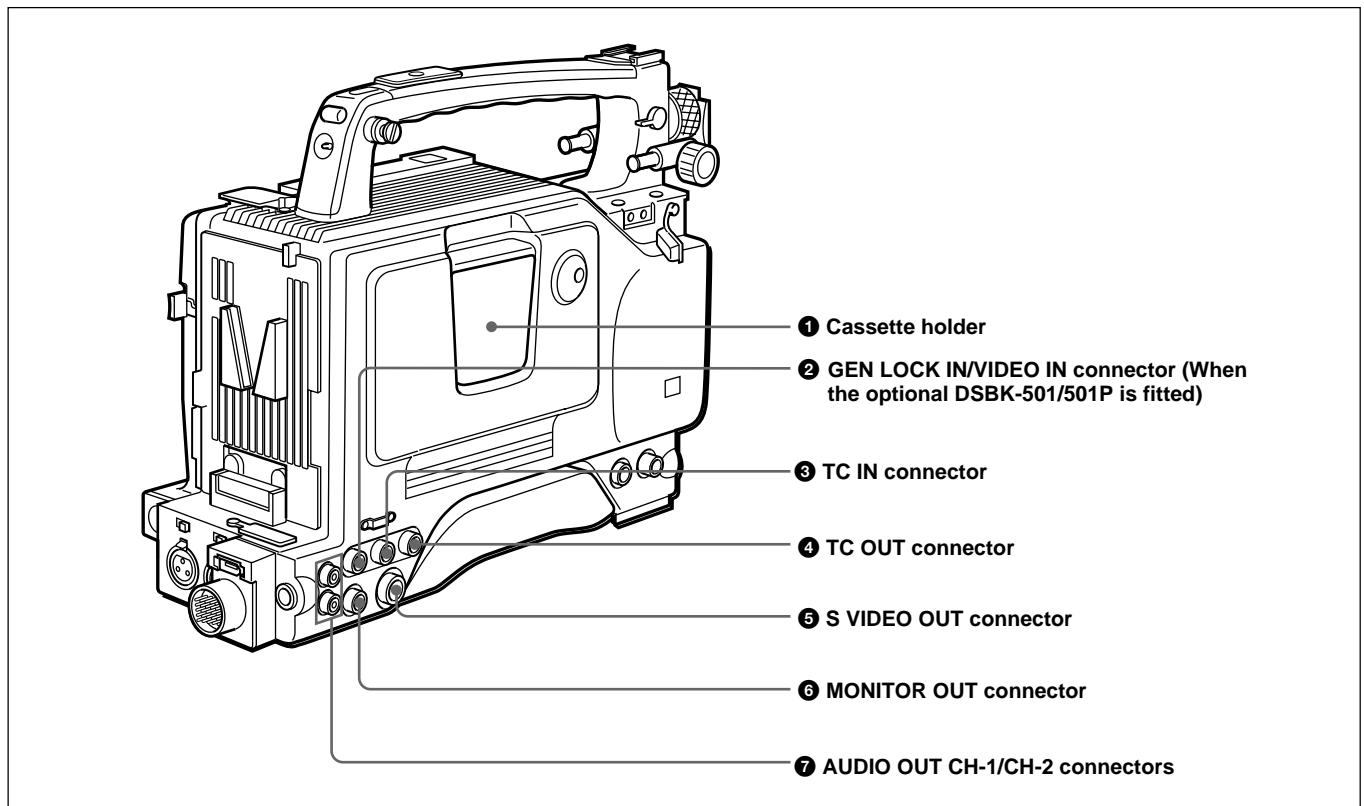

① Cassette holder

Power the camcorder and press the EJECT button to open the lid. Insert the cassette and close the lid by pressing the indication "PUSH".

② GEN LOCK IN (gen lock video input)/VIDEO IN (video input) connector (When the optional DSBK-501/501P is fitted) (BNC)

GEN LOCK IN: When synchronizing the camcorder to an external signal, input a reference video signal (VBS or BS). (See page 81.)

VIDEO IN:

When the optional DSBK-501/501P Analog Composite Input Board is fitted to the camcorder, you can input the analog video signals (VBS) to this connector.

③ TC IN (time code input) connector (BNC)

Input an external signal for synchronizing the built-in time code generator. Use an SMPTE (DSR-500WSL) or EBU (DSR-500WSPL) time code signal.

Note

Use a jitterless LTC signal. Using an LTC signal reproduced by other equipment may cause the camcorder to malfunction.

4 TC OUT (time code output) connector (BNC)

This outputs time code signals from the built-in time code generator. When a time code signal is input to the TC IN connector (**3** on page 24), this output signal is synchronized to it.

For details about time code, see "Setting Time Values" on page 62.

5 S VIDEO OUT (S-video output) connector (DIN 4-pin)

This outputs the image being shot or played back as S-video signals. Connect to the S-video input connector

on an external VCR or video monitor.

6 MONITOR OUT (output) connector

Outputs the image being shot or played back as composite video signals. Connect to the video input connector on an external VCR or video monitor.

Note

The output signal from this connector may discontinue when switching the operation between recording and playback. Do not use as a reference video signal for external equipment.

7 AUDIO OUT CH-1/CH-2 (audio output channel 1 and 2) connectors (phono jacks)

These output the sound being recorded or played back. Connect to a stereo amplifier or video monitor's audio input connectors.

Rear and Bottom

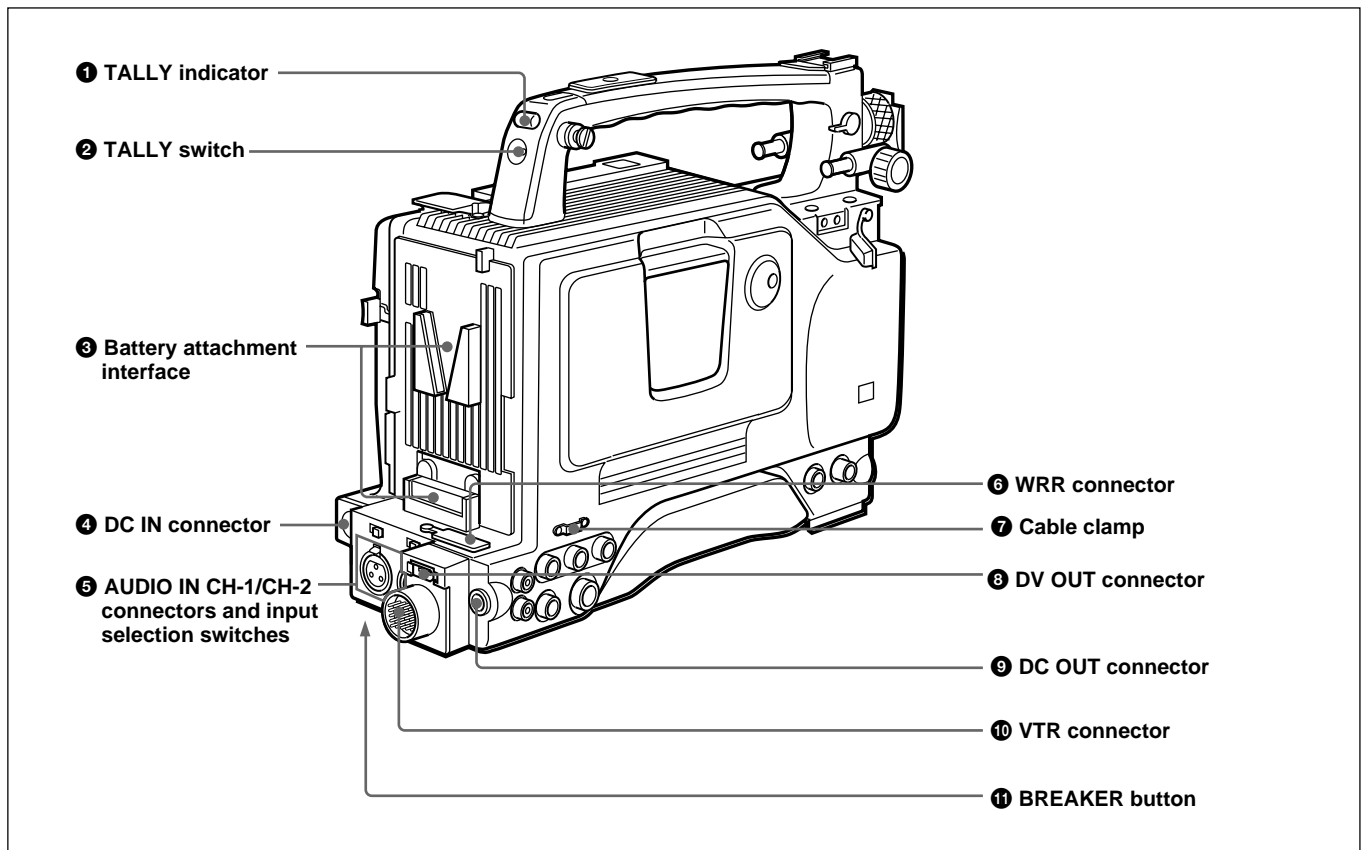
**1 TALLY (back tally) indicator (red)**

This indicator lights during recording. It will not light if the TALLY switch **2** is set to OFF. This indicator also blinks to indicate warnings in the same manner as the REC/TALLY indicator in the viewfinder.

2 TALLY switch

Set this switch to ON to activate the TALLY indicator **1** function.

For details, see "Warning System" on page 127.

Location and Function of Parts

3 Battery attachment interface

Attach a battery pack or an AC-DN1/DN2A, AC Adaptor. When using the WRR-855A synthesized tuner (for wireless microphones), attach the CA-WR855 Camera Adaptor here.

For information about fitting a battery pack or an AC adaptor, see "Power Supply" (page 46). For information about attaching a synthesized tuner, see "Connecting to Audio System" (page 39).

4 DC IN (DC power input) connector (XLR 4-pin, male)

To use the camcorder with an AC power supply, connect an optional AC-550/550CE or CMA-8A/8ACE AC Adaptor.

5 AUDIO IN CH-1/CH-2 (audio input channel 1 and 2) connectors (XLR 3-pin, female) and input selection switches

Connect a microphone or other external audio equipment. Set the input selection switches as shown below according to the microphone or equipment.

MIC+48V ON (right position): For connecting to a 48-V microphone

Note

If this position is selected for a microphone other than 48-V microphone, the microphone may be damaged.

MIC (center position): For connecting any microphone other than 48-V microphone

LINE (left position): For connecting an external audio signal source such as a stereo amplifier.

6 WRR (synthesized tuner) connector (7-pin)

Insert the WRR-855A synthesized tuner into the CA-WR855 Camera Adaptor and connect the CA-WR855 here.

For information about attaching a synthesized tuner, see "Connecting to Audio System" (page 39)

7 Cable clamp

Fasten an i.LINK cable (DV connecting cable) to the clamp using the supplied binding tie so that the plug is not pulled out.

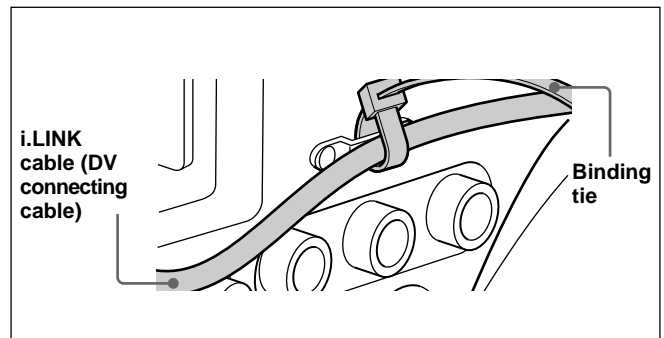

8 DV OUT connector (6-pin)

Connect to the DV input connector of an external VCR.

Notes

- This connector will not work as an input connector.
- When an external equipment, such as VCR, is connected to this connector, the ClipLink and the audio fade-in/fade-out function during recording will not work.

9 DC OUT (DC power output) connector (4-pin, female)

This connector supplies power for a WRR-810A/860A UHF Portable Tuner.

10 VTR connector (26-pin, male)

Connect an external VCR.

Notes

- This connector always outputs the signals from the camera. It is impossible to output the playback video of the internal VCR.
- A camera control unit (CCU) cannot be connected to this connector.
- The image size on the viewfinder or on the screen of the RM-VJ1 will not be switched automatically, even if the aspect ratio (16:9/4:3) of the return signal, input from an external VCR, is switched.

11 BREAKER (breaker reset) button

If an excessive current flows in the internal circuits, the internal circuit breaker shuts off the power supply. Push this button after eliminating the cause of the excessive current.

VCL-918BY Zoom Lens (not supplied)

When using a lens other than VCL-918BY, see page 121
("Designating the lens").

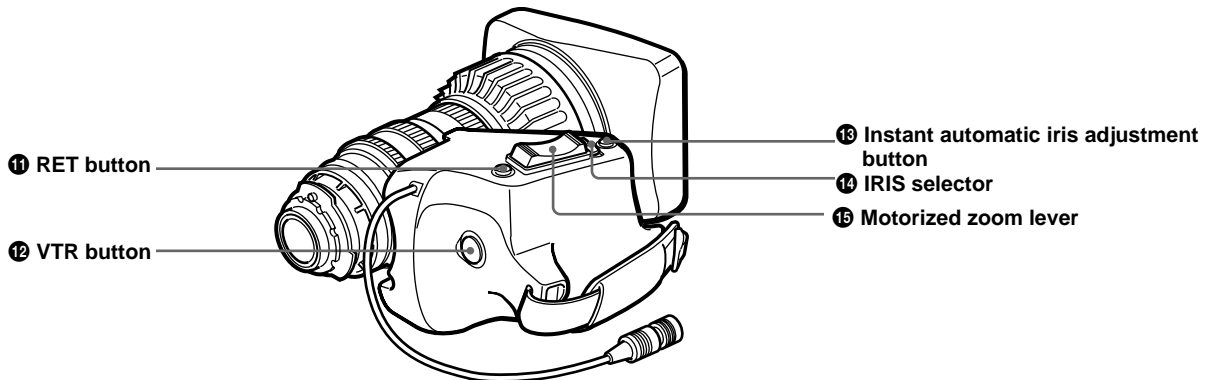
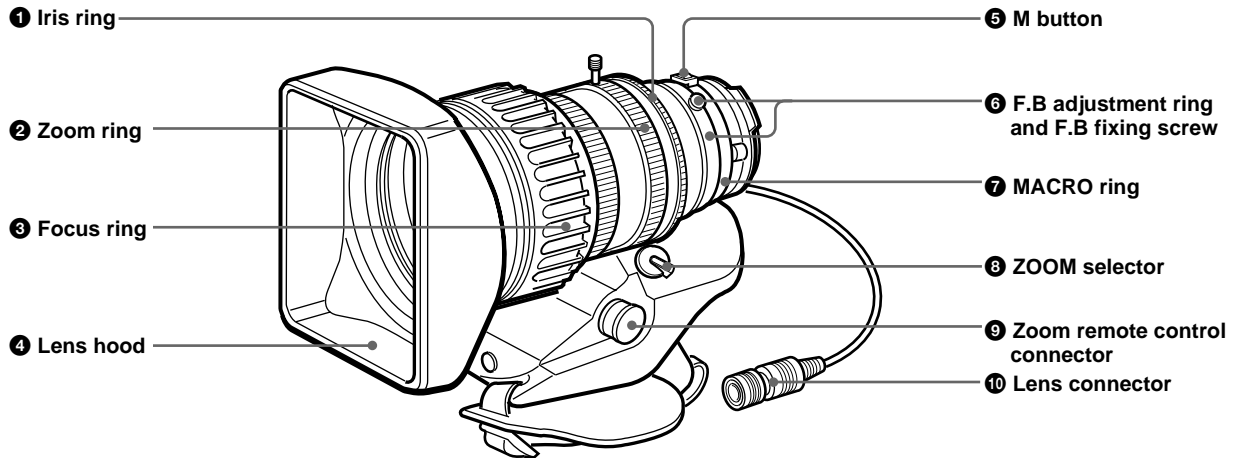

Location and Function of Parts

1 Iris ring

For manual iris control, set the IRIS selector to the “M” position, and turn this ring.

2 Zoom ring

For direct manual zoom control, set the ZOOM selector to the “MANU.” position, and turn this ring.

3 Focus ring

Turn this ring to focus the lens on the subject.

4 Lens hood

5 M (close-up) button

For close-up work, turn the MACRO ring while holding this button down. (See page 121.)

6 F.B (flange focal length) adjustment ring and F.B (flange focal length) fixing knob

F.B (flange focal length) adjustment ring : To adjust the flange focal length, loosen the F.B fixing knob, then turn the ring. (See page 119.)

F.B (flange focal length) fixing knob: Fixes the F.B adjustment ring.

7 MACRO (close-up) ring

For close-up, turn this ring while holding the M button down. (See page 121.)

8 ZOOM selector

This selects the mode of zoom operation.

SERVO: power zoom

MANU. (manual): manual zoom

9 Zoom remote control connector (8-pin)

Connect the optional LO-26 lens remote control unit for remote control of zooming.

When connecting the optional lens cable (Sony product number: 1-790-779-11) to this connector, you can control the zoom from the RM-VJ1 Remote Control Unit (equipped with microphone and monitor). (See page 41.)

10 Lens connector (12-pin)

Connect to the LENS connector (9 on page 24) of the camcorder.

11 RET (return) button

This allows you to check the video signal as follows. When the internal VCR is in recording pause mode, press this button to review the last few seconds of the recording in the viewfinder (recording review). When an external VCR is connected, pressing this button connects the E-E video signal¹⁾ from the external VCR to the viewfinder while the internal VCR is recording or no tape is inserted in the internal VCR.

For details, see “Playback — Checking Recorded Contents” (page 61).

12 VTR button

This button starts and stops recording on the VCR. Press it once to start recording, and once more to stop.

13 Instant automatic iris adjustment button

While using manual iris control, press this button to switch temporarily to the automatic iris control setting. The automatic setting is maintained as long as you hold the button down.

14 IRIS selector

This selects the mode of iris operation. (See page 14.)

A (automatic): automatic iris

M (manual): manual iris

15 Motorized zoom lever

Use this to carry out a power zoom. Pressing the lever harder increases the zoom speed.

W end: zoom toward wide angle

T end: zoom toward telephoto

1) **E-E video signal:** “electric-to-electric” video signal. This is the input video signal which has passed through internal electrical circuits, but has not been converted to a magnetic signal.

DXF-801/801CE Viewfinder

Note

You can switch the scan size of the DXF-801/801CE

in accordance with the aspect ratio selected on the camera or camcorder.

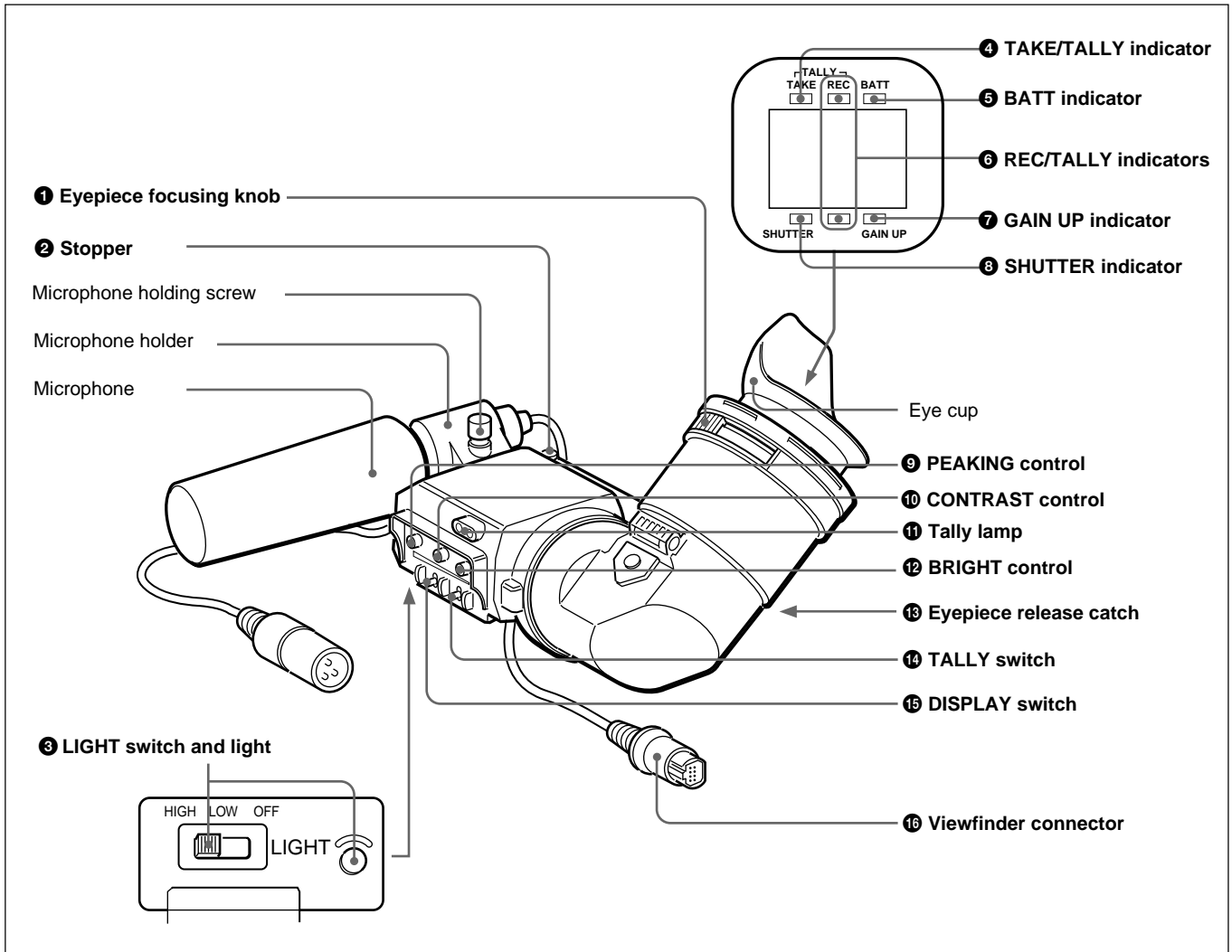

1 Eyepiece focusing knob

Turn this to adjust the viewfinder focus to match your eyesight. (See page 118.)

2 Stopper

Lift up when detaching the viewfinder (See page 34).

3 LIGHT switch and light

The light lights the lens and the switch controls the light as follows.

HIGH/LOW: Turn the light on and control the brightness.

OFF: Turns the light off.

4 TAKE/TALLY indicator (orange)

When using the ClipLink function while shooting, this indicator lights when the TAKE button (**6** on page 12) has been pressed to set a Mark IN point and goes out when a Mark OUT point is set.

5 BATT (battery) indicator (red)

This indicates when the battery capacity is low.

Location and Function of Parts

⑥ REC/TALLY (recording/tally) indicators (red)

- From the time when you press the VTR button (⑨ on page 12 and ⑫ on page 28) on the lens (not supplied) or camcorder, this flashes until recording starts, then stays on continuously during recording.
- This is also used to indicate a fault. (See page 127.)
- The lower indicator can be disabled by menu setting. (See page 89.)

⑦ GAIN UP indicator (orange)

This lights when the gain is 3 dB or more.

⑧ SHUTTER indicator (red)

This lights when the SHUTTER switch (⑤ on page 12) is in the ON position. (If the EVS is selected, the indicator will not light.)

⑨ PEAKING control

This adjusts the outline intensity of the viewfinder image. (See page 118.)

⑩ CONTRAST control

This adjusts the contrast of the viewfinder image. (See page 118.)

⑪ Tally lamp

When the TALLY switch ⑭ is in the HIGH or LOW position, this operates in the same way as the REC/TALLY indicators ⑥.

⑫ BRIGHT (brightness) control

This adjusts the brightness of the viewfinder image. (See page 118.)

⑬ Eyepiece release catch

To view the viewfinder screen directly, press this catch, and hinge up the eyepiece.

⑭ TALLY switch

When using the Tally lamp ⑪, this switch controls it as follows.

HIGH/LOW: Turn the light on and control the brightness.

OFF: Turns the light off.

⑮ DISPLAY switch

Set this switch to OFF when you want to remove the character data from the viewfinder and the monitor connected to the MONITOR OUT connector. However, items which are set to OFF in advanced menu page 5 and page 6 are not displayed even when this switch is set to ON.

⑯ Viewfinder connector (20-pin)

Connect this to the VF connector (② on page 12).

Inserting and Replacing the Lithium Battery

The camcorder uses a lithium battery to retain stored data. When using the camcorder for the first time, **be sure to insert the supplied lithium battery (CR2032)**. The camcorder will not operate correctly without this lithium battery.

Lifetime of the lithium battery

When the lithium battery's voltage falls, the lithium backup battery warning **Li** appears in the display window. If this warning appears, replace the lithium battery (CR2032) **within three or four days**.

The lithium battery has an average service life of about two years, however operation with the optional DSBK-301A in ClipLink mode will shorten the lifetime until about one year.

Inserting or replacing the lithium battery

Notes

- Carefully read the instructions for inserting and replacing the lithium battery. **Lithium batteries may explode if misused.**
- Use only CR2032 Lithium Batteries. Other types of lithium batteries may come loose when the camcorder is moved. If you have difficulty finding CR2032 Lithium Batteries, contact your Sony dealer.

1 Turn the POWER switch on.

2 Press down the catch at the top of the battery cover and open the cover.

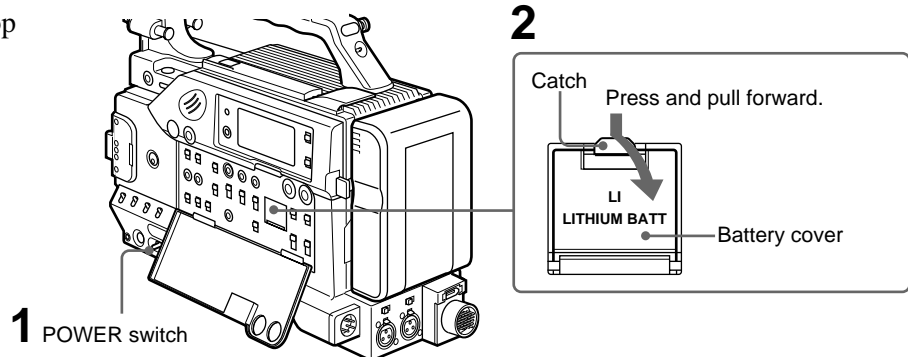

3 Take out the lithium battery.

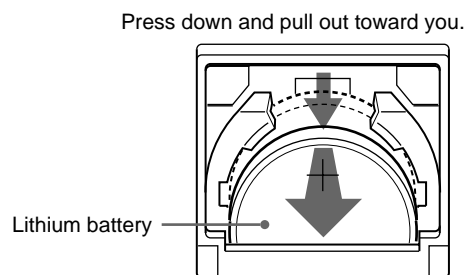

4 Reverse step 3 to insert a replacement lithium battery. Make sure that the **+ symbol on the battery is facing you**.

5 Close the battery cover.

Fitting the Lens

Note

Be sure to turn off the power before fitting the lens.

- 1 Remove the retaining rubber which prevents the lens mount from coming loose, then raise the lens fixing lever, and remove the lens mount cap.

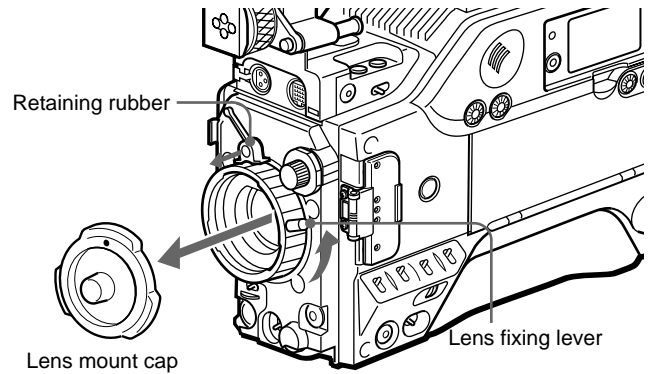

- 2 With the lens fixing lever turned fully counterclockwise, push in the lens, aligning the projection on the lens with the cutout on the camcorder.

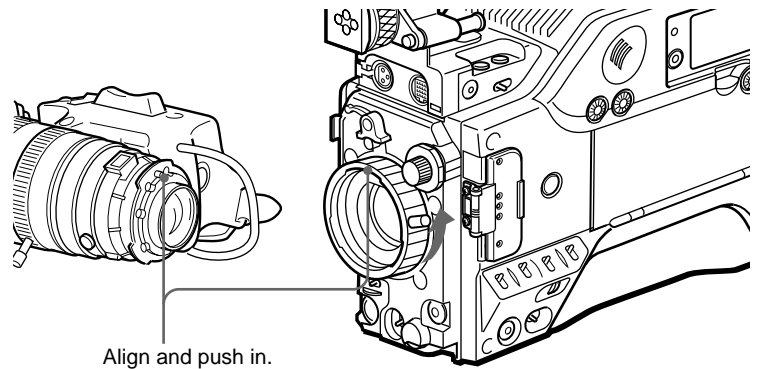

- 3 Supporting the lens, turn the lens fixing lever fully clockwise. Replace the retaining rubber on the lens mount.

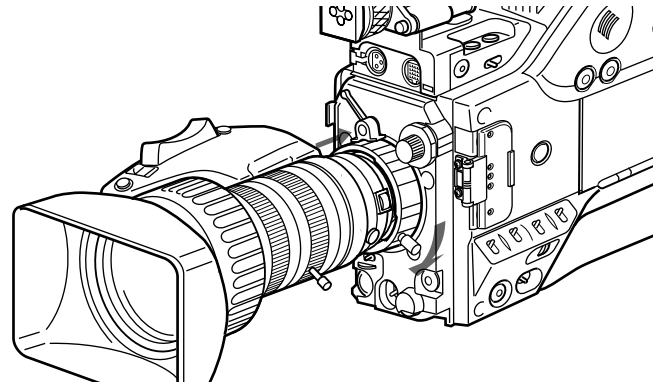

Fitting optional filters

Loosen the lens hood fixing knob to remove the lens hood, then attach the filter.

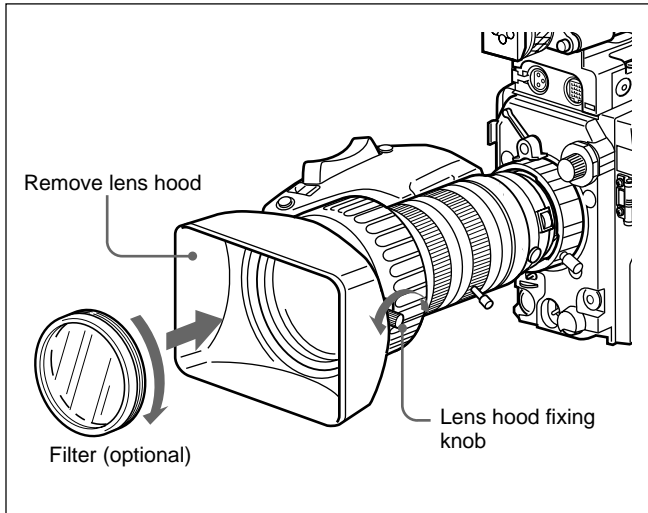

Using Accessories

Using the Viewfinder

Removing the viewfinder

- 1 Pull the viewfinder plug out of the VF connector on the front.

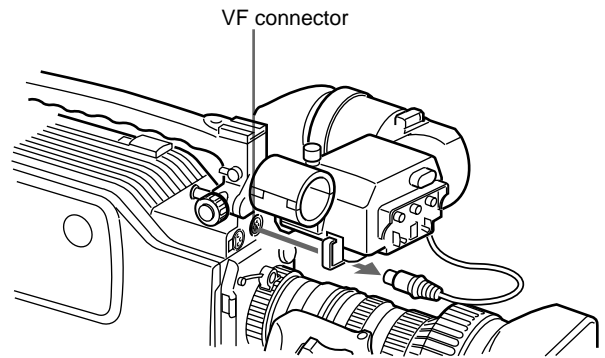

- 2 Loosen the viewfinder left-to-right position fixing ring, then pulling up the retaining catch, slide the viewfinder out.

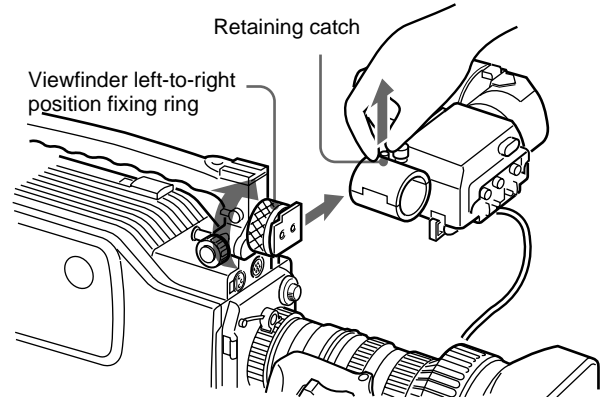

To fit the viewfinder

Reverse the removal procedure. (You need not hold the retaining catch up.)

Left eye adaptor

By fitting a left eye adaptor, you can use the camcorder with your left eye to the viewfinder.

Note

You cannot stow the camcorder with a left eye adaptor attached in the carrying case.

For details, consult your Sony dealer.

Adjusting the viewfinder position

To adjust the viewfinder left-to-right position, loosen the viewfinder left-to-right fixing ring, and to adjust the front-to-back position loosen the viewfinder front-to-back position locking knob.

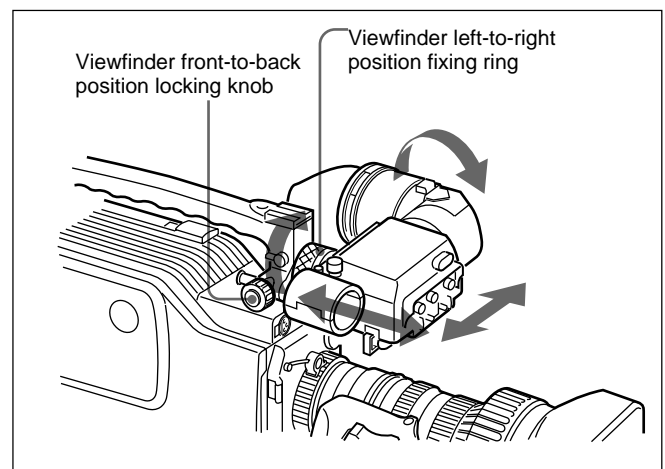

Fitting the 4-inch/5-inch Electronic Viewfinder

You can fit the optional DXF-51 (5-inch)/DXF-41 (4-inch) Electronic Viewfinder. To fit, the following parts are required.

Required parts to fit

Name	Part No.
Accessory Shoe Kit	A-8274-968-B
Adaptor cable (8-pin ↔ 20-pin) (DXF-41 only)	1-783-665-11

For details, consult your Sony dealer.

How to fit

Remove the cover of the grip and attach the shoe and stopper screw (accessory shoe kit).

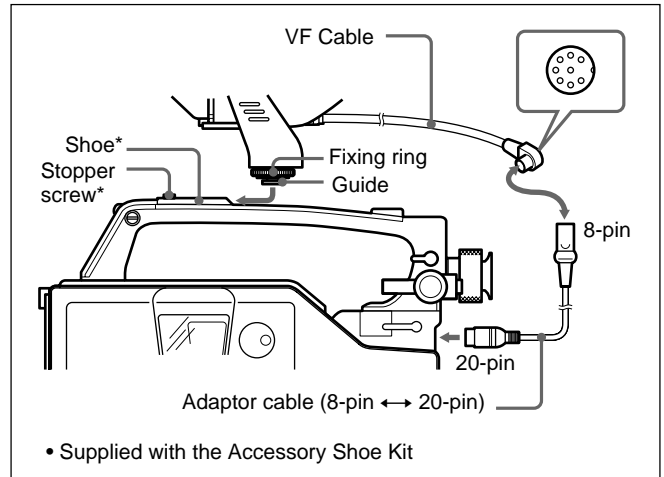

Fitting to a Tripod

First fit the VCT-U14 Tripod Adaptor to the tripod, then mount the camcorder on the tripod adaptor.

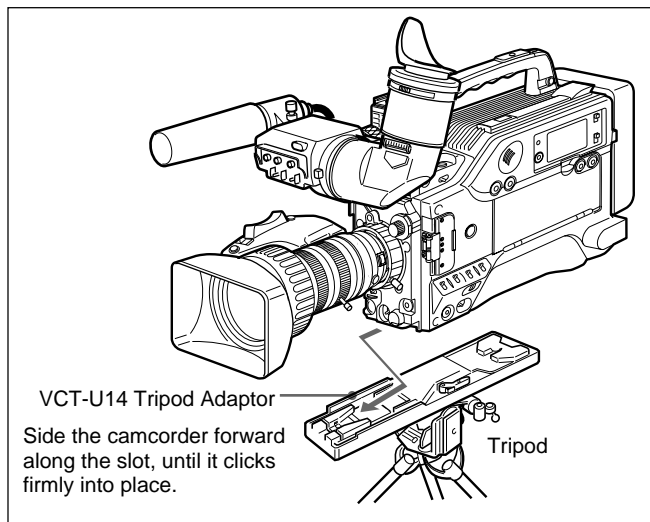

Note

After removing the camcorder, if the tripod adaptor pin has not returned to its original position, hold down the red button and move the lever in the direction of the arrow to return the pin to its original position. It is not possible to mount a camcorder with the pin left out.

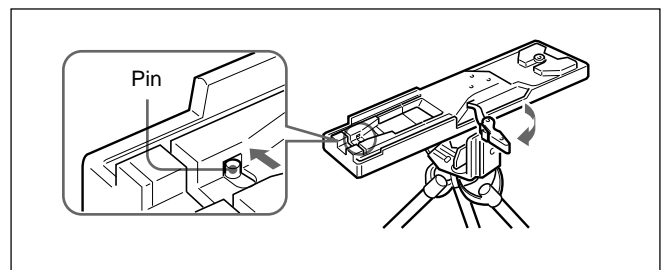

Removal

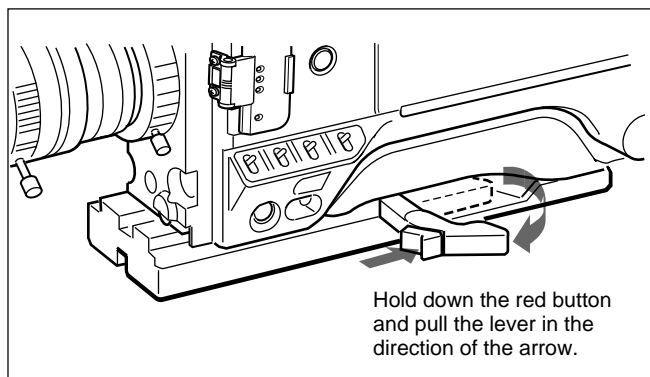

Using Accessories

Using an Optional Microphone

To use a long microphone such as the optional ECM-670/672, fit an optional CAC-12 Microphone Holder to the camcorder, then mount the microphone in this holder.

Fitting the optional CAC-12 Microphone Holder

Remove the two retaining screws (M3 × 8) for the optional microphone holder, then use these screws to

attach the CAC-12 Microphone Holder.

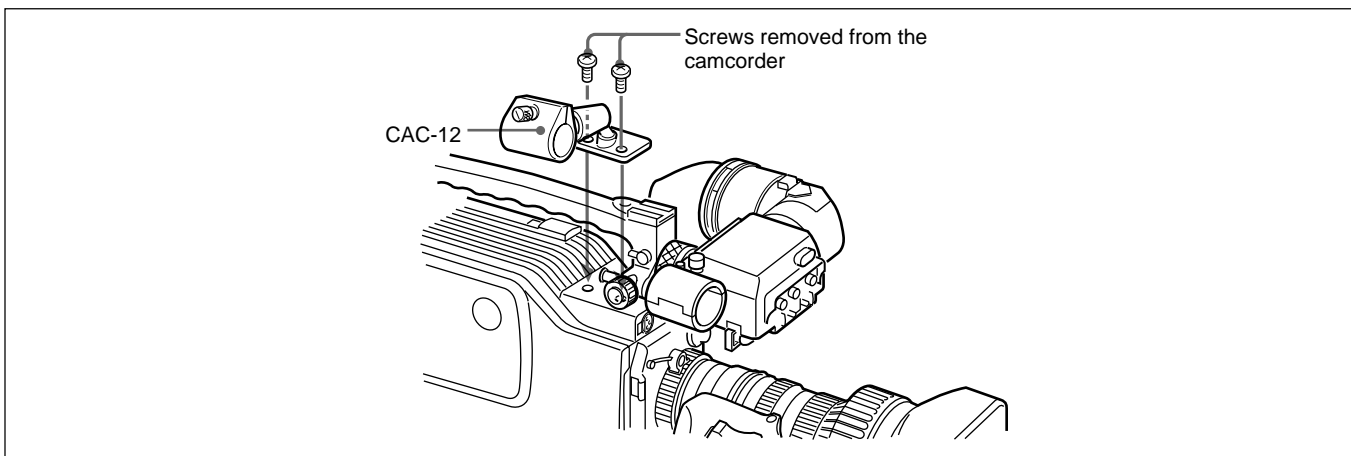

Fitting an optional microphone

Use the following procedure to attach an optional ECM-670 Microphone.

Loosen the screw of the CAC-12 Microphone Holder, then open the holder and replace the microphone adaptor with the one supplied with the ECM-670 Microphone.

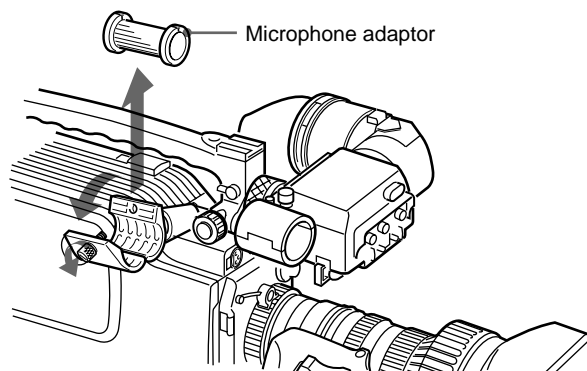

Fitting optional microphones (operable with a 48 V supply) other than the ECM-670

Use the same fitting procedure as for the ECM-670, but note the following differences with respect to the microphone adaptor.

ECM-672: no microphone adaptor required.
Slender microphones (19 mm (3/4 inch) diameter): use the microphone adaptor supplied with the CAC-12.

Using a Video Light

For the DSR-500WSL/500WSPL, you can use the Anton Bauer Ultralight 2 or equivalent. Use a video light powered by 12 V with maximum power consumption of 30 W.

- If you connect the video light to the video light connector on the DSR-500WSL/500WSPL (page 23) and set the LIGHT switch to AUTO (page 13), you can turn the light on and off automatically as you start and stop VCR operation.
- The output of the video light connector on the DSR-500WSL/500WSPL is controlled to 12 V even when the camcorder is supplied with 12 V or more power (through the DC IN connector or battery pack). The brightness or color temperature of the light will not change according to voltage increase.

Notes

- Do not use the video light with power consumption of over 30 W.
- The brightness or color temperature of the light will change when the supplied voltage is under 12 V (through the DC IN connector or the battery pack).

To fit the video light

Fit the video light to the camcorder grip and connect the video light cable to the video light connector.

When using a video light with a long cable

You can pass a part of the cable through the camcorder grip.

- 1 Remove the cover of the camcorder grip and break off projection A (see the figure).

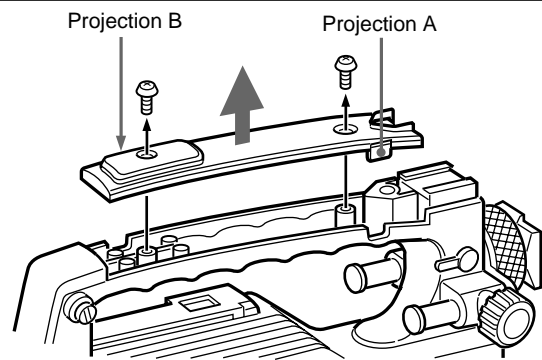

- 2 Pass the cable through the grip as shown in the figure and replace the cover.

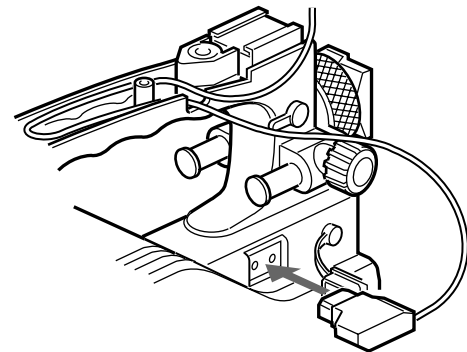

When using equipment other than the camcorder for power supply

Break off projections A and B on the camcorder. (See step 1 of the previous section “When using a video light with a long cable”.) Insert the cable into the grip from the front hole and take out from the rear hole as shown in the figure.

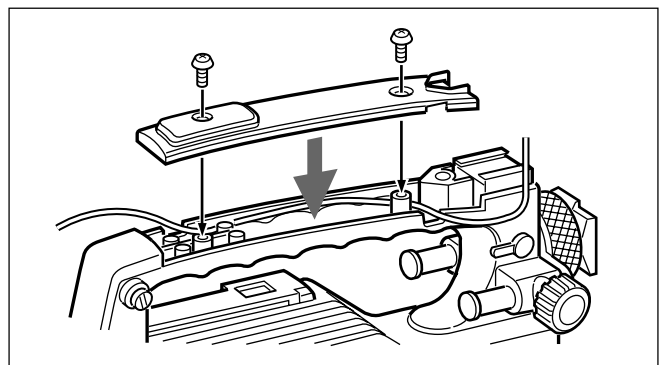

Fitting the Shoulder Strap

This section describes the procedure for fitting the supplied shoulder strap to the camcorder.

- 1 Fit one of the clips to a shoulder strap fitting.

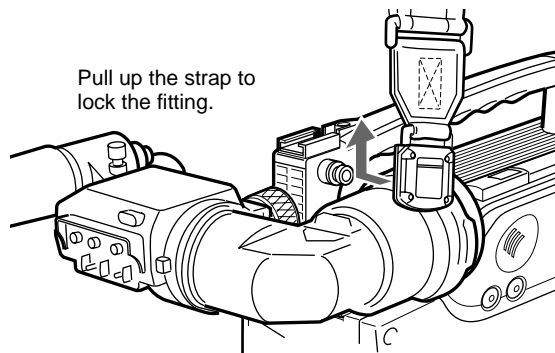

- 2 Fit the other clip to the shoulder strap fitting on the other side of the grip in the same way.

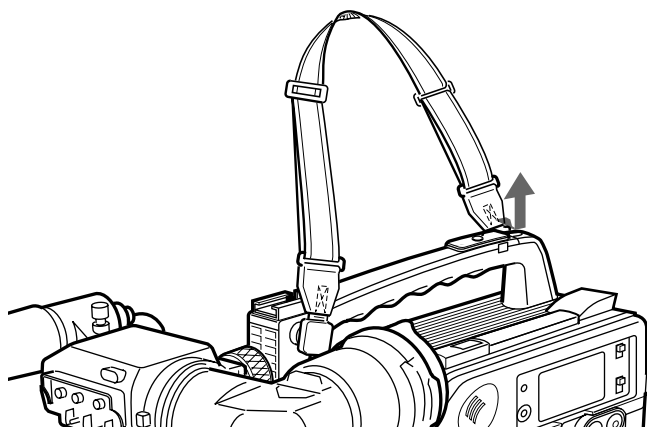

Removing the shoulder strap

Open the cover of the clip and move the clip downwards to release it from the fitting.

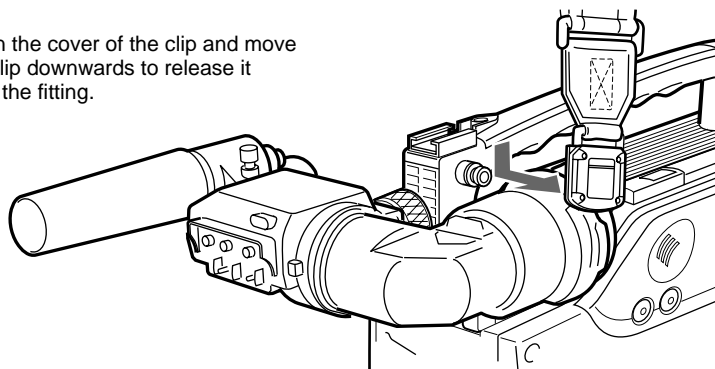

Connecting to Audio System

The DSR-500WSL/500WSPL is able to record sound not only from the microphone attached but also from a wireless microphone or an external audio system.

Using a wireless microphone system

You can use the wireless microphone system including a WRT-810A/830A UHF Wireless Microphone and a WRR-810A/855A/860A UHF synthesized tuner to record sound.

For details on using the wireless microphone system, see the operating instructions for the microphone and tuner.

To connect a WRR-855A

- 1 Open the cover of the WRR connector.

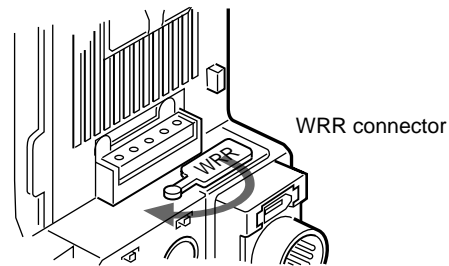

- 2 Insert the WRR-855A into the CA-WR855.

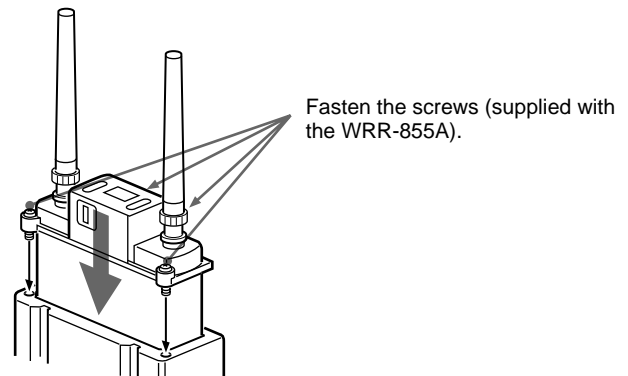

- 3 Fit the attachment plate on the rear side of the CA-WR855 to the V-groove on the battery attachment interface, and then slide the CA-WR855 down until it connects to the WRR connector.

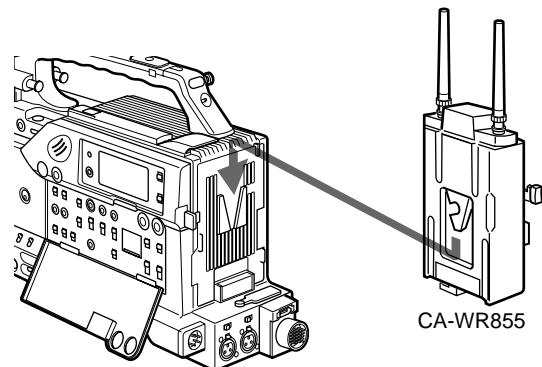

- 4 Set one of the AUDIO IN (CH-1/CH-2) switches to WRR.

Using Accessories

To connect a WRR-810A/860A

Attach the WRR tuner fitting (not supplied) (Part No. A-8278-057-A) to the rear of the camcorder as shown in the following figure.

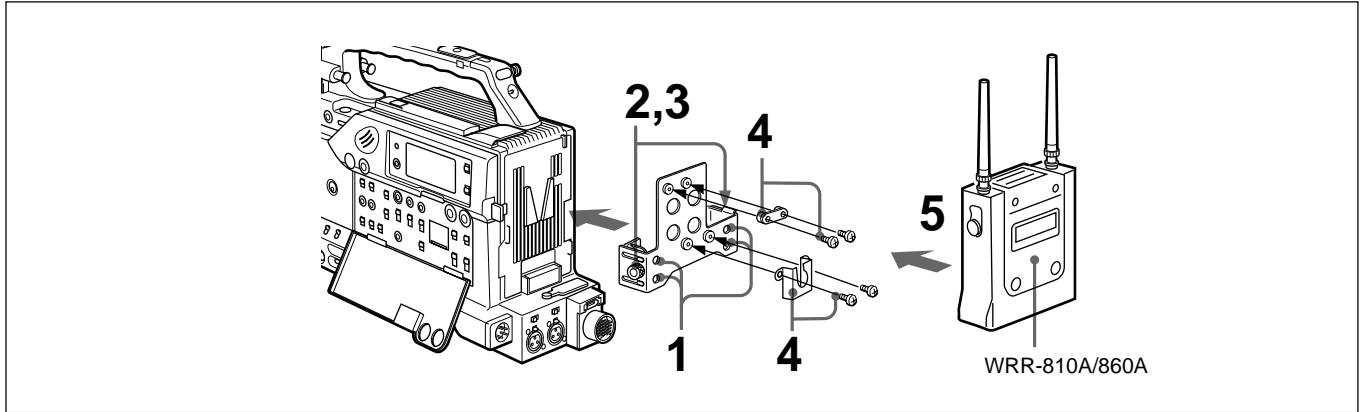

- 1** Pass a screwdriver through the holes and tighten the screws.
- 2** Loosen the adjustment screws.
- 3** Adjust the metal fitting position for a battery pack to be attached, and tighten the adjustment screws to fix its position.

- 4** Attach the holder kit (two fittings and four screws, supplied with the tuner) to the WRR tuner fitting (one for the upper position and the other for the lower position).

- 5** Mount the tuner on the WRR tuner fitting.

For details about the WRR tuner fitting (Part No. A-8278-057-A), contact your Sony dealer.

Using an external audio system

Connect an audio mixer or other external audio system component to the AUDIO IN CH-1/CH-2 connector as shown below.

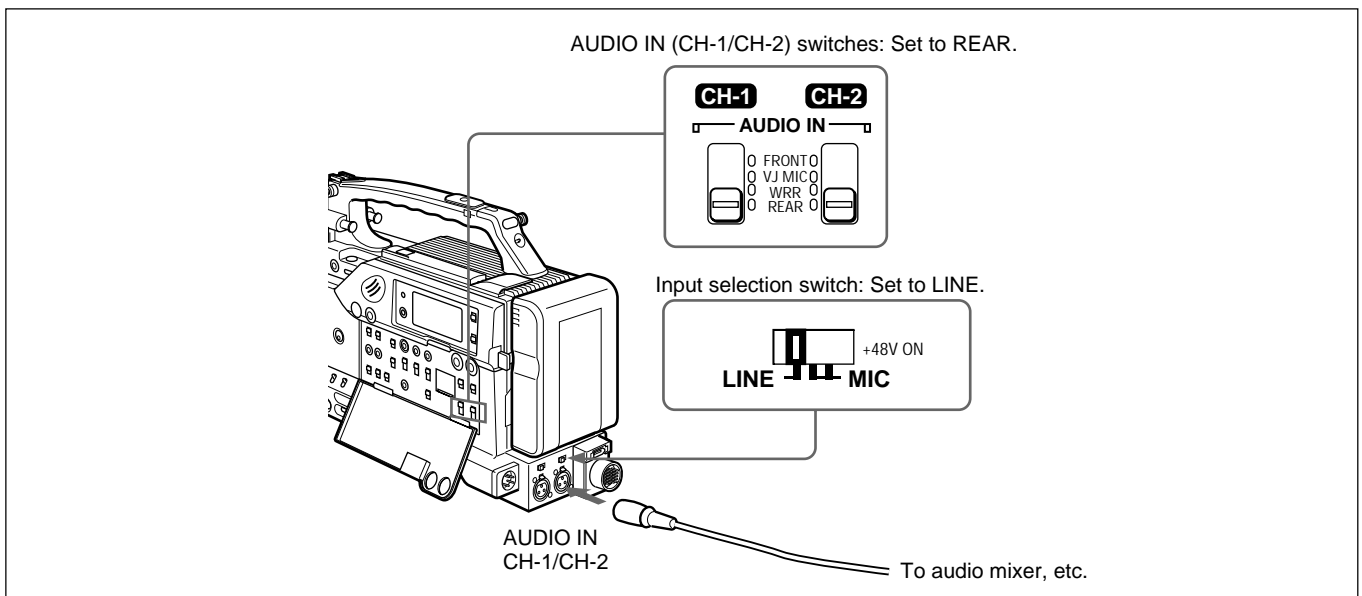

Using the Optional RM-VJ1 Remote Control Unit (Equipped With Microphone And Monitor)

You can control the camcorder while watching the image on the LCD screen of the Remote Control Unit if you connect the RM-VJ1 Remote Control Unit to the camcorder.

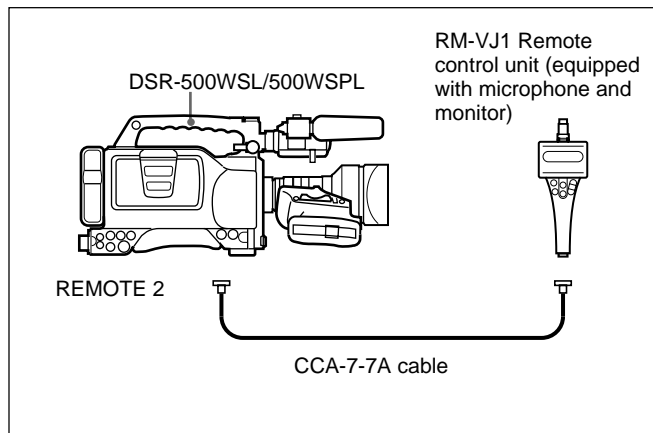

Note

Be sure to use the CCA-7-7A Cable only when connecting the RM-VJ1.

When using lens designed for the power zoom and focus

Use the following lens when controlling the zoom and focus from the RM-VJ1:

- Fujinon: A19X8.7 BRD-S28
- A19X8.7 BERD-S28 (with the extender)
- A19X8.7 BRRD-S28 (with the ratio converter)
- Canon: YJ18X9B KAS-SS12
- YJ18X9B IAS-SS12 (with the extender)

For details on these lens or other lens designated for the power zoom and focus, consult Fujinon or Canon dealer.

When using conventional lens

When using conventional lens, such as VCL-918BY, you can control the zoom if you use the optional lens cable (Sony product number: 1-790-779-11). For details on the cable, consult your Sony dealer.

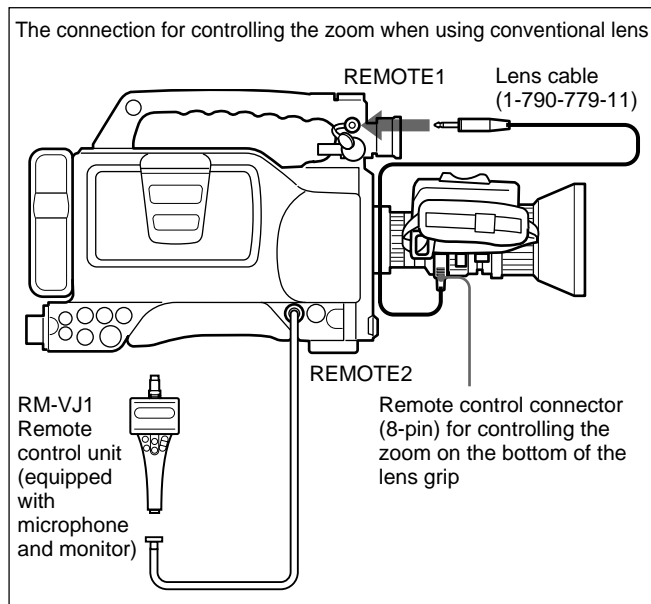

Using the RM-LG1 Remote Control Unit

You can control the camcorder using the supplied RM-LG1 Remote Control Unit.

Location and Function of Parts

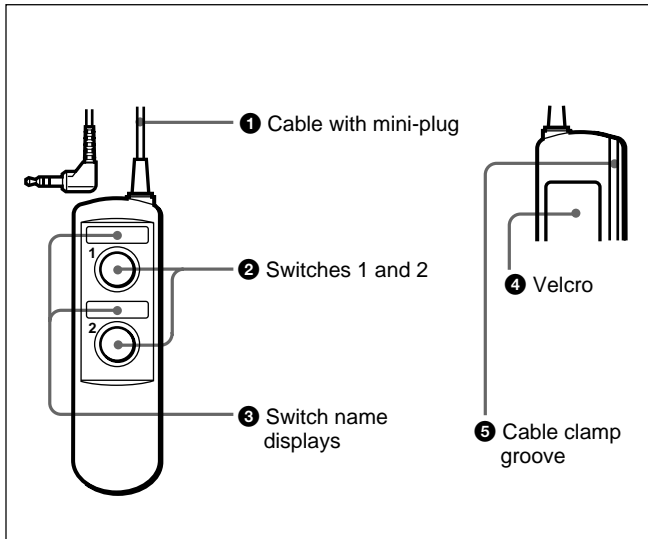

1 Cable with mini-plug

Connect to the REMOTE connector 1 (5 on page 23) on the DSR-500WSL/500WSPL.

2 Switches 1 and 2

You can assign functions to these switches using the advanced menu page 3 (see page 88) of the DSR-500WSL/500WSPL.

Each can be used as the following types of switch: VTR switch, MARK switch, CUE switch, or NG switch.

At the shipping of the DSR-500WSL/500WSPL, switch 1 is set as the VTR switch and switch 2 is set as the MARK switch.

For information about the advanced menu and function of each switch, see "Location and Function of Parts" on page 12 and "Viewfinder Advanced Menu" on page 86.

3 Switch name displays

Stickers (supplied with RM-LG1) can be attached here to indicate which functions are assigned to the switches 1 and 2 2.

4 Velcro

When using the unit on the panning rod of the tripod, this is used to attach the unit to the panning rod mounting bracket (supplied with RM-LG1).

5 Cable clamp groove

When the cable 1 is passed underneath the unit, the cable can be placed in this groove.

Attaching the RM-LG1

Use the binding ties and panning rod mounting bracket to attach the unit to a panning rod.

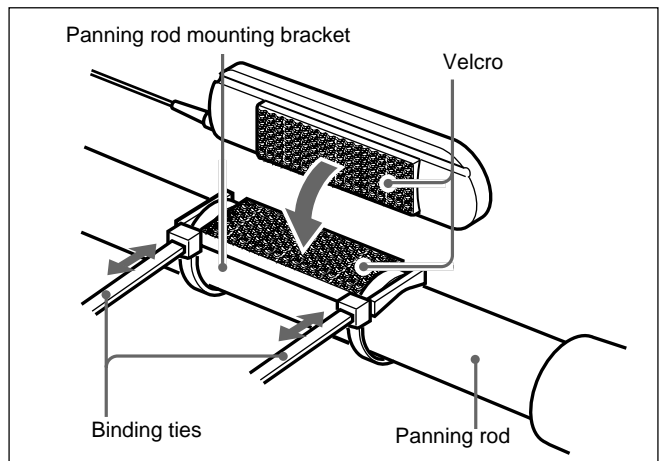

Removing the RM-LG1

Lift up the tab to loosen the binding ties.

Using the Optional LC-DS500 Carrying Case

For details on using the carrying case, refer to the instruction manual supplied with the carrying case.
For detail on the time that the carrying case will appear on the market, consult your Sony dealer.

Using the Optional LC-DS300SFT Soft Carrying Case

For details on using the soft carrying case, refer to the instruction manual supplied with the soft carrying case.

Connecting a Number of Camcorders

When using two or more synchronized camcorders, connect an external sync signal to the GEN LOCK IN connector, supplying a VBS or BS signal. The camcorder will then operate synchronized to this signal.

You can adjust the synchronization using the basic menu. (See page 81.)

Note

When you fit the optional DSBK-501/501P, set the VIDEO IN to CAM using the basic menu page 4. (See page 81.)

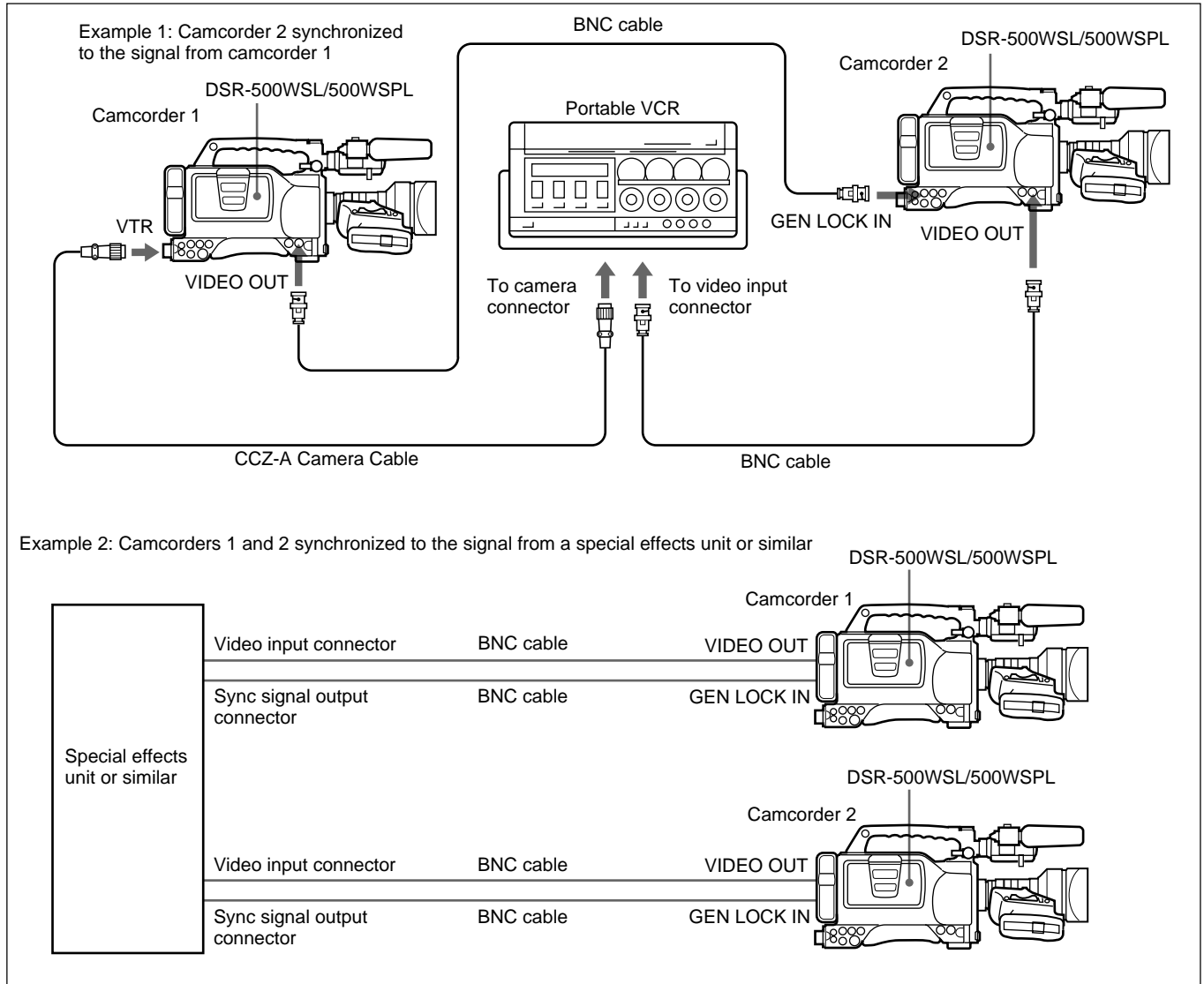

Connecting the DSR-70/70P Digital Videocassette Recorder (Optional DSBK-140 Is Required)

You can do cut editing and digital dubbing when connecting the DSR-70/70P with fitting the optional DSBK-140, using an i.LINK cable (DV connecting cable).

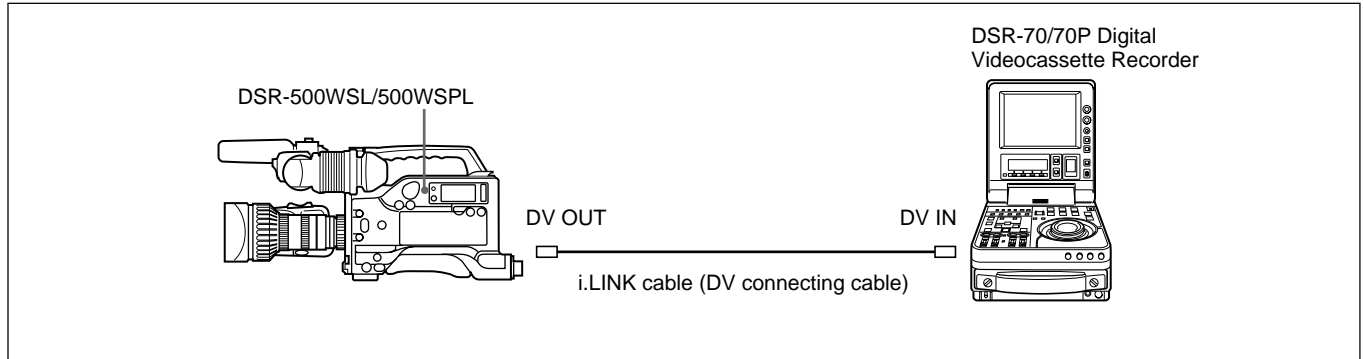

Notes

- The camcorder does not support the noiseless function of the various speed playback.
- The slow playback will be automatically released to protect the tape if the slow playback lasts for about one minute.
- When dubbing tapes using the DSR-70/70P, a continuous recorded section of approximately five seconds is required before the recording start point. It is recommended to record beforehand color bars or a similar signal at the start point of the source tape to be dubbed on this unit.

Connecting an External VCR

You can use a following external VCR connected to the VTR connector (26-pin) or the DV OUT connector for recording.

Connector	VCR	Connecting cable
VTR connector	BVW-50/50P/35/35P (portable)	CCZ-A Camera cable (max. length 10 m (33 ft.))
VTR connector	VO-8800/6800 (U-matic)	CCZQ-A Camera cable (max. length 10 m (33 ft.))
DV OUT connector	Digital Videocassette Recorder DSR-20/20P/70/70P/2000/2000P, etc.	i.LINK cable (DV connecting cable) (max. length 4.5 m (14 ft.))

Notes

- There is no power supply connection between the camcorder and VCR. Provide separate power supplies.
- The VTR connector always outputs the signals from the camera (impossible to output the playback video of the internal VCR), and disallows the CCU connection.
- When no VCR is connected to the VTR connector (26-pin), it does not supply signals.

Power Supply

The following power supplies can be used with the camcorder.

- BP-L40/L40A/L60/L60A/L90/L90A lithium-ion battery pack
- NP-1B Ni-Cd Battery Pack (The DC-L1 Battery Adaptor is required.)
- BP-90A Ni-Cd Battery Pack (The DC-L90 Battery Adaptor is required.)

- AC power (The AC-550/550CE, AC-DN1/DN2A or CMA-8A/8ACE AC Adaptor is required.)

Alternatively, you can make combined use of internal and external batteries, by mounting one of the above batteries as an internal battery and connecting an external battery that can be a BP-90A contained in a DC-210 Battery Adaptor and connected to the DC IN connector of the camcorder.

Using a BP-L40/L40A/L60/L60A/L90/L90A Battery Pack

With a battery pack, the camcorder will operate continuously for the time shown below.

BP-L40/L40A: Approx. 70 minutes

BP-L60A: Approx. 140 minutes

BP-L90A: Approx. 230 minutes

Before use, charge the battery pack with a BC-L50/L100/L100CE Battery Charger.

Notes on using the battery pack

- A warm battery pack may not be able to be fully recharged.
- Even when fully charged, battery packs gradually lose their charge naturally. Use the battery packs as soon as possible after recharging.
- To prolong the life of battery packs, store them in a cool place (about 20°C (68°F)), and charge in a place with an ambient temperature between 10°C and 30°C (50°F to 86°F).
- Before long-term storage, discharge the battery fully. This extends the battery's life.
- It is recommended that the BP-L40/L40A be used at 30 W or less. The specified capacity may not be obtained if it is connected to the camcorder with accessories which is operated at 30 W or higher, especially when the ambient temperature is low.

- At low temperatures, the usable time of battery packs decreases. When the ambient temperature is 0°C (32°F), usable time decreases by about 10%. (However, the usable time is affected by the power consumption of the connected camcorder and the usage status of the battery packs.) The usable time of battery packs increases if they are warmed to the room temperature (about 20°C (68°F)) before use at low temperatures.
- If you use the BP-L40/L40A at temperatures of 0°C (32°F) or below, when power consumption of the camcorder and accessories is 40 W or higher (due to using a video light, for example), power may break after a short time (a few minutes). To increase the usable time, store the BP-L40/L40A in a warm place and power on the connected camcorder before the BP-L40/L40A cools down.
- Compared to the BP-L40/L40A, the BP-L60/L60A/L90/L90A offer better performance at low temperatures. The BP-L60/L60A/L90/L90A are recommended for use at low temperatures.
- Carrying a spare battery pack is recommended.

The BP-L40/L40A/L60/L60A/L90/L90A is free from memory effect. There is no need to discharge it fully before recharging.

Attaching the battery pack

- 1 Press the battery pack against the rear of the camcorder, aligning the side line of the battery pack with the line on the camcorder.

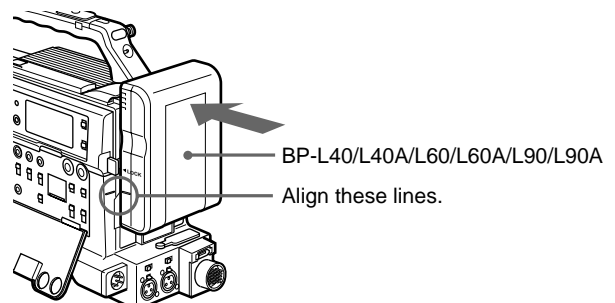

- 2** Slide the battery pack down until its “LOCK” arrow points at the matching line on the camcorder.

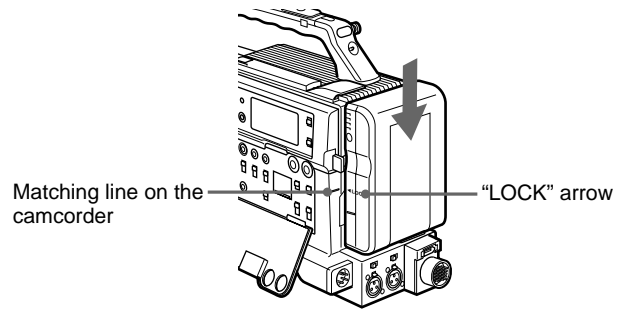

Detaching the battery pack

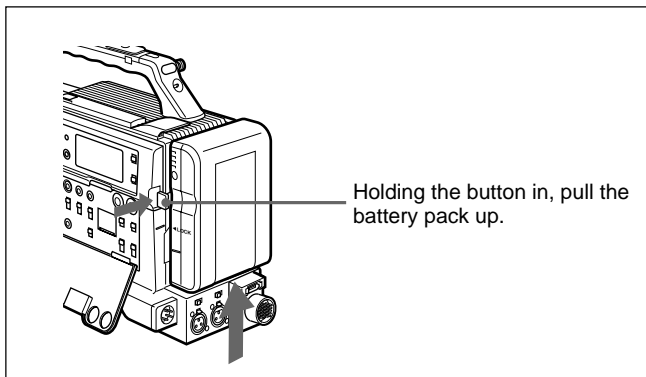

Continuous operation when operating with only an internal battery pack

First, connect a fully charged external battery to the DC IN connector, then change the internal battery.

Notes

- Whenever an internal battery pack is loaded and an external battery is connected to the DC IN connector, the external battery is always used as the power source.
- There may be some noise on the video or audio signal at the instant the power sources are switched.

Avoiding breaks in operation due to dead batteries

If you use both an internal battery pack and an external battery connected to the DC IN connector at the same time, you can avoid breaks in operation due to the dead batteries.

When the external battery begins to fail and an internal battery pack is also used

Remove the DC output cable of the external battery from the DC IN connector. The power source will switch to the internal battery pack.

When the external battery begins to fail and an internal battery pack is not used

First load the camcorder with a fully charged internal battery pack, then remove the DC output cable of the external battery from the DC IN connector. The power source will switch to the internal battery pack. To use an external battery again, connect a fully charged external battery to the DC IN connector before unloading the internal battery pack. The power source will switch to the external battery.

Power Supply

Using an AC Adaptor

Using a CMA-8A/8ACE AC Adaptor

Connect the camcorder to the AC power supply as shown in the following figure, and turn the POWER switch of the CMA-8A/8ACE to ON.

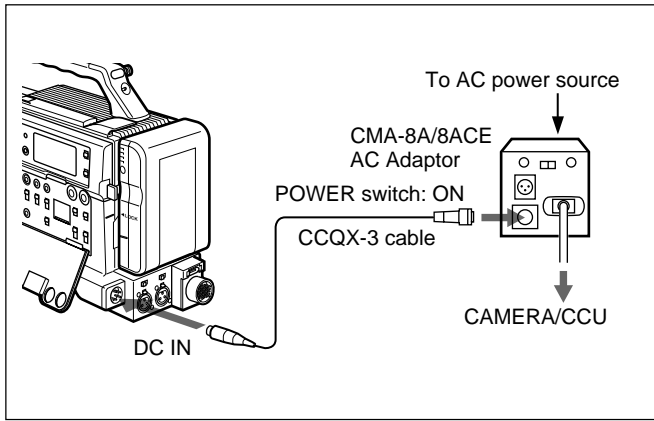

Using an AC-DN1/DN2A AC Adaptor

Mount the AC-DN1/DN2A on the camcorder in the same way as a battery, then connect to the AC power source.

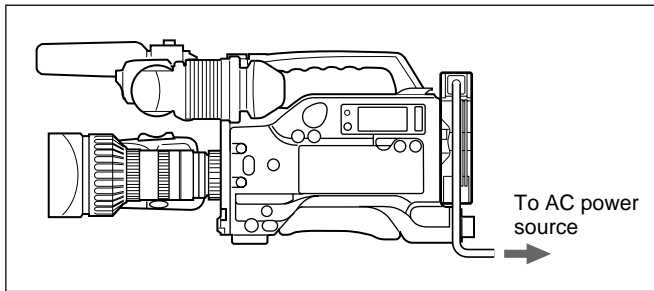

Note

When power consumption of the camcorder and accessories is 38 W or higher, use the AC-DN2A AC adaptor (lower than 150 W).

Using the Anton Bauer Intelligent Battery System

You can equip the camcorder with a special battery mount which the Anton Bauer Corporation has developed for its Intelligent Battery System and Ultralight System.

When the camcorder is used with an Anton Bauer Digital Magnum series battery, the remaining battery capacity is shown numerically in the viewfinder display.

Contact your Sony dealer for more information.

Basic Procedure for Shooting

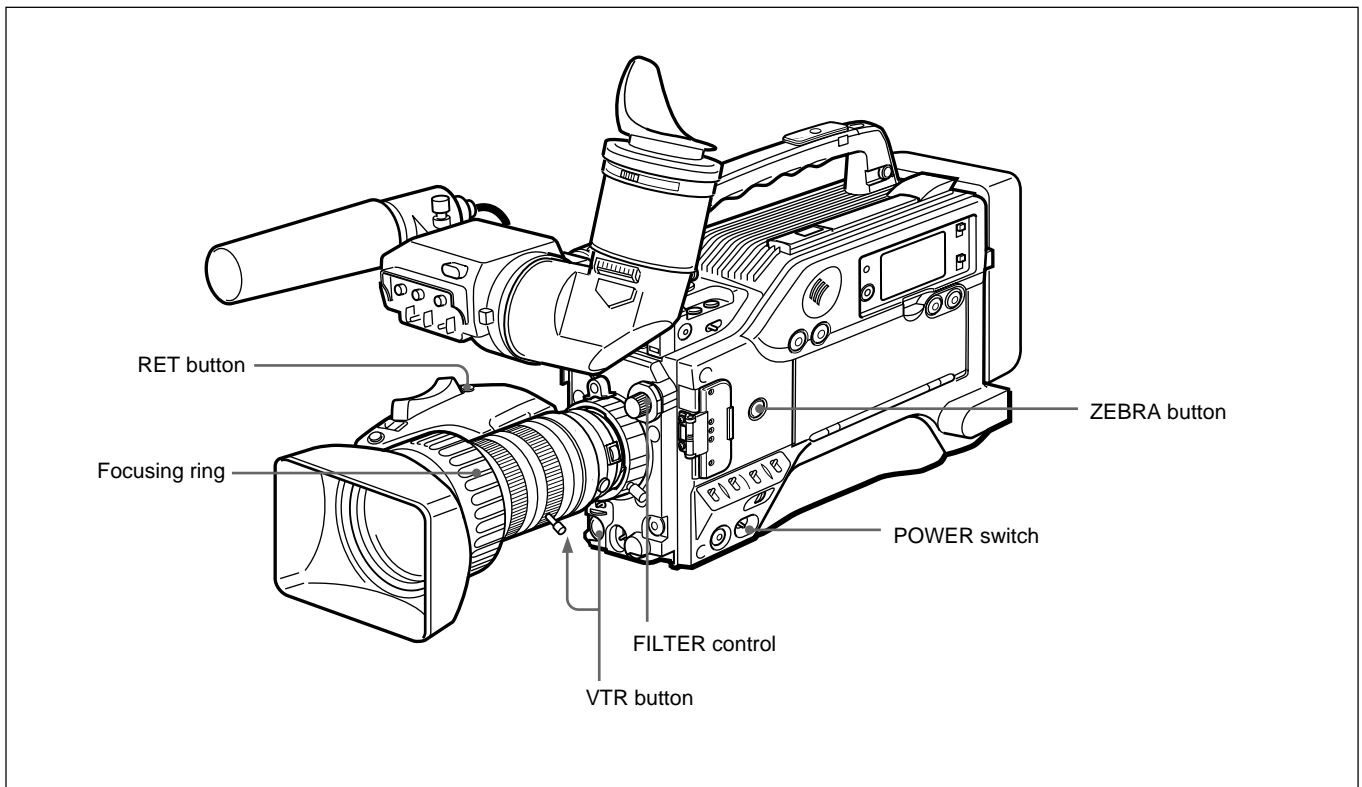

- 1 Power the camcorder.
- 2 Set the FILTER control appropriately for the lighting conditions.

Filter setting	Lighting conditions
1 (3200K)	Studio halogen lighting (incandescent), sunrise and sunset.
2 (5600K + 1/8 ND)	Sunlight. This setting includes a 1/8 neutral density filter (reducing the exposure by the equivalent of three stops). Use it to prevent hunting ¹⁾ or to reduce the depth of field ²⁾ .
3 (5600K)	Cloudy or rainy outdoor shooting, and fluorescent lighting.
4 (5600K + 1/64ND)	Sunlight. This setting includes a 1/64 neutral density filter (reducing the exposure by the equivalent of six stops). Use it to prevent hunting ¹⁾ or to reduce the depth of field ²⁾ .

Note

Noise may appear in the EZ mode if the FILTER control is set to 2 or 4, and iris is set to fully open. In such case: when the FILTER control is set to 4, set it to 2; when set to 2, set it to 3.

- 3 Check the switch settings on the camcorder. (See pages 12 to 26).

If there is not sufficient time to check the camcorder settings, you can use “easy mode” by setting the EZ MODE button ON. The camcorder is automatically adjusted to standard settings, and the iris and the white balance are adjusted automatically. (See page 91.)

- 4 Check the settings in the basic menu (page 80) and advanced menu. (page 86.)
- 5 Check the lens settings (pages 32 and 33) and flange focal length adjustment. (page 119.)
- 6 Adjust the eyepiece focus, and the contrast and brightness of the viewfinder image. (page 118.)

1) **Hunting:** This occurs if the automatic iris function is not able to reach a stable state, and as a result the image brightness keeps changing, alternately lighter and darker.

2) **Depth of field:** This is the range over which the subject is sharply in focus.

Basic Procedure for Shooting

- 7 Check the sound system settings.
 - Microphone connections
 - Settings on the VCR section
- 8 If required, switch on the center marker and/or safety zone (basic menu page 6 and advanced menu page 4) and zebra pattern (ZEBRA button) in the viewfinder image.
- 9 Adjust the white balance (*page 112*) and black balance (*page 115*).

- 10 Turn the focusing ring so that the subject is sharply in focus.

It may be convenient to use the EZ FOCUS button for the “easy focus” function. (*See page 13.*)

- 11 Set up the VCR section according to your shooting objectives, then start recording with the VTR button.

- During recording, the REC/TALLY indicator(s) in the viewfinder light(s), and “REC” appears on the viewfinder screen.
- Depending on the setting of the REC TIME switch (*see page 21*), you can display the total recording time or the length of the current cut on the viewfinder screen.
- You can use the AUDIO LEVEL knob on the right side to manually adjust the channel 1 audio level. To do this, you must first set up the VCR section to enable manual adjustment of the audio recording level. (*See page 20.*)

- 12 To pause recording, press the VTR button again.

Using DynaLatitude Function

This function enables detailed adjustment of contrast control in each pixel in accordance with a histogram of luminance signal levels.

If use this function, the camcorder automatically adjusts contrast control by detecting luminance levels of each subject.

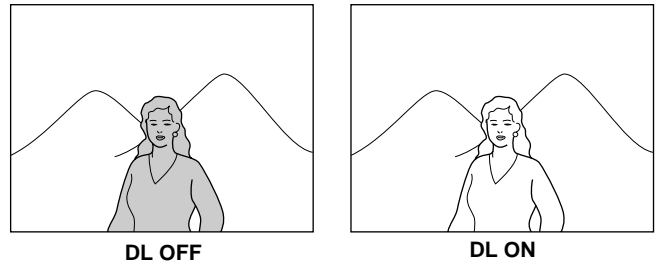

However, if a subject moves in shooting, the brightness of the subject may be changed; noise on the black portion may increase depending on subjects. For turning on/off the function, see page 88, and for the effect level, see page 81.

Cassettes for the DSR-500WSL/500WSPL

The DSR-500WSL/500WSPL can use standard-size and mini-size DVCAM and DV series metal tape cassettes. (To ensure high-quality playback, editing, and storage of recorded contents, we recommend using highly reliable DVCAM cassettes).

The following table lists the cassettes that can be used in the DSR-500WSL/500WSPL.

Model name	Size
PDV-64ME/64MEM/94ME/124ME/124MEM/184ME/184MEM	Standard size
PDVM-12ME/22ME/32ME/32MEM/40ME/40MEM	Mini size

The numbers in the model names show maximum recording/playback time (minutes) for each model. For example, the maximum recording/playback time of the PDV-184ME is 184 minutes.

Notes

- If you insert an incorrect type of cassette, it will be automatically ejected.
- When using a DV cassette, the maximum recording time is reduced to two-thirds of the time indicated on the cassette. For example, up to 40 minutes of recording can be done on a 60-minute DV cassette.

DVCAM cassettes

The following figure illustrates the DVCAM cassette's appearance.

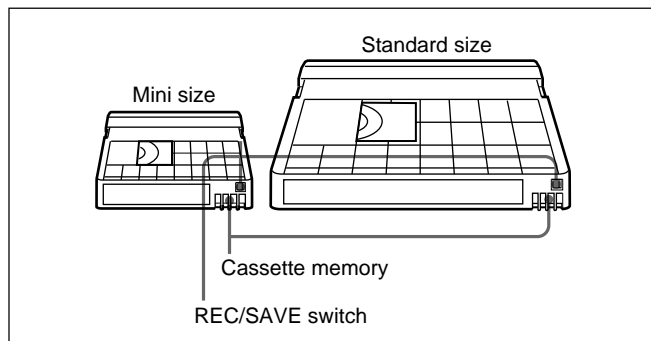

For ClipLink shooting, a DVCAM cassette including "cassette memory" is necessary. In the cassette memory, data required for editing the recorded video (ClipLink log data) is stored. The DSR-500WSL/500WSPL can record or play back the cassettes with cassette memory of 16 Kbits or less.

For details of ClipLink log data, see "ClipLink Shooting" (page 68).

Notes on using cassettes

- Before storing the cassette, rewind the tape to the beginning and be sure to put the cassette in its storage case, preferably on end instead of flat on its side. The storage case of a DVCAM cassette is specially designed to ensure a long-period storage of the tape. Storing a cassette in any other condition (not rewound, out of its case, etc.) may cause the video and audio contents to become damaged over time.
- If the cassette memory connector (contact point) becomes dirty, connection problems may occur and cause a loss of functions. Remove away any dust or dirt from this area before using the cassette.
- If the cassette is dropped on the floor or otherwise receives a hard impact, the tape may become slackened and may not record and or play back correctly. For instructions on removing tape slack, see next page.
- Follow the instructions on page 53 to insert a cassette, or the camcorder may be damaged.

Preventing accidental erasure

Set the REC/SAVE switch to SAVE to prevent accidental erasure of recorded contents.

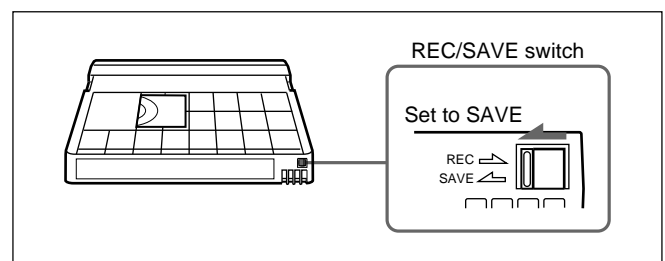

If you insert a cassette into the camcorder when this switch is set to SAVE, the camcorder will not record when you press the VTR button.

To enable recording

Set the REC/SAVE switch back to REC.

Recording

Checking the tape for slack

Turn the reel gently in the direction shown by the arrow. If the reel does not move, there is no slack. Insert the cassette into the cassette holder, close the cassette holder, and after about 10 seconds take it out.

See page 53 on how to insert a cassette.

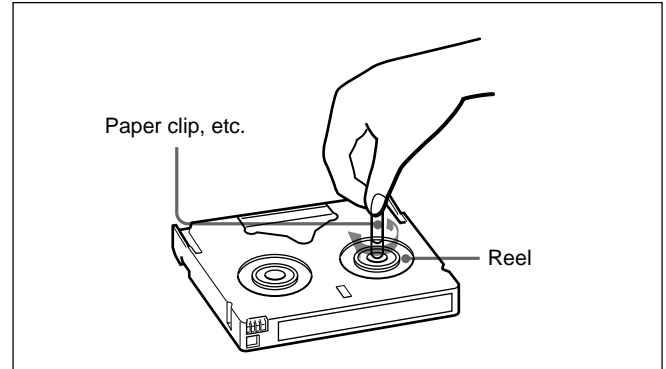

Recording on the Internal VCR

This section describes basic recording operations using the internal VCR.

Notes

- When you will not perform ClipLink shooting, set the ClipLink function to OFF in the VCR menu. (See page 109 for menu setting and see page 68 for details of ClipLink shooting.)
- Before shooting, mount or connect any required equipment or accessories and check the power supply. (See Chapter 2 “Fitting and Connections”.) Also, it is desirable to make sure for problems in camcorder’s internal operations using the auto-check function. (See “Menu 210 Using Auto-Check Function” on page 107.)

- When using a tape recorded by the DSR-500WSL/500WSPL to transfer digital (video/audio/time code) signals at four times normal speed from the DSR-85/85P Digital Videocassette Recorder to the ES-7 EditStation for editing purposes, there must be about at least 40 seconds of recording on the tape before the IN point. To perform editing without problems, it is recommended **that you pre-record at least 40 seconds of color bar signals at the beginning of the tape.**
- When dubbing tapes using the DSR-70/70P, a continuous recorded section of approximately five seconds is required before the recording start point. It is recommended to record beforehand color bars or a similar signal at the start point of the source tape to be dubbed on this unit.

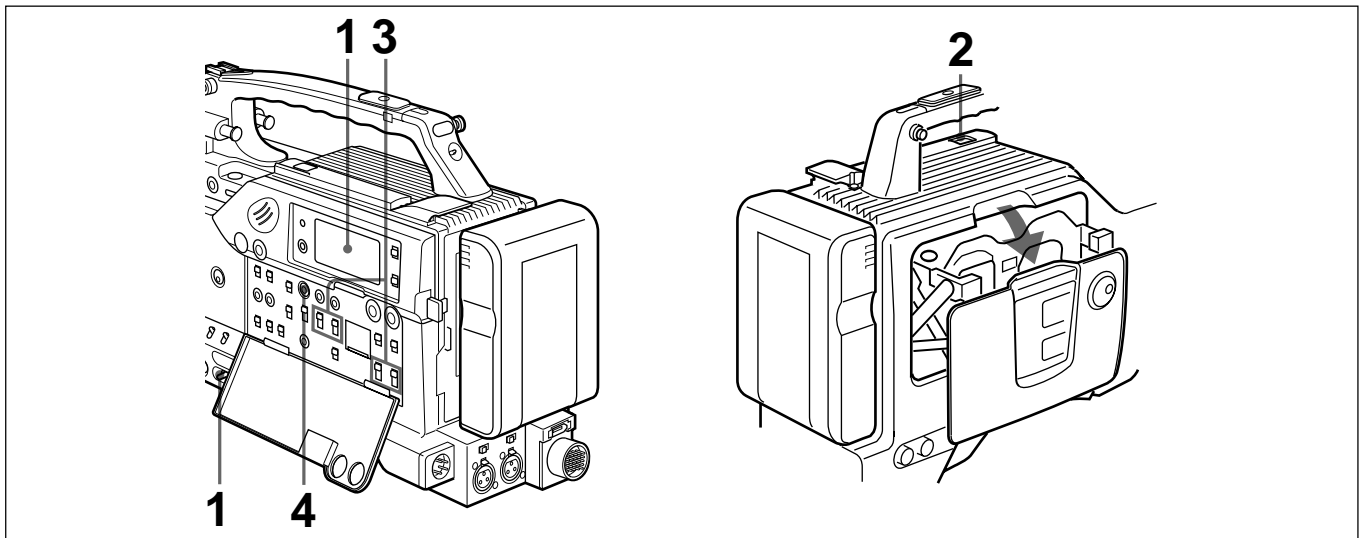

- 1** Set the POWER switch to ON and check the following items in the display window.

Item to check	Indication and steps	See also
How is the battery?	BATT E [■■■■■■■] F: The battery is fully charged. If two or fewer marks ■ appear and the indication is blinking, replace the battery.	“ 8 Display window” (page 16)
Has the lithium battery been inserted and is it charged?	Make sure that the L is not shown in the display window. If it is shown, replace the lithium battery.	“Inserting and Replacing the Lithium Battery” (page 31)
Is there a condensation problem?	Make sure that the “HUMID” indication is not shown in the display window. If it is shown, do not use the equipment until the “HUMID” indication disappears.	“Condensation” (page 128)

- 2** Press the EJECT button to open the cassette holder, and insert the cassette.

Make sure that the cassette’s REC/SAVE switch is set to REC, then check for tape slack before loading the cassette.

For details on handling cassettes, see “Cassettes for the DSR-500WSL/500WSPL” on page 51.

Inserting a standard-size cassette

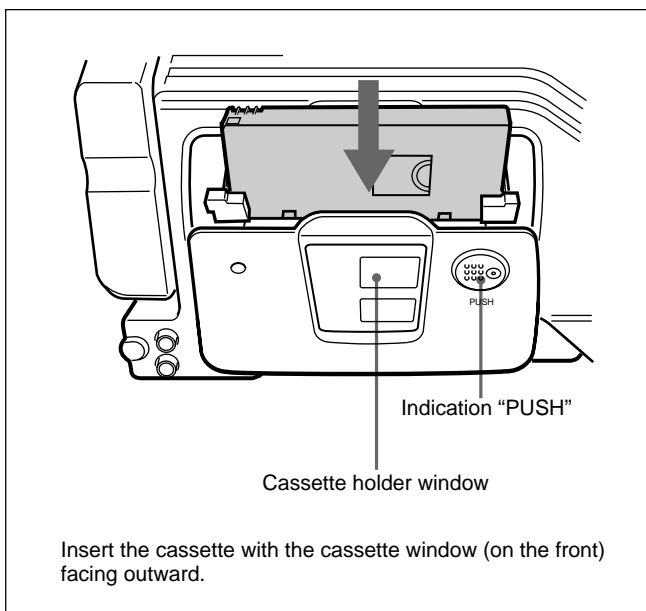

Inserting a mini-size cassette

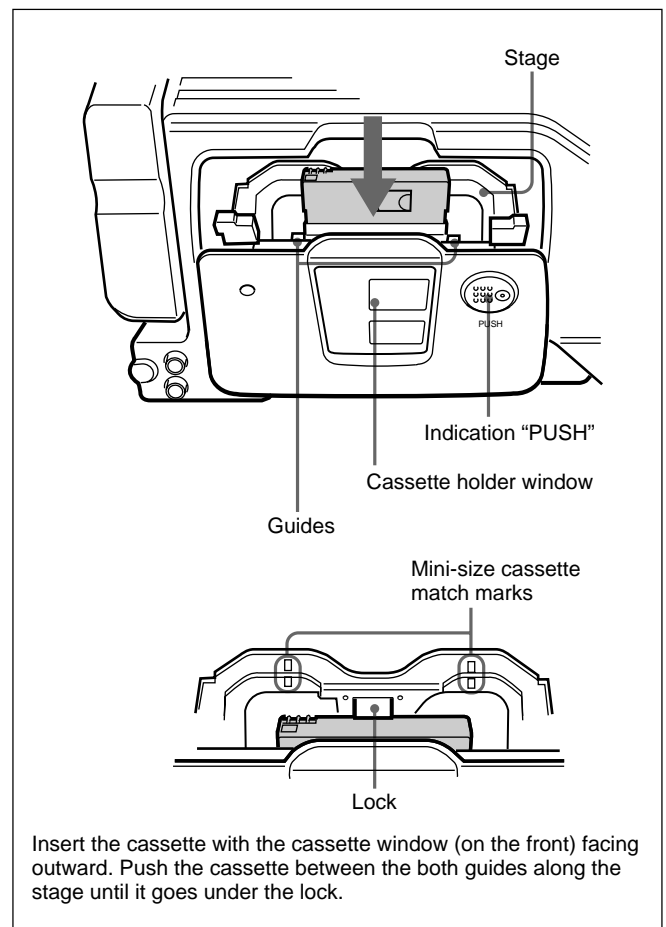

Press on “PUSH” on the cassette holder solidly to close the holder.

(Continued)

Recording

Notes

- Turn the power on and then insert or eject the cassette.
- When inserting a mini-size cassette, confirm the cassette is under the lock (see the figure on the previous page), and then close the cassette holder. If the cassette is not inserted fully under the lock, a stopper will prevent the cassette holder from closing when you press down on it.
- Internal parts of the camcorder may become bent or otherwise damaged if you attempt to close the cassette holder after inserting a mini-size cassette in the wrong direction (such as with the cassette turned backside front so the reel holes face the cassette holder window or with the cassette turned sideways so that a short side enters first).
- If **CL** appears in the display window when the cassette is loaded, it means that data has already been recorded into the cassette memory. If you record under this condition whether the ClipLink function is available or not, the existing cassette memory data will be overwritten. To avoid this, insert a new cassette.

- After inserting the cassette, close the cassette holder solidly by pressing on the “PUSH” indication on the holder. Unless the cassette holder is closed solidly, the tape will not be loaded and the tape operation buttons will not function. If you find the tape operation buttons inoperable, press on the “PUSH” indication again to make sure that the cassette holder is solidly closed.

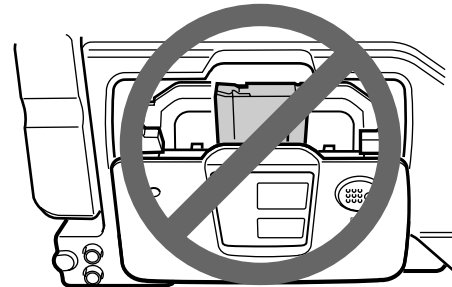

Do not insert cassette sideways.

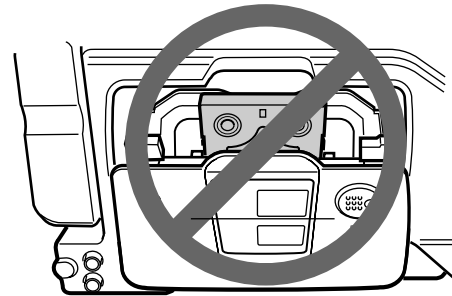

Do not insert cassette backside front.

3 Make the switch settings shown in the figure below.

a) When one of these switches is set to MAN, the recording volume can be manually adjusted. For details, see “Manually adjusting audio recording level” on page 55.

b) For details, see “Setting the Time Code Value” on page 64.

- 4** Display menu 212 and select the audio recording mode (two-channel recording mode or four-channel recording mode).

For menu operation, see “Menu 212 Selecting Audio Recording Mode” (page 109).

Note

One of the following warning indications appears in the display area when you change the audio mode setting during recording pause.

Warning indication	Status
Fs 48k (flashes four times per second)	Attempting to switch from 32-kHz mode (four-channel mode) to 48-kHz mode (two-channel mode).
Fs 32k (flashes four times per second)	Attempting to switch from 48-kHz mode (two-channel mode) to 32-kHz mode (four-channel mode).

The recordings at switching points prevent editing. Avoid changing the audio mode once you have started recording.

- 5** Set up the camcorder to suit your recording objectives, and press the VTR button on the camcorder or lens.

Recording begins when the TALLY indicator stays lit after blinking for a moment.

During recording, the tape transport buttons (EJECT, REW, F FWD, PLAY, and STOP) cannot be used.

Operation	Step
To view image being shot	<ul style="list-style-type: none"> Look into the viewfinder. Connect a video monitor to the MONITOR OUT connector, VIDEO OUT connector, or S VIDEO OUT connector.
To listen to audio track being shot	Connect an earphone to the EARPHONE connector or listen to the audio from the speaker.
To pause recording	Press the VTR button on the camcorder or lens. <i>For instructions on continuing to record after a pause, see “Back Space Editing” (page 58).</i>
To stop recording	Press the VTR button on the camcorder or lens, then press the STOP button. With this state, it is impossible to start back space editing.
To remove the cassette	Check that the power is on, then press the EJECT button to open the cassette holder and remove the cassette. Close the cassette holder.

Manually adjusting audio recording level

- 1** In step 3 above (“Recording on the Internal VCR”), set the AUDIO SELECT (CH-1/CH-2) switches to MAN (see page 54).
- 2** While checking the audio level in the display window, turn the AUDIO LEVEL (CH-1/CH-2) knobs for the channel being used for microphone or wireless microphone system connection (CH-1 or CH-2) so that the maximum audio level is under 0 dB.

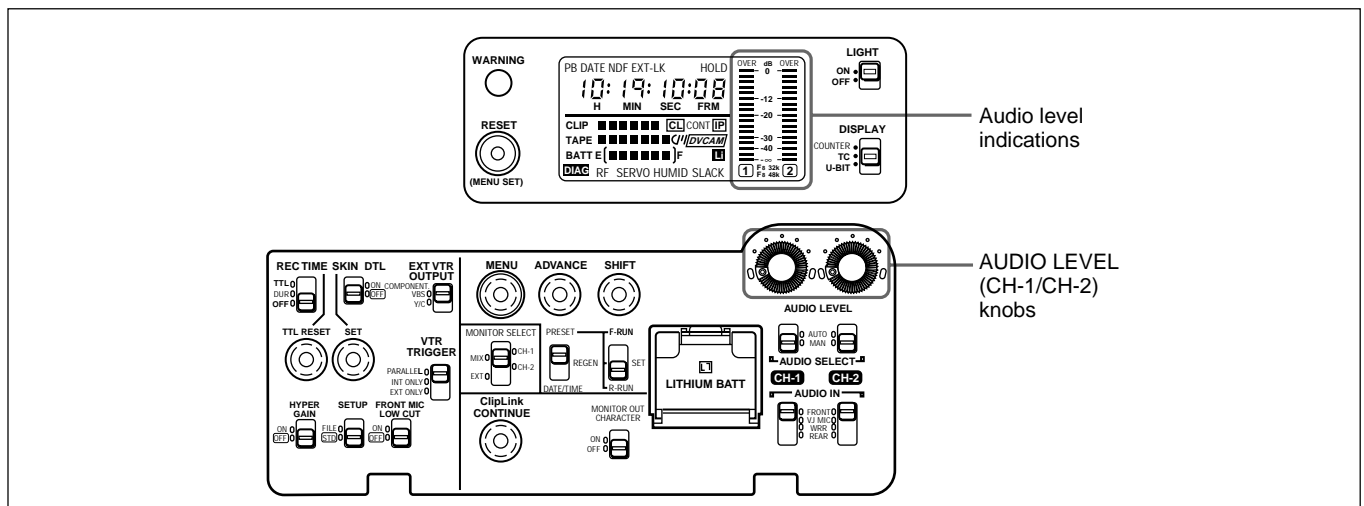

When the battery is getting exhausted

When the battery is getting exhausted, the BATT indication in the display window blinks once a second. (see page 17.) Replace the battery with a charged battery immediately.

If you continue to use the low battery, the BATT indication will blink four times a second, and the operation will stop.

For description of how to replace batteries, see "Power Supply" on page 46.

Notes

- Turn the POWER switch OFF before replacing the battery.
- If using two NP-1B batteries, be sure to replace both batteries at the same time.

Recording an External Video Signals

When the optional DSBK-501/501P Analog Composite Input Board is fitted to this camcorder, you can record the external video signals.

- 1 Connect the external video signals to the GEN LOCK IN/VIDEO IN connector.
- 2 Set VIDEO IN to EXT using the basic menu page 4.

For details, see "Viewfinder Basic Menu" on page 81.

- 3 Press the EJECT switch to open the cassette holder, and insert the cassette.
- 4 Press the VTR button on the camcorder or lens.

The camcorder starts recording.

Notes

- If the external video signals include noise, such as jitter, the camcorder may not record signals properly.
- When recording the external analog video signals, signals are not output from the S VIDEO OUT connector.
- Setup log data is not displayed when external analog video signal are being recorded (see page 101.).

Recording on an External VCR Using the VTR Connector (26-pin)

Set the VTR TRIGGER switch in the following way. (You can change the setting during recording.)

Simultaneous recording on the external and internal VCR: PARALLEL

Recording on the external VCR: EXT ONLY

When the VTR TRIGGER switch is set to INT ONLY, the camcorder controls only the internal VCR even if an external VCR is connected.

For information about connectable VCRs, see "Connecting an External VCR" (page 45).

Recording on the internal and external VCRs simultaneously

- 1 Set the switches as shown in the table below.

Switch	Setting
VTR TRIGGER switch	PARALLEL
EXT VTR OUTPUT switch	Set depending on the connected VCR.
Audio input level setting switch on the connected VCR	-20 dB

- 2 Put the external VCR in the recording pause mode.
- 3 Press the VTR button on the camcorder or lens.

The both VCRs start recording simultaneously.

To pause recording, press the VTR button on the camcorder or lens again. The both VCRs go into the recording paused state.

If either VCR comes to the end of tape during recording, one VCR stops at the end of the tape, and the other will continue recording.

To restart simultaneous recording, perform the following.

When the internal VCR has run out of the tape: Change the cassette, and press the VTR button on the camcorder or lens.

When the external VCR has run out of the tape: Change the cassette, and start recording with the controls on the external VCR.

Note

After replacing the cassette on the external VCR, do not press the VTR button on the camcorder or lens, as this will pause the internal VCR.

To operate either VCR during recording, change the VTR TRIGGER switch setting. Both VCRs continue recording at the time of switching.

Setting to INT ONLY: The camcorder can operate only the internal VCR.

Setting to EXT ONLY: The camcorder can operate only the external VCR. If you set REC TIME to EXT in the advanced menu page 4, you can change the total recording time (TTL) from of the internal VCR to the one of the external VCR.

Recording on an External VCR Using the DV OUT Connector

You can record digital audio and video signals in the DV format on an external VCR, using the DV OUT connector.

For information about connectable VCR, see “Connecting an External VCR” on page 45.

Note

When an external equipment, such as VCR, is connected to the DV OUT connector, the ClipLink and the audio fade-in/fade-out function during recording will not work.

Recording on the external VCR only

- 1** Set the VTR TRIGGER switch to EXT ONLY.
- 2** Use the controls on the external VCR to put it in the recording paused state.
- 3** Press the VTR button on the camcorder or lens.

The external VCR starts recording.

To pause recording

Press the VTR button on the camcorder or lens again.

Using the viewfinder to see playback pictures

For the internal VCR: Press the PLAY button.

For the external VCR: Press the RET button on the lens when the internal VCR is in recording or no cassette is inserted in the internal VCR. While holding it down, you can see the return video from the external VCR.

Back Space Editing

This section describes the steps for recording several scenes continuously.

- 1 Follow steps **1** to **5** (pages 53 to 55) in the procedure “Recording on the Internal VCR” to begin recording.

To continue the time code that has been recorded on the tape, set the TC mode switch 2 to R-RUN in step **3** (page 54).

For details of time codes, see “Setting the Time Code Value” on page 64.

- 2 When you have finished recording a scene, press the VTR button on the camcorder or lens.

This pauses the recording operation.

Note

Do not do any of the following before the next scene is shot as it will interrupt the recording (the recording will not be continuous).

- Remove the cassette.
- Transport the tape (play, rewind, fast forward).
- Press the STOP button.
- Replace the battery when the camcorder is powered.

- 3 When you are ready to shoot the next scene, press the VTR button on the camcorder or lens again.

This restarts the recording operation.

- 4 Repeat steps **2** and **3** for each scene to be shot.

Operation	Step
Restart an interrupted recording (see step 2 above)	See next section “Starting Back Space Editing at Any Tape Position”.
Check the recorded contents	See “Checking the Recorded Contents Immediately After Shooting —Recording Review” on page 61.
Stop recording	Press the VTR button on the camcorder or lens, then press the STOP button.

If there is a long period before shooting the next scene

Once put the camcorder into recording pause mode, it waits a certain (user-definable) period of time and then automatically switches to standby-off mode. When the camcorder is in standby-off mode, it takes time for the recording to start after pressing the VTR button.

For details on setting the timeout value for automatic switching to standby-off mode, see “Menu 207 Setting Standby-On Period” on page 106.

Starting Back Space Editing at Any Tape Position

This section describes the steps for insert a new scene at any desired position on the tape.

The following steps can also be used to restart recording after an interruption has occurred.

- 1 Perform step **1** (page 53) in “Recording on the Internal VCR”.
- 2 Insert the cassette containing the previous recording.
- 3 Perform steps **3** and **4** (pages 54 and 55) in “Recording on the Internal VCR”.

To continue from the last time code of the previous recording, set TC mode switch 1 to REGEN.

For details about time codes, see “Setting the Time Code Value” on page 64.

- 4 Press the PLAY button.

The recorded contents are displayed on the viewfinder screen.

Operation at playback	Step
Fast forward the tape	Press the F FWD button.
Rewind the tape	Press the REW button.

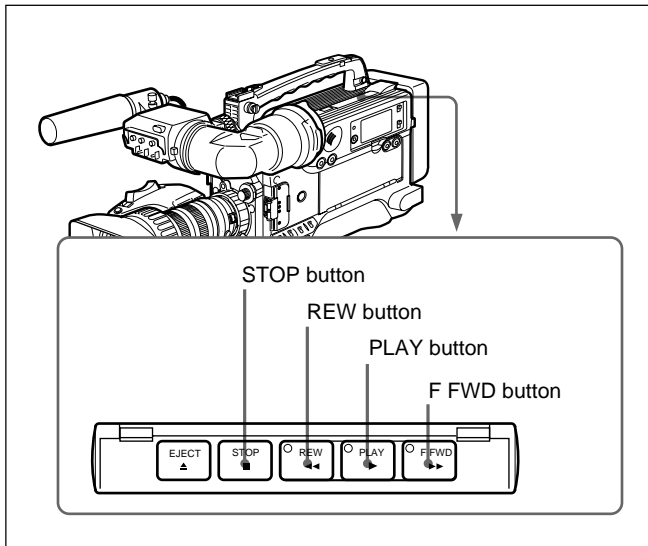

- 5** Press the STOP button when the tape reaches the position where the new recording will start (*see the figure above*).

This stops the tape.

- 6** Press the RET button on the lens.

This rewinds the tape slightly and runs it until the continue point (specified by step 5), then sets the camcorder to recording pause state.

- 7** Press the VTR button on the camcorder or lens.

This starts recording.

The edit search function enables you to search for the continue position. For details, see next section.

Note

If you turn the POWER switch off during recording, or when recording is paused, the camcorder automatically goes through its shut-down sequence, then powers off. When you next turn the POWER switch on, the camcorder automatically finds the point at which recording ended, and sets itself up so that you can carry in with continuous recording. Note that this operation takes several seconds: do not turn the POWER switch off or replace the battery during this interval, as the automatic recording continuity will be lost.

Note also that the recording continuity is lost in the following cases.

- If the POWER switch is turned on and off repeatedly.

- If the camcorder is left powered off for several hours.
- If the camcorder is subject to severe vibration while powered off.
- If for any other reason the automatic recording continuity function is unable to operate correctly.
- If the lithium battery (CR2032) is exhausted, or if no lithium battery has been fitted.

Using the Edit Search Function While Back Space Editing

You can use the edit search function to find the desired tape location when continuing to record from any other location on the tape. Press and hold one of the EDIT SEARCH buttons to activate the search playback function for as long as you hold down it.

- 1** Turn on the power, then insert a cassette into the VCR.
- 2** Perform steps **2** to **12** in “Basic Procedure for Shooting” (*pages 49 and 50*).
- 3** Press and hold either of the EDIT SEARCH buttons (REV or FWD).

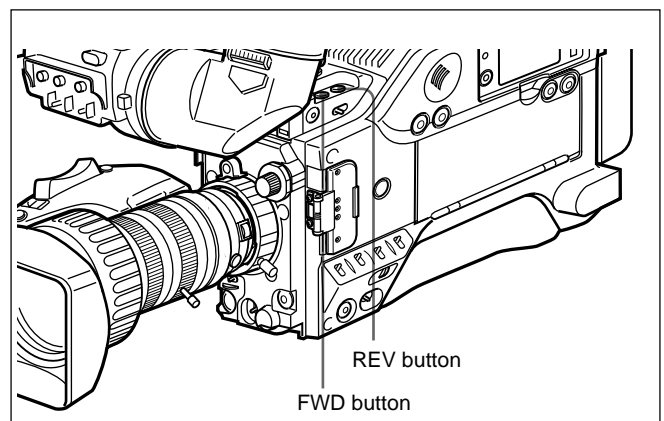

The tape is moved in reverse or forward search mode for as long as you hold down the REV or FWD button, and the image is shown in the viewfinder.

(Continued)

Back Space Editing

To change the playback speed

Press the REV or FWD button down firmly into the inner position to make the tape move at the faster speed. Press the button down lightly to make the tape move at the slower speed.

Note

Do not shut off the power while using the edit search function. The VCR may not be able to find the continue point.

- 4 Release the REV or FWD button when you find the tape location where you wish to continue shooting.

The VCR enters recording pause mode.

- 5 Press the VTR button on the camcorder or the lens.

The VCR starts recording.

Using the Freeze Mix Function

The freeze mix function superimposes a freeze-frame image of a previously recorded shot on the shooting image displayed on the viewfinder screen.

You can use this function to easily frame a subject within the same framework from a previous shot.

Note

When the camcorder is in EZ mode, the freeze mix function is disabled. Press the EZ MODE button to release the EZ mode beforehand. (See page 14.)

- 1 Connect a color monitor to the MONITOR OUT connector and set the MONITOR OUT CHARACTER switch to ON. (It is not necessary to set the MONITOR OUT CHARACTER switch to ON when using only the viewfinder for freeze mix operation.)
- 2 Perform steps 2 to 10 from “Basic Procedure for Shooting” (pages 49 and 50).
- 3 Play back the tape on which the image to be used for framework alignment has been recorded, and press the MENU switch to ON position.

The following indication appears on the screen.

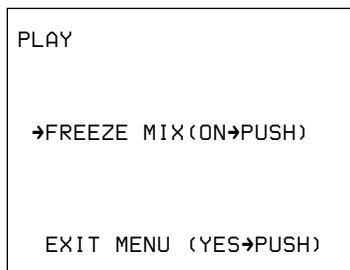

For details of the playback operation, see page 61.

- 4 Press the MENU dial when you see the image you want to freeze.

The frozen playback image is displayed, mixed with the shooting image, in monochrome. The indication “FREEZE MIX ON” appears on the screen.

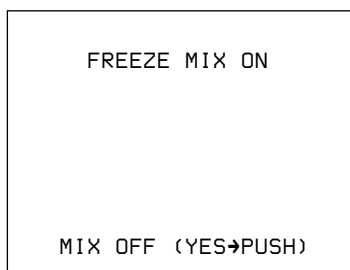

To release the freeze mix mode, press the MENU dial again.

To change the freeze-frame image

Press the PLAY button.

Use the tape transport buttons to find the desired image and then perform step 4 again.

- 5 Once you have framed your subject, press the MENU dial to cancel the freeze mix function.
- 6 Find the recording start point or insert a new cassette for recording, then begin recording.

Notes

- If you use the tape transport buttons during back space editing, the back space editing mode will be stopped. When you were using the ClipLink function at shooting, if you simply restart the recording you will lose any ClipLink data that was recorded. To avoid this, press the ClipLink CONTINUE button before restarting recording.
- The signal is not output from the DV OUT connector while using the freeze mix function.

Playback — Checking Recorded Contents

Checking the Recorded Contents Immediately After Shooting — Recording Review

Immediately after shooting, you can use the recording review function to automatically rewind and play back the last 2 to 10 seconds of the recording to check the recorded contents.

Performing recording review

With recording paused, press the RET button on the lens.

Depending on how long you hold down the button, the tape is automatically rewound over the last 2 to 10 seconds of the recording, and then this last part of the recording is shown in the viewfinder. You can also listen to the recorded sound via an earphone or the speaker. After the recorded part is played back, the camcorder is automatically returns to the pause state.

Notes

- During recording review, do not turn the POWER switch off. The camcorder may not be able to find the continue point.
- If you press the VTR button on the camcorder or lens during recording review, the camcorder stops the recording review and starts recording. In this case (when ClipLink mode is OFF), it is impossible to start back space editing.

Viewing Monochrome Playback in the Viewfinder

You can view a monochrome playback of the recording in the viewfinder.

- 1 Turn the power on.
- 2 Load a cassette.
- 3 Press the PLAY button.

This starts playback, during which a monochrome playback of the recording is shown in the viewfinder.

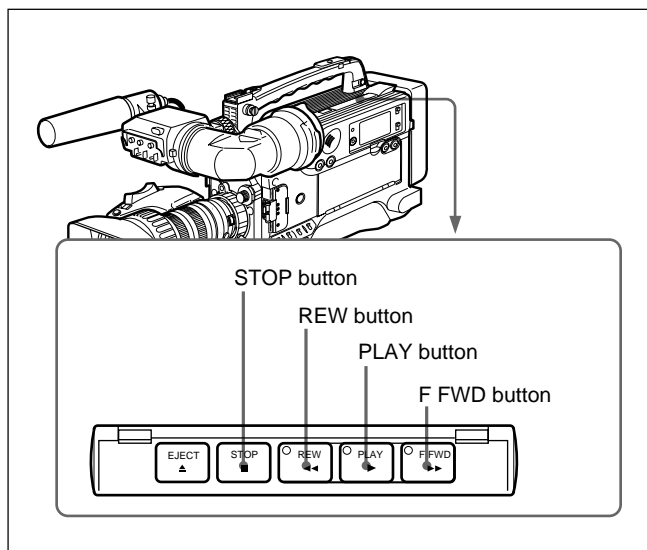

Operation	Step
Fast forward the tape	Press the F FWD button.
Rewind the tape	Press the REW button.
Stop the tape	Press the STOP button.

Note

If two or more series of Index Pictures are recorded separately on the tape, they may be played back at back space editing points.

For details about Index Pictures, see “ClipLink Shooting” (page 68).

Viewing Color Playback

Using a color television or color video monitor, you can view a color playback (with no playback adaptors).

Connect a color television or color video monitor to the MONITOR OUT connector or the S VIDEO OUT connector.

See the previous section “Viewing Monochrome Playback in the Viewfinder” for playback operation.

Setting Time Values

The camcorder uses three types of time values: counter values, time code values, and user bits.

The time value is displayed in the viewfinder screen and in the display window.

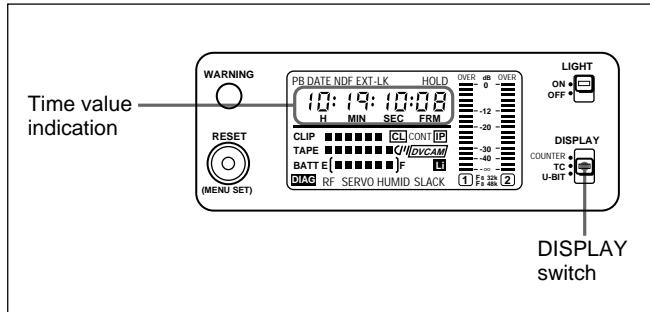

Use the DISPLAY switch to switch time value indications.

Type of time value	DISPLAY switch setting
Counter of tape transport time	COUNTER
Time code	TC
User bits	U-BIT

Note

The time code and user bits cannot be displayed properly if the tape does not have time code and/or user bits recordings or if the time code was recorded using a non-compatible method.

For details of the time value indication in the viewfinder, see page 76.

Resetting the counter

The counter value shows the tape's running time in hours, minutes, and seconds format. Before starting a tape, perform the following steps to reset the counter.

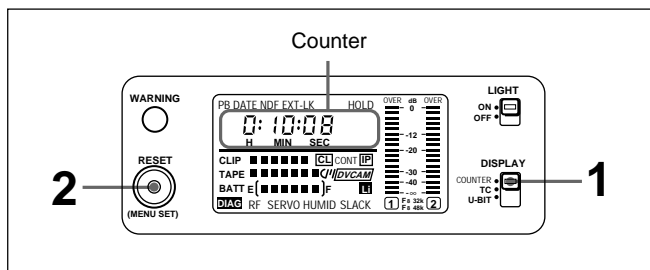

1 Set the DISPLAY switch to COUNTER.

The time value indication in the display window shows the current counter value.

2 Press the RESET/(MENU SET) button.

This resets the counter shown in the viewfinder and display window as "0:00:00".

The counter value starts advancing as the tape is transported. It shows negative values if the tape is rewound past the point where the counter was reset.

Note

Discontinuous recording in the tape may cause the counter to malfunction during playback.

Displaying the date/time

The camcorder automatically records the real time of the built-in clock on the tape in addition to time codes and video/audio signals.

Perform the following steps to display the date or time instead of the time value.

1 Confirm the following.

Parts to confirm	State
Display window	The VCR menu is not displayed.
TC mode switch 1/2	Set to the position other than PRESET/SET.

2 Set the DISPLAY switch to TC or U-BIT.

3 Press the SHIFT button.

While pressing the SHIFT button, the date or time is displayed at the location of the time value indication.

DISPLAY switch setting	Indication
TC	Time
U-BIT	Date

For description of how to set the built-in clock, see "Menu 101 Setting the Real Time Clock and Calendar" on page 105.

Setting the User Bit Value

You can set the user bits as eight-digit hexadecimal values (base 16) to have the date, time, scene number, and other information inserted into the time code. When using both the time code and user bits, **set up the user bits first**. If you set the time code first, the internal time code generator will remain stopped while you set the user bits, which will set the time value off from the original setting.

Note
Setting the user bit value may be disallowed in some cases at ClipLink shooting. For details, see step 4 on page 69 in “ClipLink Shooting”.

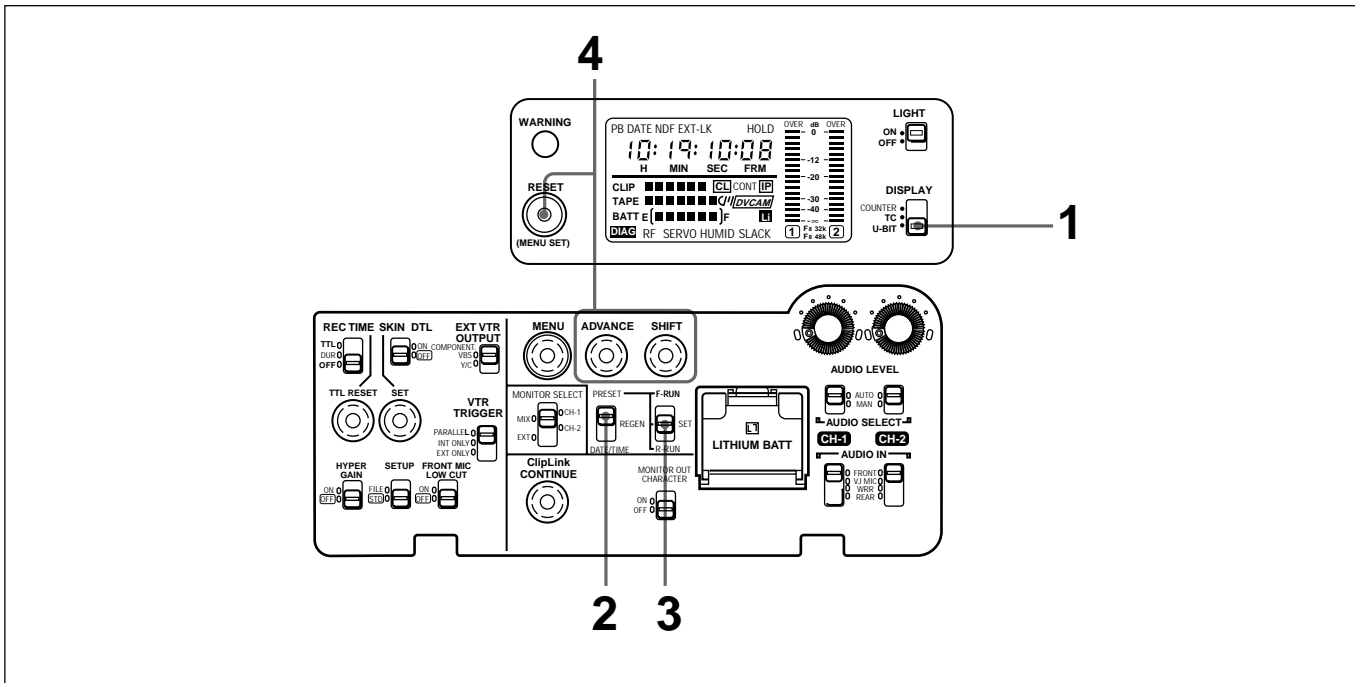

- 1** Set the DISPLAY switch to U-BIT.
The user bits indication appears.
- 2** Set the TC mode switch 1 to PRESET.
- 3** Set the TC mode switch 2 to SET.
This causes the leftmost digit in the user bits indication to start blinking.
- 4** Set the user bits.

Operation	Step
Select a digit	Press the SHIFT button. Each time you press the SHIFT button, the next digit to the right starts blinking.
Change a value	Press the ADVANCE button. Each time you press the ADVANCE button, the displayed value is incremented to F and returns to 0.
Reset	Press the RESET/(MENU SET) button. The display returns to “00 00 00 00”.

Hexadecimal digits A to F are displayed as follows.

Hexadecimal digit	A	B	C	D	E	F
Display	<i>f</i>	<i>b</i>	<i>c</i>	<i>d</i>	<i>e</i>	<i>f</i>

- 5** Perform step 6 in “Setting the Time Code Value” on page 65.

Setting the Time Code Value

This section describes the steps for setting time code recording methods for particular shooting conditions and setting initial values.

When using both the time code and user bits, **set up the user bits first**. If you set the time code first, the internal time code generator will remain stopped while you set the user bits, which will set the time value off from the original setting.

For details of setting user bits, see “Setting the User Bit Value” on previous page.

Note

Setting the time code value may be disallowed in some cases at ClipLink shooting. For details, see step 4 on page 69 in “ClipLink Shooting”.

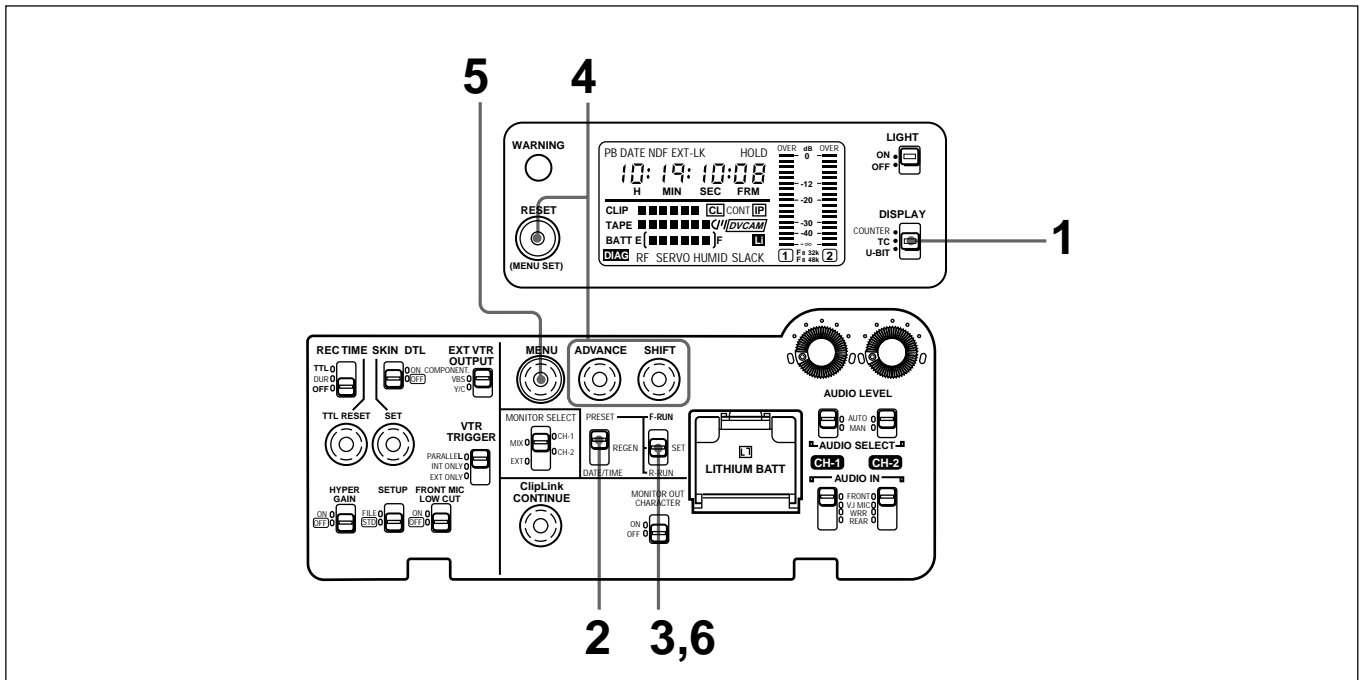

1 Set the DISPLAY switch to TC.

2 Set the TC mode switch 1 to PRESET.

3 Set the TC mode switch 2 to SET.

This causes the leftmost digit in the time code display to start blinking.

4 Set the time code initial value.

The time code value can be set anywhere in the range of “00:00:00:00” to “23:59:59:29” (DSR-500WSL) or “23:59:59:24” (DSR-500WSPL).

5 For the DSR-500WSL, use menu 204 to select the frame mode.

Operation	Step
Select a digit	Press the SHIFT button. Each time you press the SHIFT button, the next digit to the right starts blinking.
Change a value	Press the ADVANCE button. Each time you press the ADVANCE button, the displayed value increases.
Reset	Press the RESET/(MENU SET) button. The display returns to “00:00:00:00”.

Operation	Step
Adjust the discrepancy between time code value and real time	Select the drop-frame mode.
Need not adjust the discrepancy between time code value and real time	Select the non-drop-frame mode.

For more information about the drop-frame/non-drop-frame mode, see “Drop-frame mode (for DSR-500WSL Only)” on next page.

For details of menu operations, see page 105.

- 6** Use the TC mode switch 2 to set the desired running mode.

Operation	Setting
Time code advances freely regardless of the VCR's current operation mode.	F-RUN
Time code value advances only while recording.	R-RUN

If you select F-RUN, the time code starts advancing immediately.

Drop-frame mode (for DSR-500WSL only)

In the NTSC standard, the time code value is based on 30 frames per second, but the exact video frame frequency is in fact 29.97 frames per second and the real time, or 18 frames per 10 minutes.

Drop-frame mode corrects for this by skipping two frame counts at the beginning of every minute which is not a multiple of ten.

Example: When the minute value is changing from 11 to 12

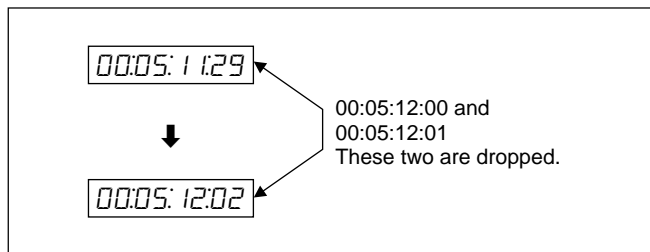

In non-drop-frame mode, however, no frame counts are omitted, and there is a gradual deviation of the time code from real time.

Making the time code continuous at back space editing

Set the TC mode switch 2 to R-RUN and start back space editing.

For operation of back space editing, see "Back Space Editing" on page 58.

Restarting an interrupted recording

Perform the following steps to make the time code continuous when the recording has been interrupted or when the cassette tape has been removed from the camcorder between shootings.

- 1** Set the TC mode switch 1 to REGEN.

Time code advance is automatically set to R-RUN even if the TC mode switch 2 has been set to F-RUN.

- 2** Perform steps **1** to **6** of "Starting Back Space Editing at Any Tape Position" on pages 58 and 59.

When the camcorder is at the recording pause state, the recorded time code is read from the tape and synchronized to the internal time code generator.

- 3** Press the VTR button on the camcorder or lens to restart back space editing.

Setting the time code to the real time clock bU calendar

Set the TC mode switch 1 to DATE/TIME.

You can record the real time set in menu 101 as the time cord, and the calendar set in menu 101 as the user bits.

Once you set this switch to DATE/TIME position, it is not possible to retrieve the previous value (user bits and time code) in the time code generator.

For how to set the real time clock and calendar, see "Menu 101 Setting the Real Time Clock and Calendar" on page 105.

Synchronization With External Time Code Signals — Gen-Lock

To edit and compile a recording that is shot using multiple camcorders, it is necessary to synchronize the video and time code of the various camcorders (by gen-lock).

Note

Synchronization with external time code signals (by gen-lock) may be disallowed in some cases at ClipLink shooting. For details, see step 4 on page 69 in “ClipLink Shooting”

Connection for gen-lock

Connect the reference video and time code signals to the camcorder as shown below.

Locking the video and time code signals to an external reference signal

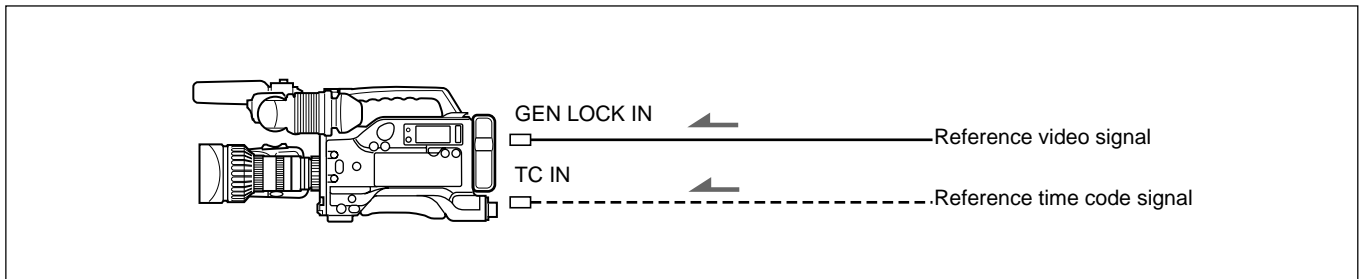

Locking the video and time code signals to another camcorder's video and time code signals

Using one camcorder as reference, to its video and time code signals, lock the other camcorders' video

and time code signals.

If the reference camcorder is gen-locked to an external reference signal, any other connected camcorders are gen-locked to the same reference signal.

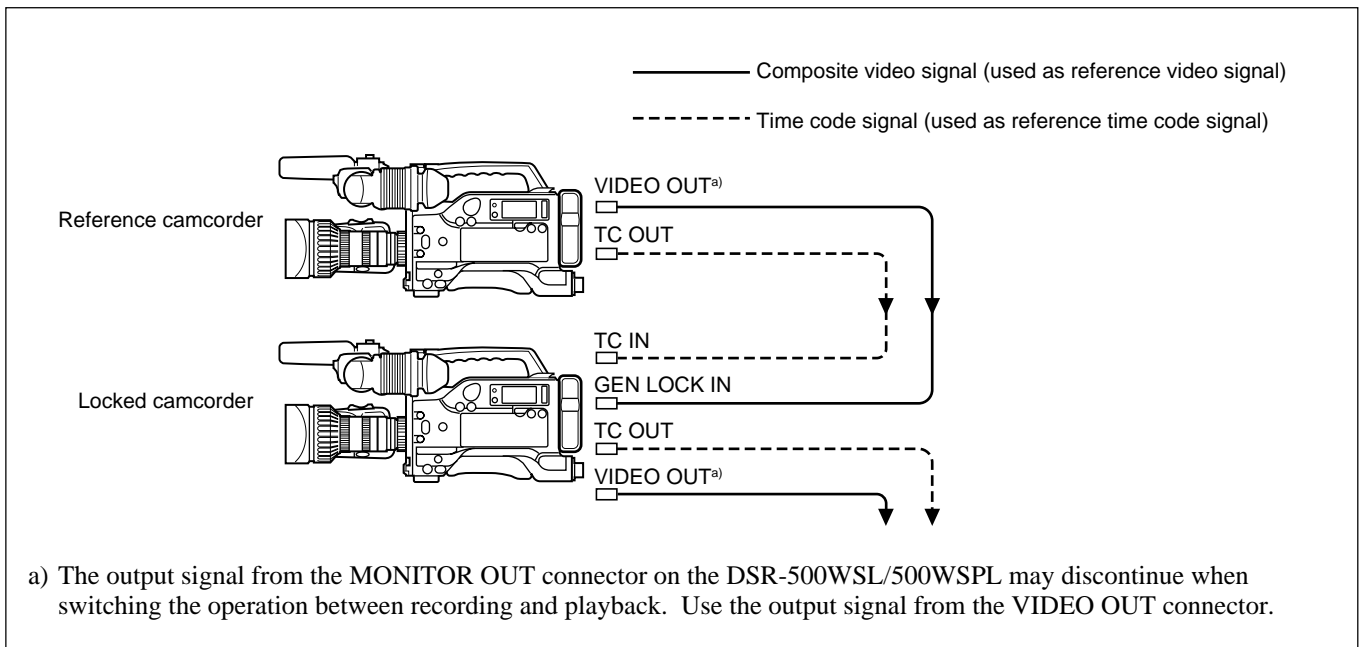

Locking the internal time code generator to the reference time code

Perform the following steps to synchronize the camcorder's internal time code generator to an external time code.

- 1** Set the TC mode switch 1 to PRESET.
- 2** Set the TC mode switch 2 to F-RUN.
- 3** Connect a reference time code and video signal to the camcorder.

For connections, see the previous section "Connection for gen-lock".

"EXT-LK" will be displayed in the display window. The internal time code generator will maintain its externally synchronized state even after you disconnect the reference time code signal. The precision of this synchronization (phase alignment) of time codes depends on the precision of the camcorder's sync signal generator.

Notes

- After setting up external synchronization, allow a few seconds for the camcorder's sync signal generator to stabilize before recording.
- Only the time code can be externally synchronized. User bits cannot be externally synchronized.
- If you turn the POWER switch on or off while the camcorder is operating under external synchronization, synchronization precision will be reduced.

ClipLink Shooting

The ClipLink function is intended to be used at various stages from recording to editing. When you record using this function, Index Pictures are automatically recorded along with the time code, scene number, and other data, all of which make for more efficient editing.

For an overview of the ClipLink function, see “What Is ClipLink?” on page 136.

To record Index Picture, the optional DSBK-301A Index Picture Board is required.

For detail of fitting the optional DSBK-301A, refer to the instruction manual supplied with it.

Notes

- When an external equipment, such as VCR, is connected to the DV OUT connector, you cannot shoot with ClipLink.
- On the DSR-500WSL/500WSPL, you can also use the ClipLink function without recording Index Pictures. However, if you perform ClipLink shooting on the DSR-500WSL/500WSPL without fitting the optional DSBK-301A, the recorded tape may cause malfunction at ClipLink continue on the DSR-1/IP. When you perform ClipLink shooting in a system containing the DSR-1/IP and DSR-500WSL/500WSPL, fit the optional DSBK-301A Index Picture Board to the DSR-500WSL/500WSPL.

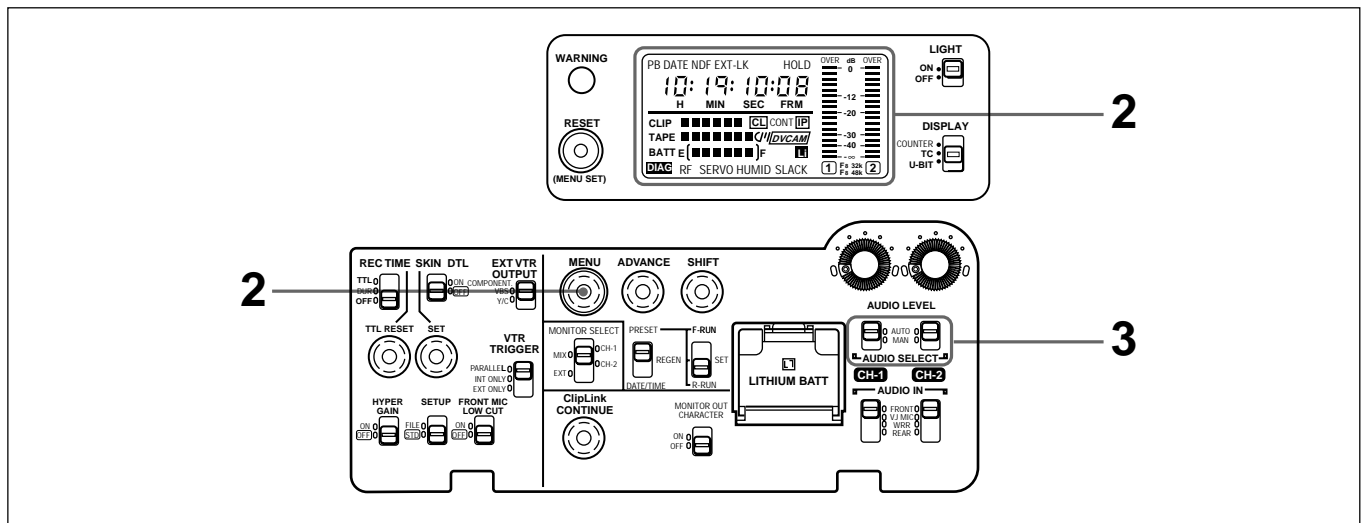

1 Turn the power on and perform steps **2** to **10** in “Basic Procedure for Shooting” (pages 49 and 50).

2 Perform the first two steps (page 53) in “Recording on the Internal VCR”. Check the following points.

Check point	Method
Check the ClipLink function is on (or set it to on).	See “Menu 211 Selecting the ClipLink Function” under “VCR Menu Operation” (page 109).
Check whether or not the cassette includes cassette memory. (The camcorder supports cassettes with up to 16 Kbits of cassette memory.)	C// appears in the display window when the loaded cassette includes cassette memory. (The ClipLink function cannot be used unless C// appears in the display window.)
Make sure that the lithium battery has been correctly inserted and is not used up.	L appears in the display window if the lithium battery has not been inserted or is used up.

CLIP and **IP** appear in the display window.

Display	Meaning
CLIP	The camcorder is in ClipLink mode.
IP	The camcorder is in ClipLink mode and can record Index Pictures (when the DSBK-301A is fitted).

The following display appears on the viewfinder screen.

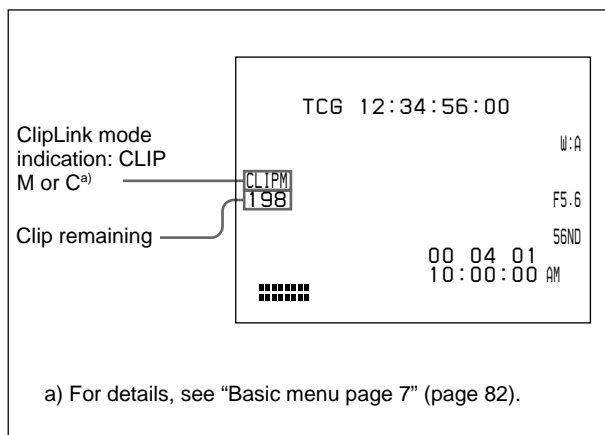

To record the cassette name/number

Access basic menu page 7 to specify a name or number for the inserted cassette (*see page 82*).

Notes

- If you use a cassette that contains data recorded via a different VCR, when you enter a cassette name/number in the cassette memory, you may lose any data that was previously written to the cassette memory. Also, if you use a cassette that contains data recorded in ClipLink mode on the camcorder for recording on a different VCR, you may lose any data that was previously written to the cassette memory.
- When you power the camcorder or insert a cassette, black squares (■) blink in the place of the clip remaining indication in the display window (during this, the cassette memory data is being checked). Start recording after the blinking ends, or the ClipLink function will be disabled.
- When **CL** appears in the display window, it means that data has already been recorded into the cassette memory. If you record under this condition whether the ClipLink function is available or not, the existing cassette memory data will be overwritten. To avoid this, you can either insert a new cassette or follow the procedure for appending cassette memory data, as described in the section "Resuming Recording in ClipLink Mode" (*page 72*). If the **CL** is flashing, it means abnormality of the cassette memory. In this case, it is impossible to continue recording from that data on ClipLink mode.
- The number of recordable clips varies with cassette memory capacity. Up to 45 clips (Index Pictures) can be recorded in a 4-Kbit cassette

memory and up to 198 clips (Index Pictures) can be recorded in a 16-Kbit cassette memory.

- 3 Set the AUDIO SELECT (CH-1/CH-2) switch to AUTO or MAN (*see page 54*).
- 4 Press the VTR button on the camcorder or the lens.

Recording begins when the TALLY indicator stays lit after blinking for a moment.

The camcorder enters ClipLink continue mode (in which back space editing is possible using ClipLink function) and indication CONT appears in the display window.

During recording, the time code (HH:MM:SS format) at the recording start (Rec IN) point is recorded into the camcorder's internal memory. Index Pictures are also recorded if you use the DSBK-301A.

Note

When CONT appears, regardless of the setting of the TC mode switch 1, the time code generator automatically enters REGEN mode. Consequently, you cannot freely specify a time code nor can you use the external synchronization (genlock) function.

- 5 To stop recording, press the VTR button on the camcorder or the lens.

This sets recording pause mode.

The time codes (HH:MM:SS) for the current clip (contents between the Rec IN and Rec OUT points) are recorded along with the scene number (as scene 001) in the cassette memory. The last Index Picture in the recorded scene is also recorded when the DSBK-301A is fitted.

Note

While data is being recorded in the cassette memory, cutting the power supply or opening the cassette holder is disallowed. If you turn the POWER switch off or press the EJECT button, black squares (■) blink in the place of the clip remaining indication in the display window. When the data has been recorded, the power supply is cut or the cassette is ejected.

(Continued)

To continuously record the next scene

Repeat steps 4 and 5.

The scene number will be automatically incremented from the previous number.

You can set or clear an “NG” designation for the previously recorded scene before shooting the next scene.

If you have stopped the recording, see “Resuming Recording in ClipLink Mode” (page 72).

Notes

- During recording pause, pressing the STOP/PLAY/FWD/REW buttons, performing edit search, or ejecting the cassette will interrupt the ClipLink shooting. With this state, it is impossible to start back space editing using ClipLink function. (The ClipLink continue mode is canceled and indication CONT in the display window disappears.) To perform back space editing at the recording stop position, press the ClipLink CONTINUE button before resuming recording. If you do resume recording without pressing this button first, the previous recorded data (and Index Pictures) will be overwritten or otherwise invalidated.
- Each time you press the STOP button, the number of remaining clips is decremented by one. If you resume recording with the same VCR, the number of remaining clips is automatically incremented by one.

For details, see “Resuming Recording in ClipLink Mode” (page 72).

- Do not unplug the power supply connector (connected to a battery pack or AC outlet) while the POWER switch is still set to ON, as this may cause the ClipLink function to operate abnormally. Be sure to set the POWER switch to OFF before disconnecting the power supply.

Setting Editing Points While Shooting

You can use the TAKE button to record a time code for a Cue point or a Mark IN/OUT point.

Setting Mark IN/OUT points as you shoot

The following data is recorded onto the cassette when you specify Mark IN/OUT points while shooting continuously at length, instead of during linked recording of each scene.

- Time codes (HH:MM:SS) for specified Mark IN/OUT points
- Scene number: The scene number counter is automatically incremented with each Mark IN point specification.
- NG specification, cassette name/number
- Index Pictures for all Mark IN points (when the DSBK-301A is fitted): these are recorded each time recording is stopped.

Note

The time codes for Rec IN/OUT points are not recorded.

Perform the following procedure.

- 1** Perform steps 1 to 3 in “ClipLink Shooting” (pages 68 and 69).
- 2** Access basic menu page 7 and perform the following operations.
 - 1)** Set MARK/CUE to MARK.
The ClipLink mode indication “CLIP M” appears on the viewfinder screen.
 - 2)** Set the cassette name or number if necessary.
- 3** Press the VTR button on the camcorder or lens.

For details of menu operations, see “Basic Menu Operations” (page 80).

The camcorder starts recording, and the REC/TALLY indicator(s) light(s) in the viewfinder.

- 4** Press the TAKE button when you find a shot where you would like to set a Mark IN point.

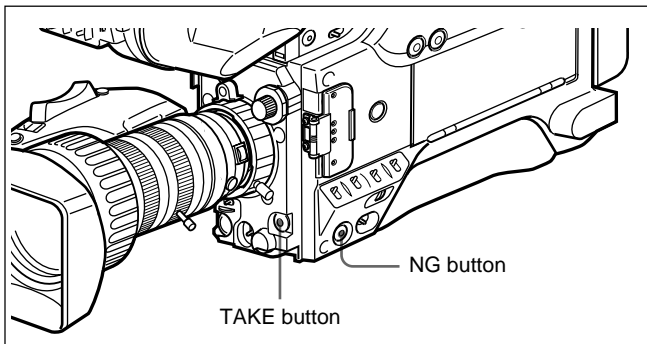

The TAKE/TALLY indicator (orange) lights in the viewfinder and “TAKE” appears on the screen.

- 5** Press the TAKE button when you find a shot where you would like to set a Mark OUT point.

The TAKE/TALLY indicator (orange) goes out in the viewfinder and the “TAKE” disappears from the screen.

At this time, the time code (HH:MM:SS) at the Mark IN/OUT point for scene 001 is recorded to the camcorder’s internal memory, and then recorded to the cassette memory.

To set/clear NG

If you press the NG button before you set the next Mark IN point, the previous scene will be designated as “NG” (“NG” appears on the viewfinder screen or the screen).

Once NG has been set, you can cancel it by pressing the NG button again before you set the next Mark IN point (the “NG” on the screen disappears).

- 6** Repeat steps **4** and **5** as needed to record time codes at Mark IN/OUT points, scene numbers, and NG designations to cassette memory.

The scene number is automatically incremented each time you specify a Mark IN point.

- 7** To finish shooting, press the VTR button on the camcorder or the lens.

This stops the recording operation.

The Index Pictures of each Mark IN point are recorded onto the tape (when the DSBK-301A is fitted).

Setting Cue points as you shoot

The following data is recorded onto the cassette when you specify a Cue point to highlight a scene.

- Time codes (HH:MM:SS) for Rec IN/OUT points
- Time codes (HH:MM:SS:frame) for Cue points
- Scene number: The scene number is automatically incremented with each Rec IN point specification.
- NG designation, cassette name/number (if set from the camcorder)
- Index Pictures for all Rec IN points (when the DSBK-301A is fitted): these are recorded each time recording is stopped.

Perform the following procedure.

- 1** Perform steps **1** to **3** in “ClipLink Shooting” (pages 68 and 69).
- 2** Access basic menu page 7 and perform the following operations.
 - 1) Set MARK/CUE to CUE.
The ClipLink mode indication “CLIP C” appears on the viewfinder screen.
 - 2) Set the cassette name or number if necessary.

For details of menu operations, see “Basic Menu Operations” (page 80).

- 3** Press the VTR button on the camcorder or the lens.

The camcorder starts recording, and the REC/TALLY indicator lights in the viewfinder.

- 4** Press the TAKE button when you find a shot where you would like to set a Cue point.

The “CUE” indication appears (for about 1 second) on the viewfinder screen. At this point, the time code (HH:MM:SS:frame) at the Cue point is recorded into the cassette memory.

- 5** Repeat step **4** to specify more Cue points.

ClipLink Shooting

6 To finish shooting, press the VTR button on the camcorder or the lens.

This stops recording operation.

Time codes (HH:MM:SS) of recording start/stop points (Rec IN/OUT points) and scene number (scene 001) are recorded to the cassette memory and the Index Picture of the Rec IN point is recorded onto the tape (when the DSBK-301A is fitted).

Resuming Recording in ClipLink Mode

During recording pause in ClipLink mode, pressing the STOP/PLAY/F FWD/REW buttons, performing edit search, or ejecting the cassette will interrupt the ClipLink shooting. With this state, it is impossible to start back space editing using ClipLink function. (The ClipLink continue mode is canceled and indication CONT in the display window disappears.) If you resume recording on the same cassette, the previously recorded data will be overwritten.

You can avoid this and continue recording in ClipLink mode from the previous recording stop point by performing the following steps.

Note

If you stop recording during the first ten seconds of recording, you may not be able to use these steps to continue recording in ClipLink mode.

Chapter 3 Shooting

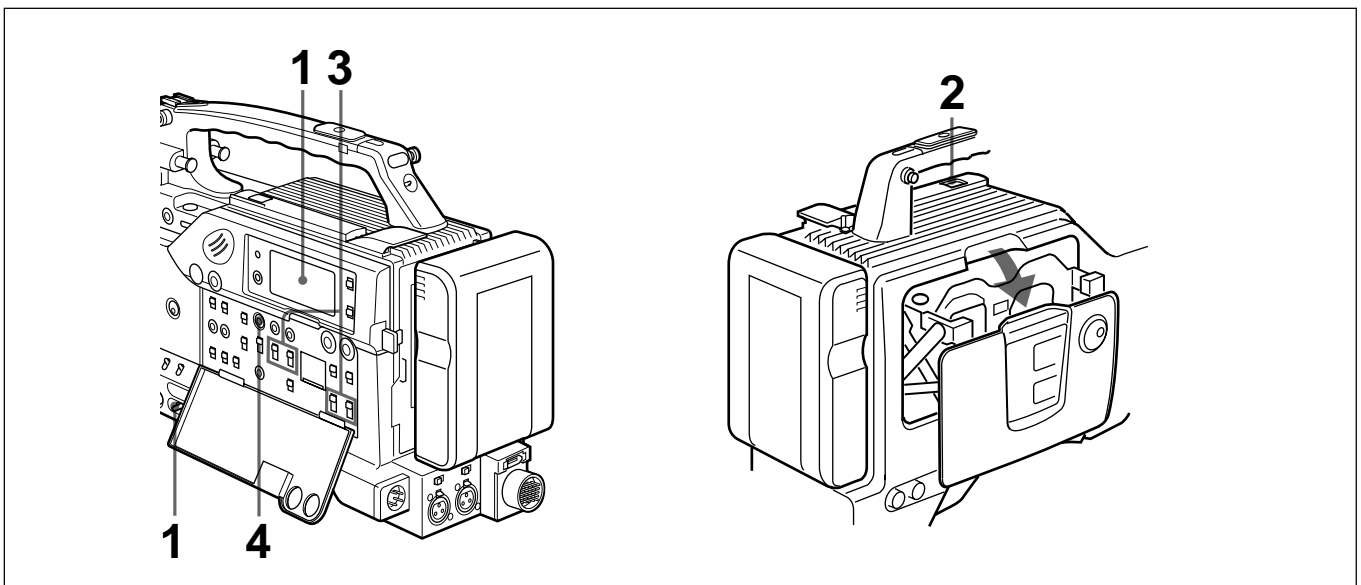

1 Perform steps **2** to **10** in “Basic Procedure for Shooting” (pages 49 and 50) and step **1** (page 53) in “Recording on the Internal VCR”.

2 Insert a cassette if one is not already loaded.

The **CL** and **C//** indications should appear in the display window.

Note

If the **CL** is flashing, it means abnormality of the cassette memory. In this case, it is impossible to continue recording from that data on ClipLink mode.

3 Check the following points.

Check point	Result and response
CLIP and IP (when the DSBK-301A is fitted) appear in the display window	If these indications do not appear in the display window, access the VCR menu and set ClipLink function to on (see page 109).
Remaining clips	Make sure there are enough capacity for recording clips (see page 18).

4 Press the ClipLink CONTINUE button.

The tape remaining indication in the display window flashes as the camcorder automatically searches the recording stop point. When it finds the recording stop point, it stops and enters recording pause mode.

Once it has stopped, check that the CONT indication appears in the display window.

To find the recording stop point efficiently

If you press the ClipLink CONTINUE button after rewinding or fast forwarding the tape to the position between the previous recording's start point and stop points, the recording stop point can more efficiently be found via an automatic search function.

If the recording stop point cannot be found, the CONT indication flashes in the display window.

5 Press the VTR button on the camcorder or the lens.

This starts the recording function.

6 When the recording is finished, set recording pause mode (or specify a Mark OUT point).

The time code (HH:MM:SS), scene number (serial number of scene during which recording was stopped) and other data for the current clip (contents between the Rec IN and Rec OUT points or between Mark IN and Mark OUT points) are recorded into cassette memory. The Index Pictures for the recorded scene are recorded after the recorded scene when the DSBK-301A is fitted.

Repeat steps 5 and 6 to start recording the next scene.

The Index Pictures are recorded onto the tape as described below when the DSBK-301A is fitted.

When all Index Pictures are recorded at the end of the recordings

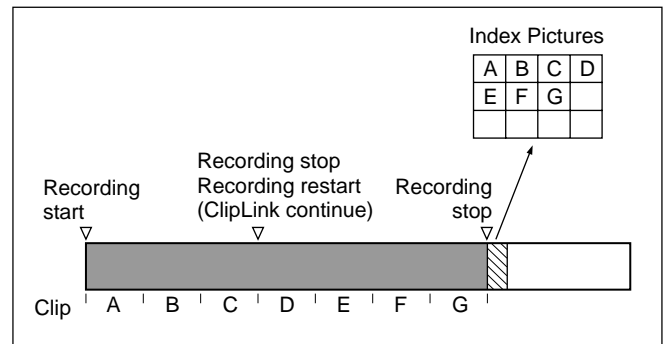

When two or more series of Index Pictures are separately recorded

Two or more series of Index Pictures may be recorded if ClipLink shooting is once interrupted due to ejecting the cassette and resumed (in case of changing the camcorder on resuming, for example).

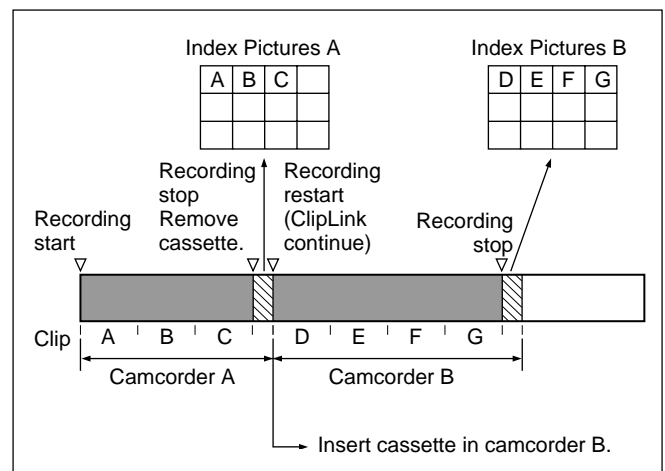

If there is no need for ClipLink continue

It is not necessary to press the ClipLink CONTINUE button when restarting recording.

See step 4 in the previous section "Resuming Recording in ClipLink Mode".

The contents recorded on the cassette may differ in this case depending on the settings when the recording is restarted.

ClipLink Shooting

When recording in ClipLink mode is started and previous recording is overwritten

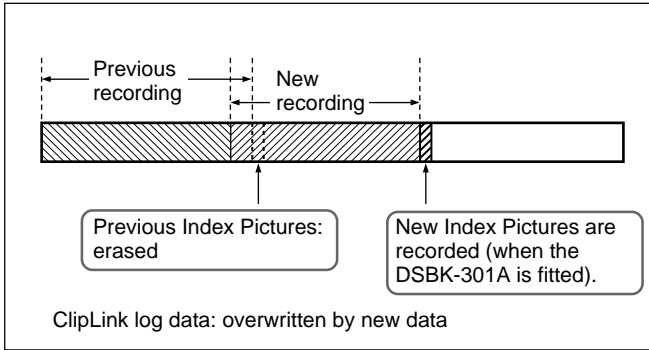

When recording in ClipLink mode is started after a previous recording

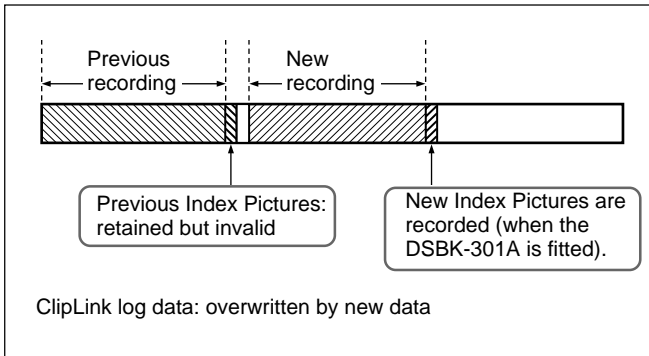

Viewfinder Screen Indications

There are four types of indication screen which appear in the viewfinder, as follows.

• **Normal indications**

These show the operating state of the camcorder. (See page 76.)

• **Status indications**

Pressing the MENU switch up while the normal indications are present calls a display of current settings. (See page 79.)

• **Basic menu**

This provides settings for the lens iris, shutter speed and so forth, and also a titling screen. (See the section "Viewfinder Basic Menu" on pages 80 to 85.)

• **Advanced menu**

This provides settings for the center marker, zebra pattern, viewfinder screen indications, and so forth. (See the section "Viewfinder Advanced Menu" on pages 86 to 92.)

Changing the Viewfinder Display

Use the dial and switches shown in the following figure to switch the viewfinder display among the normal indications, basic menu pages and advanced menu pages.

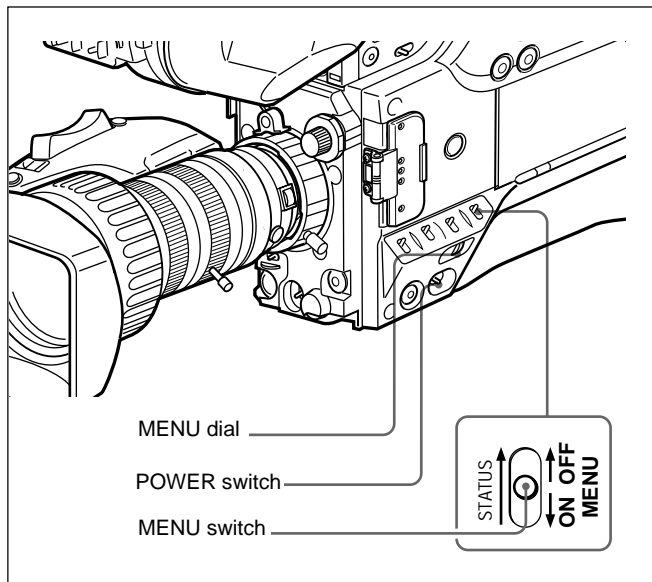

Displaying the normal indications and switching to the basic menu

To display the normal indications, move the POWER switch to the ON position.

To switch to and from the basic menu, use the MENU switch or MENU dial.

"CHECK DIAG" appears before basic menu page 1 when the self diagnostic function has detected an abnormality. (see page 85.)

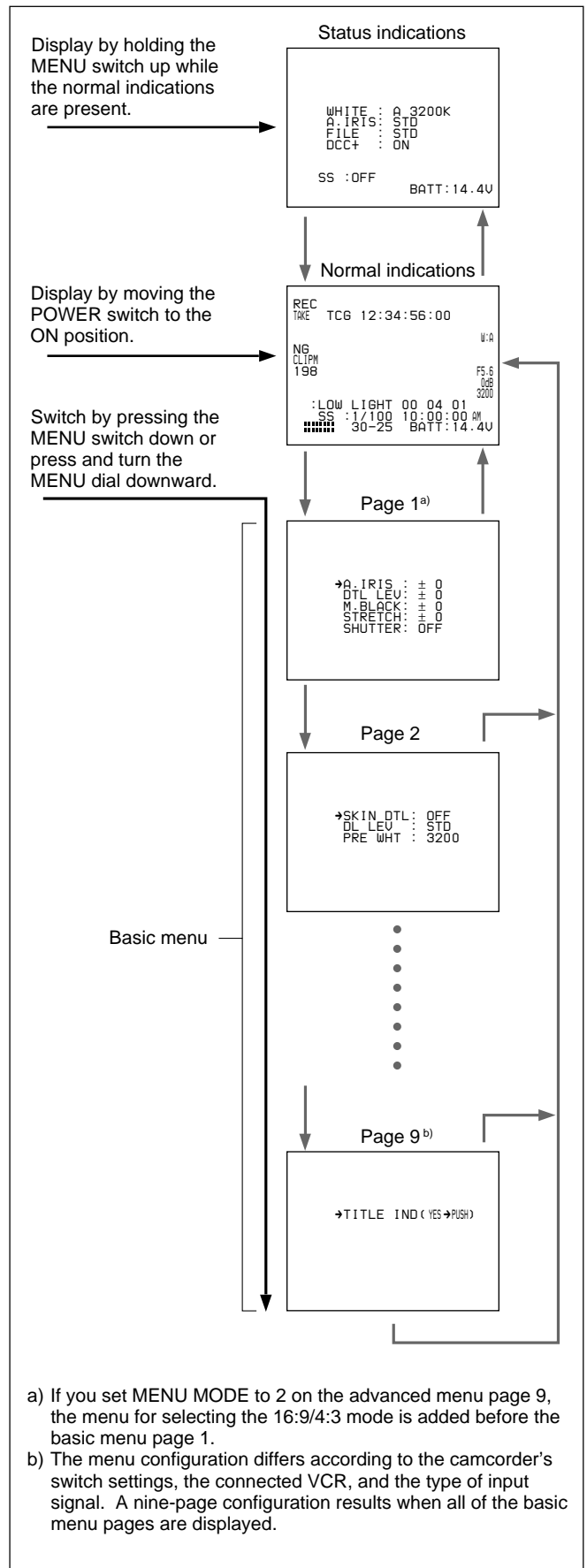

Viewfinder Normal Indications

During normal operation, the following items can be indicated in the viewfinder.

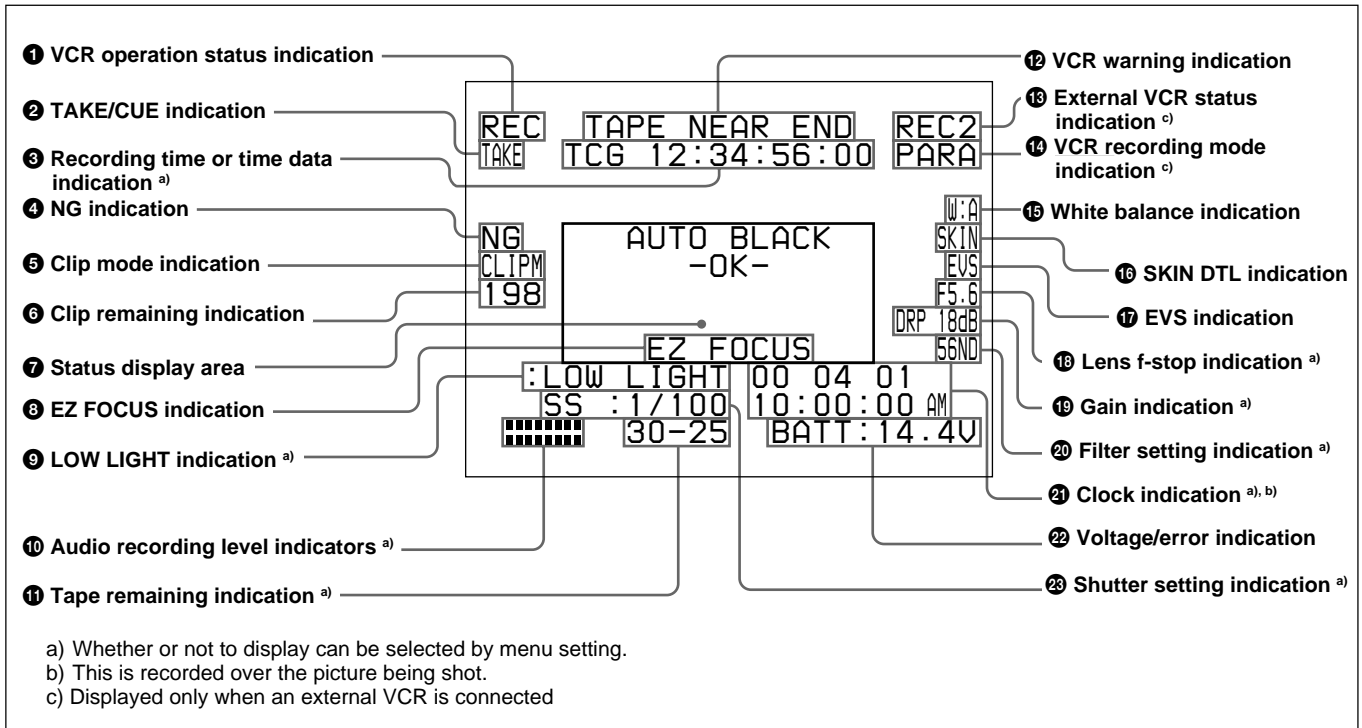

The significance of each of the indications shown in the figure is as follows.

1 VCR operation status indication

This indicates the VCR's current operation status (REC, PLAY, etc.).

2 TAKE/CUE indication

This displays a TAKE or CUE indication when using the ClipLink function for recording.

TAKE: When recording in Mark mode, this indication appears when a Mark IN point is set and disappears when the next Mark OUT point is set.

CUE: When recording in Cue mode, this indication appears for about 1 second when a Cue point is set.

3 Recording time or time data indication

This shows the following values.

- When the REC TIME switch is in the TTL position: The total recording time. (When an external VCR is connected, you can select whether to show the recording time of the internal VCR or of the external VCR using advanced menu page 4. See page 89 for more information.)

- When the REC TIME switch is in the DUR position: The duration of the current recording cut.
- When the REC TIME switch is in the OFF position and the item TC IND in advanced menu page 6 is set to "ON": A time data value depending on the DISPLAY switch settings as shown in the following table.

DISPLAY switch setting	Time data displayed
COUNTER	CNT: Tape transport time
TC	TCG: a time code from the time code generator TCR: a time code from the time code reader
U-BIT	UBG: a user bit value from the time code generator UBR: a user bit value from the time code reader

Time data values appear during playback, fast forward, rewind, or recording review.

4 NG indication

An "NG" (No Good) indication appears if you designate a recorded scene as "NG" when using the ClipLink function for recording.

5 Clip mode indication

A “CLIP M” or “CLIP C” indication appears when you use the ClipLink function for recording.

CLIP M: Indicates shooting in Mark mode

CLIP C: Indicates shooting in Cue mode

6 Clip remaining indication

The number of available clips is displayed when you use the ClipLink function for recording.

7 Status display area

One of the following values or messages is displayed to indicate the camcorder’s current status or its operation status.

- New values when changing camcorder’s settings
- Messages indicating progress or results of adjustments
- The camcorder’s current settings
- SetupLog data recorded to a tape during shooting (*see page 101*)

8 EZ FOCUS indication

This appears when the EZ FOCUS button is pressed, enabling the “easy focus” function.

Note

The status indication is not shown while this indication appears.

9 LOW LIGHT indication

This warning appears if the lighting level is inadequate.

10 Audio recording level indicators

These show the recording levels of audio channels 1 and 2.

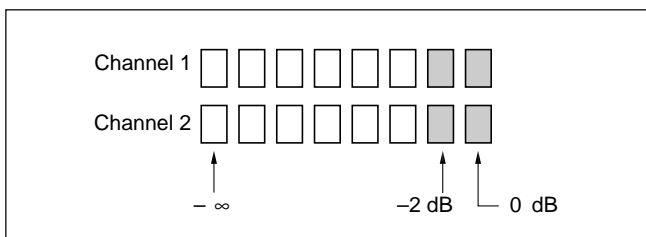

11 Tape remaining indication

This shows the tape remaining as follows.

Indication	Tape remaining
F-30	At least 30 minutes
30-25	25 - 30 minutes
25-20	20 - 25 minutes
20-15	15 - 20 minutes
15-10	10 - 15 minutes
10-5	5 - 10 minutes
5-0	2 - 5 minutes
5-0 (flashing)	0 - 2 minutes

12 VCR warning indication

This shows warning indications about operation or status of the VCR.

Indication	Meaning
NO TAPE	There is no tape loaded.
REC INHIBIT	The tape is in the recording inhibited state.
LOW BATT	The battery is almost exhausted.
BATT END	The battery is exhausted.
TAPE NEAR END	The tape is near the end.
TAPE END	The tape is at the end.
SERVO	The servo lock has been lost.
HUMID	There is condensation.
RF	The video heads are clogged, or there is some other fault in the recording system.
SLACK	The tape is not wound properly.
MP TAPE	An incorrect type of cassette has been loaded. (The cassette is automatically ejected and the indication disappears in about two seconds.)
CLIP DATA ERR	Abnormality of ClipLink log data in the cassette memory data.
AUDIO 48kHz? (4 flashes/s)	At back space editing, you are switching from 32 kHz audio recording mode (4-channel mode) to 48 kHz audio recording mode (2-channel mode).
AUDIO 32kHz? (4 flashes/s)	At back space editing, you are switching from 48 kHz audio recording mode (2-channel mode) to 32 kHz audio recording mode (4-channel mode).
ERROR:91-13F	Failure in loading or saving the cassette memory data.

(Continued)

Viewfinder Normal Indications

Indication	Meaning
CLIP CONT?	Asking whether you will continue shooting in ClipLink mode or not when the cassette contains ClipLink data. (The indication disappears when you press the ClipLink CONTINUE button or start the next shooting without pressing it.)
CLIP NEAR END	At ClipLink shooting, capacity for only 1 to 3 clips remains.
CLIP END	Impossible to record any more clip shots.

Note

If the message appears other than above, contact your Sony dealer.

13 External VCR (connected to the VTR connector (26-pin)) status indication (when an external VCR is connected)

Shows the external VCR operation status.

14 VCR (connected to the VTR connector (26-pin)) recording mode indication (when an external VCR is connected)

Shows recording mode of the internal and external VCRs set by the VTR TRIGGER switch.

Indication	Meaning
PARA	Simultaneous recording of the internal and external VCRs
INT	Recording on the internal VCR
EXT	Recording on the external VCR

15 White balance indication

The following indications appear.

Indication	Meaning
EZ	Operating in EZ mode (The ATW function is selected.)
ATW	The ATW function is selected (The ATW button was pressed and the indication is lit.)
W:A	White balance memory A is selected.
W:B	White balance memory B is selected.
W:P	Preset white balance is selected.
W:M	Manual adjustment is performed remotely.

16 SKIN DTL indication

This appears when the skin detail function is activated (The SKIN DTL switch is set ON.)

17 EVS indication

This appears when the EVS (Enhanced Vertical definition System) function is enabled. (See page 116.)

18 Lens f-stop indication

This shows the f-stop of the lens.

Note

Depending on the lens being used, this indication may differ slightly from the actual f-stop on the lens.

19 Gain indication

This shows the gain value, and the settings of the HYPER GAIN switch (see page 88) and the DPR (Dual Pixel Readout) function as shown in the following table.

Example indication	Meaning
18 dB	Gain setting is 18 dB.
DPR 18 dB	The DPR function is enabled. In this case the DPR function approximately doubles the gain (an increase of 6 dB) over the current gain setting (in this case 18 dB).
HYPER	The HYPER GAIN switch is in the ON position. In this case, the hyper gain function increases the gain about 60 times (36 dB) for 0 dB regardless of the current gain setting. You can also increase the gain about 120 times (42 dB) by switching the menu.

20 Filter setting indication

This shows the setting of the FILTER control.

Indication	Filter setting
3200	1 (3200K)
56ND	2 (5600K + 1/8ND)
5600	3 (5600K)
56ND	4 (5600K + 1/64ND)

21 Clock indication

The clock indication is shown in one of the following ways (according to the CLOCK IND setting of OFF, CAM, or BARS in advanced menu page 8). (See page 91.)

OFF: Not displayed.

CAM: Always displayed.

BARS: Displayed whenever color bars are displayed.

If the clock indication is displayed during recording, it is recorded onto the image.

22 Voltage/error indication

The current voltage is displayed whenever the power supply voltage dips below 11.3 V DC. However, you can also display the current voltage at any time by pressing and holding the MENU switch in the upward position (the display is shown for as long as you hold the switch upward).

An error message is displayed when an abnormality has been detected by the auto diagnostic function (page 85). If there is a voltage drop below 11.3 V DC and an error has been detected, the low voltage indication alternates at one-second intervals with the error indication.

If an error message appears, contact your Sony dealer.

If using an Anton Bauer Intelligent Battery System

The remaining battery capacity is shown as a percentage.

23 Shutter setting indication

When the SHUTTER switch has been set to ON, the basic menu page 1 setting for the item SHUTTER (shutter speed, CLS frequency, EVS) is displayed here.

Status Indications

If you set the MENU switch to STATUS while a menu is being displayed, the camcorder's current setting status will be shown in this display area.

```
WHITE : A 3200K
A.IRIS : STD
FILE   : STD
DCC+   : OFFa)

SS : OFF          BATT : 14.4V
```

a) When both the DCC+ and DynaLatitude functions are set to OFF

Display	Description
WHITE	White balance adjustment method selection (PRE/A/B) and color temperature during auto white balance adjustment
A.IRIS	Iris adjustment method selection (STD/SPOT L/BACK L)
SETUP FILE	Setting of the SETUP switch (page 22)
DCC+ or DL	For DCC+ indication: ON with the OUTPUT/DL/DCC+ switch set to CAM/DCC+ (DCC+ ON), and OFF with the switch set to CAM/DL and DL in advanced menu page 2 (page 88) set to OFF (both DCC+ and DynaLatitude OFF). For DL indication: When setting the OUTPUT/DL/DCC+ switch to DL and DL in advanced menu page 2 to OFF (DynaLatitude OFF), LOW, STD or HIGH is displayed according to DL LEV setting in basic menu page 2 (page 81).

Note

Status indicators will not be displayed during EZ mode.

Viewfinder Basic Menu

To display the basic menu pages, press the MENU switch downward (to ON position) or press the MENU dial while the normal indications are being shown in the viewfinder. The basic menu configuration can include up to nine pages. (The configuration depends on the switch settings.)

Basic Menu Operations

The common operations on all basic menu pages are described below.

To change the page or item

The cursor is moved downward each time you press the MENU switch down. Once the cursor has reached the last item on a page, press down the MENU switch to go to the next page. When the last page is being displayed, pressing down the MENU switch returns the display to the normal indications.

The cursor is moved upward each time you press up the MENU switch. Once the cursor has reached the first item on a page, pressing up the MENU switch returns the display to the normal indications.

The cursor starts blinking when you press the MENU dial. In this state, you can change the page or item by turning the MENU dial.

To change settings

Align the cursor to the desired item using the MENU switch and turn the MENU dial.

You can change settings only with the MENU dial.

Press and turn the MENU dial to align the cursor to the desired item and press the MENU dial.

To reset any item to its shipped settings, press the MENU dial for 2 seconds.

Contents and Settings of Each Menu Page

Each page's contents and settings are described below.

Basic menu page 1

```
→A. IRIS : ± 0
DTL LEV : ± 0
M. BLACK : ± 0
STRETCH : ± 0
SHUTTER : OFF
```

Item	Settings
A. IRIS Sets a base value for auto adjustment of lens iris.	-1.0, -0.5, ±0 (normal value), +0.5, +1.0 Negative adjustment values set a narrower lens iris and positive values set a wider lens iris.
DTL LEV Sets the detail (edge) emphasis.	-99 to ±0 (normal value) to +99 Negative adjustment values soften the image's edges and positive values sharpen them.
M. BLACK Sets the master pedestal level.	-99 to ±0 (normal value) to +99 Negative adjustment values make dark areas of the picture darker and increase the contrast. Positive adjustment values dark areas of the picture lighter and reduce the contrast.
STRETCH Sets black stretch/compress value.	-16 to ±0 (normal value) to +15 This function adjusts the intensity of dark areas of the screen. Negative values make these areas darker (black compress) and positive values make these areas brighter (black stretch).
SHUTTER Sets shutter speed or CLS/EVS setting. (see page 116.)	DSR-500WSL: 1/100 (normal value), 1/250, 1/500, 1/1000, 1/2000, EVS, CLS (60.4 Hz to 200.3 Hz) DSR-500WSPL: 1/60 (normal value), 1/250, 1/500, 1/1000, 1/2000, EVS, CLS (50.3 Hz to 201.4 Hz) This selects either the shutter speed, the scan frequency, or EVS for the clear scan function. When the SHUTTER switch is set to OFF, this item cannot be set.

If you set MENU MODE to 2 on the advanced menu page 9, the menu for selecting the 16:9/4:3 mode is added before the basic menu page 1.

Basic menu page 2

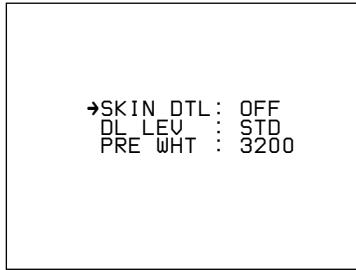

Item	Settings
SKIN DTL Sets the amount of skin detail correction.	0.0 to 0.5 (normal value) to 1.0 Smaller values set a softer skin detail.
DL LEV Sets the DynaLatitude level.	LOW, STD (normal value), HIGH Set the amount of DynaLatitude effects as high level, standard level (STD), or low level.
PRE WHT Sets the color temperature of the preset white balance.	When the filter is 3200 or CROSS: 2200 to 3200 (normal value) to 4300, filter 5600K, 5600K + 1/8ND When the filter is 5600K + 1/64ND: 4600 to 5600 (normal value) to 12000

Basic menu page 3

This is displayed when the SETUP switch has been set to FILE.

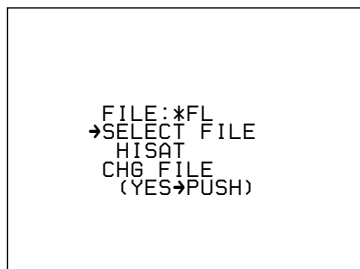

For details of this operation, see "Setup Files" (page 94).

Basic menu page 4

This is displayed when the optional DSBK-501/501P Analog Composite Input Board is fitted to the camcorder.

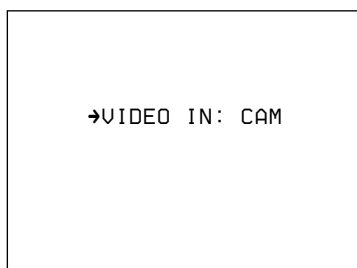

Item	Settings
VIDEO IN Selects the signal to be recorded onto the internal VCR.	CAM (normal value) Records the signal shot by this camcorder. EXT Records the signal input from the GEN LOCK IN/VIDEO IN connector. The image on the viewfinder and the signal output from the MONITOR OUT connector are switched to the external video signal. When inputting the external video signal, "EXT INPUT" blinks on the screen.

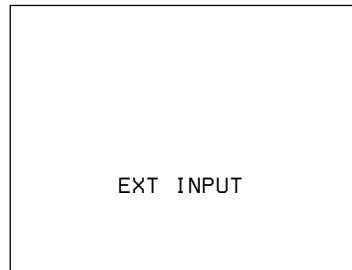

If you set VIDEO IN to EXT and input the external VBS signal from the GEN LOCK IN connector, the image in the viewfinder and the signal output from the MONITOR OUT connector are switched to the external video signal. When inputting the external video signal, "EXT INPUT" always blinks on the screen.

Notes

- When VIDEO IN is set to EXT, the video signals are not output from the S VIDEO OUT connector.
- When VIDEO IN is set to EXT, the basic menu page 5 is not displayed.

Basic menu page 5

This menu is displayed when CAM is selected on the basic menu page 4 and an external sync signal is input to the GEN LOCK IN connector.

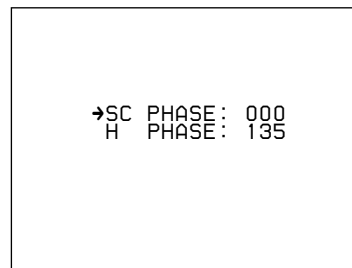

Item	Settings
SC PHASE Sub carrier phase adjustment for when the camcorder is genlocked. ^{a)}	000 to 999
H PHASE Horizontal phase adjustment for when the camcorder is genlocked. ^{a)}	000 to 135 (normal value) to 199

- a) This applies when using an external sync signal to synchronize operation of several camcorders (see page 44).

Viewfinder Basic Menu

Basic menu page 6

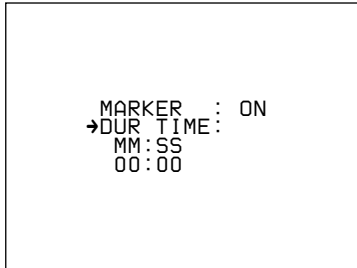

Item	Settings
MARKER Sets marker display ON/OFF.	ON (normal value), OFF Markers are displayed when this setting is ON and is not displayed when it is OFF. When the setting is ON, go to advanced menu page 4 to select the type of marker (see page 89).
DUR TIME Sets the recording time. Setting the recording time before shooting helps you with making scenes of equal duration. When shooting with displaying the recording time of the current cut in the viewfinder (with the REC TIME switch set to DUR), the recording time indication flashes to remind you that the recording time has passed.	00:00 to 59:59 (minute : second) See "Setting the recording time in seconds".

Setting the recording time in seconds

Move the cursor to DUR TIME, then press the MENU dial.

A value of seconds appears.

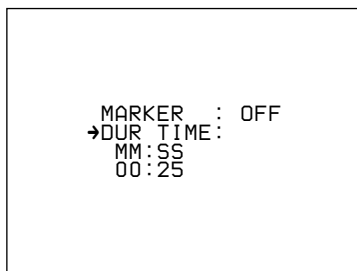

If you turn the MENU dial when "59" is displayed, the number under "MM" increased by one.

Basic menu page 7

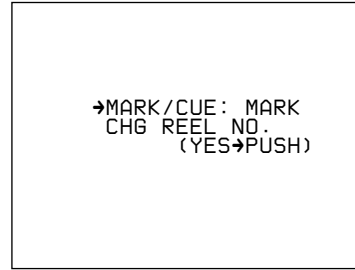

Item	Settings
MARK/CUE Selects Mark mode or Cue mode	MARK (normal value), CUE See "ClipLink Shooting" (page 68).
CHG REEL NO. Sets the cassette name/number	See "To set the cassette name/number" below.

To set the cassette name/number

Note

When using a cassette without cassette memory, you cannot set the cassette name or number.

- 1 Load a cassette.
- 2 Press the MENU switch to move the cursor to CHG REEL NO., then press the MENU dial.

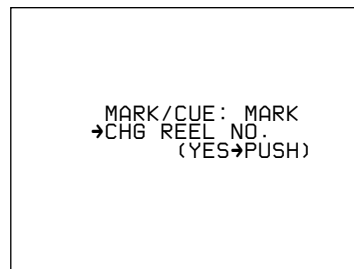

The cursor (→) changes to the text entry arrow (↓) and the current cassette name/number is displayed. ("NO TAPE" is displayed if you neglected to load a cassette.)

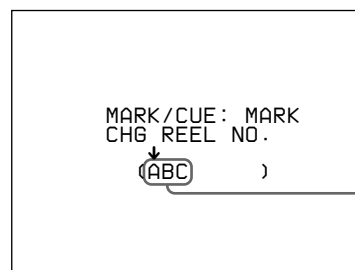

Current cassette name/number

- 3** Turn the MENU dial until the desired character appears, and press it.

The character cycles through the following sequence.

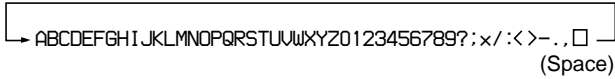

- 4** Turn the MENU dial to move the text entry arrow.
- 5** Return to step **3** and repeat the text entry procedure.
- 6** After completing text entry, move the text entry cursor to the parenthesis position.

The display changes as follows.

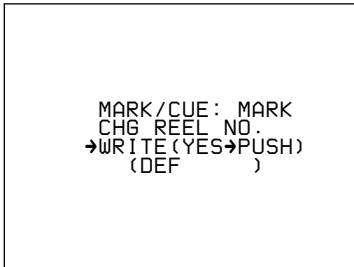

- 7** Check your cassette name/number setting, and press the MENU dial if no more changes are required. (To make changes or to abort the procedure for this setting, return to step **2**.)

This writes the new cassette name/number to the cassette memory, after which the display changes as follows.

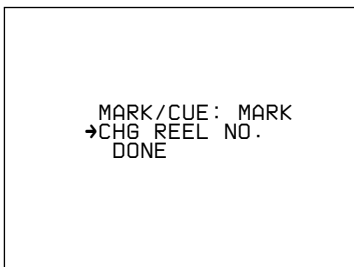

Basic menu pages 8 and 9

You can create a title of up to four lines, each of twelve alphanumeric or punctuation characters, and then save it. It is then possible to record the title over the picture while shooting.

Note

You cannot set the skin detail correction while a title is displayed.

Entering the title (basic menu page 8)

- 1** Press the MENU switch or turn the MENU dial as necessary to display basic menu page 8 (title setting display) in the viewfinder.

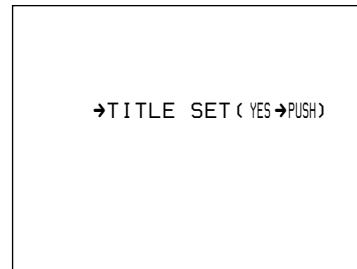

If a title is already present, it appears on this screen.

- 2** Press and turn the MENU dial until the desired character appears.

The character cycles through the following sequence.

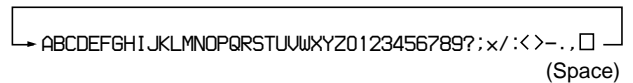

Press the MENU dial when the desired character appears.

(Continued)

Viewfinder Basic Menu

3 Press the MENU dial.

This brings up the cursor on the screen, and switches to cursor transport mode.

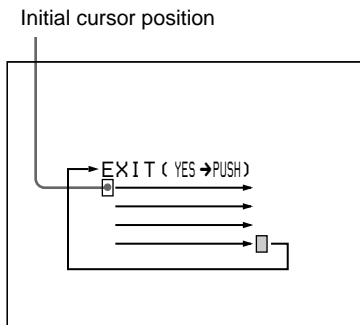

4 Turn the MENU dial to move the cursor to the position where you wish to insert a character.

To reverse the direction, turn the dial in the opposite direction.

5 Repeat steps 2 to 4 until the title is complete.



6 Align the cursor to EXIT and press the MENU dial.

This displays basic menu page 8 again.
The title created is retained, even when you power the camcorder off.

To record a title (basic menu page 9)

1 Access basic menu page 9 (title display).

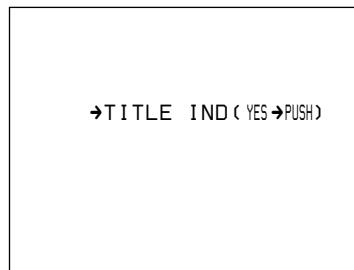

2 Press the MENU dial once.

The title is superimposed to the picture displayed on the viewfinder screen.

3 Start shooting.

4 To stop the title recording, press the MENU switch or MENU dial to clear the title display.

When “CHECK DIAG” is displayed

The “CHECK DIAG” indication appears in the status display area whenever the camcorder’s automatic self diagnostic function detects an abnormality. Access this page and perform error checking. (This page is displayed as basic menu page 1.)

“CHECK DIAG” will also be displayed if there is a problem on the sync signal input to the GEN LOCK IN connector. Input a proper sync signal and then perform error checking.



To perform error checking

Press the MENU dial.

The error checking performs on the digital signal processing (DSP) and memory circuits and the results are displayed.

When no error is detected, “OK” appears.

Example: If an abnormality is detected in the DSP circuit.

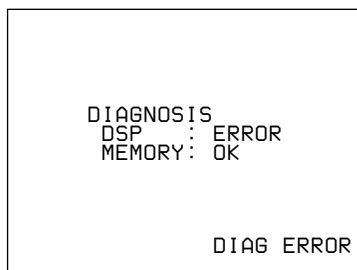

The error message “DIAG ERROR” appears when the normal indications are displayed. If this message appears, contact your Sony dealer.

Viewfinder Advanced Menu

Advanced Menu Operations

See also the figure on next page.

To display the advanced menu

Move the POWER switch to the ON position while holding down the MENU dial.

To change the page

Align the cursor to the page number and press the MENU dial so that the page number is blinking. Turn the dial until the desired page.

To select items in a page

Press the MENU dial to blink the cursor, and press the MENU switch to move the cursor among the menu items. While the cursor is blinking, you can move the cursor by turning the MENU dial.

To change settings

This operation is the same as for the basic menus. **For a description of basic menu operations, see page 80.**

To reinitialize all settings in the advanced menu to their factory defaults

- 1) Align the cursor to ALL RESET and press the MENU dial. (The indication changes to “ALL RESET SURE?”.)
- 2) Press the MENU dial again. (The indication changes to “ALL RESET OK” and reinitialization completes.) To cancel the reinitialization, turn the MENU dial (without pressing).

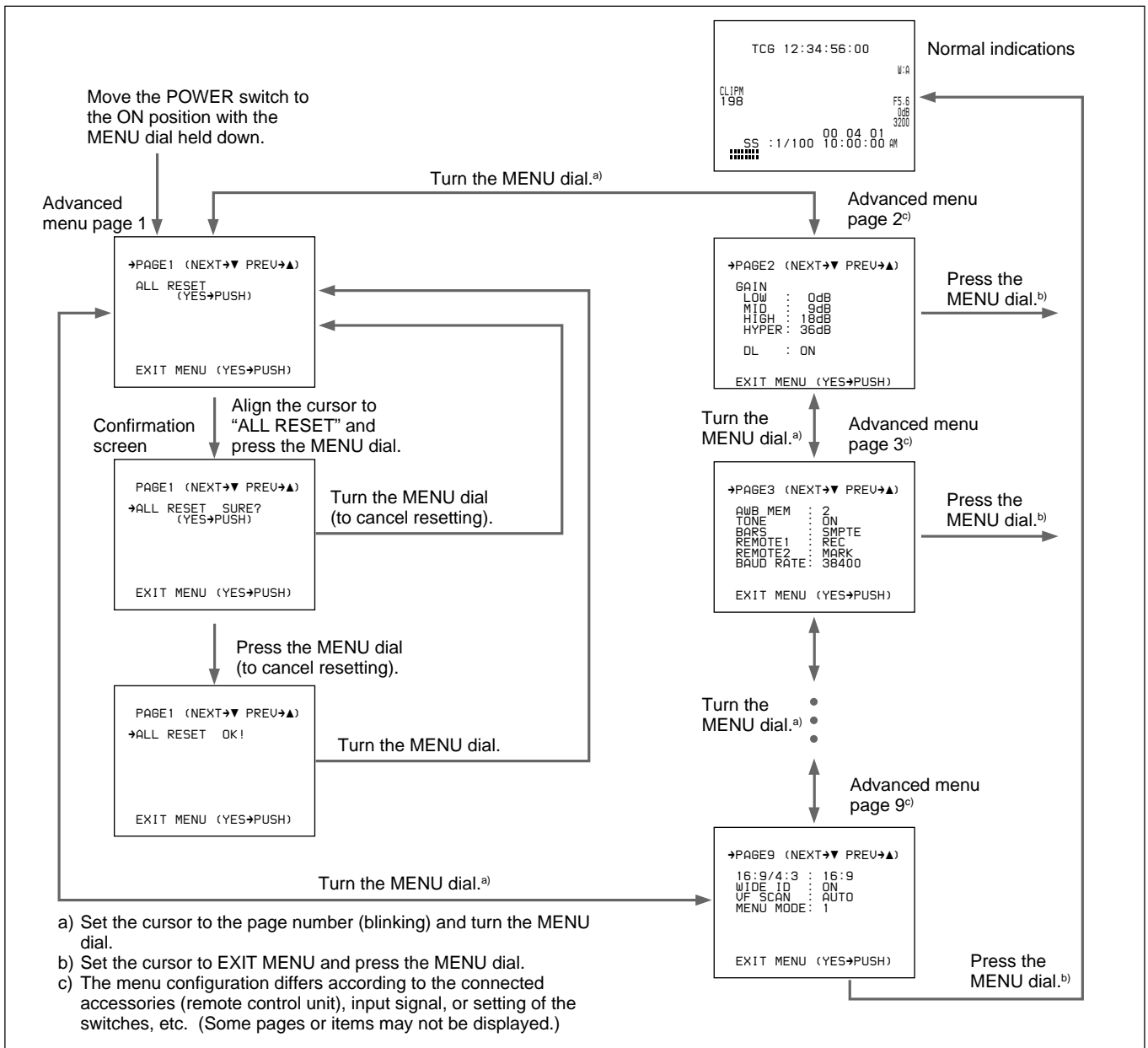

Contents and Settings of Each Menu Page

Each page's contents and settings are described below.

For details of this operation, see "Advanced Menu Operations" (page 86).

Advanced menu page 1

Use this page to return all menu settings to their factory preset values.

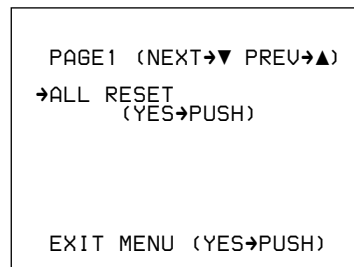

Viewfinder Advanced Menu

Advanced menu page 2

```

PAGE2 (NEXT→▼ PREU→▲)
GAIN
→LOW : 0dB
MID : 9dB
HIGH : 18dB
HYPER: 36dB

DL : ON

EXIT MENU (YES→PUSH)
    
```

Item	Settings
GAIN This sets gain values for the positions of the GAIN switch. The HIGH, MID, and LOW values must be set so that LOW < MID < HIGH.	
LOW Sets the L position.	-3 dB, 0 dB (normal value), 3 dB, 6 dB, 9 dB, 12 dB, 18 dB, 18 dB + DPR, 24 dB
MID Sets the M position.	0 dB, 3 dB, 6 dB, 9 dB (normal value), 12 dB, 18 dB, 18 dB + DPR, 24 dB, 24 dB + DPR
HIGH Sets the H position.	3 dB, 6 dB, 9 dB, 12 dB, 18 dB (normal value), 18 dB + DPR, 24 dB, 24 dB + DPR, HYPER GAIN
HYPER Sets the HYPERS position.	36 dB (normal value), 42 dB
DL Sets DynaLatitude function ON/OFF. This setting is valid only when the OUTPUT/DL/DCC+ switch has been set to CAM/DL.	ON (normal value), OFF When set to ON, the amount of DynaLatitude effects is set in the basic menu page 2 (see page 81). For details on the DynaLatitude function, see page 50.

Advanced menu page 3

```

PAGE3 (NEXT→▼ PREU→▲)
→AWB MEM : 2
TONE : ON
BARS : SMPTE a)
REMOTE1 : REC
REMOTE2 : MARK
BAUD RATE: 38400

EXIT MENU (YES→PUSH)
    
```

a) For DSR-500WSPL: EBU75

Item	Settings
AWB MEM Selects whether or not to make the FILTER control settings (1 to 4) correspond to separate white balance adjustment values stored in memory.	2 (normal value): No correspondence with FILTER control settings. Only two adjustment values (A and B) are stored in memory. 2 × 4FL: Correspondence with FILTER control settings. Each of the four control settings can be used to set A and B adjustment values, for a total of eight settings.
TONE Selects whether or not to output a 1-kHz audio signal with the color bars when the OUTPUT/DL/DCC+ has been set to BARS.	ON (normal value): Outputs audio signal. OFF: Does not output audio signal.
BARS Selects normal width or narrower width for color bars.	SMPTE (normal value for DSR-500WSL): Normal width EBU75 (normal value for DSR-500WSPL): EBU 75% EBU100 (for DSR-500WSPL): EBU 100% SPLIT (for DSR-500WSPL): Not for normal operation SNG: Narrower than normal (used for satellite communications, etc.)
REMOTE1 Sets a function for switch 1 of the RM-LG1 connected to the REMOTE connector 1.	REC (normal value): Specifies recording start/stop. MARK: Specifies a Mark IN/OUT point. CUE: Specifies a Cue point. NG: Specifies NG/OK.
REMOTE2 Sets a function for switch 2 of the RM-LG1 connected to the REMOTE connector 1.	REC: Specifies recording start/stop. MARK (normal value): Specifies a Mark IN/OUT point. CUE: Specifies a Cue point. NG: Specifies NG/OK.
BAUD RATE Sets a baud rate for a computer connected to the REMOTE connector 2 (to be supported in the future version).	9600, 38400 (normal value)

Advanced menu page 4

```

PAGE4 (NEXT→▼ PREU→▲)

MARKER : CENT/90%
LIMITS : OFF
→ZEBRA : 1
ZEBRA1 : 70IREa)
REC TIME: INT
VF TALLY: ×2
LENS SEL: 1

EXIT MENU (YES→PUSH)
    
```

a) For DSR-500WSPL: 70%

Item	Settings
MARKER Selects ON/OFF setting for center marker, size setting (percentage of viewfinder screen area), and display ON/OFF setting.	CENT/90% (normal value): Displays center marker and safety zone marker at 90% size. CENT/80%: Displays center marker and safety zone marker at 80% size. 90%: Displays only safety zone marker at 90% size. 80%: Displays only safety zone marker at 80% size. CENT: Displays only center marker.
LIMITS	OFF (normal value): Displays the image inside the safety zone according to the scan size. 4:3: Displays the image inside the 4:3 safety zone during 16:9 scan size. 14:9: Displays the image inside the 14:9 safety zone during 16:9 scan size.
ZEBRA Selects type of zebra pattern display.	1 (normal value): Displays the zebra pattern over parts having a video level. between 70 and 90 IRE (or 70 and 90%). Use the next item (ZEBRA1) to select the base level. 2: Displays the zebra pattern over parts having video levels of 100 IRE or above (or 100% or above). 1/2: Dual display (both 1 and 2)
ZEBRA1 Sets base level for zebra pattern 1.	70 IRE (normal value) to 90 IRE or 70% (normal value) to 90%: Can be set for each IRE step or 1% step.
REC TIME Selects whether to show the recording time (TTL) of the internal VCR or of the external VCR.	INT (normal value): Recording time of the internal VCR EXT: Recording time of the external VCR connected to the VTR connector (26-pin).
VF TALLY Selects whether or not to use more than one REC/TALLY indicators in the viewfinder (displayed only when the DXF-701WS/701WSCE viewfinder is attached).	×1: Uses only the upper REC/TALLY indicator. ×2 (normal value): Uses two REC/TALLY indicators.

Item	Settings
LENS SEL Select the types of the lens.	1 (normal value), 2,3,4 For details, see "Designating the lens" on page 121.

Advanced menu page 5

```

PAGE6 (NEXT→▼ PREU→▲)

→SS      IND: ALWAYS
LL       IND: ON
IRIS     IND: ON
GAIN     IND: ON
FILTER   IND: ON
WHITE    IND: ON
SKIN     IND: ON

EXIT MENU (YES→PUSH)
    
```

Item	Settings
SS IND^{a)} Selects the mode for showing the shutter setting when displaying the normal indications.	3SEC: Displays shutter setting for three seconds only when the setting has been changed. ALWAYS (normal value): Displays the shutter setting at all times.
LL IND^{a)} Selects whether or not to show the LOW LIGHT indication on the normal indications when inadequate lighting is detected.	ON (normal value): Displays. OFF: Not display.
IRIS IND^{a)} Selects whether or not to show the lens's F-stop value (iris indication) on the normal indications. The F-stop value is always displayed when in EZ mode.	ON (normal value): Displays. OFF: Not display.
GAIN IND^{a)} Selects whether or not to always show the gain setting indication on the normal indications.	ON (normal value): Always displays. OFF: Displays for two seconds only when the setting has been changed.
FILTER IND^{a)} Selects whether or not to always show the FILTER control setting indication on the normal indications. The FILTER control setting indication is always displayed when in EZ mode.	ON (normal value): Always displays. OFF: Displays for two seconds only when the setting has been changed.
WHITE IND^{a)} Selects whether or not to show the setting of the white balance switch.	ON (normal value): Displays. OFF: Not display.
SKIN IND^{a)} Selects whether or not to show the setting for skin detail correction.	ON (normal value): Displays. OFF: Not display.

a) When the viewfinder's DISPLAY switch is set to OFF, indications related to these items are not displayed even when menu settings are set to ON.

Viewfinder Advanced Menu

Advanced menu page 6

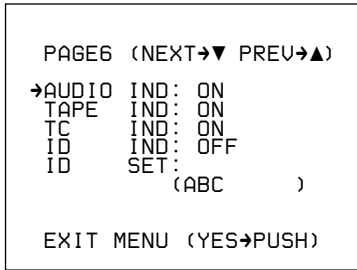

Item	Settings
AUDIO IND^{a)} Selects whether or not to show the audio level indication on the normal indications.	ON (normal value): Displays. OFF: Not display.
TAPE IND^{a)} Selects whether or not to show the remaining tape indication on the normal indications.	ON (normal value): Displays. OFF: Not display.
TC IND^{a)} Selects whether or not to show the time data indication on the normal indications.	ON (normal value): Displays. OFF: Not display.
ID IND^{a)} Selects whether or not to display the camera ID when displaying color bars.	ON (normal value): Displays. OFF: Not display.
ID SET^{a)} Sets the camera ID (up to eight characters, including alphanumeric, symbols, and spaces).	See "To set the camera ID" on below.

a) When the viewfinder's DISPLAY switch is set to OFF, indications related to these items are not displayed even when menu settings are set to ON.

To set the camera ID

1 Press the MENU switch or turn the MENU dial to move the cursor to ID SET.

The cursor (→) changes to the text entry arrow (↓).

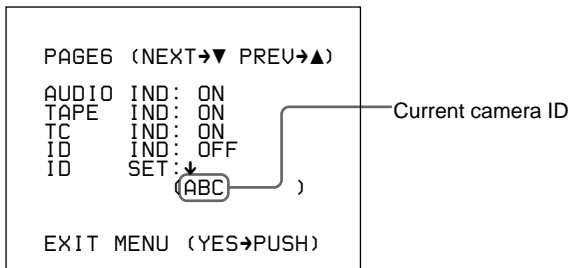

2 Press and turn the MENU dial to move the text entry arrow.

Turn the MENU dial downward to move the cursor to the right, or upward to move it to the left.

3 Press and turn the MENU dial to enter the desired characters.

The displayed character changes as you turn the dial.

4 Return to step 2 and repeat the text entry procedure.

5 When you have finished entering the text, press and turn the MENU dial to move the cursor to the parenthesis position.

This clears the displayed menu and returns to the normal indications.

Advanced menu page 7

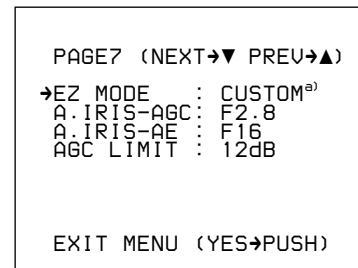

a) At shipping, the EZ MODE is set to STD.

Item	Settings
EZ MODE When the EZ MODE button has been set to EZ mode ON, this selects whether or not to change the settings of other switches and menus to the standard settings. (The EZ mode function cannot be used during remote operation.)	STD (normal value): Changes settings to standard settings. CUSTOM: Changes only some settings to standard settings. <i>For details of the settings when STD or CUSTOM is specified, see "EZ mode settings" on next page.</i>
A.IRIS-AGC Selects auto iris adjustment which sets an F-stop value that can be switched to AGC (displayed only when the EZ MODE is set to CUSTOM).	F1.8, F2.8 (normal value), F4, F5.6
A.IRIS-AE Selects auto iris adjustment which sets an F-stop value that can be switched to AE (displayed only when the EZ MODE is set to CUSTOM).	F5.6, F8, F11, F16 (normal value)
AGC LIMIT Sets an upper limit value for AGC adjustment (displayed only when the EZ MODE is set to CUSTOM).	0, 3, 6, 9, 12 dB (normal value)

EZ mode settings

The following settings are set for the camcorder when EZ mode has been selected.

Item	Settings	
	STD	CUSTOM
Setup file	STD	Selectable
Detail level	±0	Selectable
Master black	±0	Selectable
Black stretch	±0	Selectable
Skin detail	OFF	OFF
Shutter	OFF (AE mode)	OFF (AE mode)
Freeze mix	OFF	OFF
Gain	AGC mode	AGC mode
Hyper gain	OFF	OFF
Iris control method	Automatic	Automatic
Auto iris control mode	STD	STD
Iris override	±0	Selectable
Color bar output	Not output	Not output
AGC upper limit	12dB	Selectable
AGC's F-stop value	F2.8	Selectable
AE's F-stop value	F16	Selectable
ATW	ON	ON
DynaLatitude	OFF	OFF
DCC+	ON	ON
F-stop value indication	ON	ON
Filter indication	ON	ON
Clock indication	OFF	OFF

Advanced menu page 8

```

PAGE8 (NEXT→▼ PREU→▲)
(SET CLOCK W/ VTR)
CLOCK IND: OFF
→DATE MODE: YY MM DD
TIME MODE: 12hours

EXIT MENU (YES→PUSH)

```

Item	Settings
CLOCK IND Selects whether or not to display the date/time on the normal indications.	OFF (normal value): Not display. CAM: Displays. BARS: Displays only when color bars are displayed.
DATE MODE Selects the date display format.	YY MM DD (normal value): Year/month/day MM DD YY : Month/day/year DD MM YY : Day/month/year
TIME MODE Selects whether to display a 12-hour clock (showing A.M. and P.M. hours) or a 24-hour clock.	12hours: 12-hour clock 24hours (normal value): 24-hour clock

Note

Use the VCR menu to set the date and time (*see page 105*).

Viewfinder Advanced Menu

Advanced menu page 9

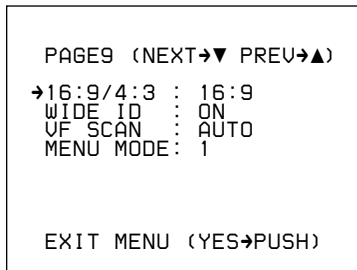

Item	Settings
16:9/4:3 Selects whether to put the camera in 16:9 mode or 4:3 mode.	16:9 (normal value) 4:3^{a)}
WIDE ID Selects whether or not to add a wide aspect ID signal to video output signals in 16:9 mode.	ON (normal value): Adds. OFF: Does not add.
VF SCAN Selects 16:9 or 4:3 as the viewfinder scan size when using the supplied DXF-701WS/701WSCE Viewfinder.	AUTO (normal value): Automatically switch to 16:9 size when the camera is in 16:9 mode, and automatically switch to 4:3 size when the camera is in 4:3 mode. ^{a)} FULL: Regardless of camera's mode (16:9 ^{b)} or 4:3), the viewfinder picture completely fills the display area.
MENU MODE Selects whether or not switch the mode (16:9/4:3) on the basic menu.	1 (normal value): Selects the 16:9 or 4:3 mode only with the advanced menu. 2: Selects the 16:9 or 4:3 mode with both the basic and advanced menus.

- a) Compared to 16:9 mode, the 4:3 mode video appears as if a zoom lens has been adjusted slightly toward the telephoto end (see figure on next page).
- b) When the camera is in 16:9 mode, the viewfinder picture appears stretched vertically (see figure on next page).

Advanced menu pages 10 to 13

These pages are displayed only when the SETUP switch has been to FILE.

For details of this operation, see "Setup Files" (page 94).

Advanced menu pages 14 and 15

These pages are displayed only when the SETUP switch has been to FILE.

For details of this operation, see "Using SetupNavi and SetupLog" (page 99).

Video Output and Viewfinder Picture

The video output and viewfinder picture of this camera vary as shown below according to the settings of the 16:9/4:3 item and the VF SCAN item of the advanced menu page 9.

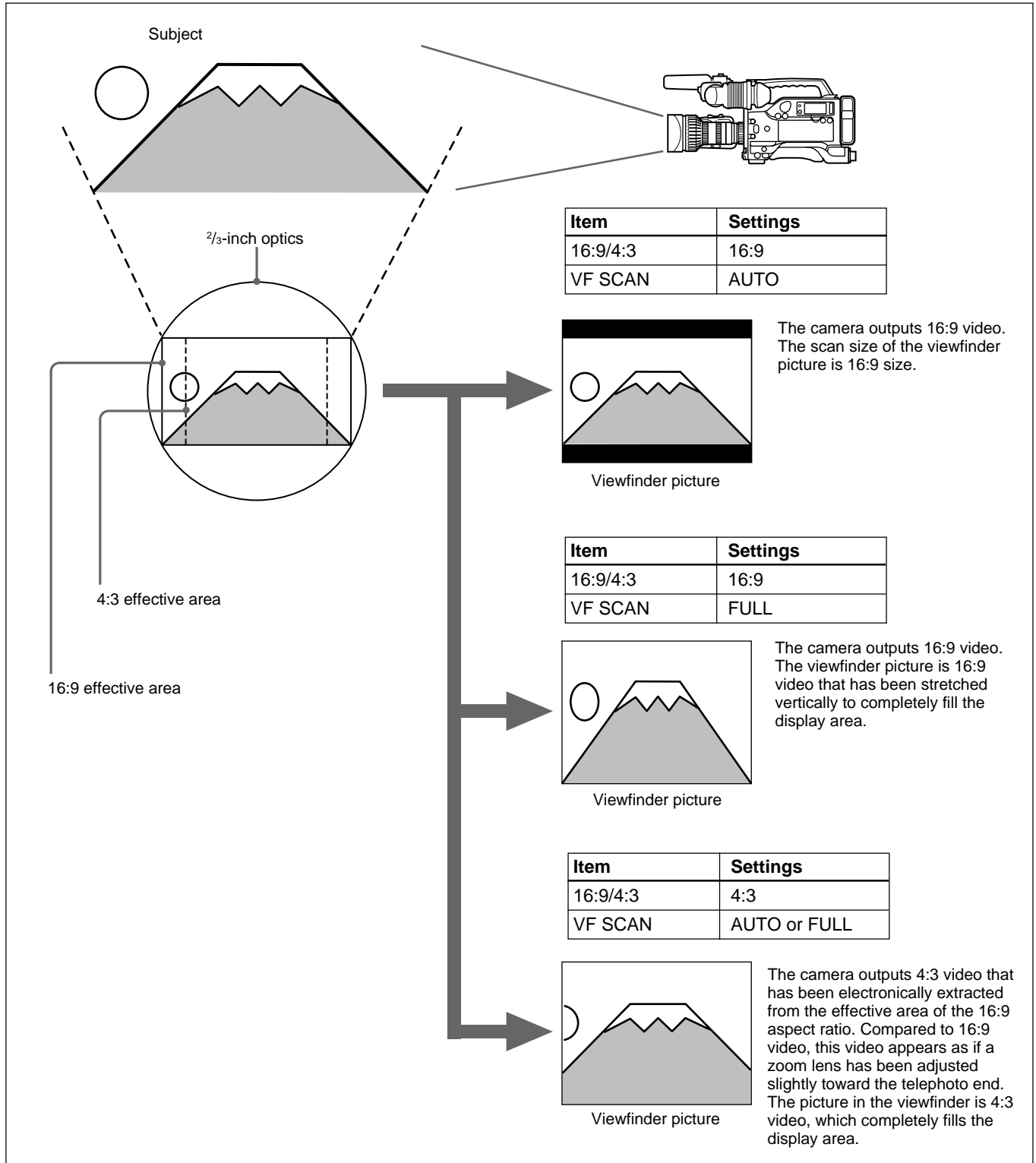

Setup Files

You can use setup files to reproduce a particular configuration of settings. You can also revise the contents of setup files.

There are eight types of setup files, of which five are factory preset setup files and the other three are user files.

Note on using an RM-M7G Remote Control Unit

When an RM-M7G is connected to the camcorder, the setup file function cannot be used.

To make it possible to use this function, power OFF the camcorder after disconnecting the RM-M7G, then power ON the camcorder again.

Calling up a Setup File

This describes how to call up a setup file and use it to replace the current menu settings.

- 1 Set the SETUP switch to FILE.

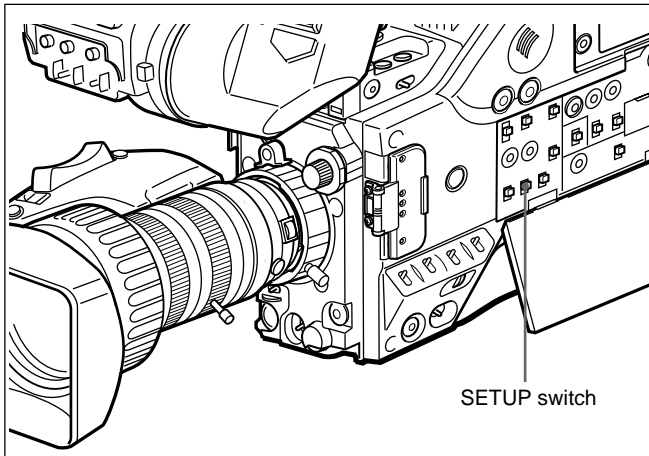

The camcorder is set according to the currently-selected file data.

- 2 Access basic menu page 3.

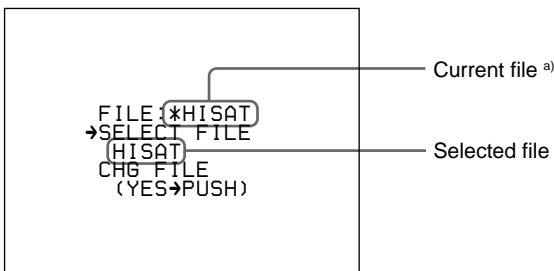

a) An asterisk (*) appears in front of any factory preset file whose contents have been revised at least once.

- 3 Move the cursor to SELECT FILE with the MENU switch and use the MENU dial to select the desired file.



File	Description
STD	Settings for shooting under standard conditions
HISAT	Settings for making pictures vivid
FL	Settings for shooting under fluorescent lighting
FILMLIKE	Settings for making pictures like ones shot by film camera
SVHS/VHS	Settings to optimize camera image for recording and playback characteristics of S-VHS, VHS, or Hi-8 tape
USER1 to USER3	User setup files (set to STD at shipping)

- 4 Move the cursor to CHG FILE and press the MENU dial.

The display changes as shown below and the selected file is called up.

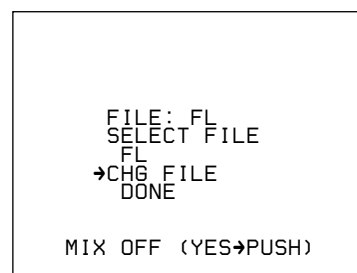

You can also call up these files via a similar operation in advanced menu page 10. In this page, a file recorded onto a tape can also be called up.

For details, see "To call up files recorded onto a tape" (page 95).

To call up files recorded onto a tape

Load the cassette that contains the recorded files.

- 1 Set the SETUP switch to FILE.
- 2 Access advanced menu page 10.

```

→PAGE10 (NEXT→▼ PREV→▲)
FILE RECALL
FILE: *HISAT
SELECT FILE
  HISAT
  CHG FILE
  (YES→PUSH)

EXIT MENU (YES→PUSH)

```

- 3 Move the cursor to SELECT FILE with the MENU switch and move the MENU dial to select TAPE.

```

PAGE10 (NEXT→▼ PREV→▲)
FILE RECALL
FILE: *HISAT
→SELECT FILE
  TAPE
  CHG FILE
  (YES→PUSH)

EXIT MENU (YES→PUSH)

```

- 4 Move the cursor to CHG FILE and press the MENU dial.

The screen appears as shown below.

```

PAGE10 (NEXT→▼ PREV→▲)
FILE RECALL
FILE: *HISAT
SELECT FILE
  TAPE
→READY TAPE
  (YES→PUSH)

EXIT MENU (YES→PUSH)

```

- 5 Press the MENU dial to call up the file. To abort the call up operation, press the MENU switch (the display returns to the one shown in step 3).

During the call up operation, the following display appears.

```

PAGE10 (NEXT→▼ PREV→▲)
FILE RECALL
FILE: *HISAT
SELECT FILE
  TAPE

SETUP FILE: USER2
EXIT MENU (YES→PUSH)

```

When the call up operation ends, the display changes as shown below.

```

PAGE10 (NEXT→▼ PREV→▲)
FILE RECALL
FILE: (USER2)
SELECT FILE
  USER2
→CHG FILE
  DONE

EXIT MENU (YES→PUSH)

```

Name of file recorded onto tape

The settings of the camcorder are now replaced by the settings in the called file.

Changing File Settings

When using advanced menu page 11 or 12, you can change the settings about picture quality in setup files. (In basic menu page 1, a part of items are changeable.) The changes are accepted only until another file is called up, after which the original settings are restored. If you save the changes, store the modified file as one of the user files or record it in a cassette. (See the following section “Saving File Settings”.)

- 1 Perform the steps described in “To call up files recorded onto a tape” on page 95 to call up the selected file.
- 2 Access advanced menu page 11 or 12.

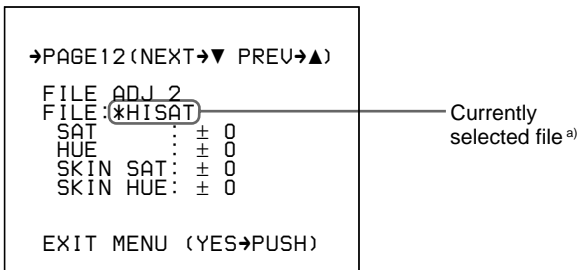
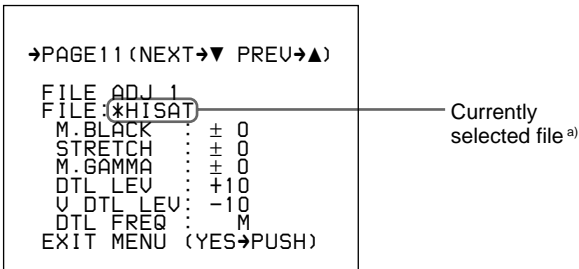

- a) An asterisk (*) appears in front of any factory preset file whose contents have been revised at least once.

- 3 Make the desired changes.

Page 11

Item	Settings
M.BLACK, STRETCH and DTL LEV	See “Basic menu page 1” (page 80).
M.GAMMA Adjusts the gamma curve.	-99 to ±0 (normal value) to +99
V DTL LEV Adjusts the vertical detail.	-99 to ±0 (normal value) to +99
DTL FREQ Adjusts the central frequency of the detail.	LL, L, M (normal value), H, HH

Page 12

Item	Settings
SAT Adjusts the saturation of the image.	-99 to ±0 (normal value) to +99 Negative adjustment values decrease the saturation and positive adjustment values increase the saturation.
HUE Adjusts the hue of the image.	-99 to ±0 (normal value) to +99
SKIN SAT Adjusts the saturation in the specified area of the image.	-99 to ±0 (normal value) to +99 Negative adjustment values decrease the saturation and positive adjustment values increase the saturation.
SKIN HUE Adjusts the hue in the specified area of the image.	-99 to ±0 (normal value) to +99

Saving File Settings

Files whose settings have been changed for certain shooting conditions can be saved as a user file or onto a tape.

For details, see “To save setup files to a tape” (page 97).

- 1 Set the SETUP switch to FILE.

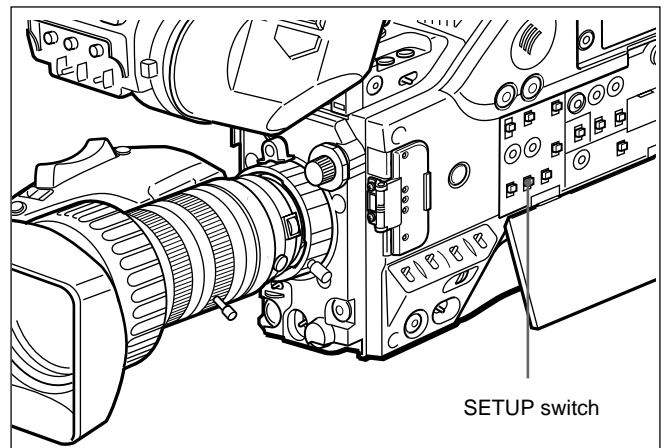

- 2 Call up a setup file whose settings approximate the desired shooting conditions and then change some of the settings.

For details of this operation, see “Calling up a Setup File” (page 94), “Changing File Settings” above, “Basic Menu Operations” (pages 80 to 84), and “Advanced Menu Operations” (pages 86 to 92).

3 Access advanced menu page 13.

```

→PAGE13 (NEXT→▼ PREU→▲)
FILE STORE
FILE:*HISAT
DESTINATION FILE
USER1
STORE FILE
(YES→PUSH)

EXIT MENU (YES→PUSH)

```

Currently selected file^{a)}

a) An asterisk (*) appears in front of any factory preset file whose contents have been revised at least once.

```

PAGE13 (NEXT→▼ PREU→▲)
FILE STORE
FILE:*HISAT
DESTINATION FILE
USER1
→STORE FILE
DONE

EXIT MENU (YES→PUSH)

```

4 Move the cursor to DESTINATION FILE with the MENU switch and turn the MENU dial to select USER1, USER2, or USER3.

```

PAGE13 (NEXT→▼ PREU→▲)
FILE STORE
FILE:*HISAT
→DESTINATION FILE
(USER1)
STORE FILE SURE?
(YES→PUSH)

EXIT MENU (YES→PUSH)

```

File in which current settings are to be stored

5 Move the cursor to STORE FILE? with the MENU switch and press the MENU dial.

The display changes as shown below.

```

PAGE13 (NEXT→▼ PREU→▲)
FILE STORE
FILE:*HISAT
DESTINATION FILE
USER1
→STORE FILE SURE?
(YES→PUSH)

EXIT MENU (YES→PUSH)

```

6 Press the MENU dial to store the file. To abort the save operation, press the MENU switch (the display returns to the one shown at step 4).

When the save operation is finished, the display changes as shown below.

To save setup files to a tape

Load the tape onto which the file will be recorded.

1 Perform steps 1 to 4 of “Saving File Settings” and select TAPE as the file saving destination.

```

PAGE13 (NEXT→▼ PREU→▲)
FILE STORE
FILE:*HISAT
→DESTINATION FILE
TAPE
STORE FILE
(YES→PUSH)

EXIT MENU (YES→PUSH)

```

2 Move the cursor to STORE FILE? with the MENU switch and press the MENU dial.

The display changes as shown below.

```

PAGE13 (NEXT→▼ PREU→▲)
FILE STORE
FILE:*HISAT
DESTINATION FILE
TAPE
→READY TAPE
(YES→PUSH)

EXIT MENU (YES→PUSH)

```

(Continued)

Setup Files

- 3** Press the MENU dial to store the file. To abort the save operation, press the MENU switch (the screen returns to the screen shown in step **2**).

The tape automatically rewinds and recording starts.

The display changes as shown below. (“CAN NOT WRITE” appears on the screen if no tape is loaded or if the loaded tape is write-protected.)

```
PAGE13 (NEXT→▼ PREV→▲)
FILE STORE
FILE:*HISAT
DESTINATION FILE
TAPE

SETUP FILE:*HISAT
EXIT MENU (YES→PUSH)
```

After the settings are stored, the following display appears.

```
PAGE13 (NEXT→▼ PREV→▲)
FILE STORE
FILE:*HISAT
DESTINATION FILE
TAPE
→STORE FILE
DONE

EXIT MENU (YES→PUSH)
```

Using SetupNavi and SetupLog

The SetupNavi function records a setting of the setup menu and setup files onto a tape, so that the same settings can be called up and used again or copied to another camera.

The SetupLog function records a camera setting every few seconds at shooting and displays the recorded data in the viewfinder during playback.

Note on using an RCP-TX7/RM-M7G Remote Control Unit

When an RCP-TX7/RM-M7G is connected to the camcorder, you can use neither the SetupNavi function nor the SetupLog function.

To make it possible to use these functions, power OFF the camcorder after disconnecting the RCP-TX7/RM-M7G, then power ON the camcorder again.

Setting Up the Camera Using Data Recorded on Tape

The procedure to replace camera's menu settings with settings recorded onto video tape is described here.

- 1 Insert the cassette onto which the data was recorded. Set the SETUP switch to FILE, then set the POWER switch to ON while holding down the MENU dial.

Advanced menu page 1 appears.

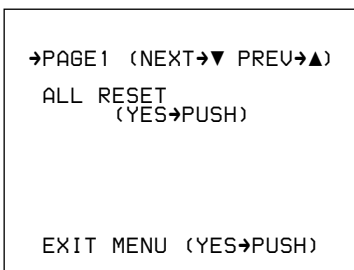

- 2 Turn the MENU dial until advanced menu page 14 appears.

For details of menu operation, see "Advanced Menu Operations" (page 86).

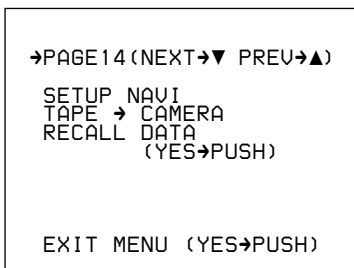

"NO TAPE" is displayed if you neglected to load a cassette.

- 3 Move the cursor to RECALL DATA with the MENU switch to call up the data recorded on the tape. (Press the MENU switch to cancel.)

The tape is rewound and playback starts. The display changes as follows and the call up operation begins.

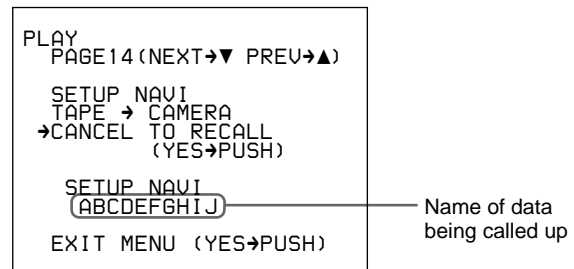

To abort the call up operation while in progress
Press the MENU dial.

After the data has been read, the following display appears.

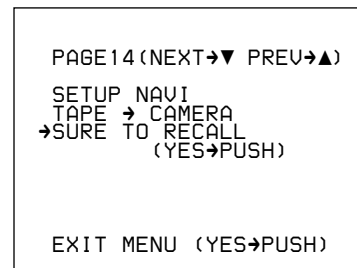

- 4 Press the MENU dial.

The previous menu settings are overwritten by the data recorded on the tape.

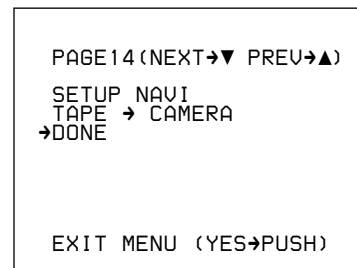

- 5 Change the menu settings if necessary.

Recording the Menu Settings Onto a Tape

1 Load the tape onto which the settings are to be recorded. Turn the camcorder power on.

2 Make your basic menu settings.

For details of this operation, see “Basic Menu Operations” (page 80).

3 Again, set the POWER switch to ON while holding down the MENU dial.

4 Make your advanced menu settings.

For details of this operation, see “Advanced Menu Operations” (page 86).

5 Access advanced menu page 15 and move the cursor to STORE DATA.

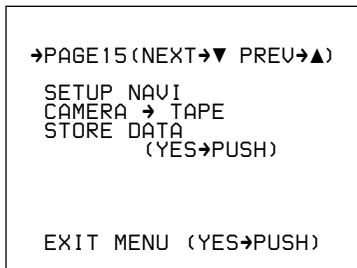

“NO TAPE” appears if you neglected to load a cassette.

6 Press the MENU dial.

The following display appears.

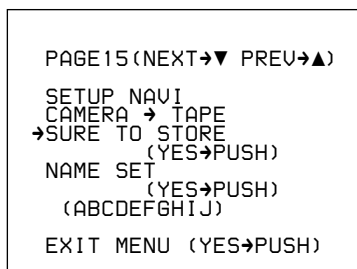

7 Set the cursor to “NAME SET” and press the MENU dial. (Press the MENU switch to cancel.)

The cursor (→) changes to the text entry cursor (↓).

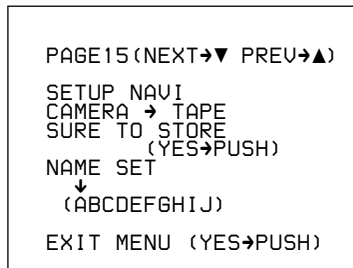

8 Enter a name for the data.

Moving the text entry cursor: Press the MENU switch down to move the cursor to the right, and press the MENU switch up to move the cursor to the left.

Selecting the character: Turn the MENU dial until the desired character appears.

9 After completing text entry, move the cursor to the parenthesis position.

The display changes as follows.

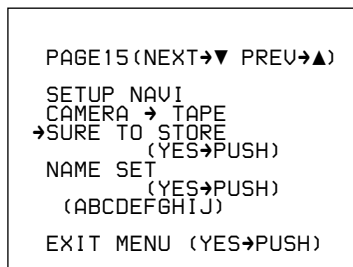

10 Move the cursor to “SURE TO STORE?” and press the MENU dial (press the MENU switch to cancel).

The tape is rewound and the recording starts. The display changes as follows and the data recording begins.

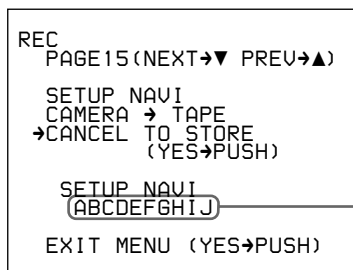

Name of data being recorded

To abort the data recording while in progress
Press the MENU dial.

After the data has been recorded, the following display appears.

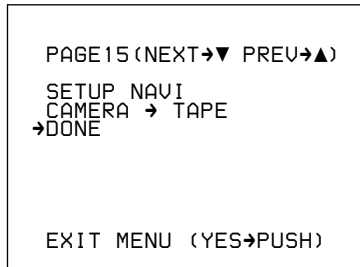

Notes

- It takes about three and a half minutes to record the data.
- The former setupnavi data or the recorded contents of the tape are overwritten.

Viewing SetupLog Data

The SetupLog function records camcorder settings every few seconds at shooting and displays the recorded data in the viewfinder during playback.

Note

Setup log data is not displayed when external analog video signals are being recorded.

To view the SetupLog Data, perform the following procedure.

- 1 Turn the power on and load the tape that contains the recording to be viewed.
- 2 Play back the tape.
For details of playback operation, see page 61.
- 3 Press the MENU switch upward (to STATUS position).

The display changes to page 1 of the status display.

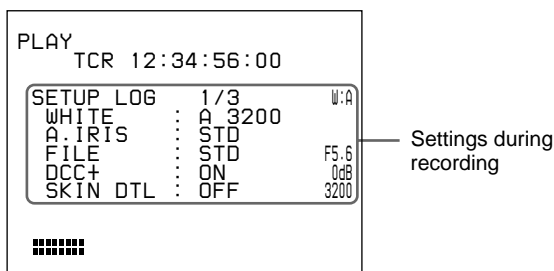

Each time you press upward the MENU switch, the status display cycles through the status pages and playback display in the order: page 2, page 3, the playback display (containing the current settings), and page 1.

Status display (page 2)

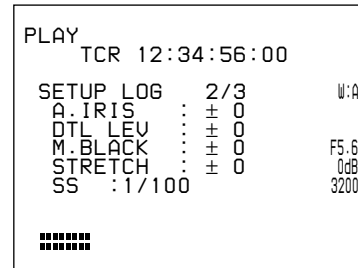

Status display (page 3)

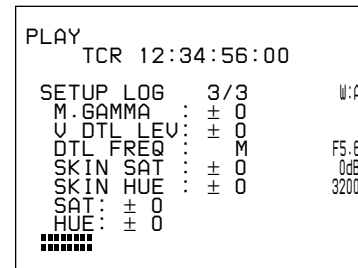

Notes

- SetupLog data is not recorded while SetupNavi data or a setup file is being recorded onto the portion of a tape. (If you play back that portion of a tape containing SetupNavi data or a setup file, the data displayed in the setup display is not the SetupLog data of the playback picture.)
- In the following cases, changed settings that were not recorded may appear as blank settings.
 - SetupLog data is overwritten at intervals of a few seconds during recording. If the settings are changed frequently for certain items, it may not always be recorded in time.
 - If the recording time is very short, recording may be ended before all of the data has been overwritten.

Setting on the VCR Section — VCR Menu

You can use the VCR menu for settings on the VCR section.

Operation	Menu No.	Reference
Real time clock and calendar settings	101	Page 105
Cumulative hour counts: <ul style="list-style-type: none">• Head drum operating hours• Tape transport hours• Operating (power-on) hours	201	Page 105
Frame mode selection for time code (DSR-500WSL only)	204	Page 105
Battery capacity indication selection	206	Page 106
Standby-on period setting	207	Page 106
Use auto-check function	210	Page 107
Selection of ClipLink function	211	Page 109
Audio recording mode selection	212	Page 109
Audio reference level selection	213	Page 110
Fade-in/fade-out setting for the audio recording start and stop points	214	Page 110
Use setup add (DSR-500WSL only)	220	Page 111
Use setup remove (DSR-500WSL only)	221	Page 111

If you want to change the following setting, consult your Sony dealer.

- Outputs the playback time code signals from the TC OUT connector during playback.

VCR Menu Operation

Basic Operation

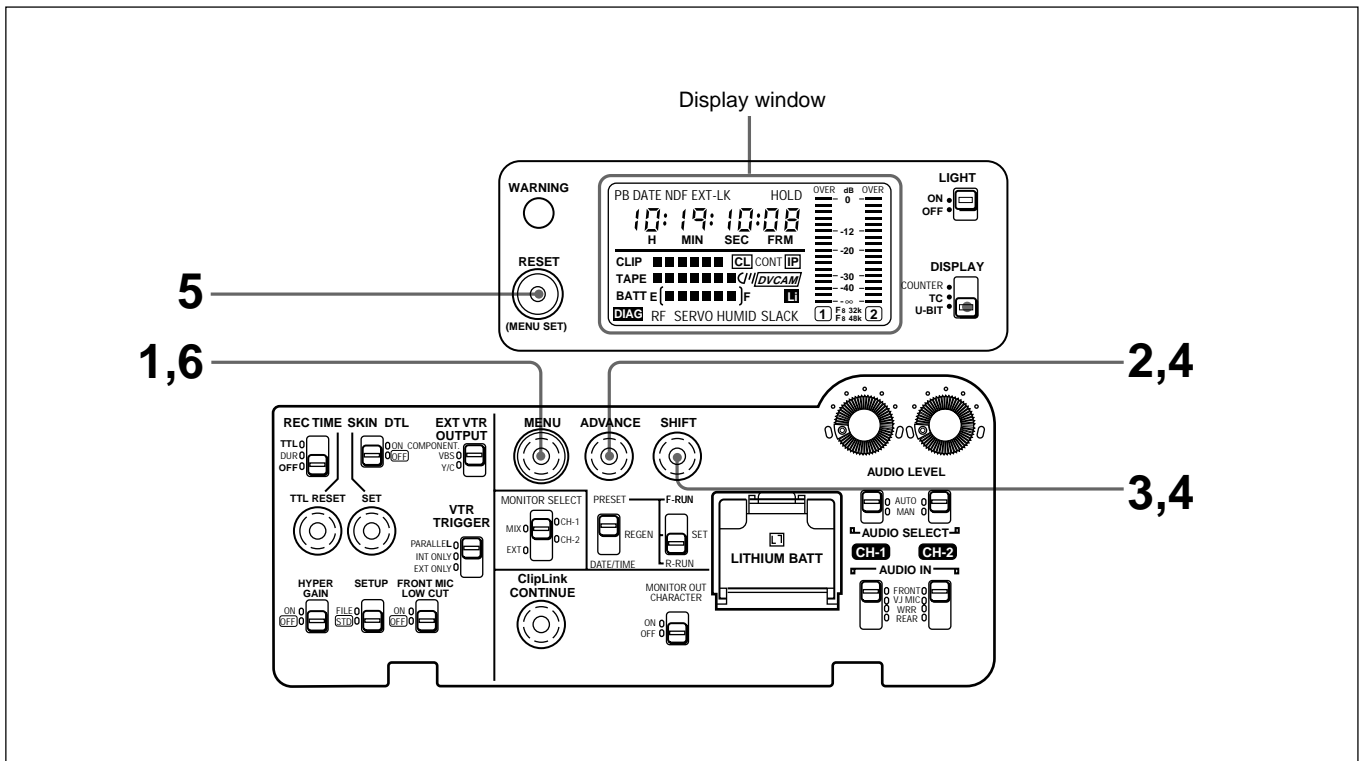

1 Press the MENU button.

“DIAG” appears in the display window and the time data display in the display window switches to the menu display.

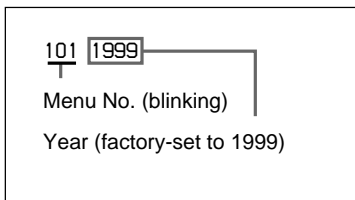

2 Press the ADVANCE button repeatedly until the desired menu appears.

3 Press the SHIFT button.

This shows the current settings for the menu selected by step 2.

The setting can be changed for the digit that is blinking.

To exit from changing settings

Press the MENU button to close the menu.

4 Change the settings.

Operation	Step
Select digit to be changed	Press the SHIFT button.
Change the value	Press the ADVANCE button.

5 Press the RESET/(MENU SET) button.

This records the new setting and returns to a blinking display of the menu number.

6 Press the MENU button.

This returns the display window to the display shown before the VCR menu.

Menu 101 Setting the Real Time Clock and Calendar

- 1 Display menu 101 and press the SHIFT button.

The current calendar setting appears in the setting mode format (yyyymmdd).

Example: October 8, 2000

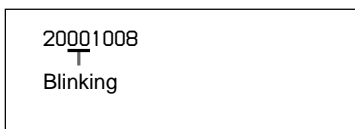

Note

The first two digits of the year setting cannot be directly changed.

- 2 Use the SHIFT and ADVANCE buttons to set the desired date.

If there are no more new settings to be made, go directly to step 5.

- 3 Press the SHIFT button while the date display is blinking (Example: 20001008).

The current time (real time clock) setting is displayed.

Example: 10:15:05 PM

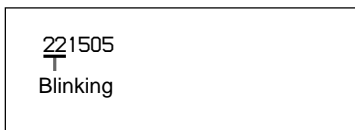

- 4 Use the SHIFT and ADVANCE buttons to set the current time.
- 5 Press the RESET/(MENU SET) button.

This starts the clock advance operation.
- 6 Press the MENU button.

This returns the display window to the display shown before the VCR menu.

The date set can be displayed in the time value indication (*see page 62*) in the following way.

On the DSR-500WSL: Displayed in mmddyyyy format (Example: 10081999)

On the DSR-500WSPL: Displayed in ddmmyyyy format (Example: 08101999)

Menu 201 Checking the Total Operating (Power-On) Hours

- 1 Display menu 201 and press the SHIFT button.

Pressing the SHIFT button cycles through the following display items.

Indication	Example
Head drum operating hours	A 0492Hr
Tape transport hours	b 0480Hr
Total operating hours	C 0835Hr
Menu number	201 0492

- 2 Check the indication, then press the RESET/(MENU SET) button, and then the MENU button.

This returns the display window to the display shown before the VCR menu.

Menu 204 Selecting Frame Mode (DF/NDF) for Time Code (for DSR-500WSL Only)

Select frame modes when setting the time code.

Drop-frame mode (factory setting): When adjusting the discrepancy between time code value and real time

Non-drop-frame mode: When you need not adjust the discrepancy between time code value and real time

For details of time code settings, see page 64.

(Continued)

VCR Menu Operation

1 Display menu 204.

The menu number and the current frame mode setting are shown.

Example: dF (drop-frame mode)

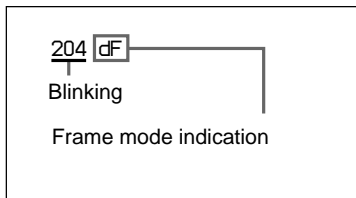

If the setting does not need to be changed, press the MENU button to close the menu.

2 Press the SHIFT button to make the frame mode start blinking, then press the ADVANCE button.

This switches the frame mode display as shown below.

Example: ndF (non-drop-frame mode)

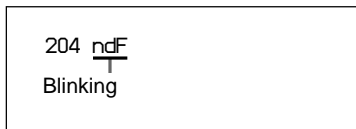

3 Press the RESET/(MENU SET) button and then the MENU button.

The settings are recorded and the display window returns to the display shown before the VCR menu.

Menu 206 Selecting Battery Capacity Indication

This selects the indication type of battery capacity.

1 Display menu 206.

The selected menu number is displayed, along with the name of the currently selected battery.

Example: nI (Indication for the NP-1B/BP-90A)

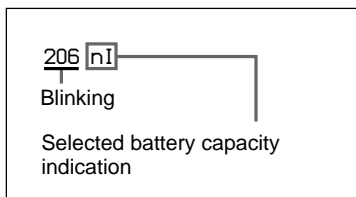

If the setting does not need to be changed, press the MENU button to close the menu.

2 Press the SHIFT button until the desired battery name is displayed, then press the ADVANCE button.

Pressing the ADVANCE button cycles through the following indications.

nI → LI → Antn → Auto

Indication	Meaning
Auto (factory setting)	Automatic detection of battery type.
nI	Indication for NP-1B/BP-90A battery is selected.
LI	Indication for BP-L40/L40A/L60/L60A/L90/L90A battery is selected.
Antn	Indication for Anton Bauer Magnum battery is selected ^{a)} .

a) To use the Anton Bauer Magnum Battery System, a special battery mount developed by Anton Bauer Corporation is required.

For details, contact an Anton Bauer dealer or your Sony dealer.

3 Press the RESET/(MENU SET) button and then the MENU button.

The settings are recorded and the display window returns to the display shown before the VCR menu.

Menu 207 Setting Standby-On Period

At recording pause state or playback pause state, the camcorder waits for a certain standby-on period and then automatically switches to standby-off mode. This standby-on period can be set in advance.

1 Display menu 207.

The selected menu number is displayed, along with the current standby-on period setting (in minutes).

Example: 8 minutes

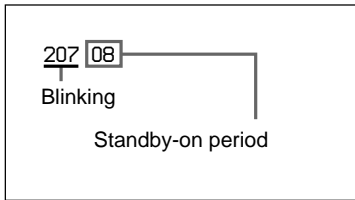

If the setting does not need to be changed, press the MENU button to close the menu.

- 2 Press the SHIFT button until the standby-on period starts blinking, then press the ADVANCE button.

Each press of the ADVANCE button changes the setting as follows.

08 (factory setting) → 01 → 03 → 05

- 3 Press the RESET/(MENU SET) button and then the MENU button.

The settings are recorded and the display window returns to the display shown before the VCR menu.

Menu 210 Using Auto-Check Function

On the DSR-500WSL/500WSPL, the internal check can be automatically performed using the auto-check function. Meanwhile, a test recording and playback are also performed for about one minute.

Before shooting, it is desirable to perform auto-check and make sure for problems in VCR's internal operations through the result of the internal check displayed in the display window and the video and audio recording qualities.

Preparations for testing

Make preparations as shown in the table below.

Preparation	Refer to
Connect a monitor to the MONITOR OUT or S VIDEO OUT connector	Page 25
Connect an earphone or headphones to the EARPHONE connector	Page 15
Prepare a cassette for test recording/playback	Page 53

To perform the auto-check

- 1 Display menu 210.

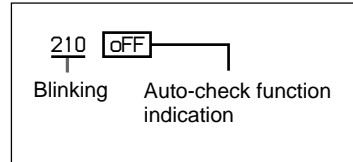

- 2 Press the SHIFT button to make the auto-check function indication (oFF) start blinking, then press the ADVANCE button to change the indication to "on".

To cancel the auto-check function, press the MENU button to close the menu.

- 3 Press the RESET/(MENU SET) button.

This changes the display and opens the cassette holder. If there is a cassette in the holder, it is ejected (except during recording).

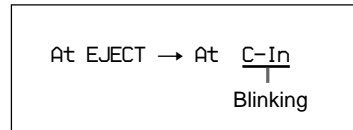

- 4 Insert the cassette and close the cassette holder.

The display changes to the following, and the tape is loaded.

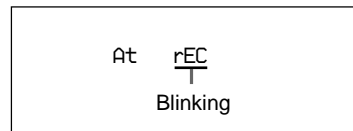

- 5 Use the tape transport buttons to change the tape position for test recording if necessary, or advance to step 6.

(Continued)

VCR Menu Operation

6 Press the VTR button on the camcorder or lens.

Test recording starts.

The display changes as shown below during recording. (The hyphen following "At" moves to right.)

At - → At - →... → At -

After about 1 minute, the tape is rewound to the recording start position and playback starts. The following is displayed during playback.

At PLAY

7 Check the recording quality of the playback video in the viewfinder or on the monitor screen. Check the recording quality of the playback audio from the speaker, earphone, or headphones.

If the recording quality is poor

There may be some kind of problem whether or not it is detected by the internal check. Refer to the section "Troubleshooting" (page 129) and repeat the test. If the recording quality remains poor, contact your Sony dealer.

When playback ends, the internal check result is displayed and the camcorder enters recording pause mode.

8 After confirming the result (see the next section "Confirming the result"), press the MENU button.

The display window returns to the display shown before the VCR menu.

Confirming the result

The result of the internal check is displayed in code as shown in the table below. When a problem is indicated, follow the instructions to check the camcorder and cassette. If no errors can be found, contact your Sony dealer.

Also, be sure to check the quality of the playback video and audio (see step 7).

Display	Diagnostic result
At good	VCR's internal operations are normal. If the video and audio recording qualities are normal, the unit is ready for use.
At ng-01	There may be a problem in the VCR or the cassette. Contact your Sony dealer.
At ng-02	There may be a problem in VCR's internal operations or data loading from the tape. Clean the video heads using the DVM-12CL Cleaning Cassette (see page 126) and repeat the auto-check. If the result is the same, contact your Sony dealer.
At ng-03	There may be a problem in the link between the camera and VCR sections. If not, correct the error and repeat the auto-check. If the result is the same, contact your Sony dealer.
At ng-04	Check whether the REC/SAVE switch is set to SAVE. If so, repeat the auto-check with setting the switch to REC or using another cassette whose REC/SAVE switch is set to REC. If the result is the same, contact your Sony dealer.
At ng-05	Check whether a cassette is inserted. If not, insert a cassette and repeat the auto-check. If the result is the same, contact your Sony dealer.
o-HAUL	If the video and audio recording qualities are normal, the unit is ready for use. However, the unit requires service. It is desirable to consult your Sony dealer.
At Abort	The test recording or playback and internal check have aborted (when a tape transport button was pressed during recording or playback or when the tape ended). To resume the auto-check, press the MENU button to close the menu and perform the procedure described in the previous section "To perform the auto-check".

Menu 211 Selecting ClipLink Function

This setting must be made when not using the ClipLink function.

For details of the ClipLink function, see “ClipLink Shooting” (page 68).

- 1 Display menu 211.

The ClipLink function is factory-set to on.

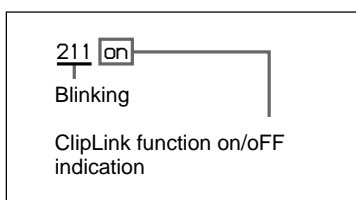

If the setting does not need to be changed, press the MENU button to close the menu.

- 2 Press the SHIFT button to make the ClipLink function on/oFF indication start blinking. Press the ADVANCE button to change the indication to oFF.

- 3 Press the RESET/(MENU SET) button and then the MENU button.

The settings are recorded and display window returns to the display shown before the VCR menu.

Menu 212 Selecting Audio Recording Mode

The audio recording mode can be set to either of the following modes.

48-kHz mode (factory setting): Enables two-channel recording mode with 48-kHz sampling frequency.

32-kHz mode: Enables four-channel recording mode with 32-kHz sampling frequency (for CH-1 and CH-2).

- 1 Display menu 212.

The menu number and current audio recording mode is displayed.

Example: 48 (2-channel mode with 48-kHz sampling frequency)

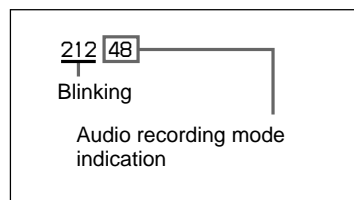

If the setting does not need to be changed, press the MENU button to close the menu.

- 2 Press the SHIFT button to make the audio recording mode indication start blinking, then press the ADVANCE button.

This switches the mode setting to the other audio recording mode.

Example: 32 (4-channel mode with 32-kHz sampling frequency)

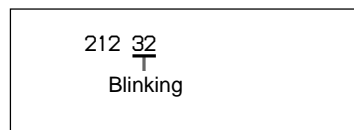

- 3 Press the RESET/(MENU SET) button and then the MENU button.

The settings are recorded and display window returns to the display shown before the VCR menu.

Menu 213 Selecting Audio Reference Level

The audio reference level can be set to either of the following.

-20 dB (factory setting for DSR-500WSL) or -18 dB

(factory setting for DSR-500WSPL): Audio reference level for professional use

-12 dB: Audio reference level commonly used for consumer DV (The maximum level is 0 dB.)

1 Display menu 213.

The menu number and current audio reference level is displayed.

Example: -20 dB (for DSR-500WSL) or -18 dB (for DSR-500WSPL)

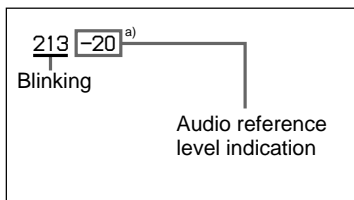

a) For DSR-500WSPL: -18

If the setting does not need to be changed, press the MENU button to close the menu.

2 Press the SHIFT button to make the audio reference level display start blinking, then press the ADVANCE button.

This switches the setting to the other audio reference level.

Example: -12 dB

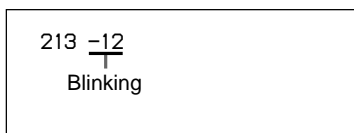

3 Press the RESET/(MENU SET) button and then the MENU button.

The settings are recorded and display window returns to the display shown before the VCR menu.

When using the camcorder in a editing system containing both consumer DV and professional equipment, setting the audio reference level to -12 dB is recommended.

Changing the audio reference level setting from -20 dB (or -18 dB) to -12 dB increases the audio recording level by 8 dB (or 6 dB) whether the AUDIO SELECT (CH-1/CH-2) switch is set to AUTO or MANUAL.

Menu 214 Setting Fade-In/Fade-Out for the Audio Recording Start and Stop Points

You can reduce noise at back space editing points (if necessary) by setting the fade-in/fade-out to on. The fade-in/fade-out transition time is within one frame ($1/30$ second for DSR-500WSL or $1/25$ second for DSR-500WSPL).

Note

When an external equipment, such as a VCR, is connected to the DV OUT connector, the fade-in/fade-out function is turned off automatically regardless of the setting on the menu 214.

1 Display Menu 214.

The fade-in/fade-out is factory-set to OFF.

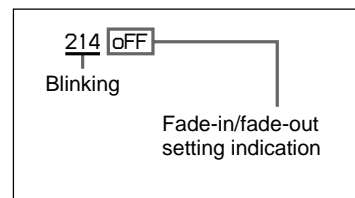

If the setting does not need to be changed, press the MENU button to close the menu.

2 Press the SHIFT button to make the fade-in/fade-out setting indication start blinking, then press the ADVANCE button to change the setting to on.

3 Press the RESET/(MENU SET) button and then the MENU button.

The settings are recorded and the display window returns to the display shown before the VCR menu.

Menu 220 Using Setup Add (for DSR-500WSL Only)

Use this menu to add setup to the playback video signals.

- 1 Display menu 220.

The setup add is factory-set to OFF.

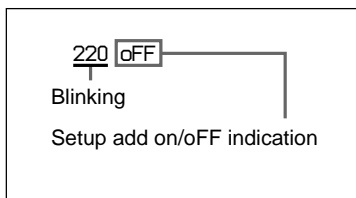

If the setting does not need to be changed, press the MENU button to close the menu.

- 2 Press the SHIFT button to make the setup add on/OFF indication start blinking, then press the ADVANCE button to change the setting to on.
- 3 Press the RESET/(MENU SET) button and then the MENU button.

The settings are recorded and display window returns to the display shown before the VCR menu.

Note

During recording the signal of the image being shot contains setup add, when it is output from the camcorder's S VIDEO OUT and MONITOR OUT connectors.

During playback, the setup is removed from the output video signal.

To have the setup added during playback, set the setup add to on.

Menu 221 Using Setup Remove (for DSR-500WSL Only)

Use this menu to remove setup from the video signal which contains setup (when the DSBK-501/501P is fitted).

- 1 Display menu 221.

The setup remove is factory-set to on.

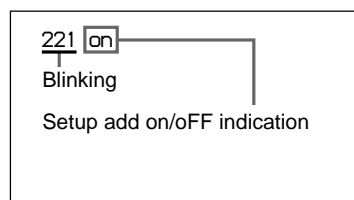

If the setting does not need to be changed, press the MENU button to close the menu.

- 2 Press the SHIFT button to make the setup remove on/OFF indication start blinking, then press the ADVANCE button to change the setting to on.
- 3 Press the RESET/(MENU SET) button and then the MENU button.

The settings are recorded and display window returns to the display shown before the VCR menu.

Note

Even if you set setup remove to on, the video signals output from the camcorder's MONITOR OUT connector during recording will contain setup. However, the signals removed setup are recorded onto a tape.

White Balance Adjustment

Adjusting the white balance ensures that as lighting conditions change white objects remain white in the image and tones remain natural.

The color of light emitted varies from one light source to another, and as the lighting changes the apparent color of an illuminated subject changes. It is therefore necessary to adjust the white balance each time the principal lighting source changes.

Saving an Appropriate White Balance Value in Memory

You can save two white balance values in separate memories, A and B. Unless changed, the saved values are retained for approximately ten years, even when the camcorder is powered off.

Once a value is saved, you can automatically restore the adjustment by moving the W. BAL switch to the A or B position. This makes shooting under alternating lighting conditions easy.

Separate white balance values for each FILTER control setting

In the default case, as described above, the same two A and B white balance values apply to all settings of the FILTER control. It is possible, however, to change the AWB MEM setting in advanced menu page 3 (see page 88) so that there are eight possibly different values for each of the A and B positions and for the four FILTER control settings.

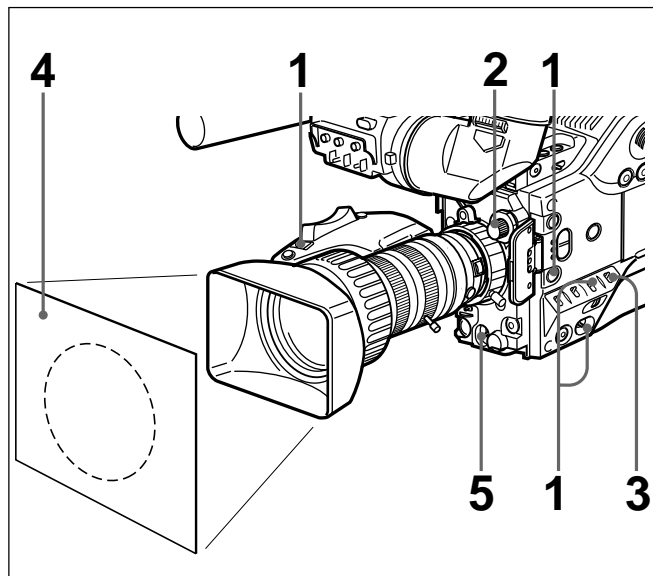

- 1 Make the following settings.
 - POWER switch: ON
 - OUTPUT/DL/DCC+ switch: one of the CAM positions
 - Lens IRIS selector: A (automatic)
 - ATW button: off
- 2 Set the FILTER control according to the lighting conditions. (See page 49.)
- 3 Set the W. BAL switch to A or B.
- 4 Arrange a white subject (paper, cloth, etc.) under the same lighting conditions as for shooting, and zoom in on it so that as far as possible the whole screen is white.

The minimum white area requirements for the adjustment are shown in the following figure.

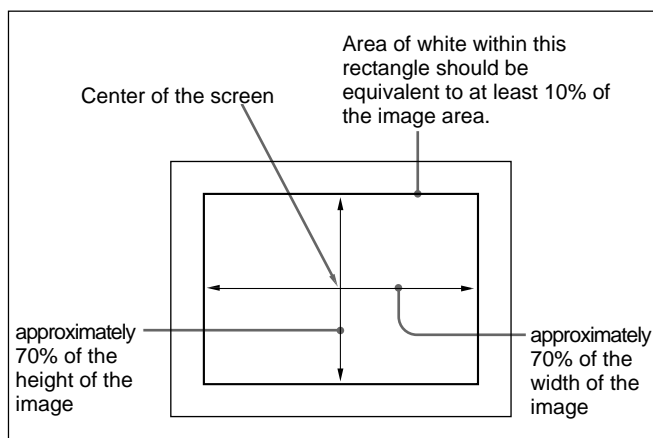

- 5 Push the WHT/BLK switch in the WHT direction and release. The white balance adjustment is carried out. During the adjustment the legend "AUTO WHITE -OP-" appears in the viewfinder. After a few seconds the adjustment is complete, and the legend in the viewfinder changes to "AUTO WHITE -OK-" plus a color temperature, as shown in the following figure.

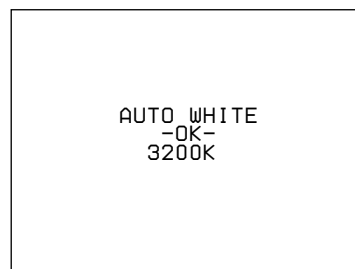

The adjustment value is automatically saved in memory A or B as selected above.

To save the white balance adjustment for different lighting conditions, repeat steps **2** to **4** on the previous page. You can save two different values for the white balance, in memories A and B.

To recall a white balance value from memory

Before beginning shooting, set the W. BAL switch to the A or B position. This automatically sets the camcorder to the white balance adjustment saved in the corresponding memory.

If white balance adjustment cannot be completed automatically

The warning message “AUTO WHITE -NG-” appears in the viewfinder.

Make the necessary corrections, then carry out the process again.

Warning messages for white balance adjustment

Message	Meaning and corrections to be made
AUTO WHITE -NG- :LOW LIGHT TRY AGAIN	Light level is too low. <ul style="list-style-type: none"> • Increase the illumination level, open the iris, or use the GAIN switch to increase the video signal level. • Check the setting of the FILTER control. • After these checks, retry the adjustment.
AUTO WHITE -NG- : ?? TRY AGAIN	The subject is not white, or the lighting level is too high. <ul style="list-style-type: none"> • Use a white subject. • Lower the illumination level, close the iris, or use the GAIN switch to decrease the video signal level. • Check the setting of the FILTER control. • After these checks, retry the adjustment.
AUTO WHITE -NG- :C.TEMP.LOW CHG.FILTER TRY AGAIN	The color temperature is too low. Try the following, in this order of precedence. <ol style="list-style-type: none"> (1) If the FILTER control is in position 2, 3 or 4, change it to position 1, then retry the adjustment. (2) Check that the subject is completely white, then retry the adjustment. (3) The color temperature may be beyond the range of the camcorder. Fit an appropriate color temperature conversion filter, then retry the adjustment.

AUTO WHITE -NG- :C.TEMP.HI CHG.FILTER TRY AGAIN	The color temperature is too high. Try the following, in this order of precedence. <ol style="list-style-type: none"> (1) If the FILTER control is in position 1, change it to position 2, 3 or 4, then retry the adjustment. (2) Check that the subject is completely white, then retry the adjustment. (3) The color temperature may be beyond the range of the camcorder. Fit an appropriate color temperature conversion filter, then retry the adjustment.
WHITE:PRESET	The W. BAL switch is in the PRESET position. Move the W. BAL switch to the A or B position.
BARS	The camcorder is outputting a color bar signal. Move the OUTPUT/DL/DCC+ switch to one of the CAM positions.

Using the Preset White Balance Settings

The camcorder provides two preset white balance settings, for instant shooting with approximately the correct adjustment.

There are also particular shooting conditions under which the preset values may give better results than the human eye adjustment.

1 Set the W. BAL switch to PRESET.

2 Set the FILTER control.

The white balance is automatically adjusted for 3200 K when the FILTER control is in position 1 and for 5600 K in position 2, 3 or 4.

You can change those values (3200K and 5600K) to other values in basic menu page 2 (*see page 81*).

White Balance Adjustment

Light Sources and Color Temperature

Adjustment of the white balance to match the light source is essential to ensure correct color rendering. The color of a light source is indicated as a color temperature in kelvins (K). It is higher for bluish light, and lower for reddish light. When the camcorder is shipped it is adjusted for use with video lights (studio lamps with a color temperature of 3200 K). For use with other light sources, therefore, adjustment is required.

First use the FILTER control to set the approximate color temperature, then carry out white balance adjustment.

The following table shows typical color temperature values for different light sources.

Color temperatures of different light sources

Light source		Color temperature (K)	
Natural	Artificial		
Clear sky		↑	10,000
Light cloud		↑	8,000
Cloudy or rainy skies		Blue light	7,000
		↑	6,000
	Fluorescent light (daylight white)	↓	5,000
Direct sunlight, noon	Mercury lighting	White light	
	Fluorescent light (white)	↑	
One hour after sunrise or before sunset		↓	4,000
	Fluorescent light (warm white)	↓	3,500
	Studio lighting	↓	3,200
	Halogen lamps and video lights	Yellow light	3,000
Thirty minutes after sunrise or before sunset	Incandescent lighting	↓	2,500
	Sodium street-lighting	↓	
Sunrise or sunset	Candlelight	Red light	2,000

Using the ATW (Auto Tracing White Balance) Function

The ATW function continuously adjusts the white balance automatically to adapt to changes in lighting conditions.

Note

Depending on the shooting conditions, automatic adjustment may not necessarily give optimum results. For the best possible results, use the W. BAL switch.

To use the ATW function

Press the ATW button turning the indicator on. This activates the ATW function, and the ATW indication appears in the viewfinder.

To disable the ATW function, press the ATW button again, turning the indicator off.

If the ATW function does not operate correctly

A warning message appears in the viewfinder as shown in the table below.

Message	Meaning and correction to be made
:C.TEMP.LOW	If the FILTER control is in position 2, 3 or 4, change it to position 1, then retry the ATW operation.
:C.TEMP.HIGH	If the FILTER control is in position 1, change it to position 2, 3 or 4, then retry the ATW operation.

Black Balance Adjustment

Correct adjustment of the black balance is important for optimum operation of a camcorder. It is necessary when using the camcorder for the first time or after a significant period out of use, and also when there has been a sudden change in temperature.

The adjustment value is saved in memory, and readjustment is not normally necessary after powering the camcorder off or simply when lighting conditions change.

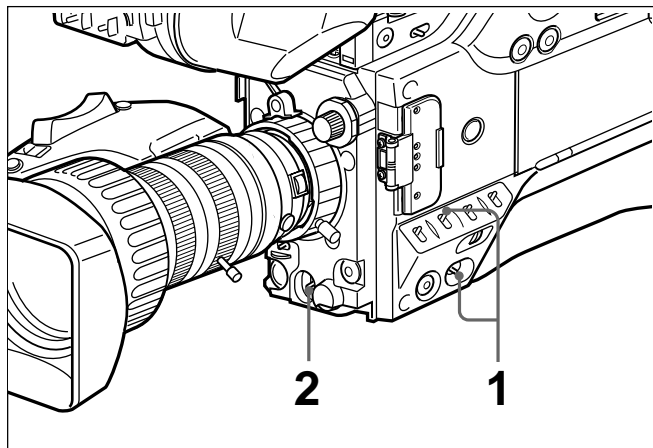

- 1** Turn on the power and check that the OUTPUT/DL/DCC+ switch is in one of the CAM positions.
- 2** Push the WHT/BLK switch in the BLK direction and release.
The lens iris closes, and black balance adjustment is carried out.
During the adjustment the legend “AUTO BLACK -OP-” appears in the viewfinder.

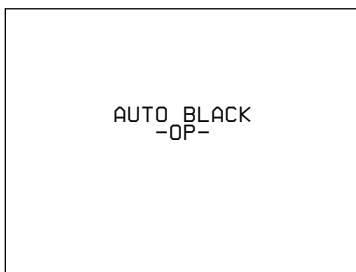

After a few seconds the adjustment is complete, and the legend in the viewfinder changes to “AUTO BLACK -OK-”.

If black balance adjustment cannot be completed automatically

The warning message “AUTO BLACK -NG-” appears in the viewfinder.

Make the necessary corrections, then carry out the process again.

Warning messages for black balance adjustment

Message	Meaning and corrections to be made
AUTO BLACK -NG- : IRIS NOT CLOSED TRY AGAIN	The lens iris did not close fully. Check whether the lens cable is connected properly, and whether there is a fault in the lens. If a second attempt to carry out the adjustment fails, consult your Sony dealer.
AUTO BLACK -NG- : ?? TRY AGAIN	The iris opened during adjustment or there is a hardware error. Close the iris and try again. If this fails, consult your Sony dealer.
BARS	The camcorder is outputting a color bar signal. Move the OUTPUT/DL/DCC+ switch to one of the CAM positions.

Shutter Settings

This section covers the settings for electronic shutter speed, CLS (clear scan) and EVS function. The new value for the shutter speed or clear scan frequency and EVS setting remains set until changed, even when the camcorder is powered off.

Shutter speeds

There are five shutter speeds, from $1/100$ s (DSR-500WSL) or $1/60$ s (DSR-500WSPL) to $1/2000$ s. Increasing the shutter speed reduces blurring when shooting a fast-moving subject. It is also possible to reduce flicker when shooting under fluorescent lighting by changing the shutter speed.

CLS (Clear Scan) function

When shooting a computer screen or projected image, horizontal bands may appear in the camcorder image. This is because the vertical scan frequency of the computer-generated image is different from the vertical scan frequency of the video system. The clear scan function allows you to select a vertical scan frequency to reduce this interference.

EVS (Enhanced Vertical Scan)

This function enhances the vertical scan resolution from 400 to 450 lines (or 450 to 530 lines) to reduce flicker. However, this increases the aliasing.

Setting the shutter speed, CLS and EVS function

Notes on setting the shutter speed

- The faster you make the shutter speed, the darker the image becomes. Check the brightness in the viewfinder, and if necessary increase the lighting level or adjust the iris.
- When the shutter speed is very fast, shooting a high intensity subject may cause long vertical tails to appear on the highlights (smear).

Note on setting the CLS function

The vertical scan frequencies of computer screens vary, and it may not be possible to eliminate the interference patterns entirely. Note also that the vertical scan frequency may change depending on the software being run.

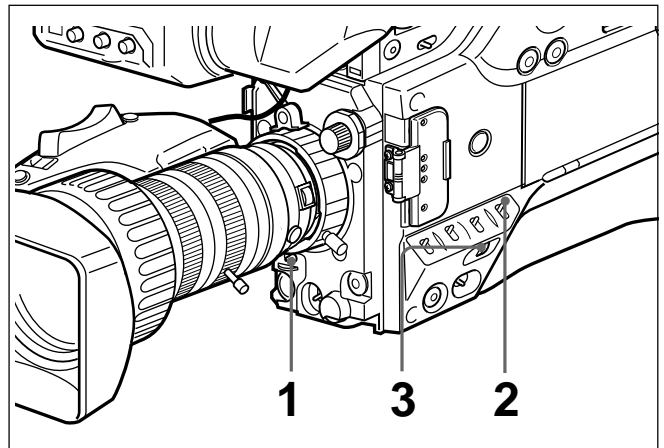

- 1 Set the SHUTTER switch to the ON position.

The SHUTTER indicator in the viewfinder comes on, and it is now possible to change the shutter speed or clear scan frequency setting and to set the EVS function. (If the EVS is already selected, the SHUTTER indicator will not light.)

- 2 Operate the MENU switch and MENU dial to align the cursor with the item "SHUTTER" in basic menu page 1, then press the MENU dial.

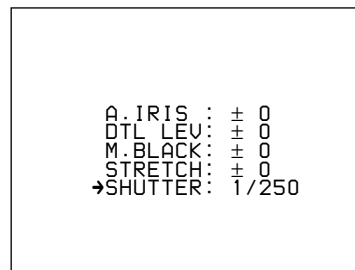

- 3 Turn the MENU dial to select the required shutter speed, scan frequency or EVS.

The shutter speed or clear scan frequency setting changes in the following order:

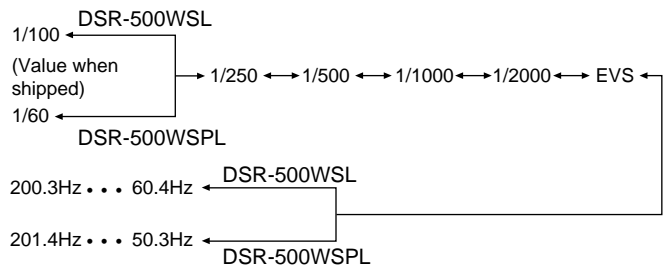

When using the clear scan function

Watching the monitor screen, adjust the frequency to give minimum interference.

If there is a black band in the monitor image, reduce the frequency, and if there is a white band, increase the frequency.

To return from the basic menu to the normal indications

Press the MENU switch repeatedly until the normal indications appear. The new setting of the shutter speed, clear scan frequency, or EVS appears in the normal screen display.

When shooting is finished

Set the SHUTTER switch to the OFF position. The SHUTTER indicator in the viewfinder goes off.

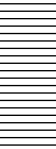

Viewfinder Screen Adjustments

The following adjustments are provided to improve the visibility of the viewfinder screen.

Although these adjustments may make the viewfinder image clearer, they have no effect on the output video signal from the camcorder.

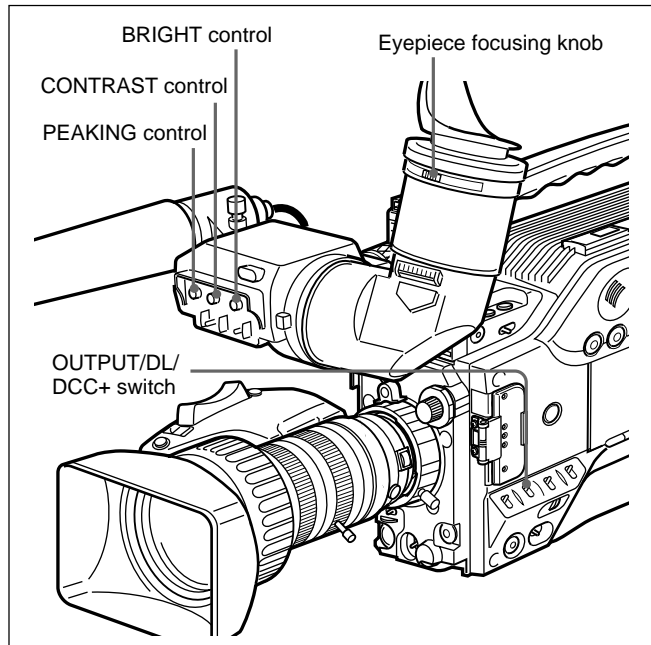

Contrast and brightness adjustment

Carry out these adjustments with the color bars displayed.

- 1 Set the OUTPUT/DL/DCC+ switch to the BARS position.

The color bars appear in the viewfinder.

- 2 Watching the color bars, turn the CONTRAST and BRIGHT controls to adjust the contrast and brightness.
- 3 Return the OUTPUT/DL/DCC+ switch to its original position.

Outline emphasis adjustment

Turning the PEAKING control changes the degree of outline emphasis in the viewfinder image, to make focusing easier.

Adjusting the eyepiece focus

Depending on the eyesight of the operator — whether longsighted or shortsighted — the optimal position of the viewfinder image varies. Adjust the eyepiece focus to get the clearest viewfinder image for your eyesight. First focus the image with the lens, then adjust the eyepiece focusing knob. The adjustment range is from -3 to 0 diopters¹⁾ (default when shipped is 0 diopters).

Using an optional part allows you to modify the adjustment range to -2 to $+1$ diopters or -0.5 to $+3$ diopters.

For details, consult your Sony dealer.

1) **Diopter:** A unit to indicate the degree of convergence or divergence of a bundle of rays.

Adjusting the Lens

Flange Focal Length Adjustment

It is necessary to adjust the flange focal length (the distance from the lens flange to the plane of the image along the optical axis) in the following cases.

- When a lens is fitted for the first time
- After changing lenses
- When during zoom operations the focus does not match properly from telephoto to wide angle

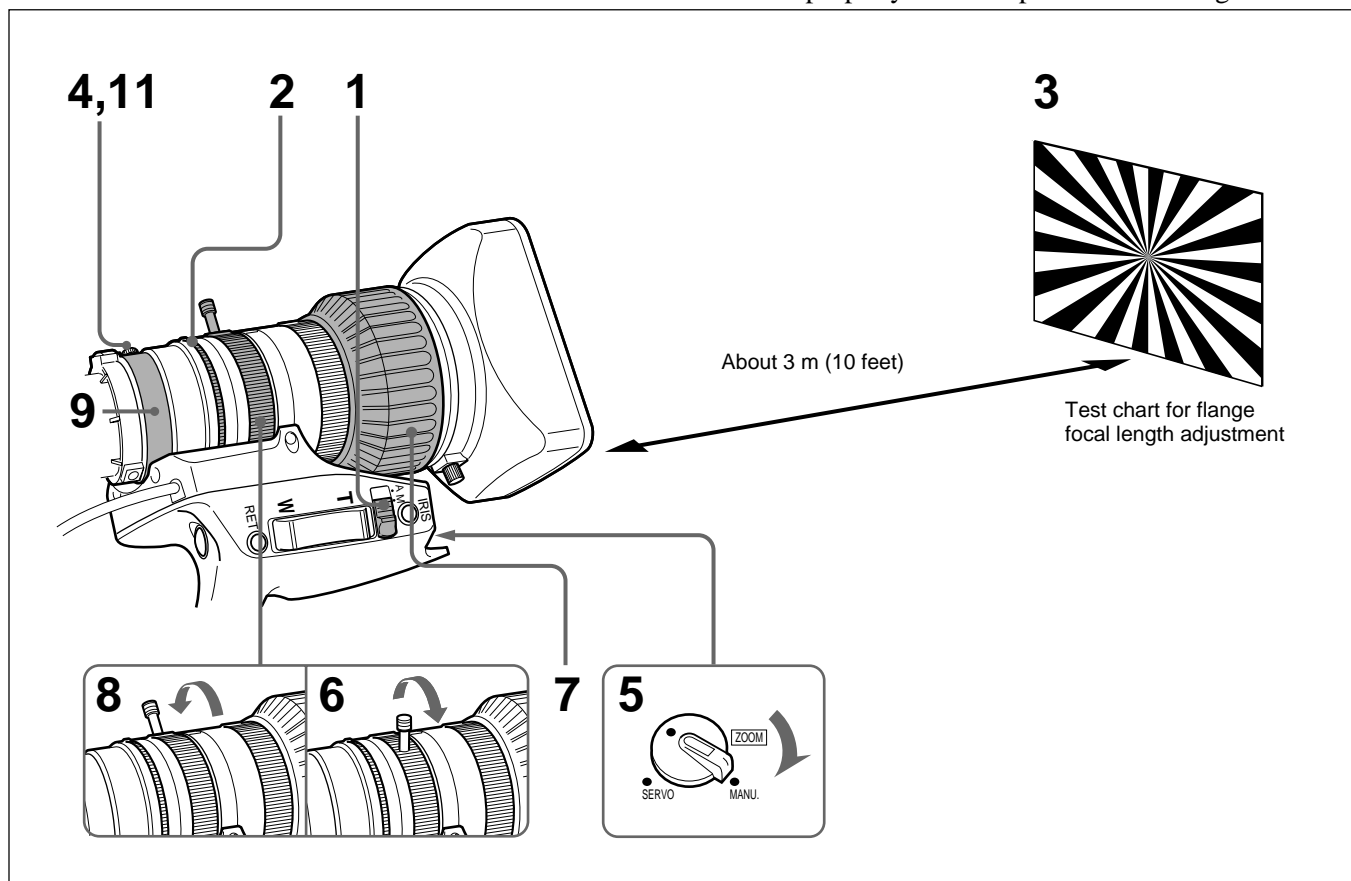

- 1** Set the IRIS selector to the M position.
- 2** Turn the iris ring to F/1.8 (fully open).
- 3** Place the supplied test chart for flange focal length adjustment at a range of about 3 meters (10 feet), and adjust the lighting so that an appropriate video output level is obtained with the iris at F/1.8.
- 4** Loosen the F.B fixing knob.
- 5** Set the ZOOM selector to the MANU. position.
- 6** Turn the zoom ring to the telephoto position.
- 7** Turn the focus ring so that the test chart is in focus.
- 8** Turn the zoom ring to the wide angle position.
- 9** Turn the F.B adjustment ring so that the test chart is in focus. Do not move the focus ring.
- 10** Repeat steps **6** to **9** until the image stays in focus from telephoto to wide angle.
- 11** After adjustment, tighten the screw of the F.B fixing knob.

Adjusting the Lens

Iris Adjustments

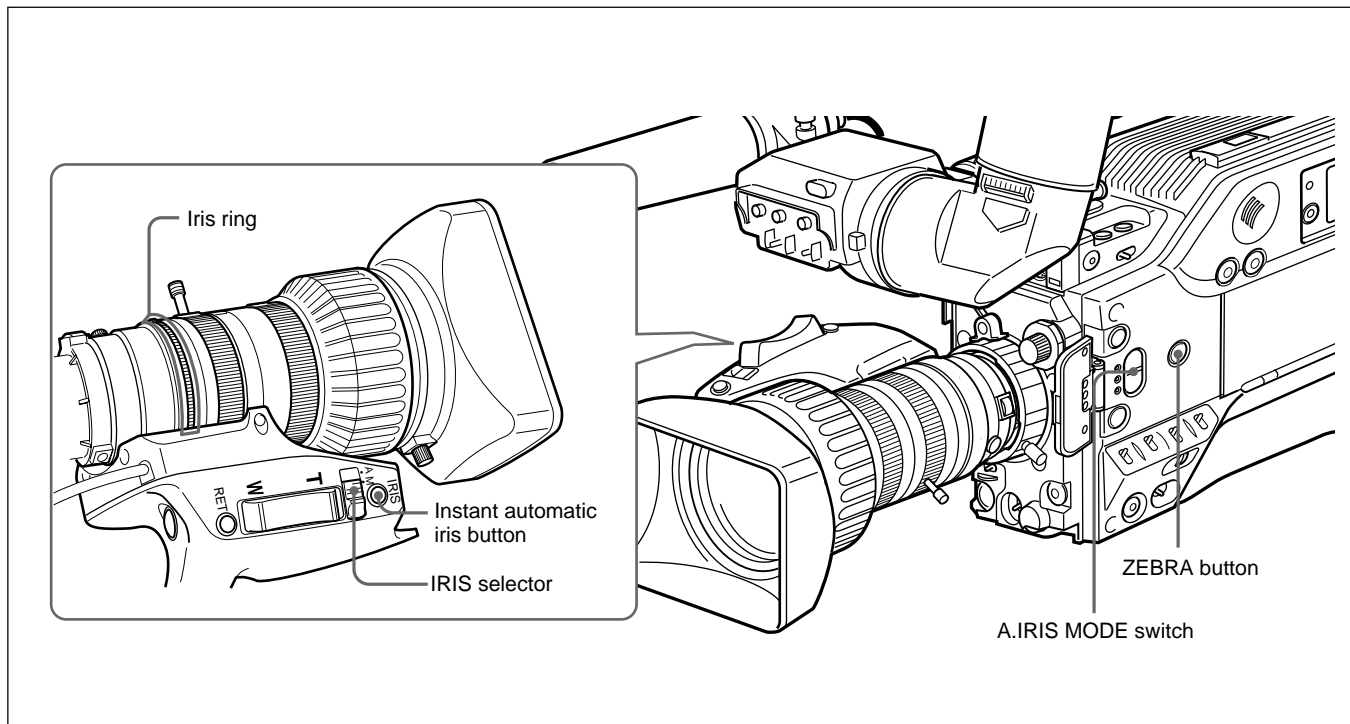

There are three ways of adjusting the iris: automatically, manually, and with the instant automatic iris adjustment function.

Iris adjustment

Adjustment method	Operation
<p>Automatic adjustment mode The iris is adjusted automatically to adapt to changes in the brightness of the subject. This is the mode for normal shooting.</p>	Set the IRIS selector to the A position.
<p>Manual adjustment mode Use this mode in the following cases:</p> <ul style="list-style-type: none"> • For special effects • When filming a person with a very bright sky background • When shooting a subject with extreme contrast <p>The zebra pattern can be used as a guideline for iris adjustment.</p>	Set the IRIS selector to the M position and turn the iris ring as required.
<p>Instant automatic adjustment function While in manual adjustment mode, this function makes a temporary automatic adjustment.</p>	With the IRIS selector in the M position, hold down the instant automatic iris button for as long as necessary.

To make the image lighter when shooting against the light

In the automatic iris adjustment mode, set the A.IRIS MODE switch to BACK L, turning the indicator on.

To make the image clearer when shooting a subject lit by a spotlight

In the automatic iris adjustment mode, set the A.IRIS MODE switch to SPOT L, turning the indicator on.

Using the zebra pattern in manual adjustment mode

To use the zebra pattern as a guideline for iris adjustment in manual adjustment mode, press the ZEBRA button to set it on.

Select the zebra pattern to be displayed in advanced menu page 4 (see page 89).

• When the subject is a person

Adjust the iris manually so that the zebra pattern appears on the highlights of the subject's face.

• For other subjects

Adjust the iris manually so that the zebra pattern appears on the most important parts of the subject.

Designating the lens

You have to designate the lens number according to the types of your lens.

If the number is not designated properly, strange color may appear on the upper and lower of the screen when shooting a white subject.

Set the number in advanced menu page 4 (page 89)

Lens number	Product
1	Fujinon: VCL-916BYA, A16X9 BRM, A12X6.8 BRM Canon: VCL-918BY, YJ18X9B KRS
2	Fujinon: A10X4.8 BEVM/BERD, A15X8 BERM/BERD, A16X9 BERM, A20X8 BEVM/BERD, A19X8.7 BERM, A19X8.7 BRM Canon: J9aX5.2B IRS/IAS, J15aX8B IRS/IAS
3	Canon: J21aX7.8B IRS/IAS, YJ18X9B IRS
4	Set up the data with Sony dealer.

If you use the lens that is not mentioned above, set the lens number as follows:

- When using the lens without the extender, set it to 1.
- When using the lens with the extender, set it to 2.
- When using the lens with the ratio converter, set it to 2.

You can also set it more precisely at Sony dealer, according to your lens. In this case, set it to 4.

Adjusting the Iris Sensitivity

You usually need not adjust the iris sensitivity because lenses are equipped with iris sensitivity adjustment function.

In auto iris mode, if hunting or response delay happens, adjust the iris sensitivity using the iris sensitivity trimmer.

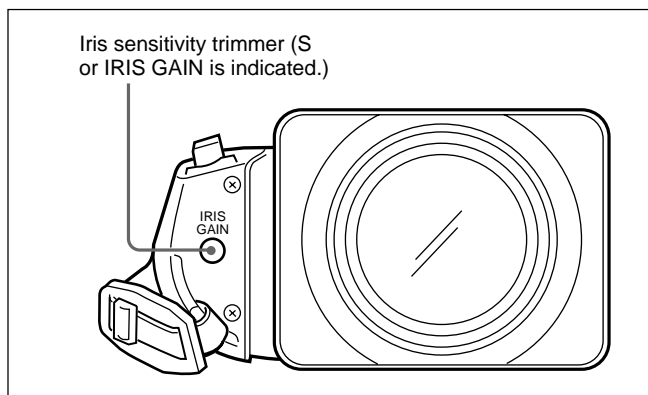

You can see the iris sensitivity trimmer when removing the gum cap on the front of the lens driving unit. Use a mini-screwdriver to turn the trimmer. If you turn it clockwise, the sensitivity increases, and if you turn it counterclockwise, the sensitivity decreases. It is recommended that you confirm the iris sensitivity after replacing the lens.

For more information, refer to the operating instructions for the lens (or consult the lens maker).

Macrophotography

Use the macro function when the subject is short from the front of the lens.

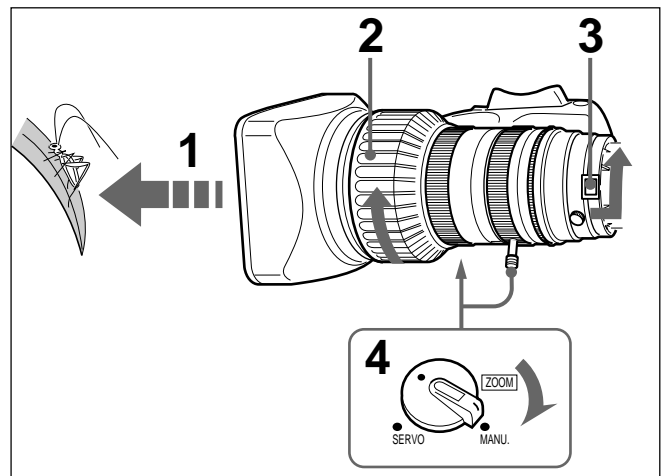

- 1 Bring the lens up to the subject so that the image is the required size.
- 2 Move the focus ring to the closest focus position.
- 3 Press the M button and turn the MACRO ring fully in the direction shown by the arrow.
- 4 Move the ZOOM selector to the MANU. position, and turn the zoom ring to focus the image.

Ending close-up shooting

Return the MACRO ring to its original position (turn fully in the opposite direction to the arrow in the figure).

Reducing the size of the image

After completing steps 1 to 4 above, if you wish to reduce the size of the image, turn the MACRO ring back slightly, then use the zoom ring again to focus the image.

Settings for Special Cases

Settings for special cases

Shooting conditions	Setting	Effect
The background is very bright, and the subject is too dark.	Set the A.IRIS MODE switch to BACK L, turning the indicator on.	This lightens the foreground.
The subject is under a spotlight.	Set the A.IRIS MODE switch to SPOT L, turning the indicator on.	This prevents white burn-out in highlights of faces and clothes.
The subject is completely still (e.g. when shooting documents, drawings, etc.).	Enable the EVS (Enhanced Vertical definition System) function. (See page 116.) Note Enabling the EVS function tends to increase the occurrence of aliasing problems (moiré patterns). Therefore, normally leave the function disabled.	This enhances the vertical resolution.
When you wish to give a lush effect, as when shooting a wedding or similar occasion.	Set the FILE setting to HISAT. (See page 94.)	This increases the saturation of primary colors.
Shooting under fluorescent lighting.	Set the FILE setting to FL. (See page 94.)	This eliminates the blue-green cast, and restores natural hues.
When shooting bright areas mixed with dark areas (Example: A person indoors looking through a window at a bright landscape outdoors).	Set DL to ON in the advanced menu page 2, then set the OUTPUT/DL/DCC+ switch to CAM /DL. (See page 88.)	Prevents white breakup and color faults in bright areas.
When adjusting for skin detail or tone (Example: When shooting to hide skin details).	See "Skin Detail Correction" (page 123) or "Adjusting Color in the Specified Area" (page 123).	Adjusts the skin detail or tone to a designated active area.
To make focusing before shooting easier.	Press the EZ FOCUS button, turning the "easy focus" function on. (See page 13.)	This opens the iris, to make it easier to focus before beginning shooting.
To begin shooting immediately when there is no time to make adjustments.	Press the EZ MODE button, turning the "EZ mode" function on. (See page 14.)	This provides automatic adjustment to a set of standard values, to allow immediate shooting.
The 3200 K preset white balance makes the picture reddish.	Change the setting of the preset white balance on basic menu page 2. (See page 81.)	This prevents the picture from reddening.

Skin Detail Correction

The DSR-500WSL/500WSPL provides an easy push-button function that designates an active skin tone area.

Note

The SKIN DTL SET button is disabled while a title is displayed in basic menu page 8 or color bars are displayed. Before skin detail correction, clear the title or color bars display.

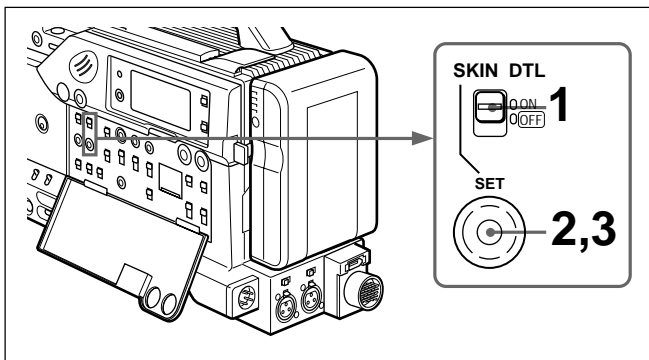

- 1 Set the SKIN DTL switch to ON.

The indication “SKIN AREA: ±0” appears in the viewfinder.

- 2 Press the SKIN DTL SET button.

This causes the area detect cursor to be shown in the viewfinder (for 10 seconds).

- 3 Place the area detect cursor on the target, then press the SKIN DTL SET button.

This designates the correction area, which is indicated by a zebra pattern, and the indication “SKIN AREA: ±0” appears again. If the area detect cursor disappears before designating the area, press the SKIN DTL SET button again to display the cursor. (Returns to step 2.)

- 4 Turn the MENU dial to change the SKIN AREA value (–99 to +99) so that the zebra pattern may be displayed in the target area. Use basic menu page 1 to set the correction level (see page 80).

You can also change color in the designated area (see the following section).

Adjusting Color in the Specified Area

You can adjust the color of the specified area. Perform the same procedure as for the skin detail correction to designate the target area.

- 1 Turn the POWER switch on with holding down the MENU dial so that you can access the advanced menu.
- 2 Display the advanced menu page 12.

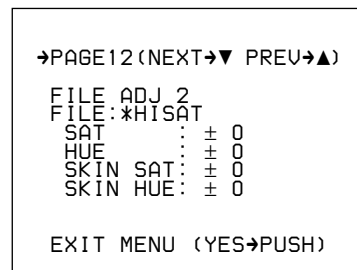

- 3 Perform the procedure for the skin detail correction to designate the area to which you apply color adjustment.

While this procedure is being performed, the menu is not displayed.

- 4 When advanced menu page 12 appears, change the value of the SKIN SAT and SKIN HUE to adjust color in the area designated in step 3.

Note

Set SKIN DTL to 1.0 in basic menu page 2 if the skin detail correction is unnecessary.

Important Notes on Operation

Fitting the zoom lens

It is important to fit the lens correctly, as otherwise damage may result. Be sure to refer to the section "Fitting the Lens" (See page 32).

Do not cover the unit while operating

Putting a cloth, for example, over the unit can cause excessive internal heat build-up.

Operation and storage

Avoid storing or operating the unit in the following conditions.

- In excessive heat or cold (operating temperature range: 0°C to 40°C (32°F to 104°F))
Remember that in summer in warm climates the temperature inside a car with the windows closed can easily exceed 50°C (122°F).
- In damp or dusty locations
- Locations where the unit may be exposed to rain
- Locations subject to violent vibration
- Do not use the unit close to strong magnetic fields.
- Close to radio or TV transmitters producing strong electromagnetic fields.

Viewfinder

- Do not leave the unit with the eyepiece pointing directly at the sun.
The eyepiece lens can concentrate the sun's rays and melt the interior of the viewfinder.
- Do not use the viewfinder close to strong magnetic fields. This can cause picture distortion.

Avoid violent impacts

Dropping the unit, or otherwise imparting a violent shock to it, is likely to cause it to malfunction.

After use

Set the POWER switch to OFF to turn off the power.

When not use for a period time

Remove the battery pack.

Shipping

- Remove the cassette before transporting the unit.
- If sending the unit by truck, ship, air or other transportation service, pack it in the shipping carton of the unit.

Care of the unit

Remove dust and dirt from the surfaces of the lenses or optical filters using a blower.

If the body of the unit is dirty, clean it with a soft, dry cloth. In extreme cases, use a cloth steeped in a little neutral detergent, then wipe dry. Do not use organic solvents such as alcohol or thinners, as these may cause discoloration or other damage to the finish of the unit.

In the event of operating problems

If you should experience problems with the unit, contact your Sony dealer.

Characteristics of CCD Sensors

The following effects may appear in the image. They are characteristic of camcorders using CCDs (charge-coupled devices), and do not indicate a malfunction.

Vertical smear

When shooting a very bright object, such as a light, the highlight tends to produce vertical tails. This effect is much reduced in this camcorder. (Use of the electronic shutter increases this effect.)

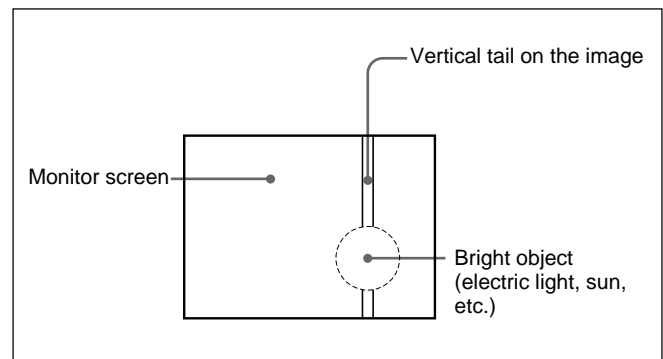

White flecks

If the camcorder is operated at a high temperature, white flecks may appear in the image. White flecks may also appear under normal temperature conditions if the sensitivity is increased (especially to +18 dB or higher).

Cleaning the Video Heads

Always use the special-purpose Sony PDVM-12CL Cleaning Cassette for cleaning the audio and video heads. Follow the instructions with the cleaning cassette carefully, as inappropriate use of the cleaning cassette can damage the heads.

Note

The PDVM-12CL Cleaning Cassette can be used only once. When the PDVM-12CL is loaded in the camcorder, only STOP, PLAY and EJECT buttons function.

Replacing the video heads

If cleaning the video heads fails to restore picture quality, the heads may be due for replacement. Keep a check of the hours of head drum operation: with normal use, **the heads should need replacing after about 1,500 hours of use.**

When the heads need replacement, contact your Sony dealer.

Check the hours of head drum operation using the VCR menu. For details see "Checking the Total Operating (Power-On) Hours — Menu 201" on page 105.

Replacing other parts

For replacement of all parts other than the video heads, contact your Sony dealer.

Warning System

When the camcorder is powered on, or if a fault occurs during operation, a warning is given in the following ways:

- By warning indications in the display window.
- By means of the WARNING indicator together with a warning tone from the speaker or earphone.

- By the warning indicators in the viewfinder.

You can adjust the volume of the warning tone with the ALARM knob. When this knob is turned to the minimum position, there is no sound output at all.

Operation warnings and action to be taken

Display window		WARNING indication	Warning tones	Viewfinder indicators		Problem	Machine action	What to do
Warning indication	State (blinking/Continuous)		Continuous	REC/TALLY	BATT			
		Continuous 1 blink/s 4 blinks /s	Continuous 1 beep/s 4 beeps /s	Continuous 1 blink/s 4 blinks/s				
RF	Continuous ^{a)}	^{a)}	^{a)}	^{a)}		Video head gaps clogged or problem in recording circuit.	After detecting head clogging, recording continues but quality is poor.	Clean the heads. If the problem persists, power off, and consult your Sony dealer.
SERVO	Continuous ^{a)}	^{a)}	^{a)}	^{a)}		Servo lock lost.	Recording continues but quality is poor. This may temporarily blink when the recording starts.	Power off, and consult your Sony dealer.
HUMID	Continuous					Condensation on head drum.	The VCR stops, and all operations are inhibited except eject.	Without powering off, wait until the HUMID indication disappears.
SLACK	Continuous					The tape cannot be wound properly.	Operation stops.	Consult your Sony dealer before doing anything. ^{d)}
TAPE	Blinking ^{a)} (1 blink/s)	^{a)}	^{c)}	^{c)}		Close to the end of tape.	Operation continues.	Replace the cassette as soon as possible.
	Blinking (4 blinks/s)					End of tape.	Operation stops during recording, playback or fast forward.	Replace the cassette or rewind.
BATT	Blinking (1 blink/s)		^{b)}	^{b)} ^{c)} (Blinking in reverse phase)		Battery almost exhausted.	Operation continues.	Replace the battery as soon as possible.
	Blinking (4 blinks/s)					Battery exhausted.	Operation stops.	Replace the battery.

- a) During recording or at recording pause.
 b) Except during playback, fast forward, rewind, and recording review
 c) During recording only
 d) Do not operate the camcorder with "SLACK" indication displayed or **the tape may be damaged.**

For details of warning messages displayed in the viewfinder, see page 77.

Condensation

If you move a camcorder suddenly from a very cold place to a warm place, or use it in a very humid location, condensation may form on the head drum. If it is operated in this state, the tape may adhere to the drum, and cause a failure or even permanent damage. Take the following steps to prevent this from happening:

- Remove the cassette before moving the camcorder from a very cold place to a warm place.
- Before inserting a cassette, turn the power on, and check that the HUMID indication is not showing in the display window. If it is showing, wait — do not insert a cassette until the HUMID indication disappears. You can save waiting time if you keep the camcorder powered.

For details of cassette insertion and removal, see the section “Recording on the Internal VCR” on page 52, and for details of the HUMID indication, see the section “Warning System” on page 127.

Troubleshooting

You can use this chart to establish possible causes of an apparent problem; always double-check before

sending the unit for repair. If a problem persists, contact your Sony dealer.

Troubleshooting chart

Symptoms	Cause	Remedy
The unit does not power on when you turn the POWER switch on.	There is no battery pack loaded.	Load a battery pack (page 46).
	The battery pack has reached the end of its usable life.	Replace the battery pack with a fully charged one (page 46).
	The AC power adaptor is not connected, or it is not turned on.	Connect the AC power adaptor or turn it on (page 48).
The tape transport does not operate when you press either VTR button.	The POWER switch of the unit is turned off.	Turn the POWER switch on (page 14).
	The unit has reached the end of tape.	Rewind the tape, or load a new cassette (page 53).
	The cassette is set record-inhibited.	Either load a new cassette, or release the record-inhibit (page 51).
	An incorrect type of DVCAM or DV cassette is loaded. (The C// indication blinks.)	Load a correct type of DV or DVCAM cassette (page 51, 53).
The tape transport does not operate when you press any tape transport button.	The unit has reached the end of tape.	Rewind the tape, or load a new cassette (page 53).
	The cassette holder is not solidly closed after the cassette is inserted.	Press on the "PUSH" indication to close the holder solidly (page 53).
The power supply cuts while operating.	The battery pack is exhausted.	Replace the battery pack with a fully charged one (page 46).
The battery goes dead very quickly.	The operating temperature is very low.	Use a BP-L60/L60A or BP-L90/L90A (page 46).
	The battery pack is inadequately charged.	Recharge the battery pack (page 46).
It is not possible to eject the cassette.	The battery pack is exhausted.	Replace the battery pack with a fully charged one (page 46).
	The POWER switch is turned off.	Turn the POWER switch on. (page 14)
	The cassette holder is not solidly closed after the cassette is inserted.	Press on the "PUSH" indication to close the holder solidly and then press the EJECT button (page 53).
The playback picture quality is poor.	The video heads are dirty.	Clean the video heads using a PDVM-12CL Cleaning Cassette (page 126).
The playback picture does not appear.		
The playback sound does not hear.		
All controls except the EJECT button are disabled.	There is condensation on the head drum.	Remove the cassette, power off, and wait until the condensation has evaporated (page 128).
Audio recording is not possible.	The AUDIO LEVEL (CH-1/CH-2) knobs are set to the minimum level.	Adjust the setting of the AUDIO LEVEL (CH-1/CH-2) knobs (page 16).
	The AUDIO LEVEL knob on the front is set to the minimum level.	Adjust the setting of the AUDIO LEVEL knob (page 12).
The recorded sound is distorted.	The audio level is too high.	Adjust the setting of the AUDIO LEVEL (CH-1/CH-2) knobs, and record again (page 16).
The recorded sound has a high noise level.	The audio level is too low.	Adjust the setting of the AUDIO LEVEL (CH-1/CH-2) knobs, and record again (page 16).
The indication "Er91-13F" appears in the display window.	The unit has failed in loading or saving the cassette memory data.	Load a new cassette (page 53).
The cassette is automatically ejected.	An incorrect type of cassette is loaded.	Load a correct type of cassette (page 53).

(Continued)

Troubleshooting

Troubleshooting chart (continued)

Symptoms	Cause	Remedy
The time code setting is not possible.	At the recording, the ClipLink function is set to on (meaning ClipLink shooting is allowed) in menu 211, CONT is displayed in the display window and the time code generator is in the REGEN mode.	Only the REGEN mode can be used for ClipLink shooting. If you will not perform ClipLink shooting, set the ClipLink function to oFF (see page 109).
The time code value does not advance though the TC mode switch 1 or 2 is set to the F-RUN or DATE/TIME.		



Specifications

DSR-500WSL/500WSPL

Imaging element	Three-chip interline transfer CCD
Pixel resolution	980 (horizontal) × 494 (vertical) (DSR-500WSL) 980 (horizontal) × 582 (vertical) (DSR-500WSPL)
Imaging area	9.6 × 5.4 mm (corresponds to 2/3-inch picture tube)
Built-in filter settings	1: 3200K 2: 5600K + 1/8ND 3: 5600K 4: 5600K + 1/64ND
Lens mount	Sony 2/3-inch bayonet mount
Signal standards	EIA standard signal (NTSC color system) (DSR-500WSL) CCIR standard signal (PAL colour system) (DSR-500WSPL)
Scanning system	525 lines, 2:1 interlace (DSR-500WSL) 625 lines, 2:1 interlace (DSR-500WSPL)
Scanning frequencies	Horizontal: 15.734 kHz (DSR-500WSL) 15.625 kHz (DSR-500WSPL) Vertical: 59.94 Hz (DSR-500WSL) 50.00 Hz (DSR-500WSPL)
Synchronization	Internal sync External sync, using signal input (VBS or BS) to the GEN LOCK IN/VIDEO IN connector or input to the VTR connector.
Horizontal resolution ¹⁾	16:9 Mode: 800 TV lines (center) 4:3 Mode: 850 TV lines (center)
Minimum illumination	0.5 lux (at F/1.4, +36 dB) 0.8 lux (at F/1.8, +36 dB)
Sensitivity	2000 lux (F/11.0 standard, 3200 K)
Gain levels	Selectable -3 dB, 0 dB, 3 dB, 6 dB, 9 dB, 12 dB, 18 dB, 18 dB + DPR, 24 dB, 24 dB + DPR, hyper gain

Video S/N ratio (output from the VIDEO OUT connector)	63 dB (typical) (DSR-500WSL) 61 dB (typical) (DSR-500WSPL)
Registration	0.05% for all zones, without lens
Input connectors	AUDIO IN CH-1/CH-2: XLR-3 pin × 2, female -60 dBu, 3 kΩ +4 dBu, 10 kΩ (0 dBu = 0.775 Vrms) GEN LOCK IN: BNC 1.0 Vp-p, 75 Ω VIDEO IN: BNC 1.0 Vp-p, 75 Ω (When fitting DSBK-501/501P. The connector shares with GEN LOCK IN) TC IN: BNC 0.5 to 18 Vp-p, 10 kΩ DC IN: XLR-4 pin, male
Output connectors	DV OUT: 6-pin IEEE1394, × 1 AUDIO OUT CH-1/CH-2: phono jack -10 dBu, 47 kΩ (0 dBu = 0.775 Vrms) VIDEO OUT: BNC, 1.0 Vp-p, 75 Ω MONITOR OUT: BNC, 1.0 Vp-p, 75 Ω S VIDEO OUT: DIN 4 pin 1.0 Vp-p, 75 Ω TC OUT: BNC, 1.0 Vp-p, 75 Ω DC OUT: 4 pin, female EARPHONE: mini-jack -∞ to -15.5 dBu variable, 8 Ω LENS: 12-pin VF: 20-pin VTR: 26-pin LIGHT : 2-pin
Control connectors	REMOTE 1: stereo mini-jack REMOTE 2: 10-pin
Power supply	11 to 17 V DC
Power consumption	24 W
Operating temperature	0°C to 40°C (32°F to 104°F)

1) For details on measuring horizontal resolution, see page 134.

Specifications

Storage temperature

-20°C to +60°C (-4°F to 140°F)

Mass

3.6 kg approx. (7 lb 15 oz)
(camcorder only)

External dimensions in millimeters (inches)

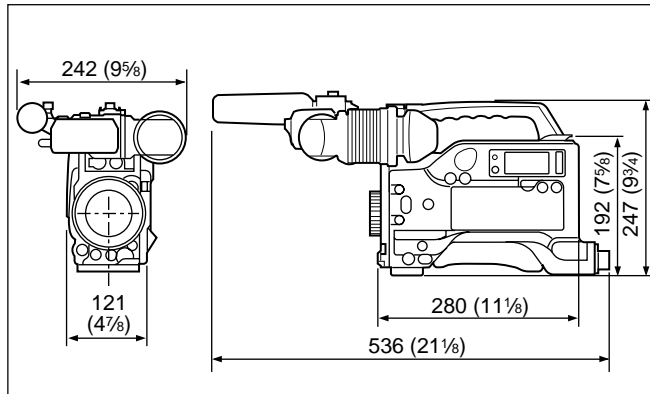

Tape transport system

Tape speed Approx. 28.2 mm/s

Recording/playback time (using PDV-184ME)
Max. 184 minutes

Fast forward/rewind time (using PDV-184ME)
Max. 12 minutes

Usable cassettes

Model name	Size
PDV-64ME/64MEM/94ME/124ME/ 124MEM/184ME/184MEM	Standard size
PDVM-12ME/22ME/32ME/32MEM/ 40ME/40MEM	Mini size

Video system (at playback with the DSR-85/85P)

Bandwidth	Luminance (Y)	DSR-500WSL: 30 Hz to 5.0 MHz \pm 1.0 dB DSR-500WSPL: 25 Hz to 5.5 MHz +1.0/-2.0 dB
	Chrominance (R-Y/B-Y)	DSR-500WSL: 30 Hz to 1.5 MHz +1.0/-5.0 dB DSR-500WSPL: 25 Hz to 2.0 MHz +1.0/-2.0 dB
S/N ratio	Luminance	Min. 55 dB
K-factor (K2T, KPb)		Max. 2%
Y/C time delay		Max. 30 nsec.

Audio system (at playback with the DSR-85/85P)

Frequency response	2-channel mode: 20 Hz to 20 kHz +0.5/-1.0 dB 4-channel mode: 20 Hz to 14.5 kHz +0.5/-1.0 dB
Dynamic range	Min. 80 dB
Distortion (THD) (1 kHz, reference level, 48 kHz)	Max. 0.08%

DXF-801/801CE Viewfinder

Picture tube	1.5-inch monochrome
Indicators	REC/TALLY (\times 2), BATT, TAKE, SHUTTER, GAIN UP
Resolution	600 TV lines
Power supply	12 V DC
Power consumption	2.1 W
Mass	620 g approx. (1 lb 5 oz)
Maximum external dimensions	241 (W) \times 91 (H) \times 203 (D) mm (9 1/2 \times 3 5/8 \times 8 inches)

RM-LG1 Remote Control Unit

Dimensions	85 \times 25 \times 12 mm (3 3/8 \times 1 \times 1/2 inches) (excluding projections)
Mass	Approx. 50 g (1 oz) (including cable)
Cable	5 m (16 feet), with mini-plug
Operating temperature range	-10°C to +45°C (14°F to 113°F)
Storable temperature range	-20°C to +60°C (-4°F to 140°F)
Accessories	Stickers (1 set) Panning rod mounting bracket (1)

Supplied accessories

DXF-801/801CE Viewfinder (1)
Microphone (1)
Wind screen (1)
VCT-U14 Tripod Adaptor (1)
Shoulder strap (1)
RM-LG1 Remote Control Unit (1)
Lens mount cap (1)
Flange focal length adjustment test chart (1)
Binding tie (4)
Operating Instructions (1)

Design and specifications are subject to change without notice.

Related Products

There is a range of Sony products available to meet every conceivable video shooting requirement. For details, consult your Sony sales representative or supplier.

Lenses

VCL-916BYA/918BY Zoom Lens

Remote control unit

RCP-TX7 Remote Control Unit
RM-M7G/LG1/VJ1 Remote Control Unit

VCR products

BVV-5/5P Videocassette Recorder
DNV-5/5P Videocassette Recorder
BVW-50/50P Portable Videocassette Recorder
DSR-20/20P/70/70P/2000/2000P Digital Videocassette Recorder
VA-5/5P/90/90P VTR Adaptor

Battery products

BP-L40/L40A/L60/L60A/L90/L90A Battery Pack
NP-1B/BP-90A Battery Pack
BC-1WD/1WDCE/410/410CE Battery Charger
BC-L50/L100/L100CE Battery Charger

AC power supply

CMA-8A/8ACE AC Adaptor
AC-550/550CE/DN1/DN2A AC Adaptor

Synthesized tuner products

CA-WR855 Camera Adaptor
WRR-810A/855A/860A UHF Synthesized Tuner

Microphone products

ECM-670/672 Electret Condenser Microphone
C-74 Condenser Microphone
CAC-12 Microphone Holder
EC-0.5C2/0.3C2 Microphone Cable

Studio equipment

SEG-2550A/2550AP Special Effects Unit
DFS-300/300P/500/500P DME Switcher
DCK-500/500P Chroma Keyer
WEX-2000 Wipe Pattern Extender
DXF-51 5-inch Viewfinder (monochrome)

Cables and miscellaneous

The suffix number on a cable part number indicates the length in meters: e.g. a CCZ-A2 is 2 meters long.

(Approximate equivalents in feet: 2 m = 6 ft, 5 m = 16 ft, 10 m = 33 ft, 25 m = 82 ft, 50 m = 164 ft, 100 m = 328 ft)

Camera cables with Z-type 26-pin connectors
CCZ-A2/A5/A10/A25

Camera cables with Q-type 14-pin and Z-type 26-pin connectors

CCZQ-A2/A5/A10/A2AM

i.LINK cable (DV connecting cable)

CCFD-3L (6-pin ↔ 4-pin, 3.5 m)

CCF-3L (6-pin ↔ 6-pin, 3.5 m)

DSBK-301A Index Picture Board

DSBK-501/501P Analog Composite Input Board

LCR-1 Rain Cover

LC-DS500 Carrying Case

LC-DS300SFT Soft Carrying Case

Specifications

Measuring Horizontal Resolution

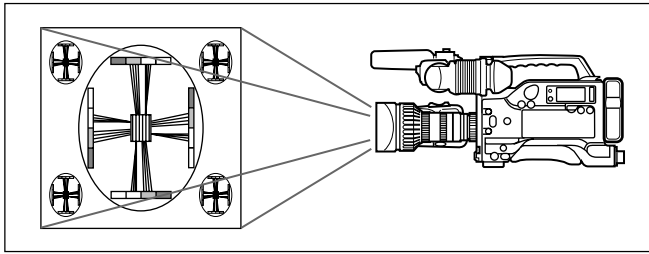

Horizontal resolution in 16:9 mode

When the horizontal image frame of this camera is aligned with the width of the 4:3 resolution chart, the resolution is about 935 TV lines (see Figure A).

However, to measure the resolution of a video camera precisely, the vertical image frame must be aligned with the height of the chart. When this is done, the resolution is approximately 800 TV lines (see Figure B).

Horizontal resolution in 4:3 mode

In 4:3 mode, frame memory is used to extract the 4:3 area from the 16:9 video signals produced by the WS CCD, and the 4:3 signals are electronically enlarged. As a result, the horizontal resolution is approximately 850 TV lines (see Figure C).

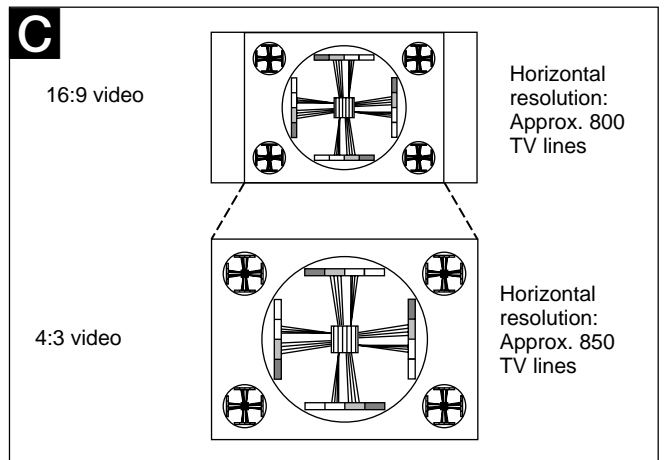
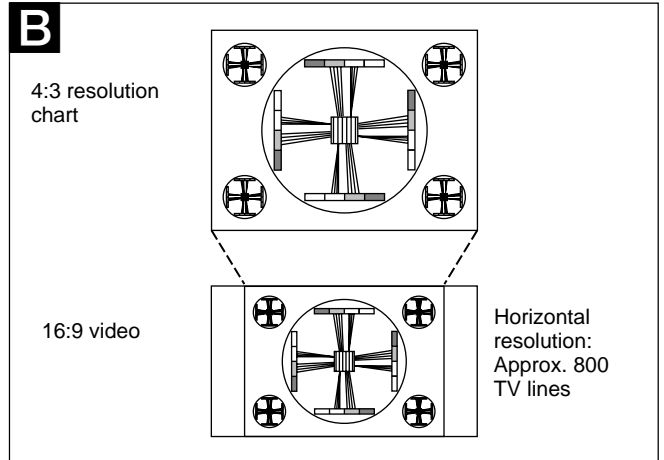
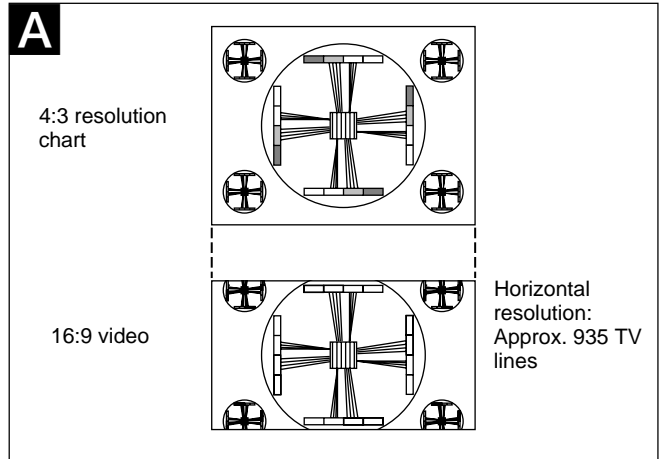
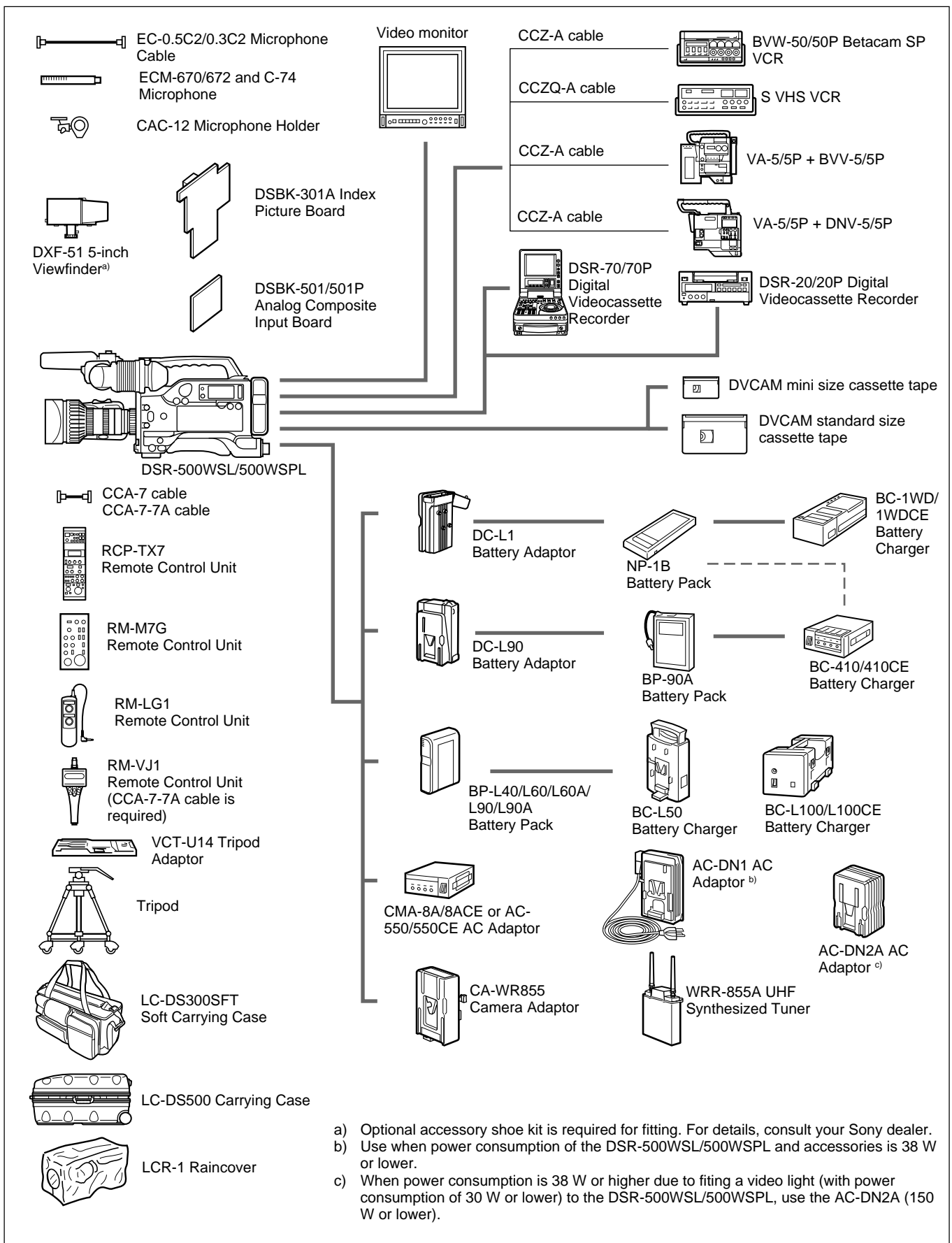

Chart of Optional Components and Accessories



What Is ClipLink?

The ClipLink™ function greatly improves the efficiency of the video production process as a whole by recording various editing-related data on tape when shooting. As such, ClipLink is a revolutionary function that transcends the conventional separation of shooting and editing.

Note

When an external equipment, such as VCR, is connected to the DV OUT connector, the ClipLink function will not work.

How ClipLink Changes Video Production Techniques

The following describes various ways in which ClipLink¹⁾ video production differs from conventional video production.

Recording of ClipLink log data lightens the shooting workload

When you start shooting a scene, ClipLink log data such as the scene number and time code data are automatically recorded into the cassette memory. This eliminates the need for a conventional “shot list” compiled by someone using a stopwatch, clipboard and pencil. You can also designate unwanted scenes as “NG” (no good) and automatically skip all “NG” scenes when editing.

Recorded Index Pictures drastically cut editing time

The ClipLink function also features Index Pictures a time-saving tool for rough editing. Each Index Picture is a compressed image taken from the start of each scene, which is recorded onto the tape as a still picture. When editing, begin by transferring only the Index Pictures and the ClipLink log data to the EditStation’s hard disk. You can also transfer OK scenes only (“NG” scenes are skipped).

Next, begin rough editing by viewing the Index Pictures on the EditStation’s GUI display and rearranging them as you wish. This eliminates the difficult work of matching up a handwritten shot list with recorded scenes. After you have completed this rough editing, you can then transfer only the recordings needed for your video program.

High-speed transfer of recordings

It is also possible to transfer the editing material itself between the DSR-85/85P and ES-7 at four times normal speed. In other words, the transfer can be carried out in one fourth of the real time duration. It is of course possible to carry out a transfer at four times normal speed when backing up video and audio data recorded on the disk drive to the DSR-85/85P, or in the opposite direction when loading data backed up on the DSR-85/85P to the disk drive. Thus the time required is much shorter than with conventional equipment (for which, for example, transferring a 40-minute segment of video takes 40 minutes).

Note

When using a tape recorded by the DSR-500WSL/500WSPL to transfer digital (video/audio/time code) signals at four times normal speed from the DSR-85/85P Digital Videocassette Recorder to the ES-7 EditStation for editing purposes, there must be about at least 40 seconds of recording on the tape before the IN point. To perform editing without problems, it is recommended **that you pre-record at least 40 seconds of color bar signals at the beginning of the tape.**

1) The ClipLink system is a video production system which uses the cassette memory function.

ClipLink Operation Flow

The following is a detailed description of how to use the ClipLink function during the video production process.

Example System Configuration

The following illustration shows the optimum system configuration for using the ClipLink function. ClipLink operation is possible even with a system containing existing analog equipment. However, note that a part of functions are disabled.

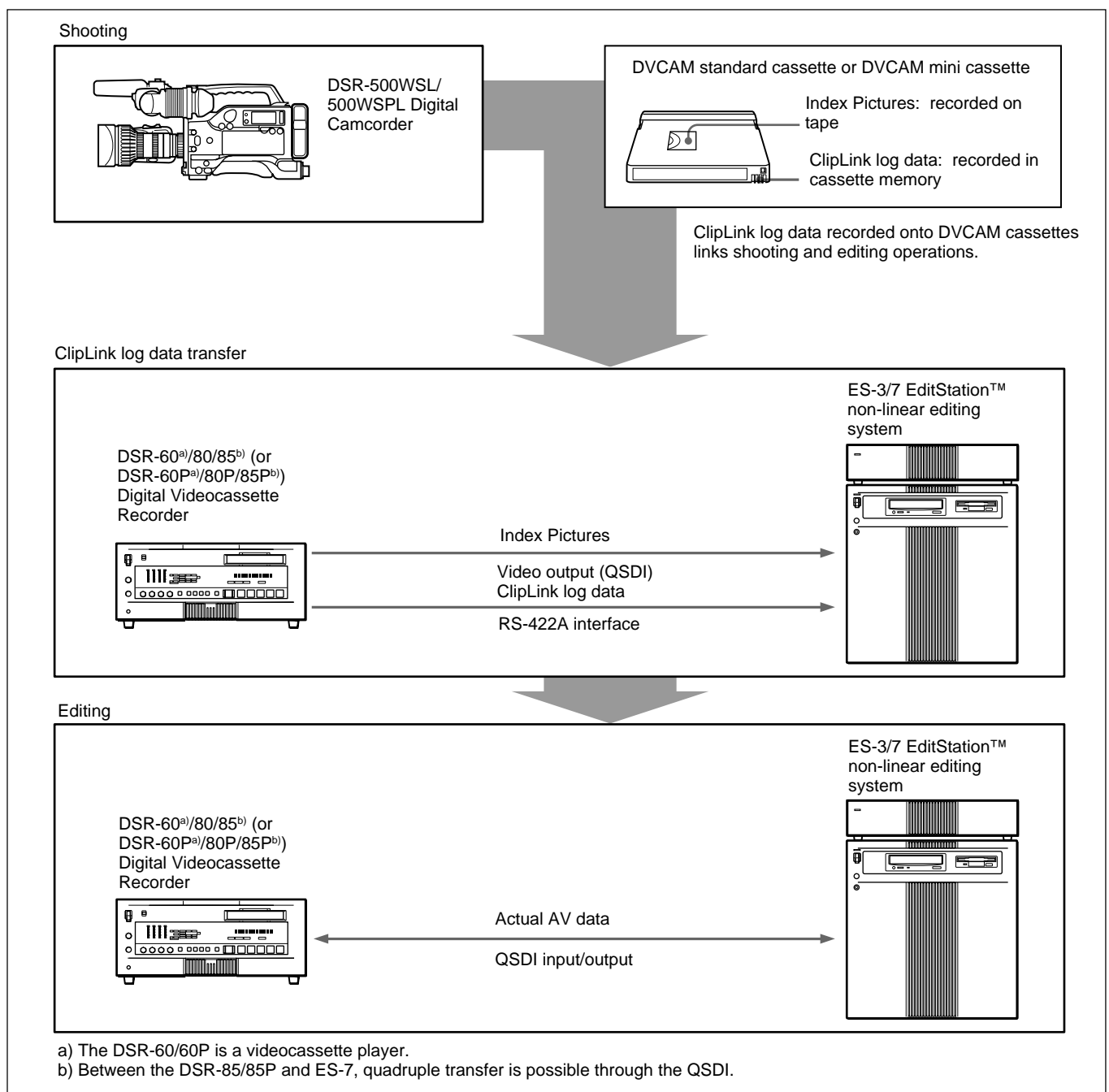

ClipLink Operation Flow

Data Generated When Shooting

The following describes the kinds of data that is generated when using the ClipLink function.

Index Pictures

When shooting, a single-frame image from the Mark IN point at the start of each scene is recorded as a still picture into the DSBK-301A's internal memory. These images are called "Index Pictures". When you finish shooting, the Index Pictures from all scenes are recorded onto the tape after the last scene.

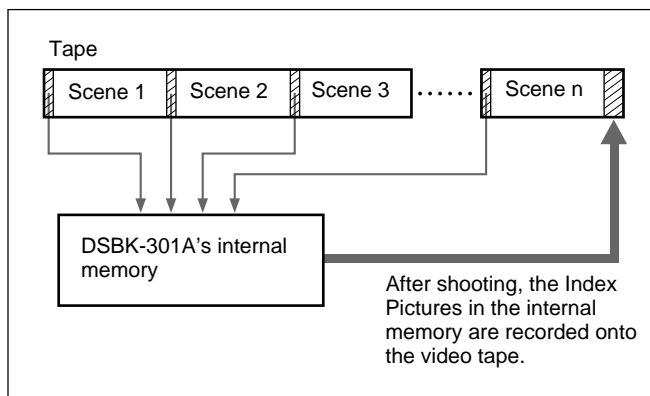

Up to 32 Index Pictures can be recorded onto the tape space normally occupied by one frame, as shown below.

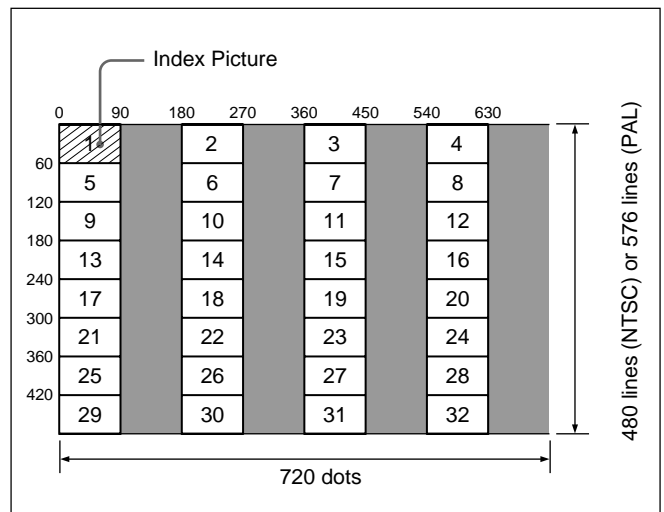

Seven frame spaces are reserved at the end of the last scene as a recording area for Index Pictures. (A cassette with 16 Kbits of cassette memory can record up to 198 Index Pictures, and a cassette with 4 Kbits of cassette memory can record up to 45 Index Pictures.)

ClipLink log data

ClipLink log data can be recorded automatically or manually into the cassette memory for use as a

convenient alternative to the conventional "shot list". ClipLink log data includes the following items.

ClipLink log data	Description
Reel number (cassette number)	Data (maximum length: 8 digits) consisting of alphanumeric characters and/or symbols (This is left blank at shipping.)
Scene number	A three-digit number from 001 to 198 (starts at 001 and is automatically incremented with each scene).
Take number	This cannot be changed (set to "1" at shipping).
OK/NG	Indicates the OK/NG status of a particular scene. (In the OK case, nothing is recorded.)
Mark IN/OUT point time codes	These are the time codes that indicate the Mark IN and Mark OUT points for each scene (HH:MM:SS). These time codes are recorded when the camcorder has been set to MARK mode. The frame digit is incremented at each Mark IN point and is decremented at each Mark OUT point. (For details, see "Time codes recorded for Mark IN/OUT points" on page 140.)
Cue point time code	This is the time code that indicates the cue points (valid up to the frame digit). This time code is recorded when the camcorder has been set to CUE mode. When in this mode, the time codes at the start and end of a recording (the Rec IN and Rec OUT time codes) are automatically recorded as Mark IN/OUT points.

How to record ClipLink log data

The following describes how to record the various ClipLink log data items.

OK/NG status

To designate a scene as “NG”, press the NG button on the camcorder while shooting the scene or at any time before you begin shooting the next scene.

All scenes that do not receive an “NG” designation are recorded as “OK” scenes.

(When you exit the VCR recording mode, changing the OK/NG status is no longer possible.)

Mark IN/OUT points time codes

This data is especially useful when shooting a video program for which a scenario has been created.

Set the camcorder to MARK mode before you start shooting. While shooting, each time you press the camcorder’s TAKE button, Mark IN and Mark OUT time codes are recorded alternately.

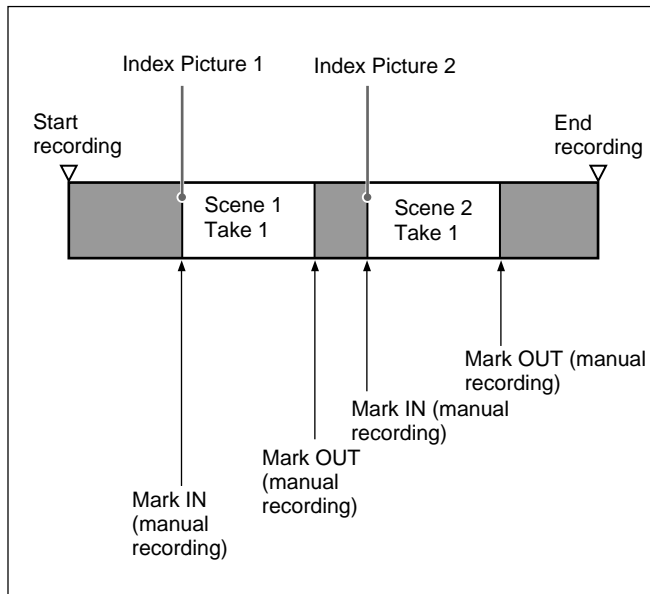

Cue point time codes

This type of data is especially useful when shooting scenes that may contain unexpected events, such as when shooting for sports coverage or documentaries. Set the camcorder to CUE mode before you start to record. While recording, each time you press the camera’s TAKE button, the current time code is recorded as a cue point time code.

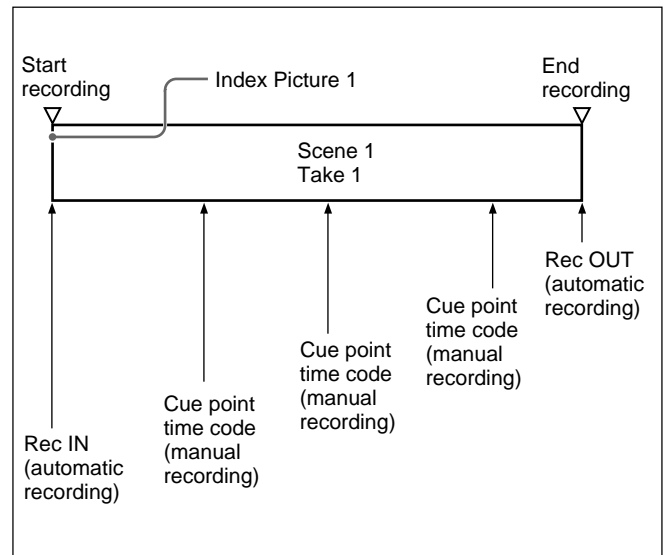

ClipLink Operation Flow

Time codes recorded for Mark IN/OUT points

There is a gap between actual time codes and Mark IN/OUT time codes recorded in the cassette memory, as shown in the figure below. The frame digit is incremented at each Mark IN point and is decremented at each Mark OUT point.

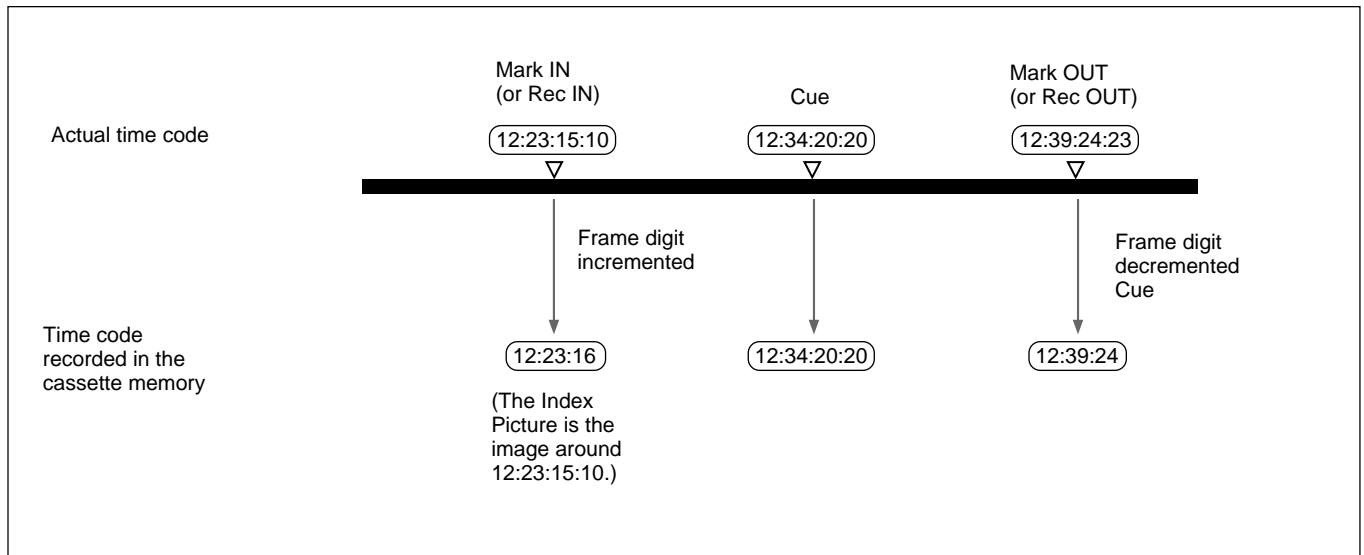

Recording capacity for Mark IN/OUT time codes and Cue point time codes

When in MARK mode, up to 198 pairs of Mark IN and Mark OUT points can be recorded (if using a cassette with 16 Kbits of cassette memory).

When in CUE mode, up to 396 time codes points (including all cue point time codes and all Mark (Rec) IN and Mark (Rec) OUT time codes) can be recorded (if using a cassette with 16 Kbits of cassette memory).

Aliasing

Distortion of the signal caused by overlap of the baseband signal and lower sideband signal when the signal is demodulated.

Aperture compensation

Electronic compensation for frequency response degradations caused to sampled high-frequency signals by the limited aperture of CCD image sensors.

Black balance adjustment

To balance the black levels of the R, G, and B channels of a video camera so that black has no color.

CCD

Charge-coupled device. A solid state imager used in most recent video cameras in place of a pickup tube. It converts input light levels into electrical charges, which are once stored and then output in the form of voltage variations.

Center marker

A cross that indicates the center of the image on the viewfinder screen.

Color conversion filter

An optical filter used with color video cameras to convert the color temperature of a light source.

Color temperature

The temperature in Kelvins (K) to represent the color of a light source.

Composite video signal

A composite video signal includes a video signal, burst signal, and sync signal.

Condensation

Condensation refers to tiny droplets of water that can appear in a device, such as in the tape transport system. When condensation occurs on a video head drum, the tape may stick to the drum, which can damage not only the tape but also the VCR unit.

DCC

Dynamic Contrast Control. A video camera containing a CCD circuit can handle a wide dynamic range of luminance.

Drum

See "Head drum".

Flare

Dark or colored flashes caused by signal overload through extreme light reflections of polished objects or very bright lights.

Flicker

Repeated change of brightness on the screen, which is caused by frequency difference between the camera's scanning and the variations in the lightning.

Gen-lock

Abbreviation of "generator lock". It refers to the synchronization of a VCR to a reference sync signal.

HAD

Hole-Accumulated Diode. A CCD sensor structure designed to suppress certain types of noise inherent CCDs. See also CCD.

Head drum

A metal cylinder to which a video head is attached. This drum is rotated at high speeds in synchronization with the sync signal during recording and playback.

Horizontal resolution

The capability of a CCD camera to preserve detail in the horizontal resolution.

Usually expressed as the number of vertical lines which can be distinguished in the reproduced image of a test chart.

i.LINK

i.LINK stands for IEEE1394-1995 standards and their revisions. It is applied to the DV connector through which DV signals can be transmitted with AV protocol.

IRE scale

The scale to determine video signal amplitudes devised by the Institute of Radio Engineers (IRE), an American organization now called the Institute of Electrical and Electronic Engineers (IEEE). The IRE scale includes a total of 140 units, with 100 up and 40 down from zero.

PCM audio

PCM stands for "Pulse Code Modulation." PCM audio means audio signals that have been processed by pulse code modulation. Each analog audio signal is converted into pulses that are generated in rapid succession, and each pulse is recorded as a digital signal having a value of 0 or 1.

Pedestal level

A black level which is the absolute black level of a video signal.

Return video

This refers to a video signal returned from the VCR to the camcorder or from the CCU to one camcorder in a multi-camera system, allowing the camcorder operator to monitor the image output from the camcorder or shot on other camcorders.

S/N

Signal-to-Noise ratio. The relation of the strength of the desired signal to the accompanying electronic interference, the noise. If S/N is high, sounds are reproduced with less noise and pictures are reproduced clearly without snow.

Search

The search function enables recorded images or time codes to be viewed while the tape is played back at various forward or reverse speeds, as a means of locating a particular scene in the taped program.

Standby-off mode

One of the stop modes. In this mode, head drum rotation is stopped and the tape tension is slackened. It is not possible to switch instantaneously from this mode to recording or playback mode. This mode is not harmful to the tape or heads.

Standby-on mode

One of the stop modes. In this mode, the head drum continues rotating and the tape remains wound onto the drum. This mode enables instantaneous switching to recording or playback mode. To prevent damage to the tape or heads, the device automatically switches from standby-on mode to standby-off mode after a certain period of time.

S video connectors

Input/output connectors for separate Y (luminance) and C (chroma) signals. This method eliminates interference between Y and C signals that can occur in conventional composite video signals to obtain a higher-resolution picture.

Sync

This refers to the sync (synchronization) signal. The sync signal is used as a reference signal for duplicating the scanning patterns recorded via a camcorder when playing back the recording on a monitor. The sync signal actually includes two signals: a horizontal sync signal and a vertical sync signal.

Time code

The time code is a tape position information signal that includes time and frame data that are recorded onto the tape when shooting so as to facilitate searching of editing points and recorded scenes when viewing or editing.

User bits

These are also referred to as "users' bits". The user bits are a 32-bit segment of the time code recording area. The user can select what to record in this segment and how to use the recorded data. For example, it can be used to record date information in addition to the time code data or ID numbers for tape reels or programs.

Video gain

Amount of amplification for video signals, expressed in decibels (dB).

White balance adjustment

In the light of a particular color temperature, to adjust the white levels of the R, G, and B channels of a color video camera so that any white object shot in that light is reproduced as a truly white image.

Zebra pattern

Striped patterns which appear in the viewfinder to indicate areas of the image where the video level is about 70 IRE (NTSC) or 70% (PAL). The DSR-500WSL/500WSPL can show areas where the video level is 100 IRE (NTSC) or 100% (PAL).

Sony  line <http://www.world.sony.com/>

Printed on recycled paper

Free Manuals Download Website

<http://myh66.com>

<http://usermanuals.us>

<http://www.somanuals.com>

<http://www.4manuals.cc>

<http://www.manual-lib.com>

<http://www.404manual.com>

<http://www.luxmanual.com>

<http://aubethermostatmanual.com>

Golf course search by state

<http://golfingnear.com>

Email search by domain

<http://emailbydomain.com>

Auto manuals search

<http://auto.somanuals.com>

TV manuals search

<http://tv.somanuals.com>