

# RYOBI®

## OPERATOR'S MANUAL BENCH GRINDER MODELS BGH615/BGH625/BGH825

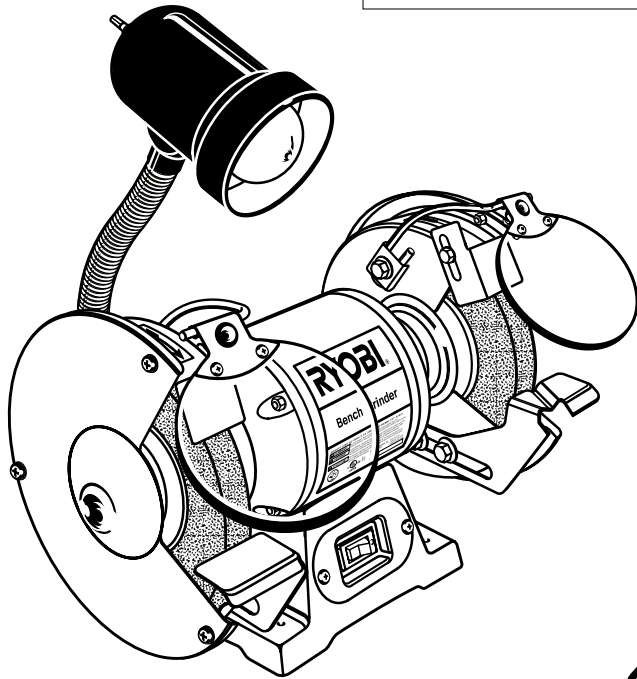

MODEL BGH615

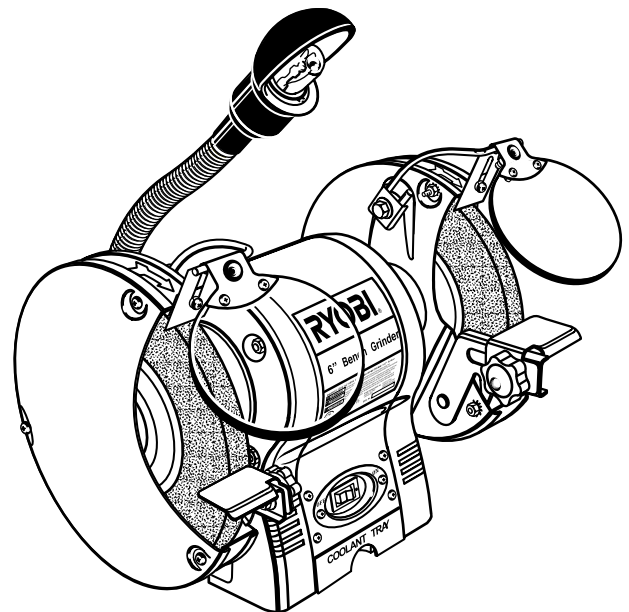

MODEL BGH625

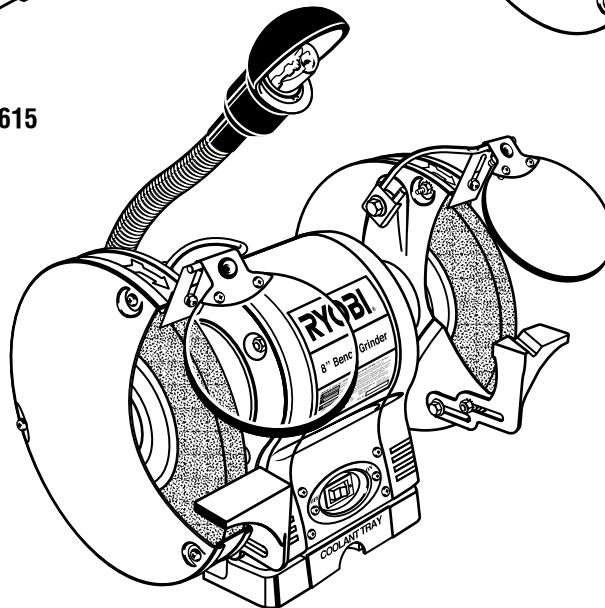

MODEL BGH825

### THANK YOU FOR BUYING A RYOBI BENCH GRINDER.

Your new Bench Grinder has been engineered and manufactured to Ryobi's high standards for dependability, ease of operation, and operator safety. Properly cared for, it will give you years of rugged, trouble-free performance.

**⚠ CAUTION:** Carefully read through this entire operator's manual before using your new machine.

Pay close attention to the Rules for Safe Operation, Warnings, and Cautions. If you use your grinder properly and only for what it is intended, you will enjoy years of safe, reliable service.

Please fill out and return the Warranty Registration Card so we can be of future service to you.

Thank you again for buying Ryobi tools.

## SAVE THIS MANUAL FOR FUTURE REFERENCE

# TABLE OF CONTENTS

■ Table of Contents.....	2
■ Product Specifications.....	2
■ Rules for Safe Operation .....	3-5
■ Electrical .....	6
■ Unpacking.....	6
■ Loose Parts List.....	7
■ Tools Needed.....	7
■ Features.....	8-10
■ Assembly .....	11-13
■ Operation.....	14-15
■ Maintenance .....	16
■ Parts Ordering / Service .....	20

## PRODUCT SPECIFICATIONS

	BGH615	BGH625	BGH825
Wheels:			
- Diameter	6 in. (152 mm)	6 in. (152 mm)	8 in. (203 mm)
- Thickness	3/4 in. (19 mm)	3/4 in. (19 mm)	1 in. (25.4 mm)
- Arbor Hole	1/2 in. (13 mm)	1/2 in. (13 mm)	5/8 in. (16 mm)
No Load Speed	3600 RPM	3600 RPM	3600 RPM
Rating	120 Volts, 60Hz-AC Only	120 Volts, 60Hz-AC Only	120 Volts, 60Hz-AC Only
Input	2.1 Amperes	2.1 Amperes	3.1 Amperes
Tool Weight	25 lbs. (11 kg)	22 lbs. (10 kg)	34 lbs. (15 kg.)



**Look for this symbol to point out important safety precautions. It means attention!!! Your safety is involved.**

# RULES FOR SAFE OPERATION

Safe operation of this power tool requires that you read and understand this operator's manual and all labels affixed to the tool. Safety is a combination of common sense, staying alert, and knowing how your bench grinder works.

## READ ALL INSTRUCTIONS

- **KNOW YOUR POWER TOOL.** Read the operator's manual carefully. Learn the applications and limitations as well as specific potential hazards related to this tool.
- **GUARD AGAINST ELECTRICAL SHOCK** by preventing body contact with grounded surfaces. For example: pipes, radiators, ranges, refrigerator enclosures.
- **KEEP GUARDS IN PLACE** and in working order. Never operate the tool with any guard or cover removed. Make sure all guards are operating properly before each use.
- **REMOVE ADJUSTING KEYS AND WRENCHES.** Form habit of checking to see keys and adjusting wrenches are removed from tool before turning it on.
- **KEEP THE WORK AREA CLEAN.** Cluttered work areas and work benches invite accidents.
- **AVOID DANGEROUS ENVIRONMENTS.** Do not use power tools near gasoline or other flammable liquids, in damp or wet locations or expose them to rain. Keep work area well lighted.
- **KEEP CHILDREN AND VISITORS AWAY.** All visitors should wear safety glasses and be kept a safe distance from work area.
- **MAKE WORKSHOP CHILDPROOF** with padlocks, master switches, or by removing starter keys.
- **DON'T FORCE THE TOOL.** It will do the job better and safer at the rate for which it was designed.
- **USE THE RIGHT TOOL.** Do not force the tool or attachment to do a job for which it was not designed.
- **USE THE PROPER EXTENSION CORD.** Make sure your extension cord is in good condition. When using an extension cord, be sure to use one heavy enough to carry the current your product will draw. An undersized cord will cause a drop in line voltage resulting in loss of power and overheating. A wire gage size (A.W.G.) of at least 16 is recommended for an extension cord 25 feet or less in length. If in doubt, use the next heavier gage. The smaller the gage number, the heavier the cord.
- **INSPECT EXTENSION CORDS PERIODICALLY** and replace if damaged.
- **WEAR PROPER APPAREL.** Do not wear loose clothing, neckties, or jewelry that can get caught in the tool's moving parts and cause personal injury. Nonslip footwear is recommended when working outdoors. Wear protective hair covering to contain long hair.
- **ALWAYS WEAR SAFETY GLASSES WITH SIDE SHIELDS.** Everyday eyeglasses have only impact-resistant lenses; they are NOT safety glasses.
- **PROTECT YOUR LUNGS.** Wear a face or dust mask if the cutting operation is dusty.

- **PROTECT YOUR HEARING.** Wear hearing protection during extended periods of operation.
- **DON'T ABUSE CORD.** Never carry tool by the cord or yank it to disconnect from receptacle. Keep cord from heat, oil, and sharp edges.
- **DO NOT OVERREACH.** Keep proper footing and balance at all times.
- **MAINTAIN TOOLS WITH CARE.** Keep tools sharp and clean for best and safest performance. Follow instructions for lubricating and changing accessories.
- **NEVER LEAVE TOOL RUNNING UNATTENDED. TURN POWER OFF.** Disconnect all tools when not in use, before servicing, or when changing attachments, wheels, etc.
- **AVOID ACCIDENTAL STARTING.** Be sure switch is off when plugging in.
- **USE RECOMMENDED ACCESSORIES.** The use of improper accessories may cause risk of injury.
- **USE ONLY GRINDING WHEELS** that comply with ANSI B7.1 and rated greater than 3600 RPM.
- **DO NOT** use wheels with incorrect size holes. NEVER use wheel washers or wheel screws that are defective or incorrect and NEVER touch grinding wheel or other moving parts.
- **NEVER STAND ON TOOL.** Serious injury could occur if the tool is tipped or if the wheel is unintentionally contacted.
- **DIRECTION OF FEED.** Be aware of wheel rotation direction; never grind without the workrest being properly set. NEVER grind more than one workpiece at a time.



**WARNING:** Wheel coasts after turn off.

- **CHECK DAMAGED PARTS.** Before further use of the tool, a guard or other part that is damaged should be carefully checked to determine that it will operate properly and perform its intended function. Check for alignment of moving parts, binding of moving parts, breakage of parts, mounting and any other conditions that may affect its operation. A guard or other part that is damaged must be properly repaired or replaced by an authorized service center to avoid risk of personal injury.
- **KEEP TOOL DRY, CLEAN, AND FREE FROM OIL AND GREASE.** Always use a clean cloth when cleaning. Never use brake fluids, gasoline, petroleum-based products, or any solvents to clean tool.
- **INSPECT TOOL CORDS AND EXTENSION CORDS PERIODICALLY** and, if damaged, have repaired by a qualified service technician. Stay constantly aware of cord location and keep it well away from the rotating wheel.
- **NEVER USE IN AN EXPLOSIVE ATMOSPHERE.** Normal sparking of the motor or sparking from grinding metal could ignite fumes.

# RULES FOR SAFE OPERATION

- **USE OUTDOOR EXTENSION CORDS.** Use only extension cords with approved ground connection that are intended for use outdoors and so marked.
- **NEVER** reach to pick up a workpiece, a piece of scrap, or anything else that is in or near the grinding path of the wheel.
- **AVOID AWKWARD OPERATIONS AND HAND POSITIONS** where a sudden slip could cause your hand to move into the wheel. **ALWAYS** make sure you have good balance.
- **NEVER** stand or have any part of your body in line with the path of the wheel.
- **DO NOT USE TOOL IF SWITCH DOES NOT TURN IT ON AND OFF.** Have defective switches replaced by an authorized service center.
- **DO NOT TURN THE MOTOR SWITCH ON AND OFF RAPIDLY.** This could cause the wheel to loosen and could create a hazard. Should this ever occur, stand clear and allow the wheel to come to a complete stop. Disconnect your grinder from the power supply and securely retighten the wheel nut.
- **RISK OF INJURY DUE TO ACCIDENTAL STARTING.** Do not use in an area where children may be present.
- **NEVER START THE GRINDER** when the wheel is in contact with the workpiece.
- **SECURE WORK.** Always hold workpiece firmly against the work rest.
- **DO NOT USE THE BENCH GRINDER** if the flange nut or clamp nut is missing or if the spindle shaft is bent.
- **FREQUENTLY** clean grinding dust from beneath grinder.
- **DO NOT OPERATE THIS TOOL WHILE UNDER THE INFLUENCE OF DRUGS, ALCOHOL, OR ANY MEDICATION.**
- **ALWAYS STAY ALERT.** Do not allow familiarity (gained from frequent use of your grinder) to cause a careless mistake. **ALWAYS REMEMBER** that a careless fraction of a second is sufficient to inflict severe injury.
- **STAY ALERT AND EXERCISE CONTROL.** Watch what you are doing and use common sense. Do *not* operate tool when you are tired. Do *not* rush.
- **SAVE THESE INSTRUCTIONS.** Refer to them frequently and use them to instruct other users. If you loan someone this tool, loan them these instructions also.

## **WARNING:**

When servicing use only identical Ryobi replacement parts. Use of any other parts may create a hazard or cause product damage.

- **USE ONLY FLANGES** furnished with this bench grinder.
- **IF ANY PART OF THIS GRINDER IS MISSING** or should break, bend, or fail in any way, or should any electrical component fail to perform properly, shut off the power switch, remove the machine plug from the power source and have damaged, missing, or failed parts replaced before resuming operation.
- **MAKE SURE THE GRINDER IS SECURELY MOUNTED** as described in the operating instructions before connecting the tool to a power supply.
- **DO NOT OVERTIGHTEN THE WHEEL NUT.** Excessive tightening can cause the wheel to crack during operation.
- **INSPECT GRINDING WHEEL** for visible defects. Check the wheel for fissures and cracks, and test for normal operation prior to use.
- **ADJUST** distance between wheel and work rest to maintain 1/16 in. or less separation as the diameter of the wheel decreases with use. The value of separation used in the marking is to be the separation recommended by the manufacturer but shall not be more than 1/8 in.
- **ALWAYS EASE THE WORKPIECE AGAINST THE ABRASIVE WHEEL** when starting to grind. A harsh impact can break the wheel. Use light pressure when starting to grind; too much pressure on a cold wheel can cause the wheel to crack.

## **WARNING:**

Some dust created by power sanding, sawing, grinding, drilling, and other construction activities contains chemicals known to cause cancer, birth defects or other reproductive harm. Some examples of these chemicals are:

- lead from lead-based paints,
- crystalline silica from bricks and cement and other masonry products, and
- arsenic and chromium from chemically-treated lumber.

Your risk from these exposures varies, depending on how often you do this type of work. To reduce your exposure to these chemicals: work in a well ventilated area, and work with approved safety equipment, such as those dust masks that are specially designed to filter out microscopic particles.



# RULES FOR SAFE OPERATION

The purpose of safety symbols is to attract your attention to possible dangers. The safety symbols, and the explanations with them, deserve your careful attention and understanding. The safety warnings do not by themselves eliminate any danger. The instructions or warnings they give are not substitutes for proper accident prevention measures.

## SYMBOL

## MEANING



### SAFETY ALERT SYMBOL:

Indicates danger, warning, or caution. May be used in conjunction with other symbols or pictographs.



**DANGER:** Failure to obey a safety warning will result in serious injury to yourself or to others. Always follow the safety precautions to reduce the risk of fire, electric shock and personal injury.



**WARNING:** Failure to obey a safety warning can result in serious injury to yourself or to others. Always follow the safety precautions to reduce the risk of fire, electric shock and personal injury.



**CAUTION:** Failure to obey a safety warning may result in property damage or personal injury to yourself or to others. Always follow the safety precautions to reduce the risk of fire, electric shock and personal injury.

## NOTE:

Advises you of information or instructions vital to the operation or maintenance of the equipment.

## IMPORTANT

Servicing requires extreme care and knowledge and should be performed only by a qualified service technician. For service we suggest you return the tool to your nearest **RYOBI AUTHORIZED SERVICE CENTER** for repair. When servicing, use only identical Ryobi replacement parts.



## WARNING:

Do not attempt to operate this tool until you have read thoroughly and understand completely all instructions, safety rules, etc. contained in this manual. Failure to comply can result in accidents involving fire, electric shock, or serious personal injury. Save this operator's manual and review frequently for continuing safe operation and instructing others who may use this tool.



The operation of any grinder can result in foreign objects being thrown into your eyes, which can result in severe eye damage. Before beginning power tool operation, always wear safety goggles or safety glasses with side shields and a full face shield when needed. We recommend Wide Vision Safety Mask for use over eyeglasses or standard safety glasses with side shields.

# ELECTRICAL

## EXTENSION CORDS

Use only 3-wire extension cords that have 3-prong grounding plugs and 3-pole receptacles that accept the tool's plug. When using a power tool at a considerable distance from the power source, use an extension cord heavy enough to carry the current that the tool will draw. An undersized extension cord will cause a drop in line voltage, resulting in a loss of power and causing the motor to overheat. Use the chart provided below to determine the minimum wire size required in an extension cord. Only round jacketed cords listed by Underwriter's Laboratories (UL) should be used.

Length of Extension Cord	Wire Size (A.W.G.)
Up to 25 feet	16
26-50 feet	16
51-100 feet	16

When working with the tool outdoors, use an extension cord that is designed for outside use. This is indicated by the letters WA on the cord's jacket.

Before using an extension cord, inspect it for loose or exposed wires and cut or worn insulation.

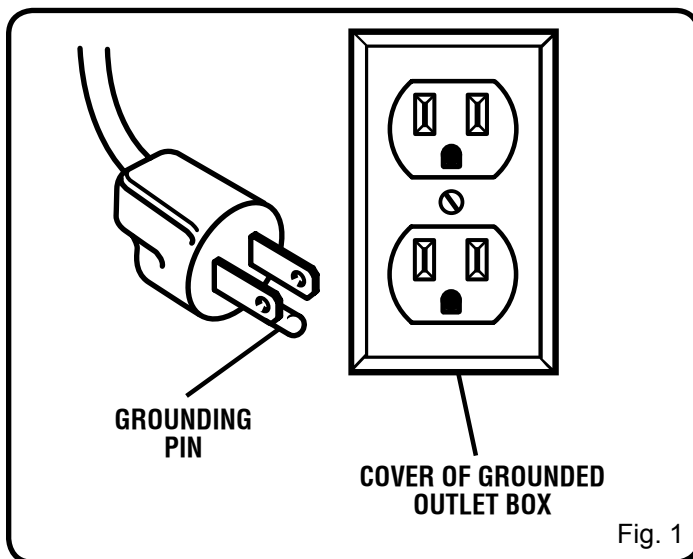

## ELECTRICAL CONNECTION

Your Ryobi Bench Grinder is powered by a precision built electric motor. It should be connected to a power supply that is 120 volts, 60Hz, AC only (normal household current). Do not operate this tool on direct current (DC). A substantial voltage drop will cause a loss of power and the motor will overheat. If the machine does not operate when plugged into an outlet, double check the power supply.

### **⚠ CAUTION:**

Keep the cord away from the grinding area and position the cord so that it will not be caught on material, tools, or other objects.

## GROUNDING INSTRUCTIONS

In the event of a malfunction or breakdown, grounding provides a path of least resistance for electric current to reduce the risk of electric shock. This tool is equipped with an electric cord having an equipment-grounding conductor and a grounding plug. The plug must be plugged into a matching outlet that is properly installed and grounded in accordance with all local codes and ordinances.

Do not modify the plug provided. If it will not fit the outlet, have the proper outlet installed by a qualified electrician. Improper connection of the equipment-grounding conductor can result in electrical shock. The conductor with insulation having an outer surface that is green with or without yellow stripes is the equipment-grounding conductor. If repair or replacement of the electric cord or plug is necessary, do not connect the equipment-grounding conductor to a live terminal.

Check with a qualified electrician or service personnel if the grounding instructions are not completely understood, or if in doubt as to whether the tool is properly grounded.

Repair or replace a damaged or worn cord immediately.

This tool is intended for use on a circuit that has an outlet like the one shown in figure 1. It also has a grounding pin like the one shown.

# UNPACKING

- Carefully remove all parts from the shipping carton.
- Lift the bench grinder from the carton and place it on a level work surface.
- Do not discard the packing materials until you have carefully inspected the machine, identified all loose parts, and satisfactorily operated your bench grinder.
- Examine all parts to make sure no breakage or damage has occurred during shipping.
- If all parts have been included, proceed to assembly.
- If any parts are damaged or missing, do not attempt to plug in this tool or turn it on until the damaged or missing parts are obtained and installed correctly.
- Contact your nearest Ryobi dealer or call 1-800-525-2579 in the United States or 1-800-265-6778 in Canada for assistance if any parts are missing or damaged.

### **⚠ WARNING:**

If any parts are missing do not operate this machine until the missing parts are replaced. Failure to do so could result in possible serious injury.

# LOOSE PARTS LIST

## LOOSE PARTS LIST – BGH615

The following items are included with your Bench Grinder:

- Shield Rods – one left, one right ..... 2
- Shield Rod Brackets with Hardware..... 2
- Safety Shields..... 2
- Spark Deflectors – one left, one right..... 2
- Work Rests – one left, one right ..... 2

- Washers (6 mm)..... 2
- Washers (8 mm)..... 6
- Hex Bolts (6 mm x 6) ..... 2
- Hex Bolts (8 mm x 8) ..... 4
- Hex Bolts (8 mm x 14) ..... 2
- Operator's Manual

## LOOSE PARTS LIST – BGH625

The following items are included with your Bench Grinder:

- Shield Rods – one left, one right ..... 2
- Shield Rod Brackets with Hardware..... 2
- Safety Shields ..... 2
- Spark Deflectors..... 2
- Work Rests – one left, one right ..... 2
- Lock Washers (5 mm)..... 2
- Washers (5 mm)..... 2

- Washers (8 mm)..... 2
- Phillips Screws (5 mm x 8) ..... 2
- Hex Bolts (8 mm x 14) ..... 2
- Adjustment Knobs..... 2
- Hex Nuts (5 mm)..... 2
- Washers (5 mm)..... 2
- Operator's Manual

## LOOSE PARTS LIST – BGH825

The following items are included with your Bench Grinder:

- Shield Rods – one left, one right ..... 2
- Shield Rod Brackets with Hardware..... 2
- Safety Shields..... 2
- Spark Deflectors..... 2
- Work Rests – one left, one right ..... 2
- Lock Washers (5 mm)..... 2

- Washers (5 mm)..... 2
- Washers (8 mm)..... 2
- Phillips Screws (5 mm x 8) ..... 2
- Hex Bolts (8 mm x 14) ..... 2
- Hex Bolts (5 mm x 10) ..... 2
- Operator's Manual

# TOOLS NEEDED

The following tools (not included) are needed for assembly and alignment:

**7 MM, 10 MM, AND 12 MM  
COMBINATION WRENCH**

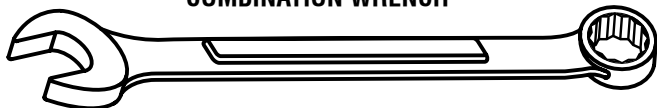

**PHILLIPS SCREWDRIVER**

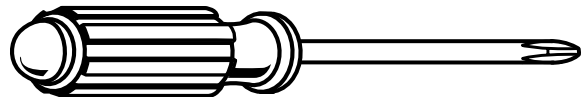

**ADJUSTABLE WRENCH**

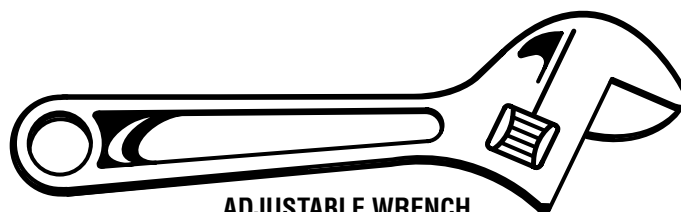

Fig. 2

# FEATURES – BGH615

## KNOW YOUR BENCH GRINDER

See Figure 3a.

Before attempting to use your new tool, familiarize yourself with all operating features and safety requirements. Carefully read this operator's manual before using your grinder.

## ON/OFF SWITCH

Your BGH615 Bench Grinder features a front access On/Off switch for convenience and safety.

## MOTOR

Powered by a precision-built electric induction motor, your bench grinder has sufficient power to handle tough grinding jobs.

## GRINDING WHEEL

Equipped with course and fine grinding wheels to suit most applications.

**Note:** New wheels sometimes require dressing to true up the face of the wheel.

## SAFETY SHIELD AND SPARK DEFLECTOR

The safety shields and spark deflectors are adjustable for operator convenience. Operating the grinder without these features attached could result in serious injury. Do not grind with the safety shield raised; always wear safety glasses for personal protection.

## WORK REST

The work rests are independently adjustable to compensate for wheel wear. Before grinding, make certain the work rests are adjusted properly. Generally the object being ground is done slightly above center of the grinding wheel.

Adjust the distance between the wheel and the work rest to maintain 1/16 in. or less separation as the diameter of the wheel decreases with use.

## WORKLIGHT

Your BGH615 Bench Grinder comes equipped with a permanently mounted worklight that lights the work area for safer, more accurate grinding and sharpening. (Requires a 40 watt bulb – not included.)

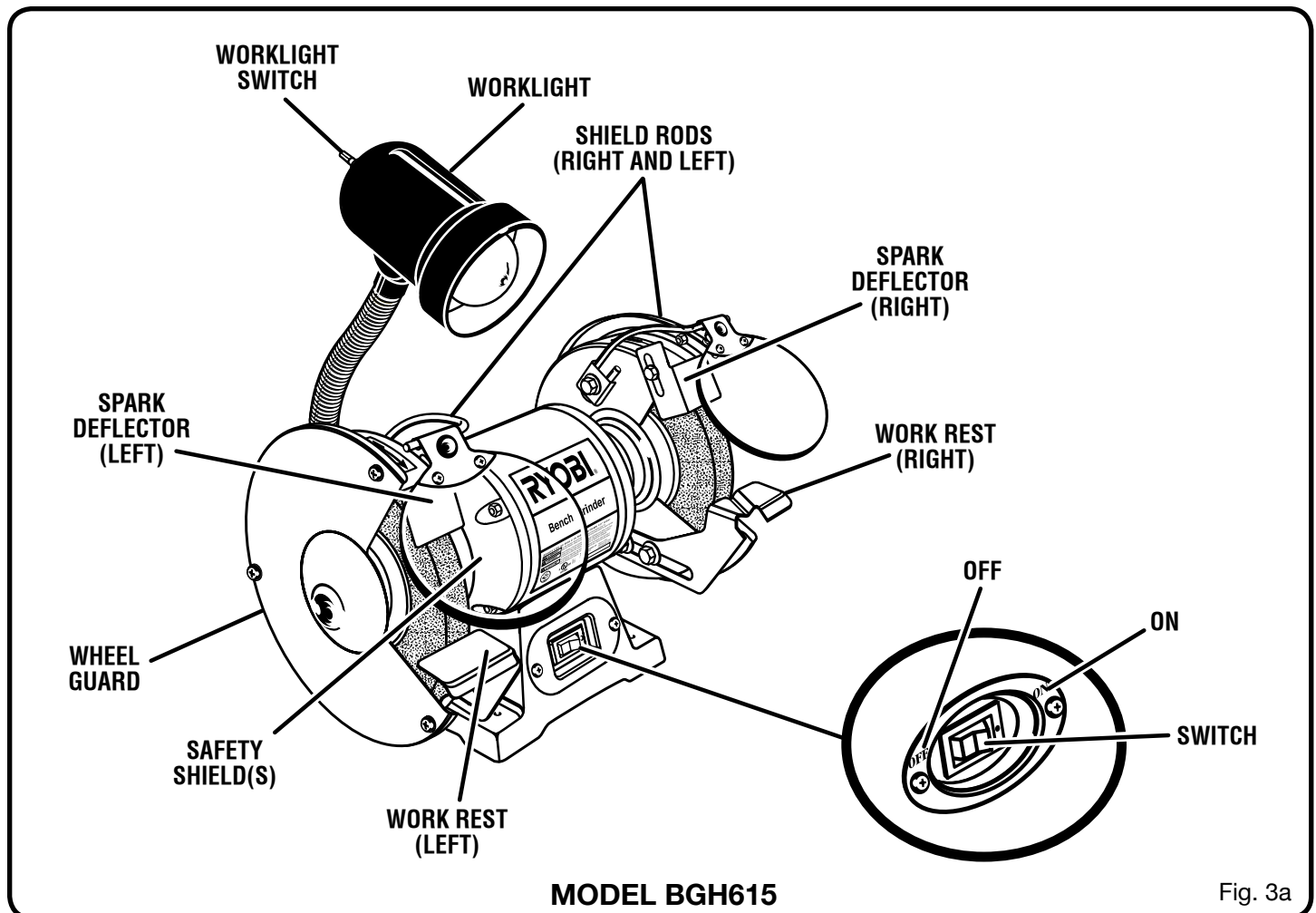

Fig. 3a



# FEATURES – BGH625

## KNOW YOUR BENCH GRINDER

See Figure 3b.

Before attempting to use your new tool, familiarize yourself with all operating features and safety requirements. Carefully read this operator's manual before using your grinder.

## ON/OFF SWITCH

Your BGH625 Bench Grinder features a front access On/Off switch for convenience and safety.

## MOTOR

Powered by a precision-built electric induction motor, your bench grinder has sufficient power to handle tough grinding jobs.

## GRINDING WHEEL

Equipped with coarse and fine grinding wheels to suit most applications.

**Note:** New wheels sometimes require dressing to true up the face of the wheel.

## SAFETY SHIELD AND SPARK DEFLECTOR

The safety shields and spark deflectors are adjustable for operator convenience. Operating the grinder without these features attached could result in serious injury. Do not grind with the safety shield raised; always wear safety glasses for personal protection.

## WORK REST

The work rests are independently adjustable to compensate for wheel wear. Before grinding, make certain the work rests are adjusted properly. Generally the object being ground is done slightly above center of the grinding wheel.

Adjust the distance between the wheel and the work rest to maintain 1/16 in. or less separation as the diameter of the wheel decreases with use.

## WHEEL DRESSING TOOL

A buildup of metals, dirt, rust, etc. will become embedded in the grinding wheel as it wears. Using the Wheel Dressing Tool to clean the wheel of these ground-in particles will help improve the grinder's performance.

## AUTO-ON WORKLIGHT

Your BGH625 Bench Grinder comes equipped with a permanently mounted worklight that automatically lights the work area for safer, more accurate grinding and sharpening.

## COOLANT TRAY

When grinding, metal objects become heated quickly. It is important to keep moving the object back and forth across the grinding wheel and to cool the object frequently using the grinder's Coolant Tray.

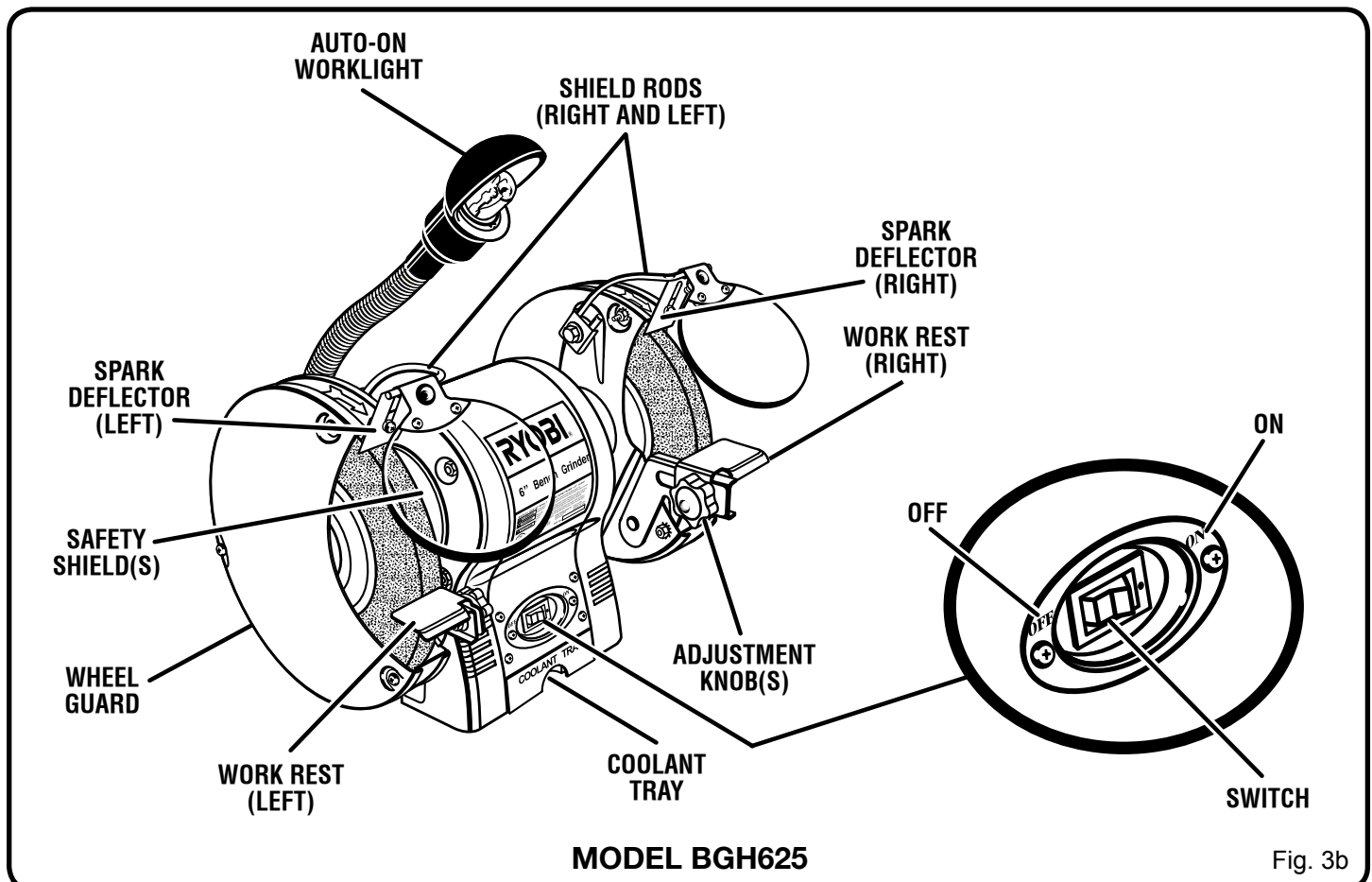

Fig. 3b

# FEATURES – BGH825

## KNOW YOUR BENCH GRINDER

See Figure 3c.

Before attempting to use your new tool, familiarize yourself with all operating features and safety requirements. Carefully read this operator's manual before using your grinder.

## ON/OFF SWITCH

Your BGH825 Bench Grinder features a front access On/Off switch for convenience and safety.

## MOTOR

Powered by a precision-built electric induction motor, your bench grinder has sufficient power to handle tough grinding jobs.

## GRINDING WHEEL

Equipped with coarse and fine grinding wheels to suit most applications.

**Note:** New wheels sometimes require dressing to true up the face of the wheel.

## SAFETY SHIELD AND SPARK DEFLECTOR

The safety shields and spark deflectors are adjustable for operator convenience. Operating the grinder without these features attached could result in serious injury. Do not grind with the safety shield raised; always wear safety glasses for personal protection.

## WORK REST

The work rests are independently adjustable to compensate for wheel wear. Before grinding, make certain the work rests are adjusted properly. Generally the object being ground is done slightly above center of the grinding wheel.

Adjust the distance between the wheel and the work rest to maintain 1/16 in. or less separation as the diameter of the wheel decreases with use.

## WHEEL DRESSING TOOL

A buildup of metals, dirt, rust, etc. will become embedded in the grinding wheel as it wears. Using the Wheel Dressing Tool to clean the wheel of these ground-in particles will help improve the grinder's performance.

## AUTO-ON WORKLIGHT

Your BGH825 Bench Grinder comes equipped with a permanently mounted worklight that automatically lights the work area for safer, more accurate grinding and sharpening.

## COOLANT TRAY

When grinding, metal objects become heated quickly. It is important to keep moving the object back and forth across the grinding wheel and to cool the object frequently using the grinder's Coolant Tray.

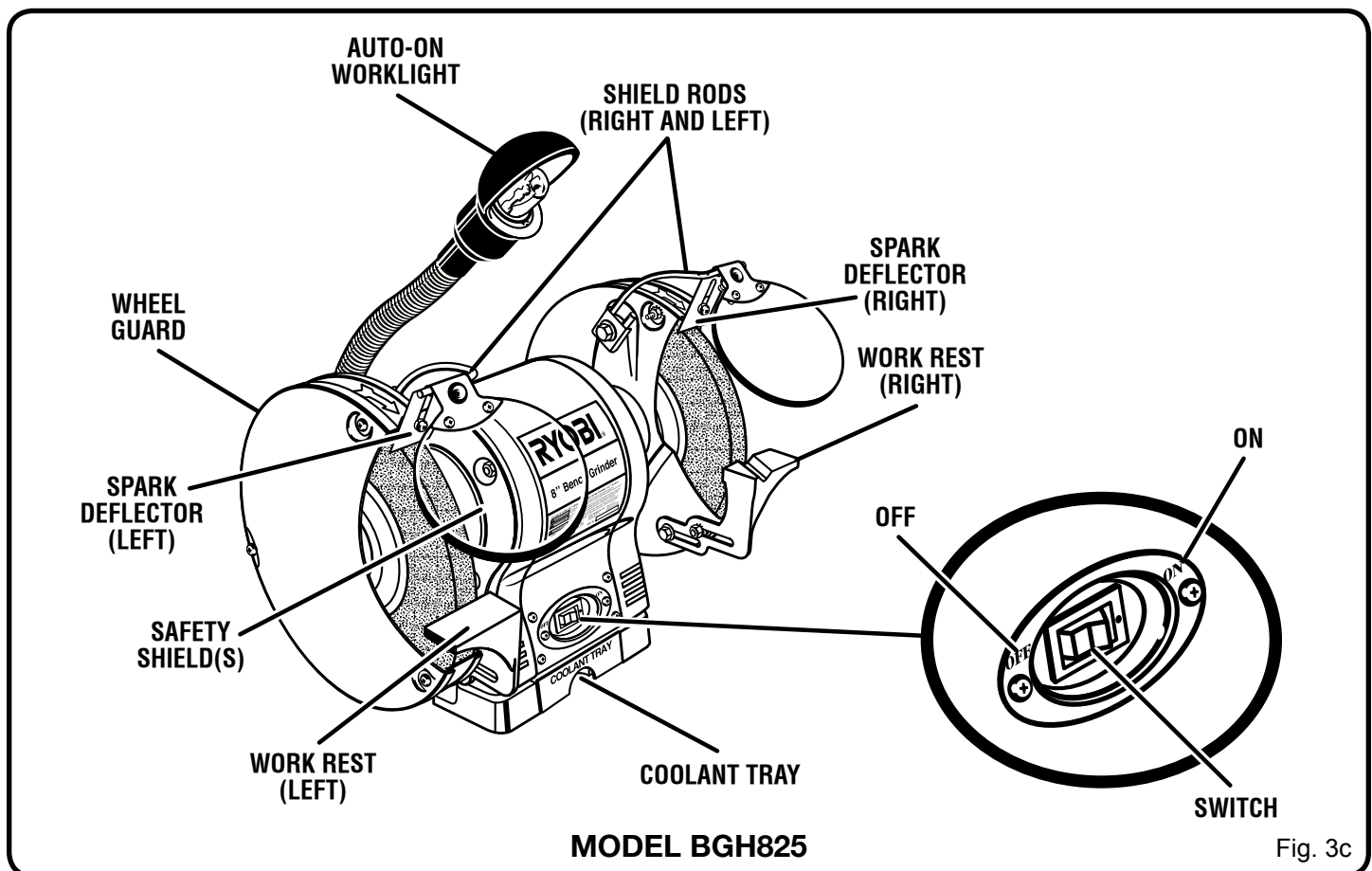

# ASSEMBLY

## **⚠ WARNING:**

Always disconnect the bench grinder from the power source before performing any assembly or adjustment. Failure to do so could result in accidental starting resulting in possible serious personal injury.

### **SPARK DEFLECTOR – BGH615**

See Figure 4a.

Using two 6 mm hex bolts and washers, attach the spark deflector to the inside of the wheel guard.

Adjust the spark deflectors to within 1/16 in. of the grinding wheel. Tighten the hex bolts securely.

### **SPARK DEFLECTOR – BGH625 AND BGH825**

See Figures 4b and 4c.

Using the two phillips head screws, washers, and lock washers, attach the spark deflector to the top of the wheel guard.

Adjust the spark deflectors to within 1/16 in. of the grinding wheel. Tighten the hex bolts securely.

## **⚠ WARNING:**

Always spin the wheel by hand before turning on the grinder to make sure the spark deflector doesn't hit the grinding wheel.

## **⚠ WARNING:**

Always make sure your bench grinder is securely mounted to a workbench or an approved workstand. Failure to do so could result in an accident resulting in possible serious personal injury.

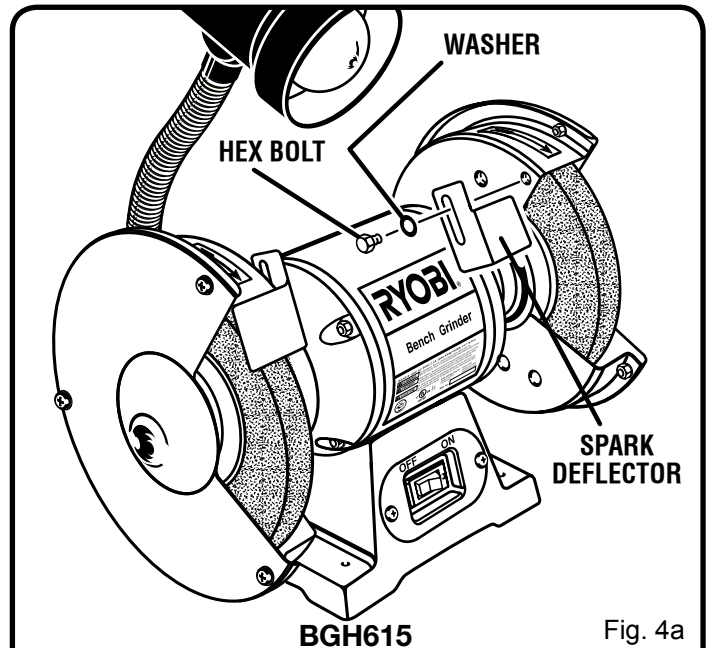

Fig. 4a

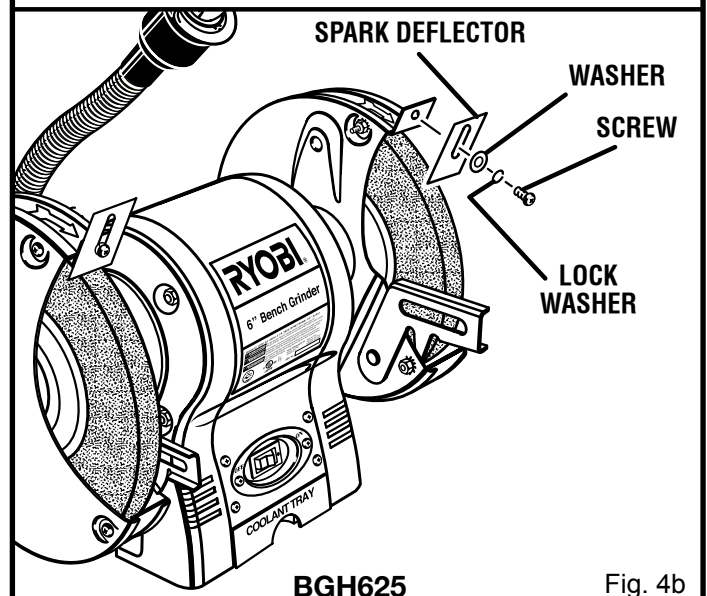

Fig. 4b

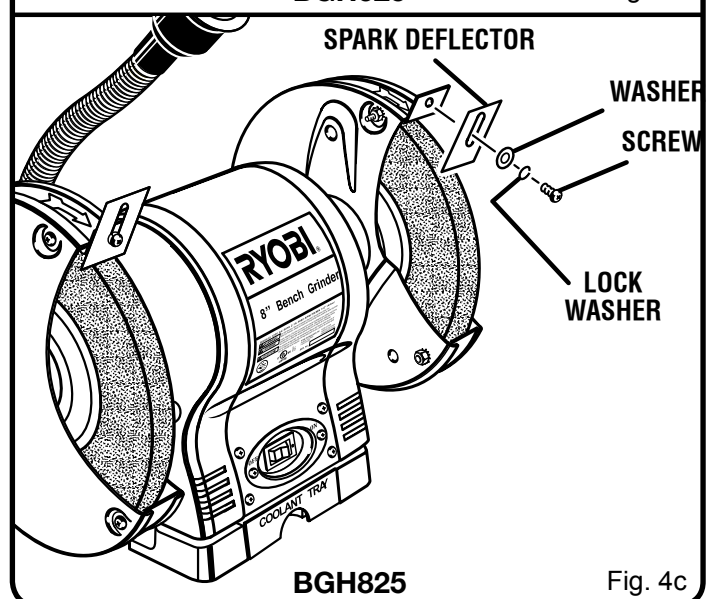

Fig. 4c

# ASSEMBLY

## SHIELD BRACKET ASSEMBLY

See Figure 5.

**Note:** The hardware used for assembling the safety shields to the shield brackets has been preassembled and prepackaged.

Remove the two phillips head screws, washers, and hex nuts from the shield bracket. Fit the shield bracket to the top of the safety shield. Reattach the screws, washers, and hex nuts taking care not to tighten the screws so tight as to crack the plastic. Repeat for the other shield bracket and safety shield.

### **WARNING:**

To prevent personal injury, never operate the bench grinder unless the safety shields and spark deflectors are properly installed and in place.

## MOUNTING SAFETY SHIELDS

See Figures 6a - 6c.

Mount the left and right shield rods to the inside of the wheel guards using the clamp brackets, hex bolts (8 mm x 14 mm), and washers (8 mm).

Locate your grinder in figures 6a, 6b, or 6c. Use the illustration as a guide to determine which shield rod is mounted on the left and which shield rod is mounted on the right of the grinder.

Once shield rods are firmly in place, slide the shield bracket onto the shield rod. Tighten the carriage bolt leaving it loose enough to allow the safety shield to be raised and lowered easily.

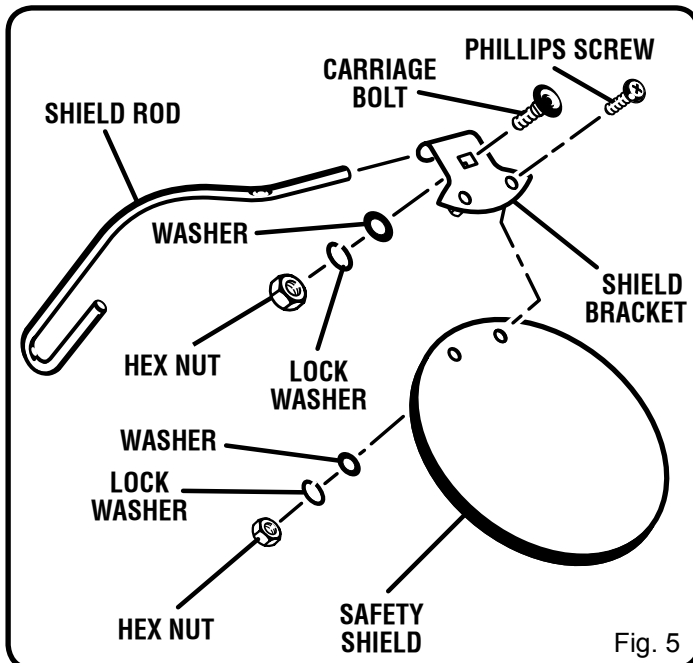

Fig. 5

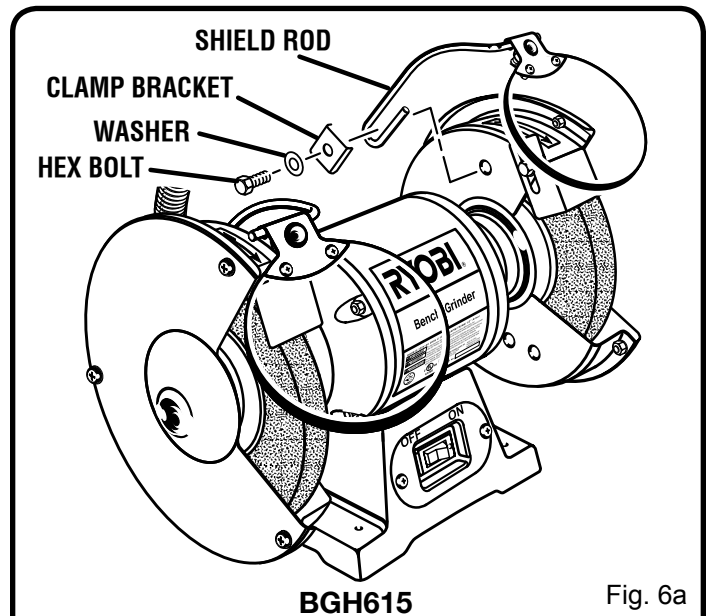

Fig. 6a

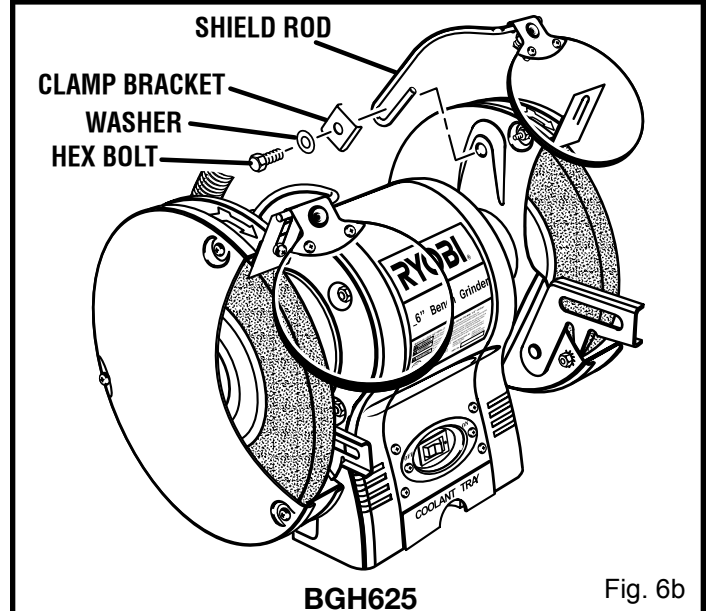

Fig. 6b

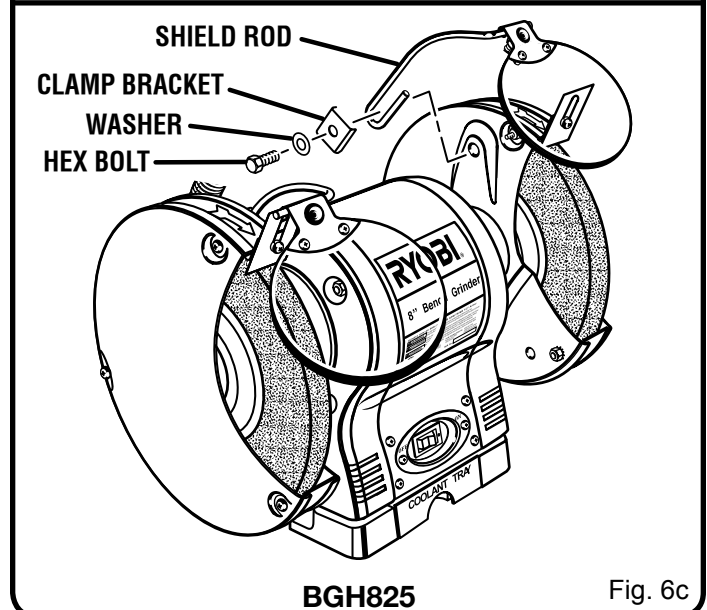

Fig. 6c



# ASSEMBLY

## WORK REST – BGH615

See Figure 7a.

Mount the work rests to the inside of each wheel guard using two hex bolts (8 mm x 8) and two washers (8 mm) on each side.

Before tightening the bolts, adjust the gap between the grinding wheel and the work rest to a maximum of 1/16 in. Tighten securely.

## WORK REST – BGH625

See Figure 7b.

Mount the work rests to the work rest bracket using the knob, washer, and one hex nut.

Before tightening the bolts, adjust the gap between the grinding wheel and the work rest to a maximum of 1/16 in. Tighten securely.

## WORK REST – BGH825

See Figure 7c.

Before attempting to mount the work rest, remove the hex nut and star washer from the phillips screw. See Figure 7c. Place the work rest over the phillips screw before replacing the hex nut and star washer. Using the hex bolt (5 mm x 10 mm) and washer (5 mm), secure the work rest against the inside of the wheel guard.

Before tightening the bolts, adjust the gap between the grinding wheel and the work rest to a maximum of 1/16 in. Tighten securely.

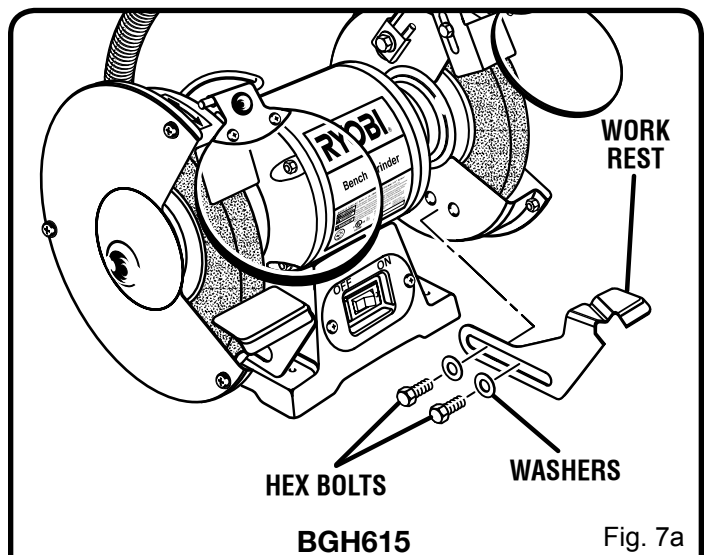

Fig. 7a

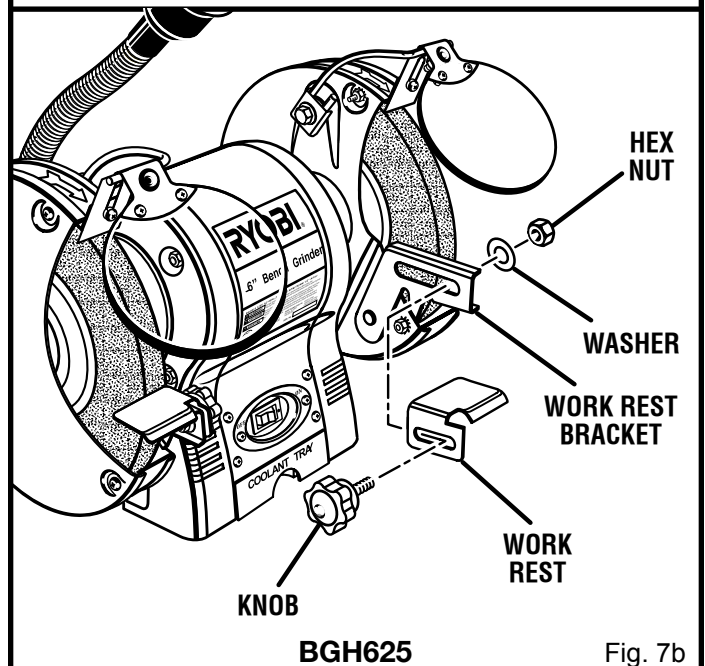

Fig. 7b

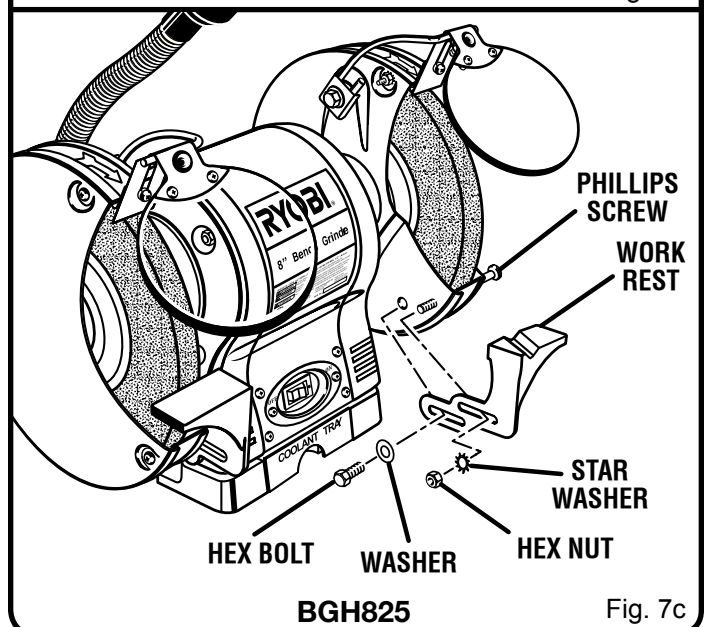

Fig. 7c

# OPERATION

## BASIC OPERATION

### **⚠ WARNING:**

Always wear safety goggles or safety glasses with side shields during power tool operation or when blowing dust. If operation is dusty, wear a dust mask.

To be efficient and work as designed, your tools should be kept sharp. Dull tools can and will cause accidents.

Bench Grinders are ideal for sharpening tools such as chisels, planer blades, scissors, etc., and for removing rust or corrosion.

### **⚠ WARNING:**

Never sharpen or grind anything made of aluminum.

Grinders remove material rapidly so pressure is the key to efficient grinding.

The proper way to sharpen a tool and avoid overheating is:

- Keep the object in constant motion, moving it at an even pace.
- Never force a tool against the grinding wheel.
- Keep the tool cool by using either a cooling tray or a pan of water.
- The grinding wheel should rotate “into” the object being sharpened.

**Note:** Excessive pressure may damage the tool, cause the motor to overheat, and prematurely wear down the grinding wheel.

### **⚠ WARNING:**

Excessive pressure on a cold wheel may cause the wheel to crack.

The following recommendations will help you sharpen specific tools:

### **TWIST DRILL BITS**

See Figure 8.

Drill bits are best sharpened on a sharpening jig (available at most hardware stores). Begin on one side of the point at the existing angle, then twist the bit while maintaining contact with the grinding surface. Sharpen only the tip.

This technique requires considerable practice, so take your time and make a few “dry runs” first with the grinder off. Be sure to maintain the original cutting edge angle as this is important to the efficiency of your bits. One work rest has a V-groove (models BGH615 and BGH825 only) angled to fit most drill bits.

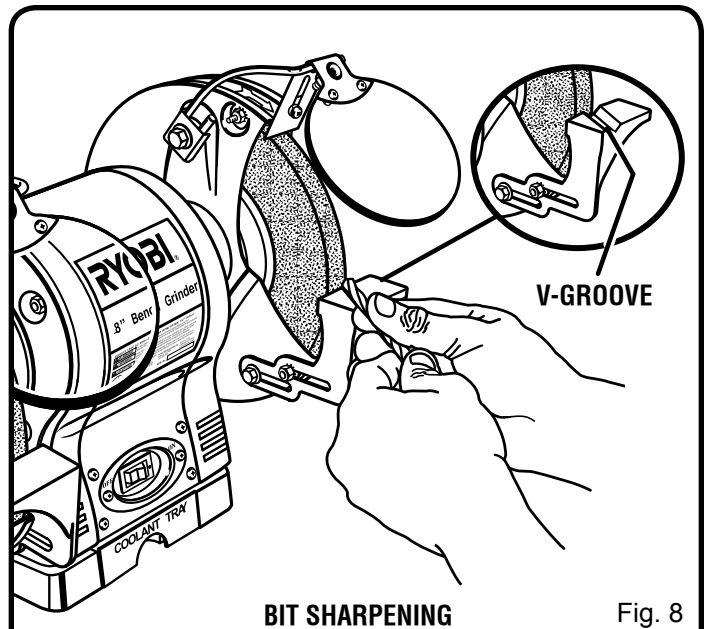

Fig. 8

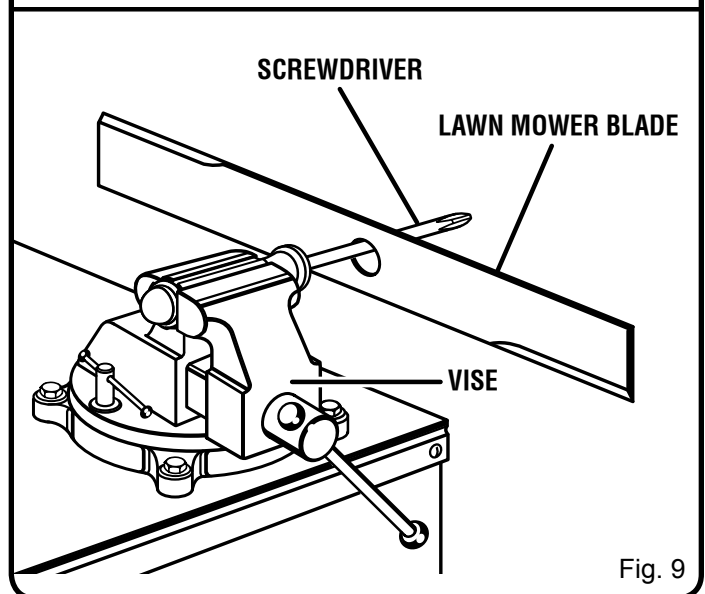

Fig. 9

### **LAWN MOWER BLADES**

See Figure 9.

Lawn mower blades are usually sharpened on only one edge and dressed up slightly on the other. Perform this sharpening process on both cutting ends of the blade. After sharpening, be sure to balance the blade by removing additional material.

### **⚠ CAUTION:**

An unbalanced lawn mower blade may cause excessive vibration which will damage the lawn mower.

# OPERATION

## CHISELS AND SCREWDRIVER BLADES

See Figure 10.

When sharpening chisels and screwdrivers, work rest should support the chisel at the correct angle against the wheel.

### **⚠ WARNING:**

Always disconnect the bench grinder from the power source before performing any assembly or adjustment. Failure to do so could result in accidental starting resulting in possible serious personal injury.

## WHEEL REPLACEMENT

See Figure 11.

If you must replace a grinding wheel, be sure to obtain one with a safe rated speed at least as high as the “no load speed” RPM marked on the data plate of the grinder and which is marked to comply with ANSI B7.1.

To replace the grinding wheel, remove the wheel cover by loosening the screws. Loosen the wheel nut in a clockwise direction for the left side and a counterclockwise direction for the right side. Remove the outer flange and grinding wheel. To install a new grinding wheel, reverse the above procedure. Be sure the grinding wheel and outer flange are properly seated on the spindle shaft.

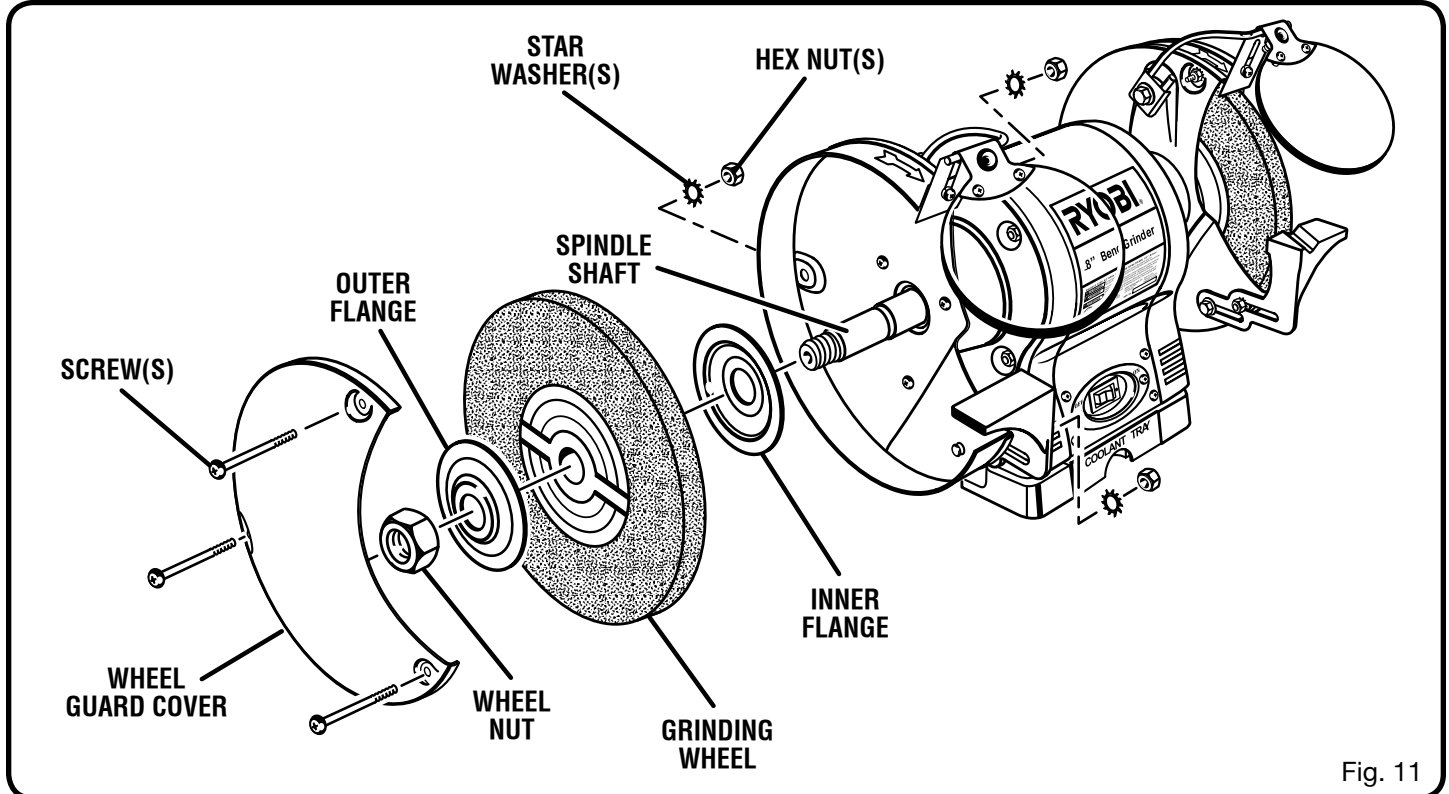
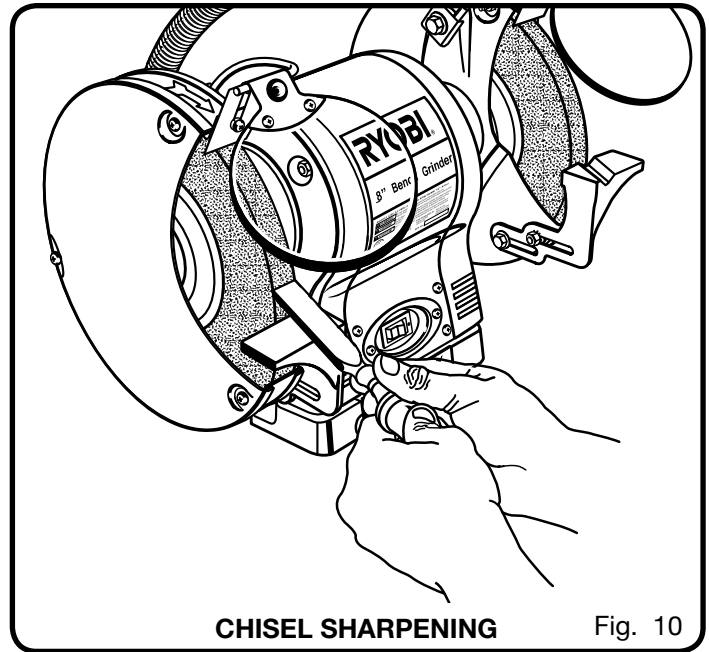

# MAINTENANCE

## ⚠ WARNING:

When servicing, use only identical Ryobi replacement parts. Use of any other part may create a hazard or cause product damage.

## GENERAL

Keep the bench grinder clean. Remove dust from working parts and beneath the grinder frequently.

Make sure the bench grinder operates properly. Check screws, nuts, and bolts for tightness.

## EXTENSION CORDS

The use of any extension cord will cause some loss of power. To keep the loss to a minimum and to prevent tool overheating, use an extension cord that is heavy enough to carry the current the tool will draw.

A wire gage size (A.W.G.) of at least 16 is recommended for an extension cord 25 feet or less in length. When working outdoors, use an extension cord that is suitable for outdoor use. The cord's jacket will be marked WA.

## ⚠ WARNING:

Check extension cords before each use. If damaged, replace immediately. Never use tool with a damaged cord since touching the damaged area could cause electrical shock resulting in serious injury.

## WORKLIGHT BULB REPLACEMENT

For models BGH625 and BGH825, Figure 12.

To remove worklight bulb, gently push the bulb into the socket and turn counterclockwise. To install the new bulb, gently push the bulb into the socket and turn clockwise.

For model BGH615, Figure 13.

To remove bulb, turn counterclockwise. To install new bulb, turn clockwise.

**Note:** To avoid the risk of fire, never use a bulb with a wattage higher than 40.

## WHEEL DRESSER

For models BGH625 and BGH825 ONLY.

Dressing a wheel is done to renew sharpness or to true up the face of the wheel.

Set the work rest of the bench grinder at a slight angle and brace the wheel dresser against it. Do not make contact with the grinding wheel until after you have turned on the motor and the wheel is rotating at full speed. Press the dresser slightly against the rotating wheel until you get a bite, then move slowly from side to side across the wheel. A small bite and many passes is better than a big bite and one pass. Work cautiously, hold the dresser with force on the work rest. Do not use excessive pressure against the grinding wheel. Proceed slowly until you master the technique.

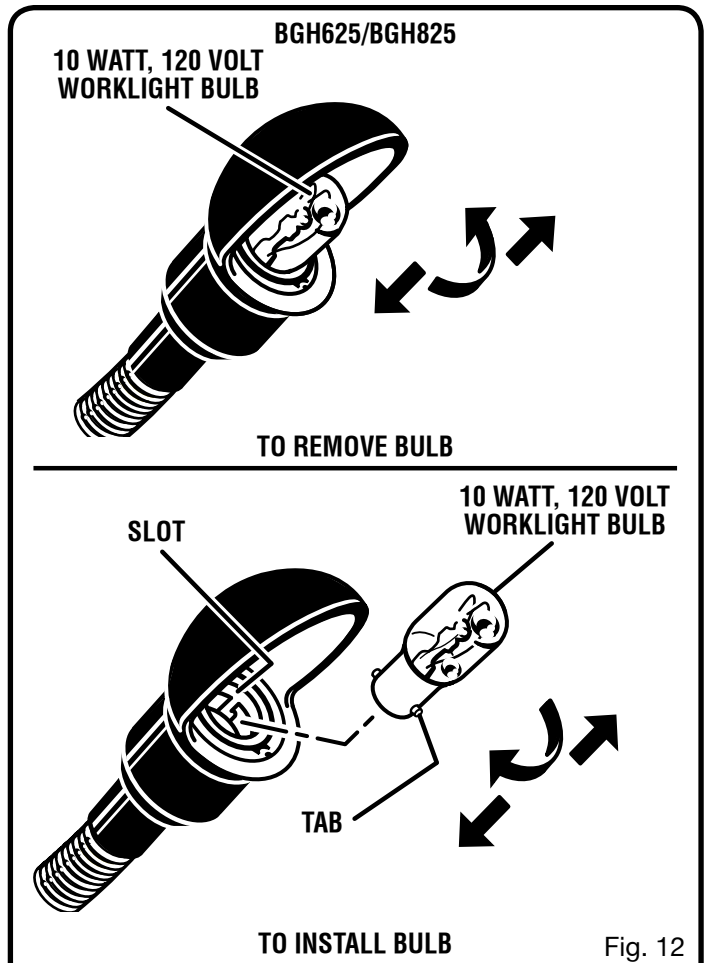

Fig. 12

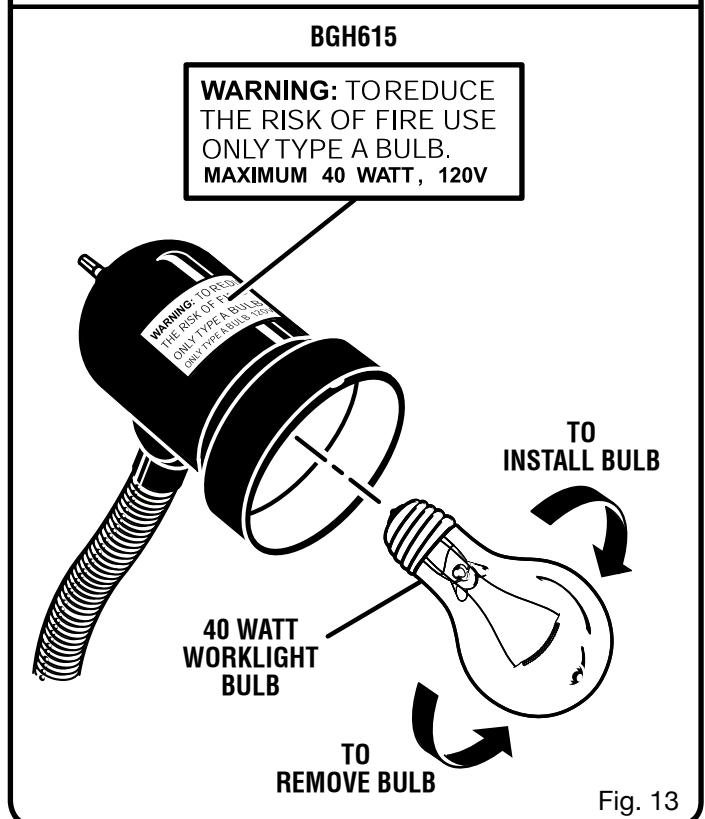

Fig. 13





# RYOBI<sup>®</sup> OPERATOR'S MANUAL

## Bench Grinder

### Models BGH615/BGH625/BGH825

#### EXTENSION CORD CAUTION

When using a power tool at a considerable distance from a power source, be sure to use an extension cord that has the capacity to handle the current the tool will draw. An undersized cord will cause a drop in line voltage, resulting in overheating and loss of power. Use the chart to determine the minimum wire size required in an extension cord. Only round jacketed cords should be used.

When working with a tool outdoors, use an extension cord that is designed for outside use. This is indicated by the letters "WA" on the cord's jacket.

Before using any extension cord, inspect it for loose or exposed wires and cut or worn insulation.

\*\*Ampere rating

(on tool data plate) 0-2.0 2.1-3.4 3.5-5.0 5.1-7.0 7.1-12.0 12.1-16.0

Cord Length	Wire Size (A.W.G.)					
25'	16	16	16	16	14	14
50'	16	16	16	14	14	12
100'	16	16	14	12	10	—

**⚠ CAUTION:** Keep the extension cord clear of the working area. Position the cord so that it will not get caught on workpiece, tools, or other obstructions while you are working with a power tool.

\*\*Used on 12 gauge - 20 amp circuit.

#### • SERVICE

Now that you have purchased your tool, should a need ever exist for repair parts or service, simply contact your nearest Ryobi Authorized Service Center. Be sure to provide all pertinent facts when you call or visit. Please call 1-800-525-2579 for your nearest Ryobi Authorized Service Center. You can also check our web site at [www.ryobitools.com](http://www.ryobitools.com) for a complete list of Authorized Service Centers.

#### • MODEL NO.

The model and serial numbers of your tool will be found on a plate attached to the motor housing. Please record the serial number in the space provided below.

- MODEL NUMBER BGH615/BGH625/BGH825
- SERIAL NUMBER \_\_\_\_\_

#### RYOBI TECHNOLOGIES INC.

1428 Pearman Dairy Road                      Anderson, SC 29625  
Post Office Box 1207                              Anderson SC 29622-1207  
Phone 1-800-525-2579

## Free Manuals Download Website

<http://myh66.com>

<http://usermanuals.us>

<http://www.somanuals.com>

<http://www.4manuals.cc>

<http://www.manual-lib.com>

<http://www.404manual.com>

<http://www.luxmanual.com>

<http://aubethermostatmanual.com>

Golf course search by state

<http://golfingnear.com>

Email search by domain

<http://emailbydomain.com>

Auto manuals search

<http://auto.somanuals.com>

TV manuals search

<http://tv.somanuals.com>