

CLASSIC

110 Gas FSD

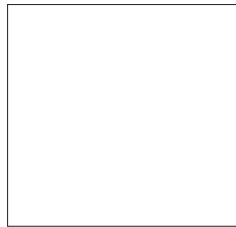

Users Guide

Installation & Service Instructions



U106100-08

Before you start...

Thank you for buying the Classic cooker. It should give you many years' trouble-free cooking if installed and operated correctly. It is, therefore, important that you read this section before you start, particularly if you have not used a gas cooker before.

This appliance is designed for domestic cooking only. Using it for any other purpose could invalidate any warranty or liability claim. In particular, the oven should NOT be used for heating the kitchen – besides invalidating claims, this wastes fuel and may overheat the control knobs.

Installation and Maintenance

Prior to installation, ensure that the local distribution conditions (nature of the gas and gas pressure) and the adjustment of the appliance are compatible. This appliance must be installed by a qualified and competent person.

The adjustment conditions for this appliance are stated on the dataplate. Otherwise, all installations must be in accordance with the relevant instructions in this booklet, with the relevant national and local regulations, and with the local gas and electricity supply companies' requirements.

Ensure that the gas supply is turned on and that the cooker is wired in and switched on (the cooker needs electricity).

Set the clock to ensure that all the ovens are functional – see the relevant section in this manual.

The cooker should be serviced only by a qualified service engineer, and only approved spare parts should be used.

Always allow the cooker to cool and then switch it off at the mains before cleaning or carrying out any maintenance work, unless specified otherwise in this guide.

Peculiar smells

When you first use your cooker it may give off a slight odour. This should stop after a little use.

Before using for the first time, make sure that all packing materials have been removed and then, to dispel manufacturing odours, turn the ovens to 220C and run for an hour.

Before using the grill for the first time you should also turn on the grill and run for 30 minutes with the grill pan in position, pushed fully back, and the grill door open.

! Make sure the room is well ventilated to the outside air (see 'Ventilation' below). People with respiratory or allergy problems should vacate the area for this brief period.

If you smell gas

- DO NOT turn electric switches on or off.
- DO NOT smoke
- DO NOT use naked flames
- DO turn off the gas at the meter or cylinder
- DO open doors and windows to get rid of the gas
- DO keep people away from the area affected
- Call your gas supplier.

Ventilation

The use of a gas cooking appliance results in the production of heat and moisture in the room in which it is installed. Therefore, ensure that the kitchen is well ventilated: keep natural ventilation holes open or install a powered cooker hood that vents outside. If you have several burners on, or use the cooker for a long time, open a window or turn on an extractor fan.

Personal Safety

! Accessible parts will become hot during use and will retain heat even after you have stopped cooking. Keep babies and children away from the cooker and never wear loose-fitting or hanging clothes while the appliance is in use. Always be certain that the controls are in the OFF position when the oven is not in use, and before attempting to clean the cooker.

When the oven is on, DO NOT leave the oven door open for longer than necessary, otherwise the control knobs may become very hot.

Cooking high moisture content foods can create a 'steam burst' when the oven door is opened. When opening the oven stand well back and allow any steam to disperse.

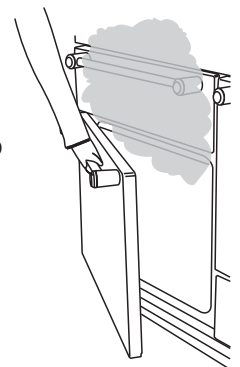

Always keep combustible materials, e.g. curtains, and flammable liquids a safe distance away from your cooker.

! Do not spray aerosols in the vicinity of the cooker while it is on.

Use dry oven gloves when applicable – using damp gloves might result in steam burns when you touch a hot surface. Do not use a towel or other bulky cloth in place of a glove – it might catch fire if brought into contact with a hot surface.

! Never operate the cooker with wet hands.

- ⚠ Do not use aluminium foil to cover shelves, linings or the oven roof.**
- ⚠ Never heat unopened food containers. Pressure build up may make the containers burst and cause injury.**
- ⚠ Do not use cooking vessels on the hotplate that overlap the edges.**
- ⚠ Do not use unstable saucepans. Always ensure that you position the handles away from the edge of the hotplate.**
- ⚠ Never leave the hotplate unattended at high heat settings. Pans boiling over can cause smoking, and greasy spills may catch on fire. Use a deep fat thermometer whenever possible to prevent fat overheating beyond the smoking point.**
- ⚠ Never leave a chip pan unattended. Always heat fat slowly, and watch as it heats. Deep fry pans should be only one third full of fat. Filling the pan too full of fat can cause spill over when food is added. If you use a combination of oils or fats in frying, stir them together before heating, or as the fats melt.**

Foods for frying should be as dry as possible. Frost on frozen foods or moisture on fresh foods can cause hot fat to bubble up and over the sides of the pan. Carefully watch for spills or overheating of foods when frying at high or medium high temperatures. Never try to move a pan of hot fat, especially a deep fat fryer. Wait until the fat is cool.

Do not use the top of the flue (the slot along the back of the cooker) for warming plates, dishes, drying tea towels or softening butter.

- ⚠ Do not use water on grease fires and never pick up a flaming pan. Turn the controls off and then smother a flaming pan on a surface unit by covering the pan completely with a well fitting lid or baking tray. If available, use a multipurpose dry chemical or foam-type fire extinguisher.**

Take care that no water seeps into the appliance.

Only certain types of glass, glass-ceramic, earthenware or other glazed containers are suitable for hotplate cooking; others may break because of the sudden change in temperature.

- ⚠ This appliance is heavy, so take care when moving it.**

Contents

Hotplate burners	Page 4
The Griddle	Page 5
Warmer	Page 5
The Grill	Page 6
The Ovens	Page 7
The Clock	Page 7
Cooking using the timer	Page 9
Oven cooking	Page 10
'S' (Slow) cooking	Page 10
Oven shelves	Page 11
The Handyrack	Page 12
Oven light	Page 12
Storage	Page 12
Cleaning your cooker	Page 14
Moving your cooker	Page 17
Troubleshooting	Page 18
General Safety Instructions	Page 21
Installation	Page 22
Servicing Notes	Page 29
Circuit Diagram	Page 34
Technical Data	Page 35

Hotplate burners

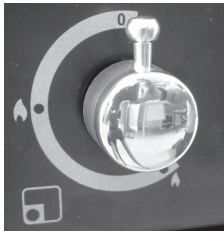

1

The drawing by each knob indicates which burner that knob controls. This is the left hand front burner.

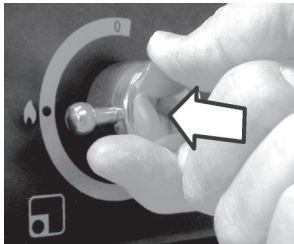

2

Each burner has a special safety device (FSD) that stops the flow of gas if the flame goes out.

Press the igniter button, and push in and turn a knob to the large flame symbol (🔥). Keep holding the knob pressed in for a few seconds. This lets gas through to the burner so the safety device can detect the flame.

If, when you let go of the control knob, the burner goes out, the safety device has not held in. Turn the control to the off position and wait one minute, then try again this time holding in the control knob for slightly longer.

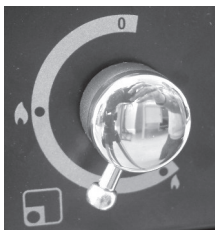

3

Adjust the flame height to suit by turning the knob. On this cooker the low position is beyond high, **not** between high and off. The small flame marks the 'low position'. Turn the knob towards it after the contents of a pan have boiled.

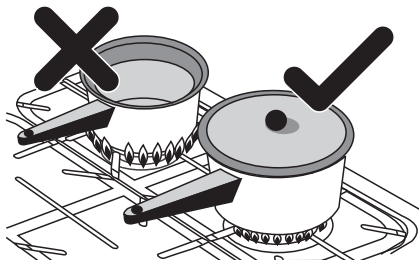

4

Make sure flames are under the pans. Using a lid will help the contents boil more quickly.

Pans and kettles with concave bases or down turned base rims should not be used.

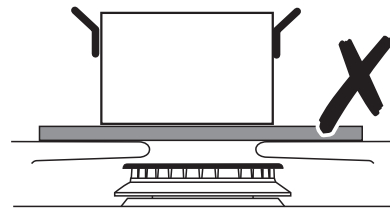

5

Simmering aids, such as asbestos or mesh mats, are **NOT** recommended. They will reduce burner performance and could damage the pan supports.

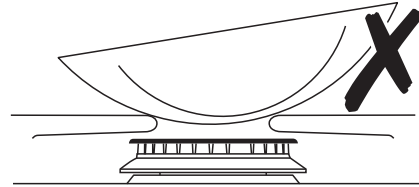

6

Avoid using unstable and misshapen pans that may tilt easily and pans with a very small base diameter e.g. milk pans, single egg poachers. The minimum pan diameter recommended is 120mm.

Pans and kettles with down turned base rims should not be used.

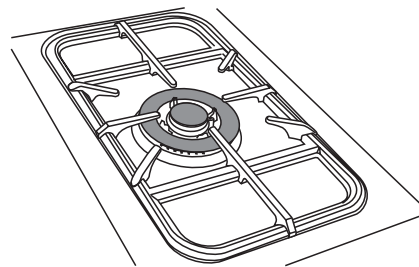

7

The Wok burner is designed to provide even heat over a large area. It is ideal for large pans and stir frying. For heating smaller pans the smaller burners may be more efficient.

If a burner flame goes out, turn the control knob off and leave it for one minute before relighting it.

You can remove the burner parts for cleaning, see the 'Cleaning your cooker' section of these instructions.

You should wipe the enamel top surface of the cooker around the hotplate burners as soon as possible after spills occur. Try to wipe them off while the enamel is still warm.

The Griddle

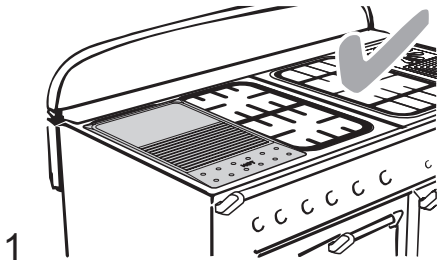

1 The griddle fits a single pan support, front to back. It is designed for cooking food on directly. Don't use pans of any kind on it. The griddle surface is non-stick and metal cooking utensils (e.g. spatulas) will damage the surface. Use heat resistant plastic or wooden utensils.

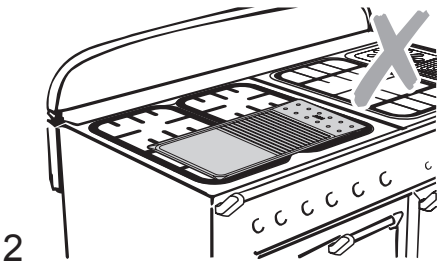

2 Don't put it crossways - it will not fit properly and will be unstable.

Don't put it on the Wok burner - it is not designed to fit the Wok burner pan support.

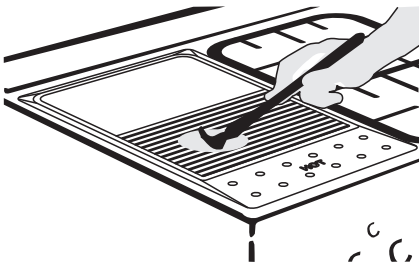

3 Position the griddle over the hotplate burners resting on the pan support. The griddle can be lightly brushed with cooking oil before use. Light the hotplate burners. Adjust the flame heights to suit.



4 Preheat the griddle for a maximum of 5 minutes before adding food. Leaving it longer may cause damage. You can reduce the heat by turning the control knobs towards the lower position (marked with the small flame symbol).

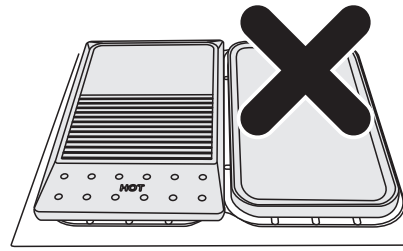

5 Always leave space around the griddle for the gases to escape. **Never** fit two griddles side by side. Large pans should also be spaced well apart. The maximum pan base diameter is 250mm.



Use the following heat settings as a guide for griddle cooking.

High/medium:

Drop scones, Bacon, Chops, Steak, Burgers.

Medium/low:

Potato cakes, Eggs, Fish cakes.

Experience will soon familiarise you with the correct setting to use for cooking.

After cooking allow the griddle to cool before cleaning.

Warmer

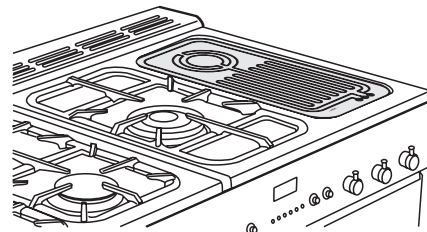

Use the warmer for keeping food warm while the final touches are put to a meal. Turn the control knob anti-clockwise to the on position. The 'HOT' indicator lights up. For best results, pre-heat a covered serving dish for 10 minutes before adding food to it.

CAUTION:- If a crack in the Warmer surface becomes visible, due to accidental damage etc., isolate the appliance from the electricity supply immediately by turning it off at the wall and arrange for its repair.

DO NOT RECONNECT THE COOKER TO THE ELECTRICITY SUPPLY UNTIL AFTER REPAIR!

The Grill

CAUTION: Accessible parts may be hot when the grill is in use. Young children should be kept away.

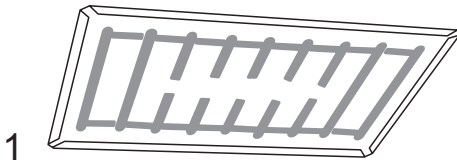

1

The burner does not glow red - food cooks from the heat of the flame. The first time you light the grill there may be a little smoke given off - this is perfectly normal.

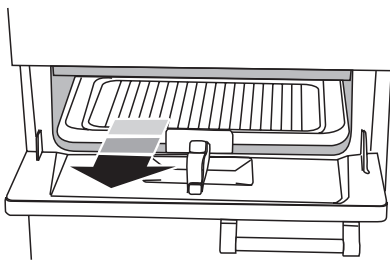

2

Remove the pan from the bottom of the grill compartment.

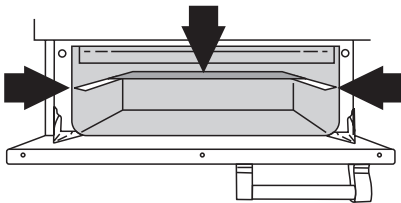

3

After placing your food on the grill tray pan, slide the grill pan onto the side supports just below the burners. Make sure it is pushed right in and touches the back stop.

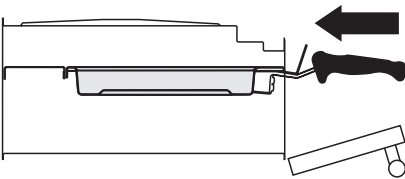

4

Make sure the grill pan is pushed right in and touches the back stop. Never close the grill door while the grill is on.

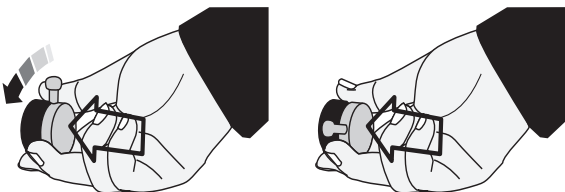

5.

The grill has a special safety device (FSD) that stops the flow of gas to the grill if the flame goes out.

Press the igniter button. Press in the grill knob and turn to the large flame symbol (🔥). Keep holding the

grill knob pressed for about 10 seconds. This lets gas through to the burner so the safety device can detect the flame.

If when you let go of the control knob the burner goes out, the safety device has not held in. Turn off the grill and wait one minute then try again this time holding in the button for slightly longer.

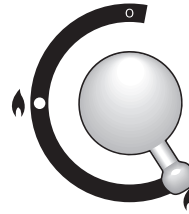

6

The low position, marked with the small flame symbol, is beyond high, not between high and off.

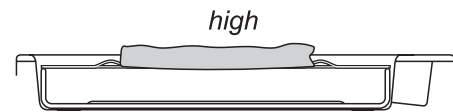

high

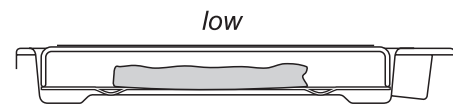

low

7

The grill pan grid can be turned over to give two grilling positions.



For best results, especially on toast, preheat the grill with the grill pan in the cooking position for two minutes before use. The grill trivet can be removed and the food placed on it while you are waiting for the grill to preheat. After placing your food on the grill pan grid, slide the grill pan onto the side supports just below the burners. Adjust the flame height to suit by turning the knob.

Don't leave the grill on for more than a few moments, without the grill pan underneath it.

You can brown the top of dishes cooked in the oven, under the grill. Remove the grill trivet and place the dish onto the base of the grill pan. Slide the grill pan along the floor of the grill cavity.

The Ovens

The clock must be set to the time of day before the ovens will work. See 'The Clock' section of these instructions for how to set the clock.

Before using for the first time, heat the ovens to Mark 7 for 30 minutes to dispel manufacturing odours. Open a window to clear the smell.

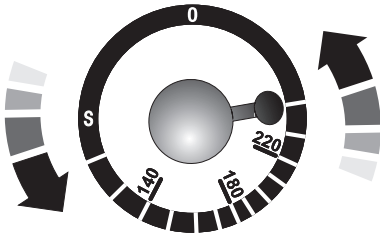

1

Push in and turn the knob controlling the oven to Gas Mark 9. The oven will light automatically.

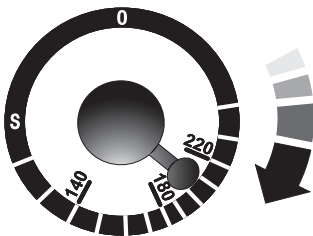

2

Turn the control knob back to the temperature you wish to cook on and for best results pre-heat for 15 minutes before placing your dishes in the oven.

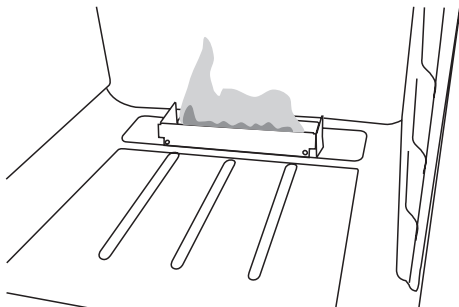

3

The ovens use our special 'Heatflow' system.

Because the oven burner is not hidden under the oven base you will see the burner flames at the back of the oven - this is perfectly normal.

The oven is protected by a safety cut off, which reduces the supply of gas to the oven if the flames go out, e.g. an interruption to the mains supply. Initially the gas will burn with a small flame but after approximately one minute the flame will become larger indicating that the oven is full on.

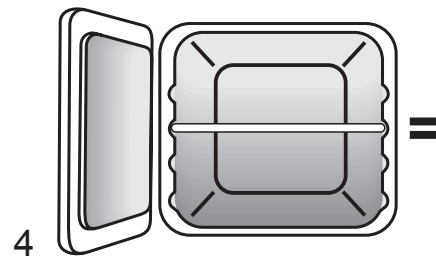

4

Dishes cooking on the central shelf will cook at the gas mark indicated on the knob.

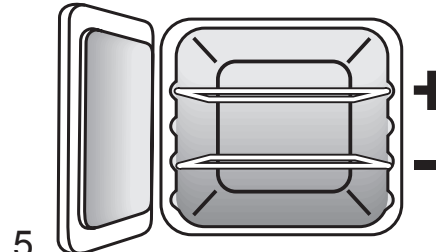

5

Dishes placed above the central position will be cooked at approx. one gas Mark higher, dishes cooked below approx. one gas Mark lower. You can therefore cook dishes requiring different gas Marks at the same time.

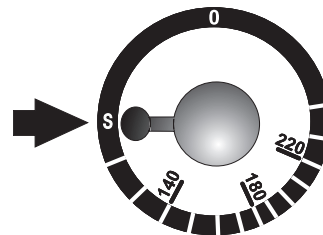

6

The 'S' setting is a very low temperature for slow cooking, overnight or while you are out or at work. The 'S' setting can also be used for keeping food warm.

The Clock

You can use the timer to turn the ovens on and off. The clock must be set to the time of day before the ovens will work.

To set the time of day

Press and hold as shown. At the same time, press (-) or (+) until the correct time shows.

Don't forget it's a 24 hour clock.

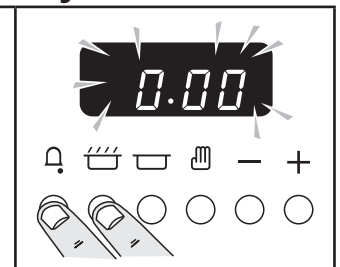

If you make a mistake or press the wrong button, turn off the power supply for a minute or two and start again. If the key symbol (Ⓚ) appears on the left of the display you have accidentally turned on the key lock feature. See the section 'Clock Special Features'.

To time something that's cooking (minute minder)

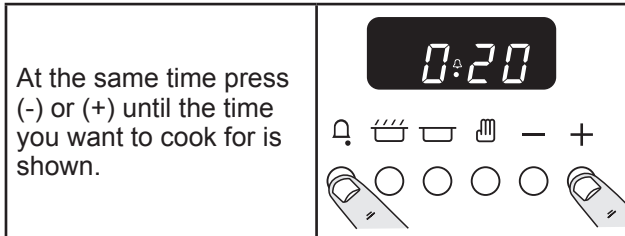
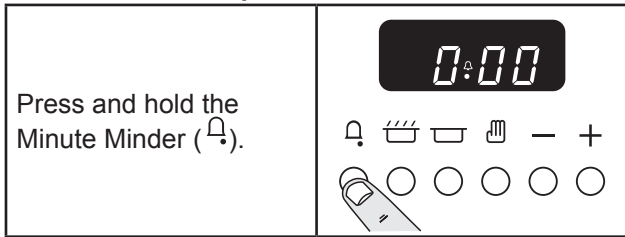

You can check time remaining by pressing 🔔 and cancel the beeper by pressing 🔔.

To stop automatically

Use when you have started the oven manually.

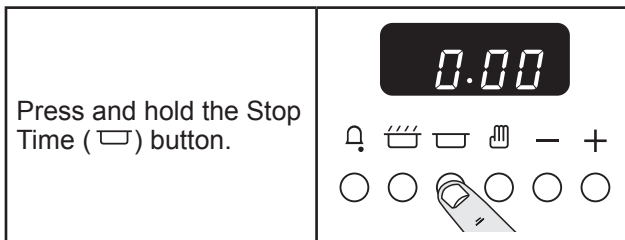

At the same time press (-) or (+) until your required 'Stop Time' shows. AUTO will show in the display. When your cooking is finished the beeper sounds. TURN THE OVEN KNOB TO 0 FIRST, then press 🔔 once to stop the beep, press 🔔 again to return to manual cooking.

To start and stop the oven automatically

Before you set the clock, you must have two numbers clearly in mind.

The 'cook period', which is the period of time you want the oven to cook.

The 'stop time', which is the time of day you want the oven to stop cooking.

You cannot set a start time directly - this is set automatically by setting the cooking period and stop time.

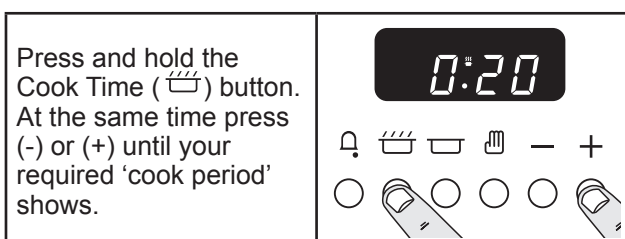

Press and hold the Stop Time (⏸) button.

At the same time press (-) or (+) until your required 'stop time' shows.

AUTO will show in the display.



Set the oven to the required temperature. When your cooking is finished the beeper sounds. TURN THE OVEN KNOB TO 0 FIRST, then press 🔔 once to stop the beep, press 🔔 again to return to manual cooking.

If you are out, don't worry about the beeper going off, it stops after a while. When you return, TURN THE OVEN KNOB TO 0 FIRST, then press 🔔 twice, to return to manual cooking.

AUTO is showing, you want to reset to manual cooking.

When cancelling an automatic setting, any cooking time already set must be returned to 0.00 before you can return to manual, by pressing the 🔔 button.

Clock Special Features

Key Lock

When the key lock is activated, the clock can be operated as usual but the oven is locked and will not come on. This means that your child could select a cook program but the program will not be activated and oven will not be switched on.

To activate the key lock

Make sure that the clock is in manual mode and cancel any active programs.

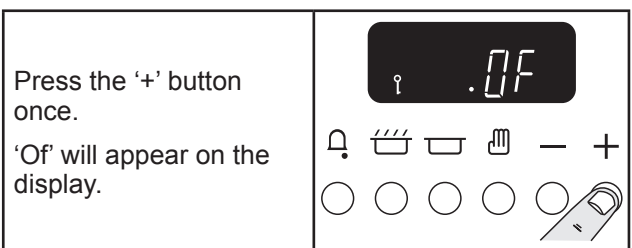
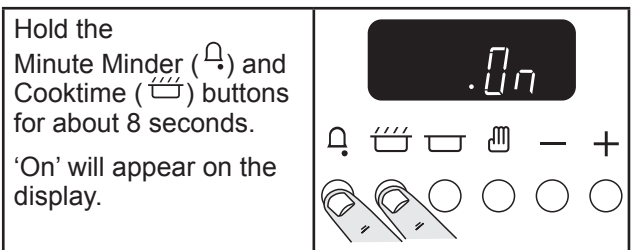

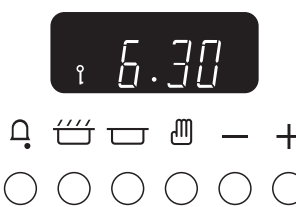
<p>The clock oven control functions are now locked.</p> <p>After a few seconds the display will revert to show the time of day and the key symbol (i).</p>	
--	---

Cooking using the timer

The timer can be used to turn just one oven or both on and off automatically. The start and stop time must be the same for both ovens but different cooking temperatures can be set.

If you want to turn one of the ovens on at the same time as the timer is set for automatic cooking, you must wait until the timer has turned on the oven/ ovens first. Then you can adjust either of them manually in the normal way.

You can set the oven to turn on any time over the following 24 hour period

If you want to cook more than one dish, choose dishes that require approximately the same time. However, dishes can be 'slowed down' slightly by using small containers and covering them with aluminium foil, or 'speeded up' slightly by cooking smaller quantities or placing in larger containers.

Very perishable foods such as pork or fish should be avoided if a long delay period is planned, especially in hot weather.

Don't place warm food in the oven.

Don't use an oven already warm.

Don't use if an adjoining oven is warm.

Avoid using wine or beer if there is a delay period, as fermentation may take place.

To avoid curdling, cream should be added to dishes just before serving.

Fresh vegetables, which may discolour during a delay period, should be coated in melted fat or immersed in a water and lemon juice solution.

Many frozen foods are ideal for delayed cooking and can be placed in the oven while still frozen.

Fruit pies, custard tarts or similar wet mixtures on top of uncooked pastry are only satisfactory if there is a short delay period. Dishes containing leftover cooked meat or poultry should not be cooked automatically if there is a delay period.

Whole poultry must be thoroughly defrosted before placing in the oven.

Check that meat and poultry are fully cooked before serving.

To turn off the key lock

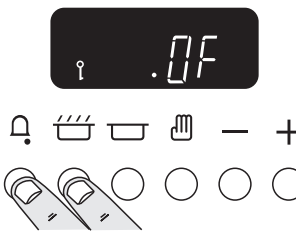
<p>Hold the Minute Minder (i) and Cooktime (tray) buttons for about 8 seconds.</p> <p>'Of' will appear on the display.</p>	
--	---

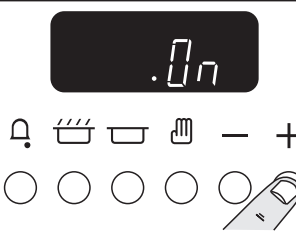
<p>Press the '+' button once. 'On' will appear on the display.</p>	
--	---

After a few seconds the display will revert to show the time of day.

The oven and the clock oven control functions can now be used normally.

Oven cooking

The wire shelves should always be pushed firmly to the back of the oven.

Baking trays with food cooking on them should be placed level with the front edge of the oven's wire shelves. Other containers should be placed centrally. Keep all trays and containers away from the back of the oven, as overbrowning of the food may occur.

For even browning, the maximum recommended size of a baking tray is 325mm (12³/₄") by 305mm (12").

When the oven is on, don't leave the door open for longer than necessary, otherwise the knobs may get very hot.



- Always leave a 'fingers width' between dishes on the same shelf. This allows the heat to circulate freely around them.
- To reduce fat splashing when you add vegetables to hot fat around a roast, dry them thoroughly or brush lightly with cooking oil.
- Where dishes may boil and spill over during cooking, place them on a baking tray.

The oven is protected by a safety cut off, which reduces the supply of gas to the oven if the flames go out, e.g. an interruption to the mains supply.

- Plates can be warmed in the oven on the 'S' setting. The 'S' setting can be used to keep foods hot for 3-4 hours after 'normal' cooking, without drying out or overbrowning.
- The Cook & Clean oven liners (see *Cleaning your cooker*) work better when fat splashes are avoided. Cover meat when cooking.
- Sufficient heat rises out of the oven while cooking to warm plates in the grill compartment.
- If you want to brown the base of a pastry dish, preheat a baking tray for 15 minutes before placing the dish in the centre of the tray.

'S' (Slow) cooking

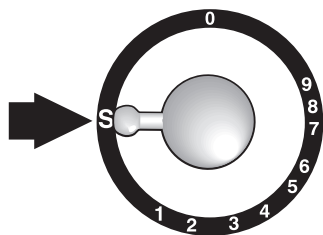

The 'S' setting is a very low temperature for slow cooking, overnight or while you are out or at work. The 'S' setting can also be used for keeping food warm.

You can cook on 'S' throughout, or use a 30 minute 'boost' period at gas 190°C and then 'S' cook.

When roasting joints, poultry or pot roasting, always cook at 190°C for 30 minutes at the beginning of the cooking period.

You can 'S' cook for periods of 6 to 12 hours. This technique is particularly useful if you want to cook a dish overnight or while you are out at work during the day.

Frozen foods must be thoroughly thawed out before 'S' cooking.

Whole poultry should not be cooked on 'S'. Chicken casseroles are fine.

Casseroles must be brought to boiling point on the hotplate immediately before 'S' cooking.

Poultry and rolled joints should not be stuffed before cooking. The stuffing should be cooked separately. Poultry and pork should be cooked in the top half of the oven, and other meats not lower than shelf position 4.

A roasting joint should be covered with cooking foil, or with a roasting bag to reduce shrinkage and retain juices.

Should further browning be necessary, uncover the meat and increase the temperature to 180°C for a short period.

Cut root vegetables into small pieces unless cooking whole, e.g. jacket potatoes.

Cover dishes tightly with a lid or foil to prevent evaporation and transfer of flavour.

Once the oven has been loaded and the 'S' setting is in operation resist the temptation to open the oven door. Heat will be lost and the cooking time extended.

A meat thermometer is recommended for checking that a joint or poultry is sufficiently cooked. Insert the probe through the thickest part of the meat. The temperatures to be expected are as follows.-

Beef	rare	60°C / 140°F
	medium	71°C / 160°F
	well done	77°C / 170°F
Lamb		82°C / 180°F
Pork	fresh	88°C / 190°F
	cured	77°C / 170°F
Poultry		90°C / 195°F
Veal		77°C / 170°F

Oven shelves

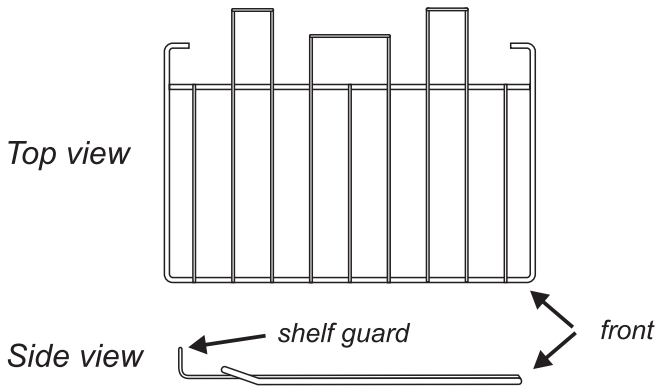

the shelf guard should be at the back pointing upwards

The oven shelves can be easily removed and refitted.

Pull the shelf forward until the back of the shelf is stopped by the shelf stop bumps in the oven sides.

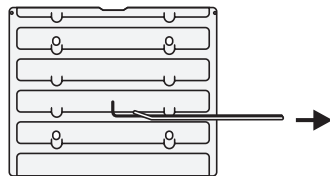

Lift up the front of the shelf so the back of the shelf will pass under the shelf stop and then pull the shelf forward.

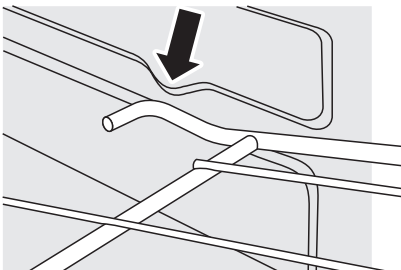
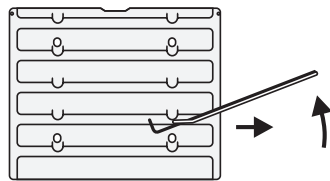

To refit the shelf, line up the shelf with a groove in the oven side and push the shelf back until the ends hit the shelf stop. Lift up the front so the shelf ends clear the shelf stops, and then lower the front so that the shelf is level and push it fully back.

The Handyrack

The maximum weight that can be held by the Handyrack is 5.5kg (12lb). It should only be used with the supplied meat tin, which is designed to fit the Handyrack. Any other vessel could be unstable.

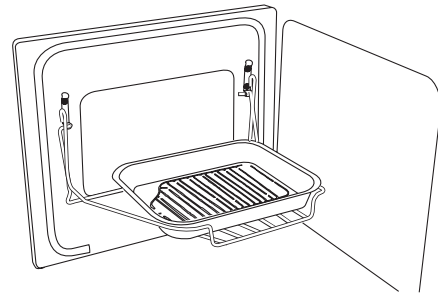

The Handyrack fits to the left hand oven door only. Food cooking on it is easy to attend to, because it's accessible when the door is open. It can be fitted at two different heights. One of the oven shelves must be removed and the other positioned to suit.

When the Handyrack is used in its highest position, other dishes can be cooked on the bottom shelf position of the oven or standing on the base of the oven.

When the Handyrack is used in its lowest position, other dishes can be cooked on the second shelf position of the oven.

To fit the Handyrack, locate one side of it on the door bracket.

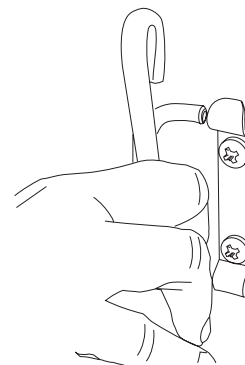
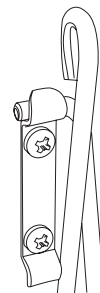

Then spring the other side out to clip it onto the other bracket.

Oven light

◀ Oven
light ▶

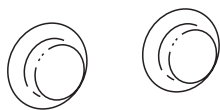

Press the appropriate button to turn on one of the oven lights.

If one of the oven lights fail, *turn off the power supply* before you change the bulb. See the 'Troubleshooting' section for details on how to change an oven light bulb.

Storage

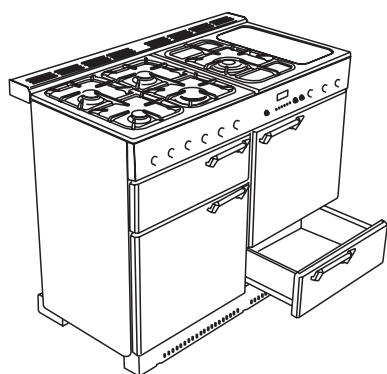

The bottom drawer is for storing oven trays and other cooking utensils. It can get very warm, don't store anything in it that may melt or catch fire. The drawer can be removed completely by pulling it right out and up.

Cleaning your cooker

Essential information

Before thorough cleaning isolate the electricity supply. Remember to switch on the electricity supply before use.

Never use paint solvents, washing soda, caustic cleaners, biological powders, bleach, chlorine based bleach cleaners, coarse abrasives or salt. Don't mix different cleaning products - they may react together with hazardous results.

Recommended cleaning materials are shown in the table at the end of this section.

If you want to move your cooker for cleaning, see the section called 'Moving your cooker'.

All parts of the cooker can be cleaned with hot soapy water - **but take care that no surplus water seeps into the appliance.**

For cleaning materials see the 'Cleaning Table' at the end of this section.

Hotplate burners

Some models have a separate trim ring, which fits on the burner head.

The burner heads and caps can be removed for cleaning. Make sure they are absolutely dry before replacing.

The LH hotplate

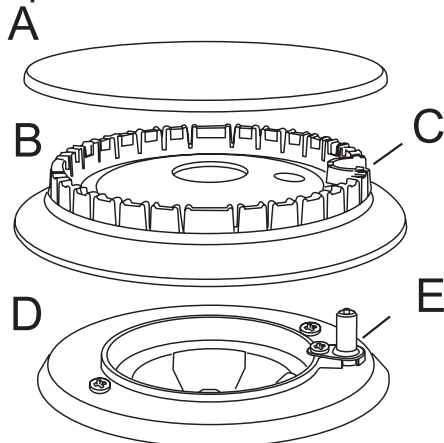

A cap, B head, C notch, D base, E electrode

When refitting the burner head, make sure that the notch lines up with the electrode or hole in the base. Check that the burner head is level and that the cap is fitted centrally on the burner head.

The Wok burner

The Wok burner is a little more complicated but it also can be taken apart for cleaning.

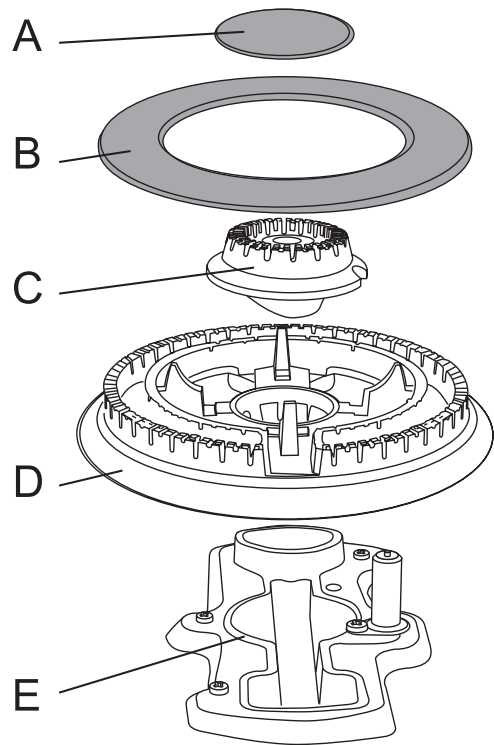

Wok burner

- A inner burner cap, B outer burner cap
C inner burner head D outer burner head
E Wok burner base

When reassembling the Wok burner, turn over the large base ring and find the 'D' shaped area.

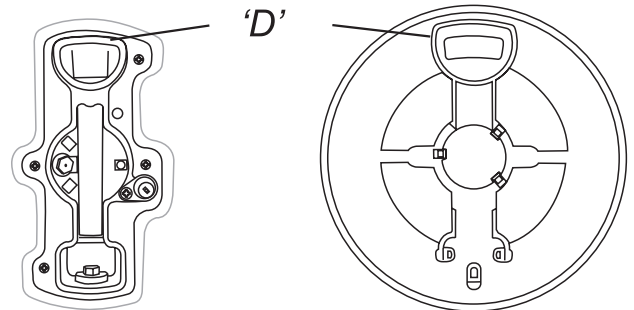

burner base

underside of burner head

Turn the head until the 'D' matches the one on the burner base. Turn the head over and place it on the burner base.

To fit the small inner burner, find the larger electrode notch in the burner rim. Line this up with the white ignition electrode and place the inner burner on the large base ring.

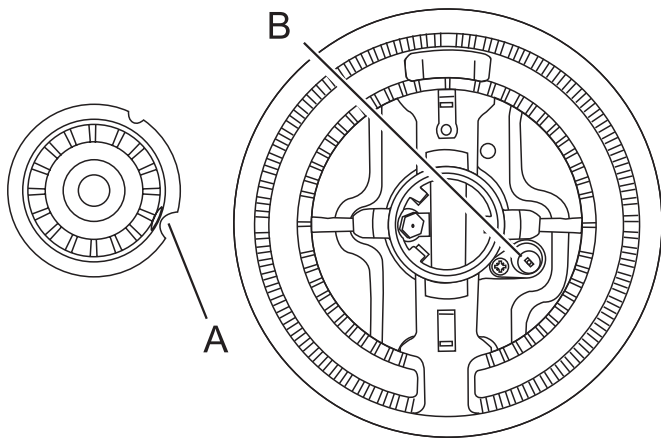

A electrode notch B ignition electrode

Now fit the two trim rings, making sure that they are sitting down properly.

Griddle

Always clean the griddle after use. Allow to cool completely before removing. Immerse the griddle plate in hot soapy water. Use a soft cloth or, for stubborn stains, a nylon washing up brush.

NEVER USE CAUSTIC OR ABRASIVE CLEANERS AS THESE WILL DAMAGE THE SURFACE.

Control Panel and Doors

The control panel and control knobs should only be cleaned with a soft cloth wrung out in clean hot soapy water - **but take care that no surplus water seeps into the appliance.** Wipe with a clean dampened cloth then polish with a dry cloth. The oven doors should only be cleaned with a soft cloth wrung out in clean hot soapy water.

Grill

The face of the grill burner will darken with use - this is perfectly normal. Any fat or grease will burn off. Do not try to clean it - the small holes could get blocked and affect burner performance.

The grill pan and grid should be washed in hot soapy water. After grilling meats or any foods that soil, leave to soak for a few minutes in the sink immediately after use. Stubborn particles may be removed from the grill by using a nylon brush.

Oven

Cleaning is easier if carried out while the oven is still warm. Before cleaning, cover the burner to prevent the burner holes becoming blocked.

The inside of the oven and inner door panel can be cleaned using an approved cleaner see the table at the end of this section.

Take care not to disturb the oven thermostat temperature sensor at the top of the oven opening.

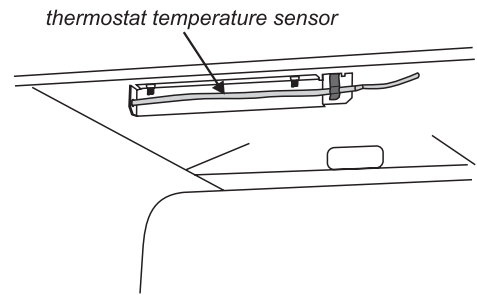

The enamelled oven burner trim (supplied with some models only) can be removed for cleaning.



The oven burner trim hooks onto the front of the oven burner bracket.

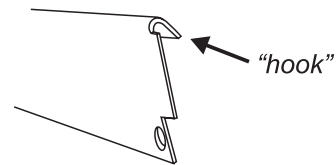

When refitting make sure that the trim is in the middle of the front of the oven burner bracket.

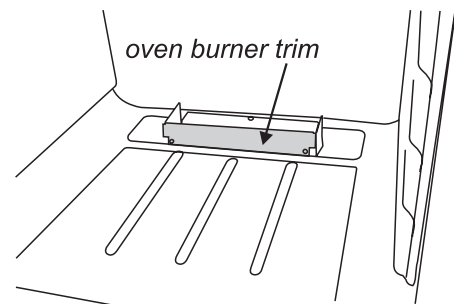

The Oven side linings

The oven has removable oven side lining panels that have been coated with special enamel that partly cleans itself. This does not stop all marks on the lining, but helps to reduce the amount of manual cleaning needed.

The Cook & Clean panels work better above gas 190°C. If you do most of your cooking below this temperature, occasionally remove the panels and wipe with a lint free cloth and hot soapy water. The panels should then be dried and replaced and the oven heated at 220°C for about one hour. This will ensure the Cook & Clean panels are working effectively.

Don't use steel wool (Brillo) or any other materials that will scratch the surface. Don't use oven cleaning pads.

Before cleaning the oven, cover the burner at the rear to stop the holes getting blocked as you clean. If they are accidentally blocked, clean them out with thin wire, such as fuse wire.

Removing the Oven Linings

The lining panels can be removed for cleaning and for cleaning behind. Remove the shelves first.

Moving your cooker

Switch off the electricity supply.

The cooker is heavy, two people may be required to move it. The cooker is fitted with one roller at the front and two at the back. There are also two screw down levelling feet at the front.

The front roller, designed for moving the cooker can be wound down. The levelling tool that controls this roller is in the storage drawer compartment.

Remove the storage drawer (by pulling it right out and lifting it up slightly) and you should see the levelling tool.

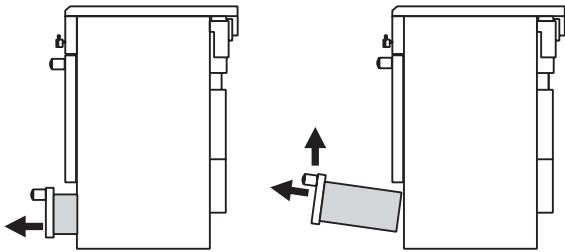

Your installer may not have left the levelling tool in place. If not, locate it as shown. If you cannot find the levelling tool, contact your installer. See the Installation section of these instructions where your installer should have written their contact details.

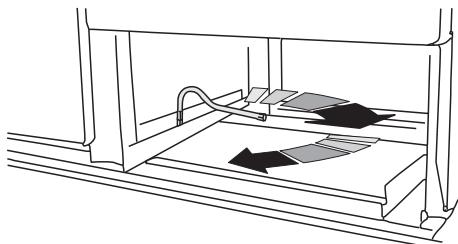

Turn the levelling tool clockwise, two full (180°) turns. It will be stiff. The front of the oven will rise slightly as the roller drops down.

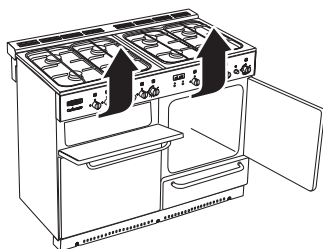

Open the grill door and right hand oven door so that you can get a good grip on the bottom of the fascia panel as you move the oven.

Do not move the oven by pulling the hand rail, door handles or knobs.

Move the oven a bit at a time, checking behind it to make sure the gas hose is not caught. Make sure both electricity and gas cables have sufficient slack to move the cooker forward as you go along.

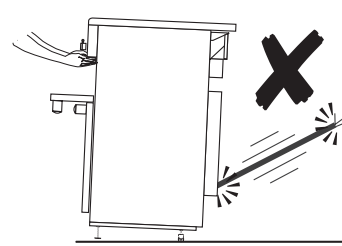

If a stability chain is fitted, release it as you ease the cooker out.

When you replace the cooker, wind it down off the rollers by turning the levelling tool anti-clockwise. This is important. It will stop the cooker moving accidentally, while in use.

When you replace the cooker, wind it down off the rollers by turning the levelling tool anti-clockwise. This is important. It will stop the cooker moving accidentally, while in use.

Troubleshooting

Hotplate ignition or hotplate burners faulty

Is the power on? Is the clock illuminated? If not there maybe something wrong with the power supply.

See 'power supply' section further on.

Are the sparker (ignition electrode) or burner slots blocked by debris?

Is the burner trim correctly located?

Are the burner caps correctly located?

See the section entitled 'Cleaning your cooker'

Hotplate burners will not light

If only one or all the hotplate burners will not light, make sure that the parts have been replaced correctly after wiping or removing for cleaning.

Check that there is not a problem with your gas supply. You can do this by making sure that other gas appliances you may have are working.

Do the burners spark when you push the button? If not check the power is on - is the clock illuminated?

A crack has appeared in the Warmer plate's surface

Disconnect the cooker immediately from the power supply and arrange for its repair. Don't use the cooker until after the repair. See the HELP leaflet for how to contact a service person.

The knobs get hot when I use the oven or the grill, can I avoid this?

Yes, this is caused by heat rising from the oven or the grill, and heating them up. Don't leave the oven door open. Make sure that the grill pan is pushed right back to the 'back stop' when grilling.

Grill Ignition faulty

Is the power on? Is the clock illuminated? If not there maybe something wrong with the power supply. See 'power supply' section further on.

Grill not cooking properly

Are you using the pan and trivet supplied with the cooker? Is the pan being used on the runners, not the floor of the compartment? Is the grill tray pushed fully back to stop?

Oven ignition faulty

Is the power on? Is the clock running? - if not there may be something wrong with the power supply.

See the section on 'Checking the power supply'.

Check that the electrode and burner slots are not blocked by debris.

Has the Timer been set to auto by mistake, or after power cut?

Has the Timer been set correctly but oven tap not left OFF by mistake?

Is the key symbol (Ⓘ) showing in the display? See the Clock section of the instructions for more information on the key lock feature of the clock.

Oven not coming on when turned on manually

Is the power on? Is the clock illuminated? If not there may be something wrong with the power supply. Is the cooker supply on at the isolator switch? Is the clock flashing 0.00? If so set it to the correct time of day. Has the Timer been set to AUTO by mistake. If AUTO is showing on the clock display, press the 'cook period' button and reduce any set cooking time showing to 0.00, with the (+) and (-) buttons. Press the  button twice.

Is the key symbol (Ⓘ) showing in the display? See the Clock section of the instructions for more information on the key lock feature of the clock.

Oven not coming on when automatic cooking

Timer set correctly but oven knob left OFF by mistake?

Is the key symbol (Ⓘ) showing in the display? See the Clock section of the instructions for more information on the key lock feature of the clock.

The oven is not cooking evenly

Do not use a tin or baking tray larger than 340mm x 305mm.

If you are cooking a large item, be prepared to turn it round during cooking.

If two shelves are used, check that space has been left for the heat to circulate. When the baking tray is put into the oven, make sure it is placed centrally on the shelf.

Check that the door seal is not damaged and that the door catch adjusted so that the door is held firmly against the seal.

NB the seal is intended to have a gap at the bottom of the door

A dish of water when placed on the shelf should be the same depth all over. (For example, if it is deeper at the back, then the back of the cooker should be raised up or the front lowered). If the cooker is not level arrange for your supplier to level it for you.

Food is cooking too slowly, too quickly, or burning

Cooking times may differ from your previous oven.

The oven control settings and cooking times are intended to be used only as a guide. Individual tastes may require the temperature to be altered either way, to get the results you want. Try cooking at a higher shelf position and/or higher temperature. Oven cooking times and temperatures may need to

be increased when other burners are in use. Are the oven burner ports blocked with spilt food?

Oven temperature getting hotter as the cooker gets older

If turning the knob down has not worked or only worked for a short time then you may need a new thermostat. This should be fitted by a service person.

The oven light is not working

The bulb has probably blown. You can buy a replacement bulb (which is not covered under the guarantee) from a good electrical shop. Ask for an Edison screw fitting 15w 230v lamp, FOR OVENS. It must be a special bulb, heat resistant to 300°C.

Open the oven door and remove the Handyrack (if fitted) and oven shelves.

Turn off the power supply.

Unscrew the bulb cover by turning anticlockwise. Unscrew the old bulb. Screw in the new bulb, screw back the bulb cover. Turn on the electricity supply and check that the bulb now lights.

Power supply - You think there may be a problem with it

Check the socket by trying out another piece of electrical equipment in it.

Power failure

In the event of a failure in the electrical supply the hotplate may be lit using a match.

If there is an installation problem and I don't get my original installer to come back to fix it who pays?

You do. Service organisations will charge for their call outs if they are correcting work carried out by your original installer. It's in your interest to track down your original installer.

What cleaning materials are recommended for the cooker?

See the 'Cleaning your cooker' section for recommended cleaning materials. We do not recommend Mr. Muscle, as it contains chemicals that may damage the surfaces of your cooker.

Installation

You must be aware of the following safety requirements & regulations

Prior to installation, ensure that the local distribution conditions (nature of the gas and gas pressure) and the adjustment of the appliance are compatible.

This appliance shall be installed in accordance with the regulations in force and only in a well ventilated space. Read the instructions before installing or using this appliance.

In your own interest and that of safety, it is law that all gas appliances be installed by competent persons. Registered installers undertake to work to safe and satisfactory standards. Failure to install the appliance correctly could invalidate any warranty or liability claims and lead to prosecution. The cooker must be installed in accordance with

- ▶ All relevant Standards / Codes of Practice, in particular BS 5440 Part 2 2000,
- ▶ Any Gas Safety regulations.
- ▶ The relevant Building / IEE regulations.

Provision of Ventilation

This appliance is not connected to a combustion products evacuation device. Particular attention shall be given to the relevant requirements regarding ventilation.

Location of Cooker

The cooker may be installed in a kitchen/kitchen diner but NOT in a room containing a bath or shower.

NOTE:

An appliance for use on LPG shall not be installed in a room or internal space below ground level. e.g. in a basement.

All models are supplied set for use on either natural gas or for use on LP gas.

They cannot be converted from one gas to the other.

This appliance is designed for domestic cooking only. Use for any other purpose could invalidate any warranty or liability claim.

Dear Installer

Before you start your installation, please complete the details BELOW.

If your customer has a problem relating to your installation they will be able to contact you easily.

Thank you

Installer's Name

Installer's Company

Installer's Telephone number

You will need the following equipment to complete the cooker installation satisfactorily

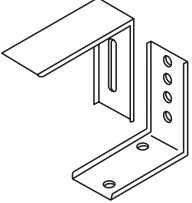
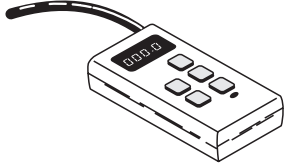
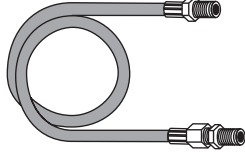
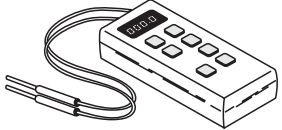
			
<p>STABILITY BRACKET If the cooker is to be supplied with gas through a flexible hose, a stability bracket or chain must be fitted. These are not supplied by with the cooker but are available at most builders merchants.</p>	<p>GAS PRESSURE TESTER It is important the gas pressure is set correctly</p>	<p>FLEXIBLE GAS HOSE IMPORTANT Flexible hose must be suitable for 70°C rise when the supply connection is above 610mm from the floor. For LPG, a suitable hose for the gas type and pressure must be used. A hose is not supplied with the cooker.</p>	<p>MULTIMETER (for electrical checks) Make sure the installation is electrically safe.</p>

You will also need the following tools:

- | | |
|--|--|
| 1. Electric drill | 5. Flat head screwdriver |
| 2. Masonry drill bit & Rawplugs
(only required if fitting the cooker on a stone or concrete floor) | 6. Spirit level |
| 3. Steel tape measure | 7. Pencil |
| 4. Cross head screwdriver | 8. Adjustable spanner |
| | 9. Screws for fitting stability bracket |

Positioning the Cooker

The diagrams below show the minimum recommended distance from the cooker to nearby surfaces.

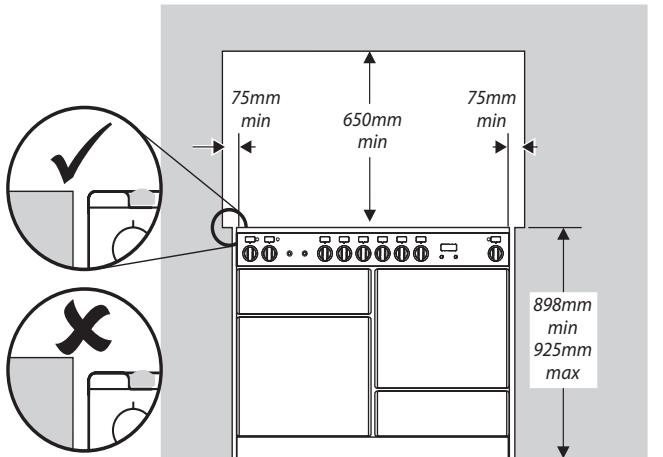

The hotplate surround should be level with, or above, any adjacent work surface. Above hotplate level a gap of 75mm should be left between each side of the cooker and any adjacent vertical surface.

For non-combustible surfaces (such as unpainted metal or ceramic tiles) this can be reduced to 25mm.

A minimum space of 650mm is required between the top of the hotplate and a horizontal combustible surface.

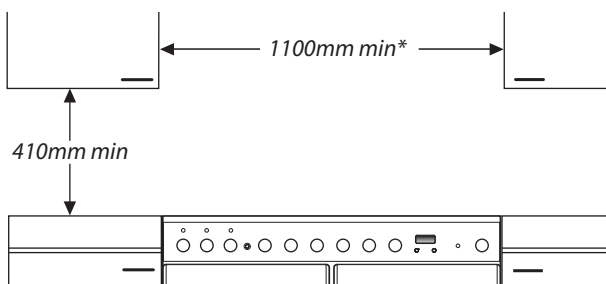

*Any cooker hood should be installed in accordance with the hood manufacturer's instructions.

Surfaces of furniture and walls at the sides and rear of the appliance should be heat, splash and steam resistant. Certain types of vinyl or laminate kitchen furniture are particularly prone to heat damage and discolouration. We cannot accept responsibility for damage caused by normal use of the cooker to any material that de-laminates or discolours at temperatures less than 65°C above room temperature.

For safety reasons curtains must not be fitted immediately behind the cooker.

We recommend a gap of 1110mm between units to allow for moving the cooker. If a flush fit is required, fit the cooker up to the unit at one side then fit the unit the other side. Do not box the cooker in; it must still be possible to move the cooker in and out for cleaning and servicing. The cooker should not be placed on a base.

Checking the parts

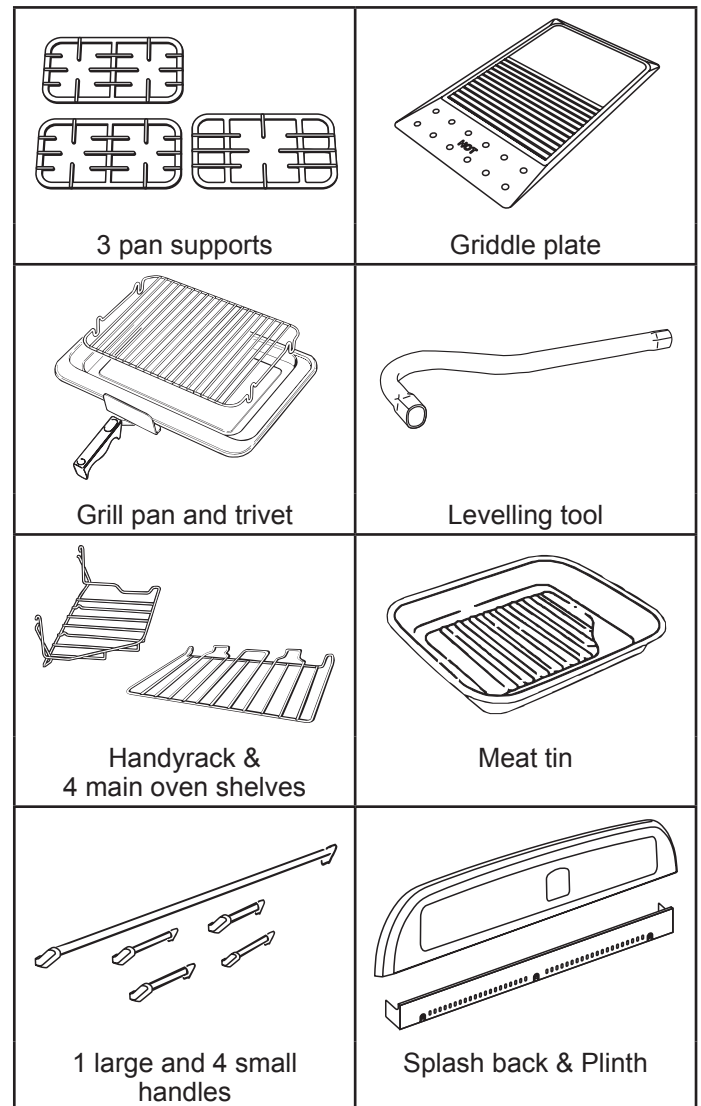

A clearance of 130mm is required if the cooker is near a corner of the kitchen to allow the oven doors to open.

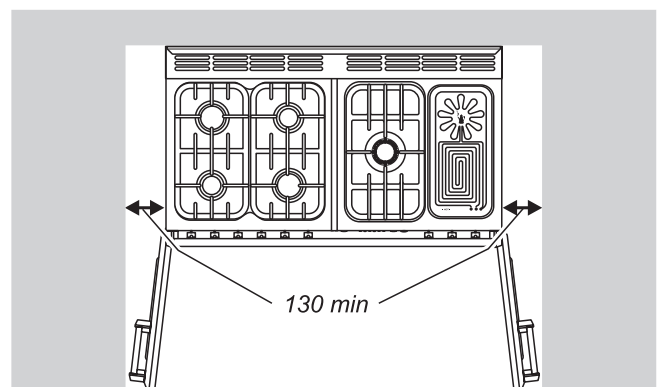

Unpacking the Cooker

Do not take any packaging off the cooker until it is directly in front of the place it is to be installed (unless it will not fit through a door in its outer packaging). See the loose unpacking sheet.

Moving the Cooker

The cooker is very heavy. Take great care. We recommend two people manoeuvre the cooker. Ensure that the floor covering is firmly fixed, or removed to prevent it being disturbed when moving the cooker around. You will need the levelling tool. From the back tilt the cooker forward and remove the rear half of the polystyrene base pack.

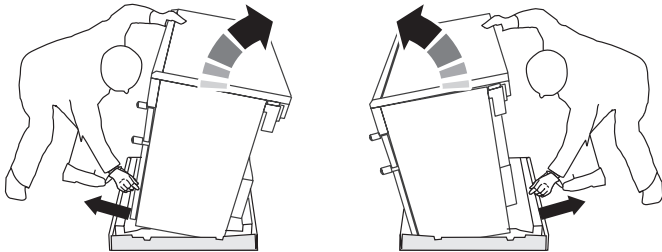

Repeat from the front and remove the front half of the poly base. Pull the drawer out to its furthest point. Lift it up and out.

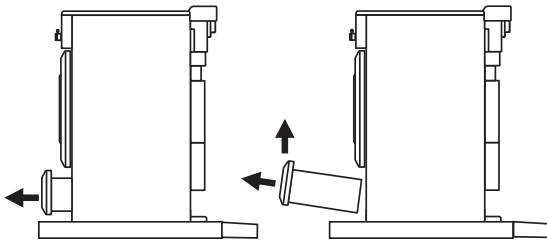

Fit the levelling tool on the rectangular adjuster as shown below.

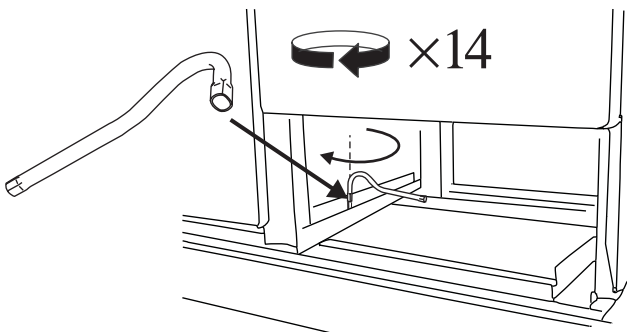

LOWER THE FRONT ROLLER by doing 14 complete (360°) turns clockwise. (This means turning and removing the levelling tool 56 times).

Now LOWER THE TWO REAR ROLLERS. First fit the levelling tool on the hexagonal adjusting nut as shown below.

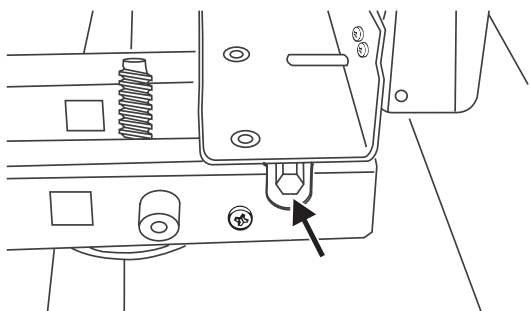

Make 10 complete (360°) turns clockwise. (This means turning and removing the levelling tool 20 times).

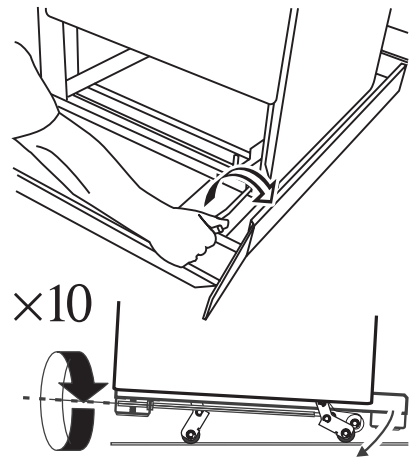

Make sure you lower BOTH REAR ROLLERS. There are two adjusting nuts, one for each roller, at both the front bottom corners of the cooker.

Unfold the rear edge of pack base tray. Carefully push the cooker backwards off the pack base and into position. Take care not to damage the power cable. Push the cooker close to its final position, leaving just enough space to get behind it.

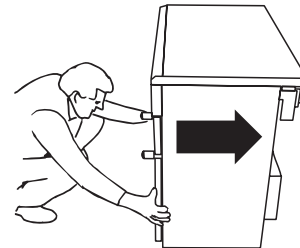

Levelling

You are recommended to use a spirit level on a shelf in one of the ovens to check for level.

Place the cooker in its intended position taking care not to twist it within the gap between the kitchen units as damage may occur to the cooker or the units.

The rollers can be adjusted to level the cooker. To adjust the height of the rear of the cooker use the levelling tool supplied to turn the adjusting nuts at the front bottom corners of the cooker.

Adjust the height of the front roller to level the cooker. Turn clockwise to raise the cooker and anticlockwise to lower.

When you are satisfied with the height and level raise the front of the cooker by one turn of the front roller adjuster. Screw down the front feet to meet the floor. Screw the front roller adjuster anticlockwise to raise the front roller so that the front of the cooker is supported on the feet, **not** the front roller, to prevent accidental movement of the cooker.

Leave the levelling tool on the adjuster with the handle of the tool facing the rear of the cooker, so that the customer can use it if they wish to move the cooker.

Replace the drawer by locating on side runners and push in.

Fit the Handles

Remove the 4mm Allen screws from the doors with the hexagon key tool. Use the screws to fit the door handles.

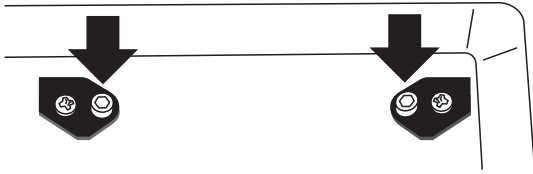

The handles should be above the fixings.

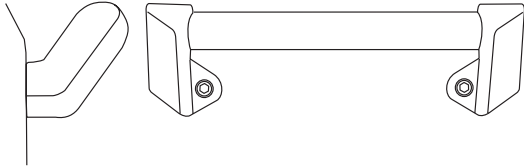

Remove the 4mm Allen screws from the top corners of the fascia and fix the front handrail in position.

Fitting the splash back (optional)

Remove the two fixing screws (3mm hexagonal socket head) and nuts that pass through the top of the rear flue grille. Hold the splash back in position. From the rear refit the 2 fixing screws and nuts.

Fitting a stability bracket

A stability bracket or chain (**not supplied with the cooker**) should be fitted when the cooker is connected to a flexible gas supply.

When fitting a stability bracket read these instructions together with the leaflet supplied with the bracket.

1. Place the cooker in its intended position and level the cooker.
2. Draw a pencil line 100mm from the front edge of the levelling feet.
3. Mark the centre line for the bracket by measuring 550mm from the left hand side of the cooker.

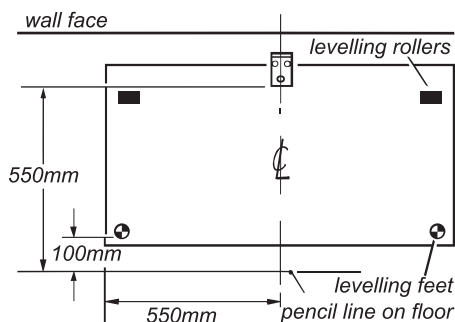

4. Lower the front roller and move the cooker forward.
5. Measure back from the pencil line 550mm to locate the front edge of the bracket. Fix the bracket to the floor.
6. Measure the height from floor level to engagement edge in back of cooker. Add 3mm to this dimension and assemble the stability bracket to this height. (i.e. from floor level to underside of the top member) and

ensure the bracket does not foul the oven burner assembly.

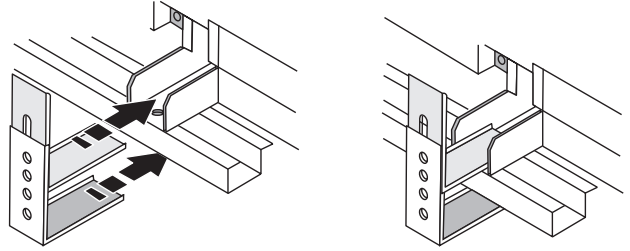

Gas Connection

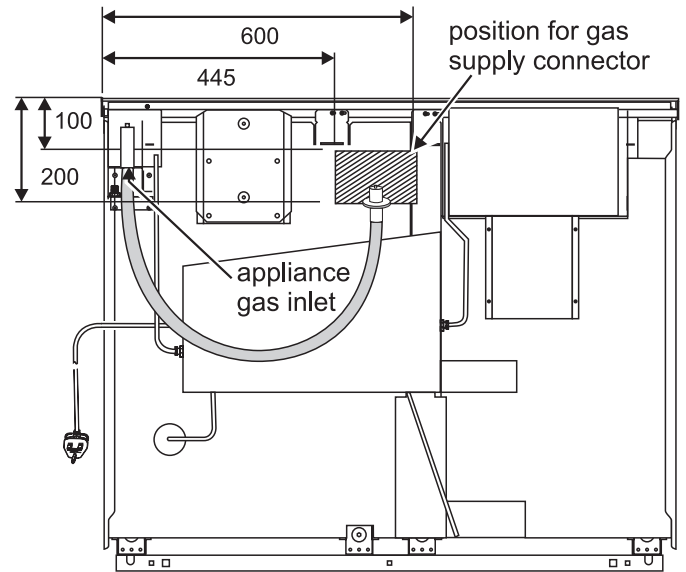

view from the rear

The Gas supply needs to terminate with a down facing bayonet. The rear cover boxes limit the position of the supply point.

Because the height of the cooker can be adjusted and each connection is different it is difficult to give precise dimensions. Ideally the house supply bayonet should be in the shaded area shown in the diagram. Although a 900mm hose can be used, a 1250mm hose will allow slightly more flexibility in the positioning of the bayonet and make moving the cooker easier. The hose should be fitted so that both inlet and outlet connections are vertical so that the hose hangs downwards.

The connector is located just below the hotplate level at the rear of the cooker.

The inlet connection on the cooker is ISO 7-1 internal. If you require a ISO 228-1 connection, find the ISP 228-1 connector in the top pack. Apply a suitable thread sealing compound to the ISO 7-1 end.

Screw the connector into the cooker inlet until it is finger tight. Using two suitable tools, one on the inlet on the cooker to make sure it is held steady and one on the connector, tighten the connector into the inlet on the cooker.

Minimum torque 12Nm.

Maximum torque 20Nm.

Connect the hose to the connector.

IMPORTANT

Flexible hose must be suitable for 70°C rise when the supply connection is above 610mm from the floor. For LPG, a suitable hose for the gas type and pressure must be used.

If in doubt contact, your supplier.

Screw connect the threaded end of the hose into the gas inlet in the underside of the connector block on the back of the cooker.

After completing the gas connection, check the cooker is gas sound with a pressure test. When checking for gas leaks do not use washing up liquid - this can corrode. Use a product specifically manufactured for leak detection.

Pressure testing

The gas pressure can be measured at one of the hotplate burner jets (NOT a Wok burner). Make sure that the cooker is not connected to the electricity supply. Lift off a burner head. Fit the pressure gauge to the jet. Turn on one of the other burners and light it with a match. Turn on the control for the hotplate burner to which the pressure gauge is fitted. Press in the knob to allow the gas through and register the pressure on the gauge.

For Natural Gas cookers the pressure should be 20mbar/25mbar

For LP Gas cookers the pressure should be 28/30mbar for Butane
37mbar for Propane.

Reassemble burner top, making sure it is reassembled in the correct way on the burner body.

Electrical Connection

WARNING: THIS COOKER MUST BE EARTHED.

All external wiring must comply with the Regulations in force and any regulations for the Electrical Equipment of Buildings. Connection to the electrical supply can be made with either a plug and socket or be permanently wired via a double pole switch. The cooker is supplied with a 3 core cable 2m long. If a replacement cable is fitted it must be 250v high temperature PVC (85°C), 1mm². Should the plug not fit the socket in your home, it should be removed and replaced with a suitable plug. Note: If a plug is fitted which is not suitable, it must be cut off and disposed of properly. To avoid the risk of electrocution, the plug must not be left where children might find it and plug it into a supply socket.

IMPORTANT The wires in the mains lead are coloured in accordance with the following code:-

GREEN AND YELLOW: EARTH

BLUE: NEUTRAL

BROWN: LIVE

Electrical checks

EARTH CONTINUITY CHECK

The cooker must be disconnected from the power supply. Set your meter to Ω (ohm) on the X1 scale and

adjust to zero if necessary.

Test the leads from any of the cooker's earth points (e.g. inside electric box cover) - to the earth pin on the cooker's plug - resistance should be less than 1 Ω (ohm). If it is not, check all the earth wires for continuity. Check that all contacts are clean and tight. Re-check. If the resistance is still greater than 1 Ω (ohm) there may be a problem, consult a qualified electrical engineer.

POLARITY CHECK

The cooker must be connected to the power supply. Your meter should be set on 300V ac scale.

Test at the cooker terminal block:

1. Test leads from L to N. Your meter should read approx. 220-240V ac.
2. Test leads from L to E. Your meter should read approx. 220-240V ac.
3. Test leads from N to E. Your meter should read approx. 0-15V ac.

If the readings are different from these values there is an electrical fault. Rectify any fault and repeat the test. If necessary repeat the test at the supply system socket/spur - if the fault also occurs at this stage then there is a house system fault which requires attention by the Electrical Authority.

The customer should be warned NOT to use the appliance until this examination has been carried out.

Hotplate check

Check each burner in turn. Each burner has a flame safety device (FSD) that stops the flow of gas to the burner if the flame goes out.

For each burner, press ignition switch on facia panel and push in and turn the knob to the solid flame symbol (♠).

Keep holding the knob pressed in to let the gas through to the burner for few seconds. If, when you let go of the control knob, the burner goes out, the safety device has not held in. Turn the control to the off position and wait one minute, then try again this time holding in the control knob for slightly longer.

Grill check

Open the grill compartment door.

There is an FSD which stops the flow of gas to the grill if the flame goes out. Turn the knob to the large flame symbol (♠). Press in the grill knob. This lets gas through to the burner. Keep holding the knob pressed in and press the igniter button or light with a match. Keep holding the button for about 10 seconds

If when you let go of the control knob the burner goes out, the safety device has not held in. Turn off the grill and wait one minute then try again this time holding in the button for slightly longer.

Fitting the oven burner trim (supplied with some models only)



The loose oven burner trim hooks onto the front of the oven burner bracket.

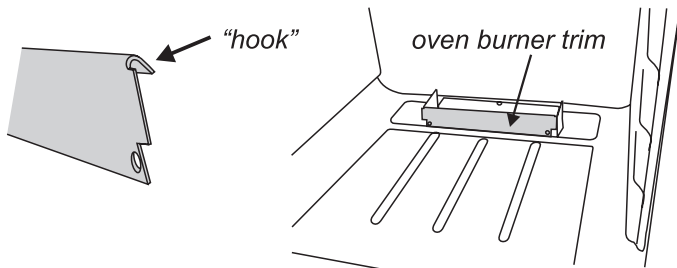

Oven check

The clock must be set to the time of day before the ovens will work.

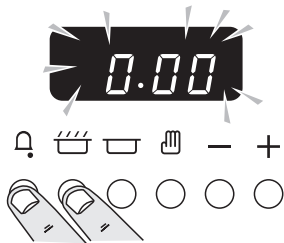

Press and hold as above.

At the same time, press - or + until the correct time shows.

Don't forget it's a 24 hour clock.

If you make a mistake or press the wrong button, turn off the power supply for a minute or two and start again.

CONTROL KNOB (THERMOSTAT) CHECK

If (AUTO) is flashing, press and release the manual (☐) button. Check each oven in turn. Push in and turn the control knob to maximum. A series of sparks will occur at the oven electrode and when the oven burner lights the sparking will stop. A small flame will appear on the oven burner, but as this flame is 'sensed' by the flame supervision device, the gas flow will come on full after a short delay. Heat each oven for 10 minutes at maximum then turn to 'S' and check that the flame size has reduced. Turn off each oven and check that the oven burner goes out.

TIMER AND SOLENOID CHECK

Automatic Operation of Timer: The gas supply to each oven can be controlled by the timer. Set a 'cooking period' time by pressing and releasing the (☐) button and using the + button to give a time of 2 minutes. By pressing and releasing the 'stop time' button (☐) the stop time is displayed. Add 3 minutes to this time by using the + button. The display will automatically change to show the time of day, the cooking symbol (☐) will go out and (AUTO) will show.

Push in and turn one of the oven knobs to maximum, the timer will run until the 'cook period' starts, when

the oven solenoid will open and the burner will light automatically. The cooking symbol (☐) will show. At the end of the 'cooking period' the solenoid will close, the oven burner will go out and the beeper will sound (the beeper may be stopped by pressing the timer (☐) button). The flashing (AUTO) symbol is a reminder to reset to manual operation. Pressing the reset' button (☐) once to stop the beep and a second time to return to manual, turn off the oven knob.

CONTROL KNOB (THERMOSTAT) CHECK

Set timer to manual. Check each oven in turn. Push in and turn the control knob to maximum. A series of sparks will occur at the oven electrode and when the oven burner lights the sparking will stop. A small flame will appear on the oven burner, but as this flame is 'sensed' by the flame supervision device, the gas flow will come on full after a short delay. Heat each oven for 10 minutes at maximum then turn to 'S' and check that the flame size has reduced. Turn off each oven and check that the oven burner goes out.

Fitting the plinth

Loosen the 3 screws along the front bottom edge of the cooker. Hook the central keyhole over the central screw. Twist and fit each end keyhole over their respective screws. Tighten the fixing screws.

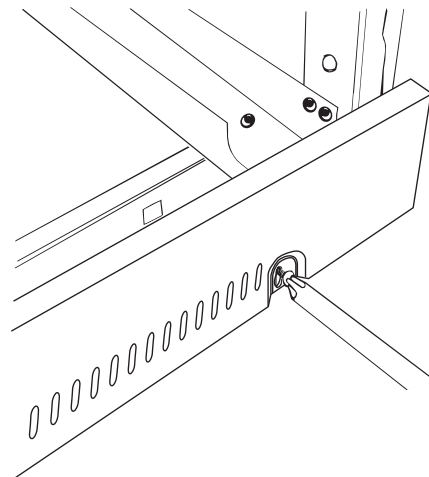

Customer care

Please complete your details in this Guide, inform the user how to operate the cooker and hand over the Instructions.

Thank you.

Circuit Diagram

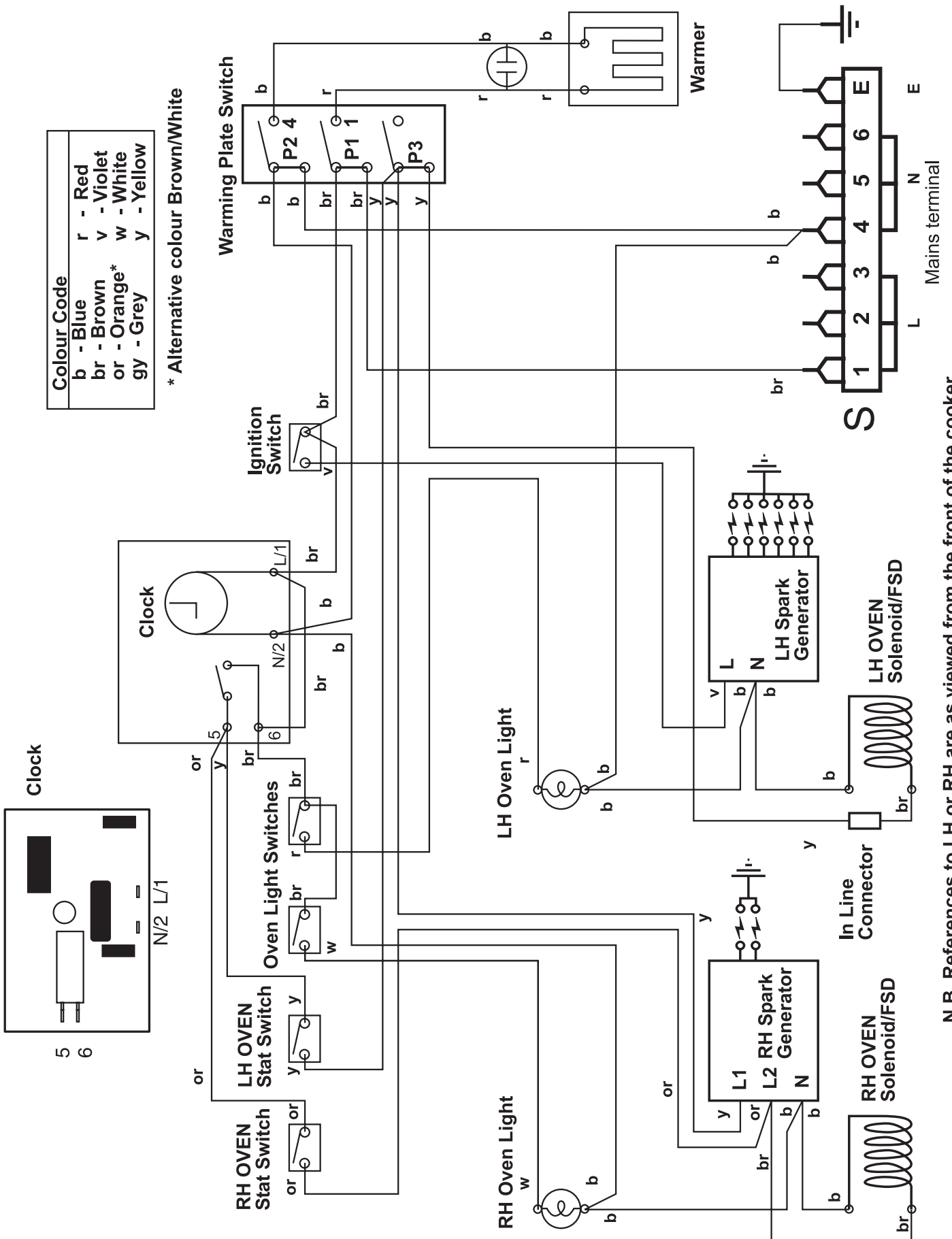

N.B. References to LH or RH are as viewed from the front of the cooker.

Technical Data

This cooker is designed for use on either :-

NATURAL GAS

ES Cat I2H G20mbar at 20mbar

ES Cat 12E+, G20 at 20mbar/G25 at 25mbar

FR/ES Cat I3+ G30 at 28mbar, G31 at 37mbar

NB: THE NATURAL GAS AND LP GAS VERSIONS OF THESE COOKERS ARE DIFFERENT MODELS AND CANNOT BE CONVERTED FROM ONE GAS FAMILY TO THE OTHER

INSTALLER: Please leave these instructions with the User.

DATA BADGE LOCATION : LOWER RIGHT HAND COOKER UPRIGHT (Remove storage drawer)

Country of Destination: GB/IE

Gas		Electric
Natural Gas	20/25mbar	220 - 240V 50Hz
Butane	28/30mbar	
Propane	37mbar	

(See appliance data badge for test pressures)

Dimensions

Overall height including optional splashback	minimum 1060mm	maximum 1090mm
Overall height	minimum 893mm	maximum 920mm
Overall width	1100mm See 'Positioning of Cooker'	
Overall depth	648mm	
Space for fixing	See 'Positioning of Cooker'	
Minimum space above hotplate	650mm	

Connections

Gas:	Electric
Rp 1/2 at rear right-hand side	220 - 240V 50Hz

Ratings

Hotplate	Natural Gas		L.P. Gas	
		Injector		Injector
Wok burner	3.5kW	internal 80	3.5kW (246g/h)	internal 54
		external 129		external 77
Large Burner	3.0kW	134	3.0kW (210g/h)	87
Medium Burners	1.7kW	109	1.7kW (119g/h)	68
Small Burner	1.0kW	75	1.0kW (70g/h)	51
Ovens	3.2kW	237	2.9kW (224g/h)	85
Grill	2.73kW	190	2.73kW (192g/h)	85

Gas burner inputs based on Gross Calorific Value

Warmer	160W
--------	------

RANGEmaster

Clarence Street, Royal Leamington Spa,
Warwickshire, CV31 2AD, England.
Tel: +44 (0) 1926 457400 Fax: +44 (0) 1926 450526
E-mail: consumers@rangemaster.co.uk
www.rangemaster.co.uk

AGA FOODSERVICE GROUP



Free Manuals Download Website

<http://myh66.com>

<http://usermanuals.us>

<http://www.somanuals.com>

<http://www.4manuals.cc>

<http://www.manual-lib.com>

<http://www.404manual.com>

<http://www.luxmanual.com>

<http://aubethermostatmanual.com>

Golf course search by state

<http://golfingnear.com>

Email search by domain

<http://emailbydomain.com>

Auto manuals search

<http://auto.somanuals.com>

TV manuals search

<http://tv.somanuals.com>