

- This product is eligible for the P2HD 5 Year Warranty Repair Program. For details, see page 8 of Vol. 1.

Operating Instructions **Vol.2**

Memory Card Camera-Recorder

Model No. **AG-HPX250P**
AG-HPX250EN

Volume **2**

Note that Operation Instructions Vol. 2 describes advanced operations of the Memory Card Camera-Recorder. For instructions on basic operations of the Memory Card Camera-Recorder, refer to Operating Instructions Vol. 1 (printed documents) contained in the supplied CD-ROM.

P2HD

AVC INTRA

DVCPROHD

DVCPRO50

DVCPRO

IN

SD HG™

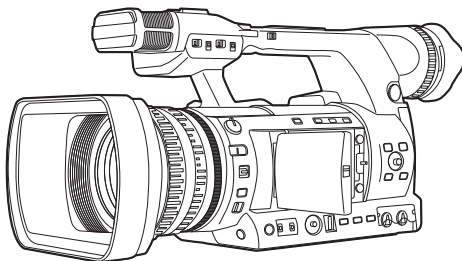

Before operating this product, please read the instructions carefully and save this manual for future use.

ENGLISH

-
- SDHC Logo is a trademark of SD-3C, LLC.
 - HDMI, the HDMI logo, and High-Definition Multimedia Interface are trademarks or registered trademarks of HDMI Licensing LLC.
 - Microsoft®, Windows®, and Windows Vista® are either registered trademarks or trademarks of Microsoft Corporation in the United States and/ or other countries.
 - Screenshots are used in accordance with Microsoft Corporation guidelines.
 - Apple®, Macintosh®, and Mac OS® are trademarks of Apple Inc., registered in the United States and other countries.
 - Other model names, company names, and product names listed in these operating instructions are trademarks or registered trademarks of their respective companies.
 - This product is licensed under the AVC Patent Portfolio License for the personal and non-commercial use of a consumer, and no license is granted or shall be implied for any use other than the personal uses detailed below.
 - To encode video in compliance with the AVC standard (“AVC Video”)
 - To decode AVC Video that was encoded by a consumer engaged in a personal and non-commercial activity
 - To decode AVC Video that was obtained from a video provider licensed to provide AVC VideoAdditional information may be obtained from MPEG LA, LLC (<http://www.mpegla.com>).

Note concerning illustrations in these instructions

- Illustrations (camera-recorder, menu screens, etc.) in these operating instructions differ slightly from the actual camera-recorder.
- In order to display the position of terminals on the camera-recorder, the protective caps included with the camera-recorder are not noted except in “Description of parts” (Page 16 of Vol. 1).

References

- References are shown as (Page 00).

Terminology

- Both SD Memory Cards and SDHC Memory Cards as referred to as “SD Memory Cards” in these operating instructions.
- Memory cards that have the “P2” logo (e.g., AJ-P2C064AG, an optional accessory) are referred to as “P2 cards” in these operating instructions.
- Video that is created during a single recording operation is referred to as a “clip” in these operating instructions.

Read this first! (For AG-HPX250P)
Read this first! (For AG-HPX250EN)
Read this first! (For AG-HPX250P/
AG-HPX250EN)
Outline of operations

Before use

Operating precautions
Precaution for use
Accessories
Optional units

Description of parts

Description of parts

Preparation

Charging the battery
Power sources
Adjusting the hand strap
Attaching the shoulder strap
Detaching and attaching the lens hood
Detaching and attaching the lens cap
Fitting the eye cup
The remote control
Turn on/off the camera-recorder
Setting the calendar
Charging the built-in battery

Menu

Using the setup menus
Setup menu structure

Reference

Specifications

Shooting

Viewfinder	6	Self-portrait shooting	35
Using the viewfinder	6	Scan reverse shooting.....	35
Using the LCD monitor	7	Zebra pattern	35
Emphasizing Image Outlines.....	7	Center marker display	36
Adjusting the screen display.....	8	Safety zone markers	36
Changing backlight brightness	8	Checking and displaying shooting status	36
Tally lamp	9	Changing the image size	37
Basic shooting operations	10	Optical Image Stabilizer	37
Preparing to shoot	10	DRS (Dynamic Range Stretcher) function.....	37
Shooting in auto mode	10	FBC (Flash Band Compensation)	38
Checking photos taken (REC CHECK)	12	Using the USER buttons	39
P2 card access lamps	12	Backlight compensation	40
Protecting against a possible erasure	12	Color bars.....	40
Formatting P2 cards	13	Waveform monitor function.....	40
P2 card recording times	14	Adjusting the volume while shooting	40
Remove the P2 card.....	15	Backup recording	40
Using SD/SDHC memory cards	16	2-slot continuous recording	41
Installing and removing the SD memory		Shot mark function	41
card	16	Text memo recording.....	42
Formatting SD memory card	16	Time stamp function	42
Cautions in using SD memory cards	17	LAST CLIP DELETE function	42
Using the zoom function	18	Using special recording modes	43
Digital zoom function	19	Pre-recording (PRE REC)	44
Shooting in progressive mode	20	Interval recording (INTERVAL REC).....	44
Standard recording		One-shot recording (ONE SHOT REC).....	45
(pull-down recording).....	20	Loop recording (LOOP REC).....	46
Native recording	20	One-clip recording (ONE CLIP REC)	47
Recording with Variable Frame Rate (VFR)	21	Adjusting the shutter speed	49
Native VFR recording	21	Using SHTR/F.RATE dial.....	49
Standard VFR recording		Setting SHUTTER mode	49
(pulldown recording).....	22	Setting SYNCHRO SCAN mode	50
Using progressive mode and VFR recording		Setting FRAME RATE mode	51
function.....	23	Switching audio input	52
Flow effect shooting.....	27	Using the built-in microphone.....	52
Shooting in manual mode	28	Using another microphone and audio	
Switching to manual mode	28	equipment.....	53
Manual focusing	28	Adjusting the audio recording level	
Using focus assist function	29	automatically	53
Iris adjustments	30	Adjusting the recording level	54
Adjusting the gain	30	CH3 and CH4 recording levels.....	55
Using super gain	31	Audio level meter magnification	55
Light intensity adjustments	31	Using scene files (Scene File Data)	56
Adjusting the white balance and black		Changing scene file settings	56
balance	32	Saving scene files and other settings on SD	
Adjusting the white balance.....	32	memory cards.....	58
Adjusting the black balance.....	34	Configuration of setup data files.....	60
Shooting techniques for different targets	35	Using time data	61
Low-angle shooting	35	Counter setting and display.....	61
		Time data overview	61
		Setting user bits.....	62

Entering the user bits	63
Setting the time code.....	66
Externally locking the time code.....	67
Outputting the time code externally.....	70
Recording time codes and user bits	71

Playback

Basic playback operations	74
Thumbnail operations	75
Thumbnail manipulations overview	76
Thumbnail screen.....	77
Selecting thumbnails	79
Playing back clips.....	79
Switching the thumbnail display	80
Changing thumbnails.....	81
Shot mark	82
Text memo.....	82
Deleting clips	84
Restoring clips.....	85
Reconnection of incomplete clips.....	85
Copying clips.....	86
Setting of clip meta data.....	87
Formatting a P2 card.....	91
Formatting SD memory cards	92
Setting the thumbnail display mode	92
Properties	93
Useful playback functions	99
Variable speed search.....	99
Slow playback	99
Fast forward/rewind playback.....	99
Frame-by-frame playback	99
Clip skip.....	100
Adjusting the volume	100
Viewing images on a TV/monitor.....	100
Checking the date and time.....	100

Editing

Connecting external units	101
Headphones	101
External microphone	101
Personal computer (non-linear editing/file transfer).....	102
Hard disk drive (data copying).....	102
Digital video equipment (Dubbing)	103
TV/Monitor (playback/dubbing)	104
Connections to the DVCPRO/DV connector.....	105
Recording signals input to the DVCPRO/DV connector.....	105
Control of external devices through 1394 connection	106
Precautions in 1394 connections	107

Nonlinear editing with P2 card (PC mode: USB device).....	109
Procedures for making connections to a personal computer.....	109

Using a hard disk drive (PC mode: USB host).....	111
Switching to the USB HOST mode.....	111
Using the USB HOST mode.....	112
Viewing hard disk drive information.....	112
Formatting a hard disk drive.....	114
Writing data on a hard disk drive.....	115
Writing data back to P2 cards.....	116
Direction for using a hard disk drive.....	117
Warning and error display for thumbnail operation and USB HOST MODE	117

Displays

Screen displays	120
Viewfinder screen status displays	120
Screen displays	121
Center information display.....	125
MODE CHECK indication.....	131

Menu

Setup menu list.....	132
SCENE FILE screen.....	132
SYSTEM SETUP screen.....	135
SW MODE screen.....	138
AUTO SW screen.....	140
RECORDING SETUP screen.....	141
AUDIO SETUP screen	143
OUTPUT SEL screen	145
DISPLAY SETUP screen.....	147
CARD FUNCTIONS screen	150
OTHER FUNCTIONS screen	151
DIAGNOSTIC screen	153
OPTION MENU screen	154

Reference

Before calling for service.....	155
Updating the firmware incorporated into the unit.....	158
Cleaning	159
Storage precautions.....	160
How to handle data recorded on P2 cards....	161
Checkpoints for using memory cards	162
Information on software for this product.....	163
Recording format list	164
Index	165

Viewfinder

This camera has two viewfinders; one is a miniature LCD in the viewfinder and the other is a retractable 3.45-type LCD.

Use the viewfinder that best suits the application and shooting conditions.

- The brightness and hue may differ between the images appearing on the viewfinder and LCD monitor and those displayed on a TV monitor. To see how the final images will appear, check them on a TV monitor.

When the LCD monitor is open, the viewfinder may not display anything. Close the LCD monitor.

Using the viewfinder

- 1 Set the POWER/MODE switch to ON and check that images appear in the viewfinder.**

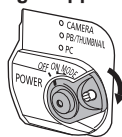

- 2 Adjust the viewfinder's angle so that the screen is positioned where it is easiest to see.**

- You can move the view finder out to about 90 degrees perpendicular to the camera-recorder.

- 3 Adjust the Viewfinder diopter dial so that you can see the characters on the viewfinder screen clearly.**

Viewfinder diopter dial

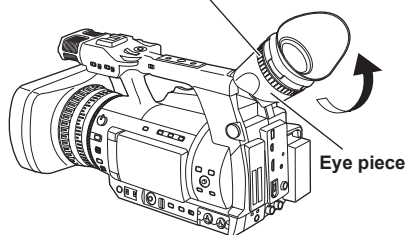

Do not point the eye piece at the sun or other strong light source.

- Light concentrated by the lens could damage internal components and poses a fire hazard.

- The pixels of the LCD monitor are controlled to obtain high precision with 99.99 % of the effective pixels. This leaves less than 0.01 % of pixels that may not light or may remain on all the time. These phenomena are normal and will have no effect on the images you shoot.
- Screen burn-in may occur in the LCD monitor. However, this is not a defect.
- The following are all viewfinder phenomena, and are not faults. Furthermore, they have no effect on recording with this camera or on output signals.
 - Primary colors (green, blue, red) may be seen in cases such as moving your line of sight within the viewfinder.
 - At low temperatures, the screen may appear with a pink tint.
 - When power is not supplied to the camera black lines may appear on the screen. These disappear when power is supplied.
- Image persistence may increase at low temperatures. This is not a fault.
- When the camera recorder is very cold, the LCD monitor is darker than normal immediately after switching the power ON. As the internal temperature increases it returns to normal.

Using the LCD monitor

1 Set the POWER/MODE switch to ON.
(Page 25 of Vol. 1)

2 Open the LCD monitor.

- It can open out to 90 degrees. Do not try to open it further as this will damage the camera-recorder.

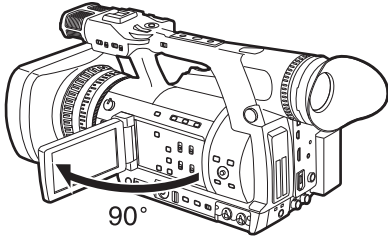

3 Position the LCD monitor where it is easiest to see.

- The monitor can be rotated 180 degrees toward the lens and 90 degrees toward you.
- **Do not apply unnecessary force to the open LCD. This can damage the camera-recorder.**

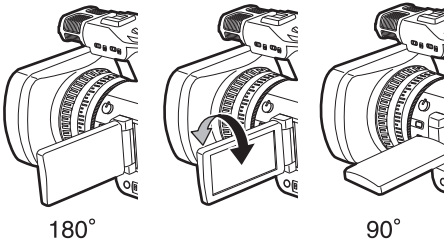

- Ensure the LCD is fully closed.

Emphasizing Image Outlines

Emphasizing outlines of images in the viewfinder and on the LCD monitor makes it easier to focus. This function does not affect video output from the camera-recorder or video recorded by the camera-recorder.

Adjust EVF PEAK LEVEL and EVF PEAK FREQ in the DISPLAY SETUP screen.

DISPLAY SETUP	
EVF PEAK LEVEL	0
EVF PEAK FREQ	LOW
EVF SETTING	>>>
EVF B. LIGHT	NORMAL
EVF COLOR	ON
EVF MODE	AUTO
ZEBRA1 DETECT	100%
ZEBRA2 DETECT	85%
PUSH MENU TO RETURN	

Viewfinder (continued)

Adjusting the screen display

1 Set the **POWER/MODE** switch to **ON**.

(Page 25 of Vol. 1)

2 Press the **MENU** button.

- For details on menu operation, refer to “Using the setup menus” (Page 28 of Vol. 1).
- You can also use the corresponding buttons on the remote control. For details, see “Description of parts” (Remote control). (Page 19 of Vol. 1)

3 Viewfinder adjustments

Select **CHANGE** under **EVF SETTING** on the setting menu **DISPLAY SETUP** screen.

LCD monitor adjustments

Set **CHANGE** under **LCD SETTING** on the setting menu **DISPLAY SETUP** screen.

• When adjusting the viewfinder

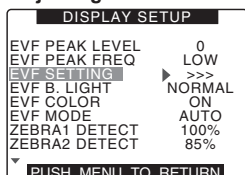

4 Push the Operation lever in the **▲** or **▼** direction to select the item.

• When adjusting the viewfinder

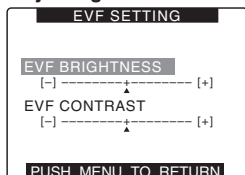

5 Push the Operation lever in the **◀** or **▶** direction to make adjustment.

• When adjusting the viewfinder

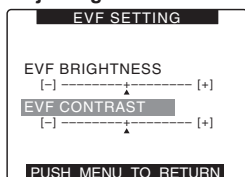

6 Press **MENU** three times to exit the menus.

- You can return the settings for **EVF SETTING** and **LCD SETTING** to the factory settings by selecting the item and pressing **COUNTER RESET** (if it is possible to change the item at that time).
- The viewfinder display can be in color or black and white. (See the setup menus, **DISPLAY SETUP** screen, **EVF COLOR**.) The resolution is the same for both of them.

Changing backlight brightness

The brightness of the LCD monitor backlight can be adjusted between five different settings.

1 Select **LCD BACKLIGHT** from the setup menu **DISPLAY SETUP** screen.

2 Select and set a value in the range of **+1** to **-3**.

The greater the value the brighter the screen.

- This setting will remain saved even if the camera-recorder's power is switched off.
 - You can cycle through **LCD BACKLIGHT** values and switch backlight brightness by pressing a **USER** button to which “**LCD B.L**” has been assigned.
- “Using the **USER** buttons” (Page 39)

Tally lamp

The tally lamp can be illuminated during recording by setting the TALLY LAMP item on the OTHER FUNCTIONS screen (Page 151) to any setting other than OFF.

When the camera-recorder is in any of the following states, the tally lamp blinks.

- When the remaining battery capacity runs out (4 blinks/sec.)
- When the available recording space on the P2 card or the battery power is low (1 blink/sec.)
- When removing the P2 card during access (4 blinks/sec.)
- When there is no recording space left on the P2 card (4 blinks/sec.)
- When there is a warning for GENLOCK IN terminal signal distortion, system error, or a recording defect. (4 blinks/sec.)

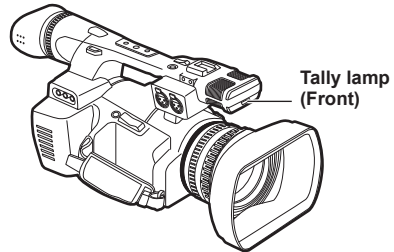
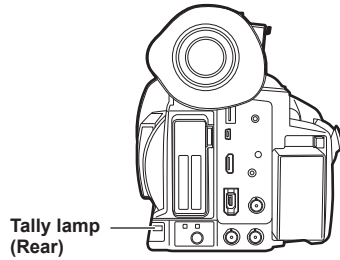

Basic shooting operations

Preparing to shoot

- 1 Set the **POWER/MODE** switch to **ON**.
(Page 25 of Vol. 1)
- 2 Push the **OPEN** lever of the P2 card slot cover downward (①) and slide to open (②).
- 3 Insert the P2 card securely in the card slot.
- 4 Raise the P2 card eject button to the direction of the arrow, and close the P2 card/SD memory card slot cover.
 - There are two card slots.
 - Be absolutely sure to close the card slot covers to keep the dust out.
 - Do not remove the P2 card while the P2 card access lamps are blinking orange. (Page 12)

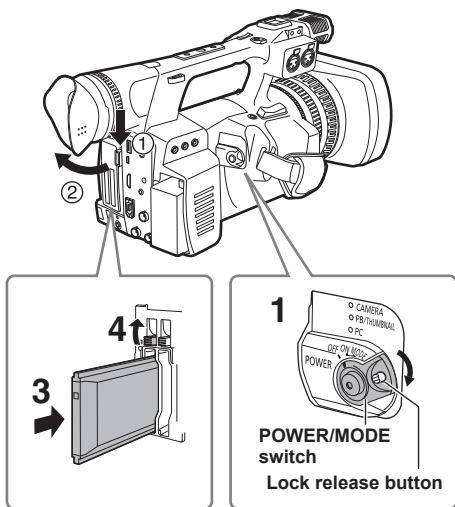

Shooting in auto mode

- 1 Set the **POWER/MODE** switch to **ON**.
(Page 25 of Vol. 1)
 - Check that the mode lamp (CAMERA) is lighted red.
- 2 Switch the **AUTO/MANUAL** switch to **AUTO** to select auto mode.
 - “A” appears on the viewfinder and LCD screens.
 - The focus, gain, iris and white balance are adjusted automatically.
- 3 Press the **START/STOP** button (Red) on the **POWER/MODE** switch to start shooting.
 - Press again to return to the camera-recorder to the shooting standby mode.
 - Use the handle START/STOP button to make it easier to shoot from low angles.
 - To prevent accidental operation, the handle side START/STOP button includes a hold mechanism.

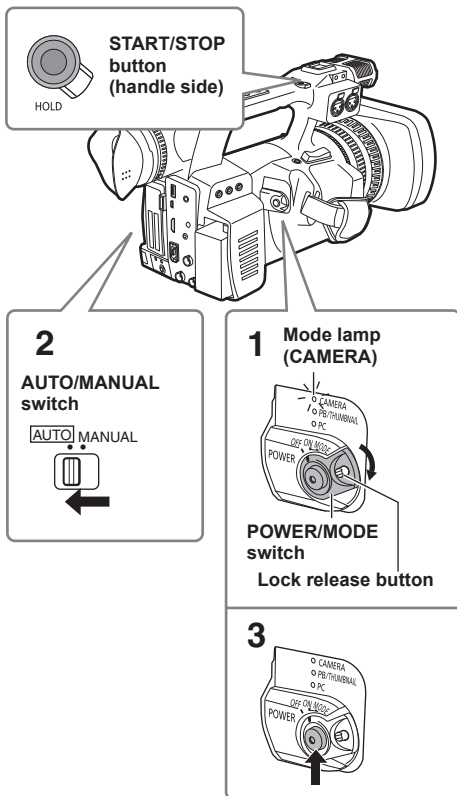

Under the following circumstances, even if you press the START/STOP button it may take some time until the writing to the P2 card finishes. For this reason, the operation will not be acknowledged if you press the START/STOP button too soon.

- Stopped after only a short recording time
 - Stopped immediately after the recording has moved to a second P2 card
-
-

Basic shooting operations (continued)

Checking photos taken (REC CHECK)

Pressing the REC CHECK button after a recording will automatically play back the last two seconds of the most recent clip.

Holding down the REC CHECK button will allow you to play back up to 10 seconds.

Use this function to check that recording is performed normally.

- The camera-recorder returns to recording standby mode after playback.
- For clips with a playback time of 10 seconds or less, clips earlier than the current clip are not played back even if the REC CHECK button is held down after returning the clip to the start.

REC CHECK button

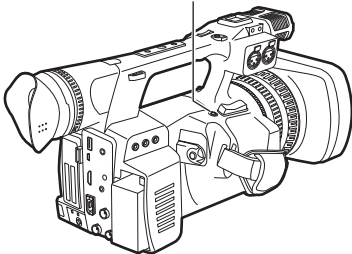

- Note that a backup recording performed on a backup device connected to the DVCPRO/ DV or SDI OUT connector will also record video played back using the REC CHECK function.
- In one-clip recording mode, the beginning of a clip is not used as the start position for playback after returning as far as possible with the REC CHECK function or starting playback while recording is paused. Instead, playback starts from the start point of the most recent recording operation.

P2 card access lamps

■ CAMERA/PB/PC (USB HOST) mode

Lights green:

Data can be saved onto the cards or loaded from them.

Blinks green (slow):

No available space on card, card is writeprotected.

Lights orange:

Slot that is the object of recording.

Blinks orange:

Data is now being accessed.

Blinks orange (fast):

A card is now being recognized.

Both lamps blink orange:

Ejection of card during access.

Off:

Cards have not been inserted or formatted.

Insertion of incompatible card.

■ PC (USB DEVICE) mode

Blinks orange:

Data is now being accessed.

Off:

A status other than access underway.

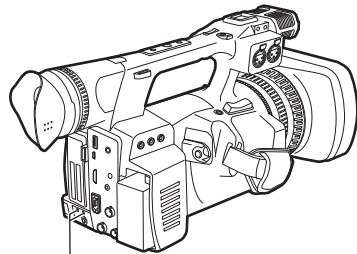

P2 card access lamp

Protecting against a possible erasure

Switch the write-protect switch of the P2 card to [PROTECT].

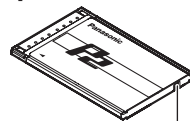

Write-protect switch



Basic shooting operations (continued)

P2 card recording times

P2 cards available to the AG-HPX250P/EN

This camera-recorder supports the optional AJ-P2C064AG (64 GB) and AJ-P2E032XG (32 GB) P2 cards, and other 4 GB to 64 GB P2 cards (as of Sep. 2011).

- **This unit cannot use AJ-P2C002SG (2 GB) cards.**
- **Depending on the type of P2 card used, you may need to update the camera-recorder driver.**
 - “Updating the firmware incorporated into the unit” (Page 158)
- **For the latest information not available in the Operating Instructions, visit the support desk at the following website.**
<http://pro-av.panasonic.net/>

P2 card recording times

(When using one 64 GB card)

System mode	Recording format (codec)	Recording time
HD (1080i, 720P)	AVC-I 100 DVCPRO HD	Approx. 64 min.
	AVC-I 50	Approx. 128 min.
SD (480i, 576i)	DVCPRO50	Approx. 128 min.
	DVCPRO DV	Approx. 256 min.

- **The above recording time is for normal recording. Recording in native mode will extend recording time depending on system mode.**
 - “Recording format list” (Page 164)
- **Use of 32 GB, 16 GB and 8 GB P2 cards will provide 1/2, 1/4 and 1/8, respectively of above recording times.**
- **The indicated capacities include a management area so the total area available for recording is somewhat smaller.**

Splitting clips recorded on P2 cards

This camera-recorder will automatically generate additional clips for a continuous recording on an 8 GB or higher capacity P2 card when the recording exceeds the durations given below. Even so, a P2 device will handle such clips as a single clip in thumbnail operations (display, delete, recover, copy, etc.). Such recordings may be handled as separate clips by nonlinear editing software or a PC.

Recording format (excluding Native format)	Continuous recording time
AVC-I 100 DVCPRO HD	Approx. 5 min.
AVC-I 50 DVCPRO50	Approx. 10 min.
DVCPRO DV	Approx. 20 min.

Remove the P2 card

- 1 Push the **OPEN lever of the P2 card slot cover downward** (①) and **slide to open** (②).
- 2 Check that the **P2 card access lamp is not blinking orange**.
- 3 Push the **P2 card eject button** and press it.
- 4 Remove the P2 card.

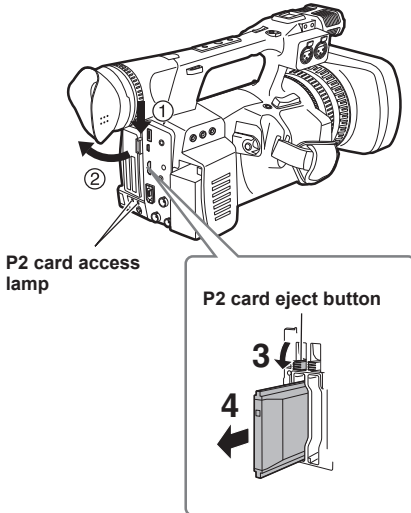

P2 card access lamp

P2 card eject button

- Do not eject the P2 card or turn the power off under the following circumstances, since doing so may cause a malfunction in the card:
 - 1 While the orange P2 card access lamp is blinking after the card is inserted (and until it stops blinking).
 - 2 During recording, during the recording finish process, or while the access lamp is blinking.

- If a P2 card is ejected during formatting or while its data is being accessed, "TURN POWER OFF" appears in the viewfinder and LCD monitor, and a warning is indicated by the tally lamp. If this happens, turn the power off and back on again.
 - When a card is ejected during formatting: Format the card again.
 - When a card is ejected while its data is being accessed: The clips may be thrown out of order. (Page 78) Check the clips and repair them. "Restoring clips" (Page 85)
- Immediately after pre-recording, a P2 card inserted into an empty slot will not be immediately recognized.
- During playback, a P2 card inserted into the empty slot will not be recognized and the P2 card access lamp will not light. When playback is completed, the P2 card recognition will begin.
- You can use ACCESS LED on the OTHER FUNCTIONS screen to set the P2 card access lamps so that they will always be off. In this case, either turn off the power or wait until enough time has passed after inserting the cards or stopping operation before ejecting the cards.
- When a P2 card is removed in PB/THUMBNAIL mode or PC mode (USB HOST), the screen is updated once it is closed. However, the system returns to the thumbnail screen no matter which screen was displayed just prior to removing the card. Furthermore, if a P2 card remains in the other slot at this time, this card will be accessed so please be careful when removing P2 cards consecutively.

Cautions in using P2 cards

Before using a P2 card, be sure to format it with a P2 device.

Using SD/SDHC memory cards

You can use SD and SDHC memory cards (the term “SD memory card” is used for both hereafter) to save and load SCENE files and USER files, and to upload clip meta data. (Page 58)

Installing and removing the SD memory card

Installation

- 1 Push the OPEN lever of the P2 card slot cover downward (①) and slide to open (②).
- 2 Insert the card while making sure it is oriented in the proper direction.

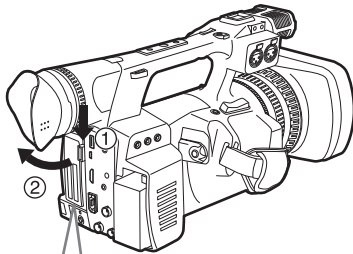

Access lamp

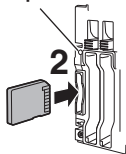

- 3 Close the P2 card/SD memory card slot cover.

Removal

- 1 Open the P2 card/SD memory card slot cover, and check that the access lamp is not lit.
- 2 Press the card further into the unit, grasp the card, and then remove.
- 3 Close the P2 card/SD memory card slot cover.

Formatting SD memory card

- 1 Set the POWER/MODE switch to ON.
(Page 25 of Vol. 1)
- 2 Turn the POWER/MODE switch to set to PB/ THUMBNAIL mode (PB/THUMBNAIL lamp illuminates).
- 3 Press the MENU button.
- 4 On the thumbnail menu, select OPERATION, FORMAT and then SD CARD. (Page 91)
 - Select EXIT to cancel the formatting.

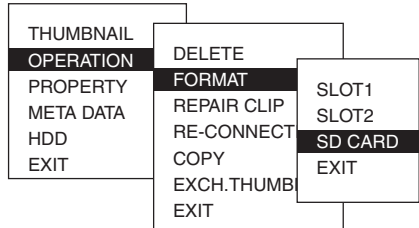

- 5 Select YES on the confirmation screen.
 - The selected SD memory card is formatted.

-
- You can also format from the SD CARD FORMAT option on the setting CARD FUNCTIONS screen. (Page 150)
 - With SDHC cards, 32 KB of capacity will have been used.
-

Cautions in using SD memory cards

SD memory cards used with the AG-HPX250P/EN should conform to SD or SDHC standards.

Be sure to format cards using the AG-HPX250P/EN.

SD memory cards with the following capacity can be used for the AG-HPX250P/EN.

SDXC memory cards are not available for this product.

SD (from 8 MB to 2 GB)

SDHC (from 4 GB to 32 GB)

For the latest information not available in the Operating Instructions, visit the P2 Support Desk at the following Web sites.

<http://pro-av.panasonic.net/>

- SD memory cards must not be used or stored in an environment where they may be
 - **Exposed to high temperatures/humidities;**
 - **Exposed to water droplets; or**
 - **Electrically charged.**
- Be sure always close the cover when using an SD memory card.
- See also “Checkpoints for using memory cards” (Page 162).

Using the zoom function

This camera-recorder has a 22 x optical zoom function.

Zoom with the zoom lever or the zoom ring.

Zoom lever (handle side)

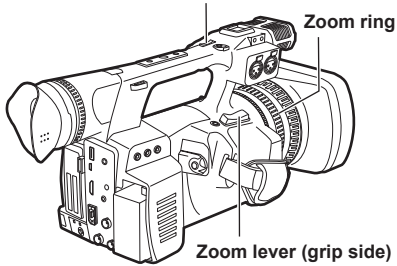

Zoom lever (grip side)

HANDLE ZOOM switch

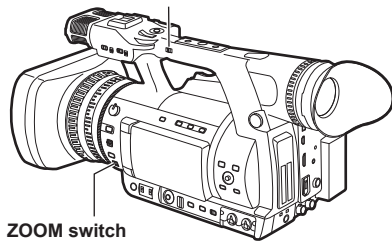

ZOOM switch

Zoom lever

Set the ZOOM switch to SERVO so that you can use the motor-driven zoom.

T : Zoom in

W : Zoom out

Gently press the zoom button on the grip to zoom slowly, firmly press to zoom faster.

Zoom lever (handle side)

You can change the zoom speed on the handle zoom button by selecting one of three speeds with the HANDLE ZOOM switch.

Set the HANDLE ZOOM switch speeds by going to the setup menus, SW MODE screen HANDLE ZOOM. (Page 138)

Zoom ring

Set the ZOOM switch to MANUAL so that you can use the zoom ring.

- You cannot use the zoom ring if the ZOOM switch is set to SERVO. Trying to use it could damage the camera-recorder.

On the remote control

Press ZOOM/VOL to zoom with the motor drive.

- Zoom speed is fixed at medium.

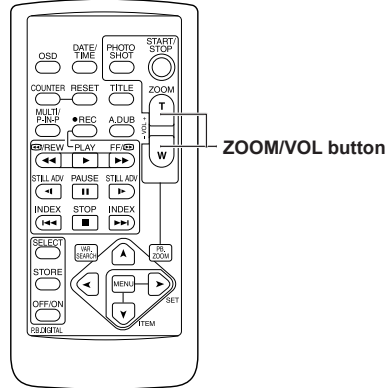

ZOOM/VOL button

Digital zoom function

Assign the D.ZOOM function to USER MAIN or any of the USER 1 – 4 buttons to enable use of the digital zoom. (Page 39)

Each press of the USER button to which D.ZOOM is assigned switches the zoom ratio in the following order: OFF (x1) → x2 → x5 → x10 → OFF (x1).

- The viewfinder and the LCD monitor indicate the zoom ratio when a setting other than OFF (x1) is selected.
- “Using the USER buttons” (Page 39)

Please take note of the following points regarding use of the digital zoom function.

- Digital zoom is not available when the DRS (dynamic range stretcher) function (Page 133) or the SCAN REVERSE function (Page 136) is running.
 - The FBC (flash band compensation) function (Page 38) is not available when the digital zoom function is running. The FBC function becomes available again when digital zoom is switched back to OFF.
 - Operating the DRS function or SCAN REVERSE function when the digital zoom function is running switches the digital zoom function off.
-

Shooting in progressive mode

In 1080i and 480i (576i) mode, this unit can perform progressive shooting when CAMERA MODE of the setting menu is set to 24P, 24PA, or 30P (25P).

When performing progressive shooting, the recording format can be set to native (which uses the camera's shooting frame rate as is) or standard (which pulls the frame rate down to 59.94 (50)).

Standard recording (pull-down recording)

24P records with 2:3 pulldown and 30P (25P) records with 2:2 pulldown, and both record as 59.94i (50i).

The camera-recorder can also handle video shot in the 24PA mode (2:3:3:2 advanced pulldown).

Note that AVC-Intra does not support pulldown recording.

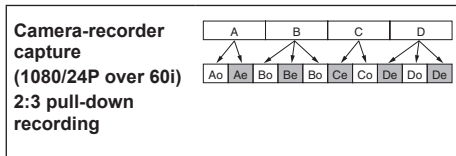

Native recording

This format extracts and records only effective frames when 1080i mode is used with 24PN or 30PN (25PN) AVC-Intra mode.

Furthermore, native recording format for both DVCPRO HD and AVC-Intra is supported with 720P, enabling recording of 2 – 2.5x longer than pull down recording.

Also in native recording, the output of camera-recorder video and playback video is a 59.94 (50) frame rate.

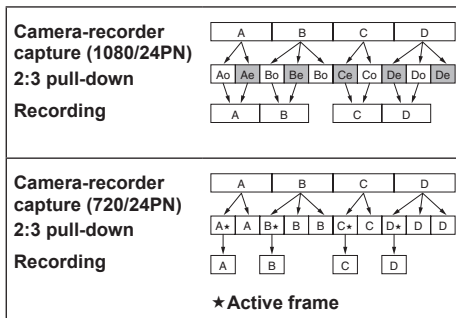

- In 24P/24PA, 24PN (native recording) and in 30PN/25PN (native recording) at 720P, the camera starts recording in 5-frame, 4-frame and 2-frame segments, respectively. For this reason, to continue recording clips in a system mode using a different recording segmentation may break the continuity of the time code.
- The camera uses internal memory for recording, when recording starts as soon as a P2 card is inserted or the camera is powered up. In this situation, recording cannot be stopped until P2 card recognition ends. To check P2 card status, press the DISP/ MODE CHK button and check the row for SLOT 1 and 2 displayed in the viewfinder or LCD monitor.
- An editing system that supports 24PA (2:3:3:2 advanced pulldown) will enable editing with less quality loss than 24P (2:3 pulldown).
- Record at standard 24P if a 24PA compatible editing system will not be used.

Recording with Variable Frame Rate (VFR)

In 1080i and 720P mode, this unit can shoot using frame skipping (under cranking) and high speed recording (over cranking). You can select native (PN) recording mode and standard (OVER) recording.

Native VFR recording

1 In 1080i or 720P mode, set REC FORMAT on the setting menu SYSTEM SETUP screen to AVC-I 100/24PN (or 30PN, 25PN).

2 In the SCENE FILE screen, set the menu option VFR to ON and the menu option FRAME RATE to suit shooting purposes.

You can also change the frame rate using the SHTR/F.RATE dial.

- “Setting FRAME RATE mode” (Page 51)

3 Press the START/STOP button.

This starts recording in the VFR mode (native VFR).

This mode can be combined with the AVC-I 100, AVC-I 50, 30PN (25PN), and 24PN recording formats.

You can also select DVCPRO HD with 720P.

- “Setting FRAME RATE mode” (Page 51)
- “SYSTEM SETUP screen” (Page 135)

Note the following about native VFR recording.

- Pre-recording, loop recording, interval recording, one-shot recording, and one-clip recording are not available.
- 1394 output is not available during recording and recording standby.
- Changing Scene Dial position during recording does not change VFR on and off position.
- Sound cannot be recorded.*1

At this time, no audio is output and “A. REC” is displayed over the audio level meter. “VFR ON, NO AUDIO RECORDING” is also displayed when recording starts.

- The time code is locked to Rec Run.*1
- Thumbnail screens are created 1 frame later than video recorded on a P2 card, but this is not a malfunction.
- The screen may be distorted when changing the FRAME RATE setting.
- Gain is fixed to 0 dB when set to 4 frames or less.

Furthermore, AGC, auto iris, auto focus, and ATW do not function and must be operated manually.

- Red, blue, or green points may appear on the screen when the frame rate is low. This is not a fault.

*1 In 24PN/30PN (25PN) recording modes, when the frame rate is 24 and 30 (25) frames per second, respectively, audio can also be recorded. The time code can be set to Free Run (F-RUN).

Recording with Variable Frame Rate (VFR) (continued)

Standard VFR recording (pulldown recording)

1 In 1080i or 720P mode, set REC FORMAT on the setting menu SYSTEM SETUP screen to AVC-I 100/60i (60P) (or 50i, 50P).

2 In the SCENE FILE screen, set the menu option VFR to ON and the menu option FRAME RATE to suit shooting purposes.

You can also change the frame rate using the SHTR/F.RATE dial.

- “Setting FRAME RATE mode” (Page 51)

3 Press the START/STOP button.

This starts recording in the VFR mode (pulldown recording).

This mode can be combined with the AVC-I 100/60P (50P), AVC-I 50/60P (50P) 30PN, and DVCPROHD/60P (50P) recording formats in 720P system mode, and AVC-I 100/60i (50i), AVC-I 50/60i (50i), DVCPROHD/60i (50i) in 1080i system mode.

- “Setting FRAME RATE mode” (Page 51)
- “SYSTEM SETUP screen” (Page 135)

- With AVC-Intra or DVCPRO HD in 1080i, clips are recorded as 60i, 60P (50i, 50P) with pull down information not recorded.
- Audio playback is disabled when a frame rate converter is used to extract active frames for over and under-cranking.

Note the following about standard VFR recording.

- Pre-recording, loop recording, interval recording, one-shot recording, and one-clip recording are not available.
 - 1394 output is available during recording and recording standby, but not in AVC Intra mode.
 - Changing Scene Dial position during recording does not change VFR on and off position.
 - Sound is recorded.
 - The screen may be distorted when changing the FRAME RATE setting.
 - Gain is fixed to 0 dB when set to 4 frames or less.
Furthermore, AGC, auto iris and ATW do not function and must be operated manually.
 - Red, blue, or green points may appear on the screen when the frame rate is low. This is not a fault.
-

Using progressive mode and VFR recording function

Standard speed for film production

Screen production normally requires a 24 fps (24 frames per second) frame rate (normal speed) for screening a film. Making the settings described below will provide film-quality playback. The 720P progressive mode and cine-like gamma will make video look like it was shot with a film camera-recorder.

Standard settings for film production

SYSTEM MODE settings			Recording frame rate
SYSTEM MODE	Other settings		
720-59.94P	REC FORMAT	AVC-I 100/24PN (AVC-I 50/24PN) (DVCPROHD/24PN)	24 frames
	VFR	OFF	
1080-59.94i	REC FORMAT	AVC-I 100/24PN (AVC-I 50/24PN) (DVCPROHD/60i)	
	CAMERA MODE ^{*1}	24P, 24PA	
	VFR	OFF	

*1: Only when the menu option REC FORMAT is set to DVCPROHD/60i in the SYSTEM SETUP screen.

Recording with Variable Frame Rate (VFR) (continued)

Shooting at standard speed for producing commercials and TV programs

When producing videos for display on a television screen such as HDTV/SDTV broadcast, a frame rate of 30 fps (30 frames per second), 25 fps (25 frames per second) for 50 Hz, is standard (x1). The settings below allow you to obtain the kind of playback used for broadcast programs. This permits film-like video recording of commercials and music clips that also provide a frame rate suitable for broadcasting.

Standard settings for producing commercials and dramas

SYETEM MODE settings			Recording frame rate
SYSTEM MODE	Other settings		
720-59.94P	REC FORMAT	AVC-I 100/30PN (AVC-I 50/30PN) (DVCPROHD/30PN)	30 frames
	VFR	OFF	
1080-59.94i	REC FORMAT	AVC-I 100/30PN (AVC-I 50/30PN) (DVCPROHD/60i)	
	CAMERA MODE*1	30P	
	VFR	OFF	
720-50P	REC FORMAT	AVC-I 100/25PN (AVC-I 50/25PN) (DVCPROHD/25PN)	
	VFR	OFF	
1080-50i	REC FORMAT	AVC-I 100/25PN (AVC-I 50/25PN) (DVCPROHD/50i)	
	CAMERA MODE*1	25P	
	VFR	OFF	

*1 Only when the menu option REC FORMAT is set to DVCPROHD/60i (50i) in the SYSTEM SETUP screen.

Undercranking effects

This effect produces the quick motion often used for showing clouds drifting across the sky, crowds of people swarming past a solitary standing individual, a kung fu demonstration and other performances. For example, selecting a VFR recording frame rate of 12 fps when shooting at a 24P recording format yields a fast-motion effect of approx. 2x normal speed.

Standard setup for undercranking effects

SYSTEM MODE settings			Recording frame rate
SYSTEM MODE	Other settings		
1080-59.94i	REC FORMAT	AVC-I 100/24PN (AVC-I 50/24PN)	1 to 22 frames
	VFR	ON	
	FRAME RATE	Set to 23 frames or less	
1080-50i	REC FORMAT	AVC-I 100/25PN (AVC-I 50/25PN)	1 to 24 frames
	VFR	ON	
	FRAME RATE	Set to 24 frames or less	
720-59.94P	REC FORMAT	AVC-I 100/24PN (AVC-I 50/24PN) (DVCPROHD/24PN)	1 to 22 frames
	VFR	ON	
	FRAME RATE	Set to 22 frames or less	
720-50P	REC FORMAT	AVC-I 100/25PN (AVC-I 50/25PN) (DVCPROHD/25PN)	1 to 24 frames
	VFR	ON	
	FRAME RATE	Set to 24 frames or less	

- With the menu option REC FORMAT set to DVCPROHD/60P (50P), you can use a nonlinear editing system to generate quick motion effects from the resulting footage.

Recording with Variable Frame Rate (VFR) (continued)

Overcranking effects

Overcranking produces slow-motion playback, which is frequently used in climax scenes, or for dramatic effects like car chases and action scenes. For example, selecting a recording frame rate of 60 fps when shooting a 24P recording format yields a slow-motion effect that is 2.5 times normal speed. Shooting 720P progressive video will produce smooth and highquality slow-motion.

Furthermore, with 1080i, a slow motion effect of 1.25 can be gained if you set the recording frame rate to 30 fps when recording was performed using 24P, a recording format for specifying the playback frame rate.

Standard setup for overcranking effects

SYSTEM MODE setup			Recording frame rate
SYSTEM MODE	Other settings		
1080-59.94i	REC FORMAT	AVC-I 100/24PN (AVC-I 50/24PN)	25 to 30 frames
	VFR	ON	
	FRAME RATE	Set to 25 frames or more	
720-59.94P	REC FORMAT	AVC-I 100/24PN (AVC-I 50/24PN) (DVCPROHD/24PN)	25 to 60 frames
	VFR	ON	
	FRAME RATE	Set to 25 frames or more	
720-50P	REC FORMAT	AVC-I 100/25PN (AVC-I 50/25PN) (DVCPROHD/25PN)	26 to 50 frames
	VFR	ON	
	FRAME RATE	Set to 26 frames or more	

- With the menu option REC FORMAT set to DVCPROHD/60P (50P), you can use a nonlinear editing system to generate slow motion effects from the resulting footage.
- A slow motion effect cannot be gained if SYSTEM MODE is set to 1080-50i and REC FORMAT is set to AVC-I***/25PN.

Flow effect shooting

This way of shooting provides a flow effect and may, for instance, be used to shoot a subject on a far side of a road with a stream of fast-moving cars as the flow, in such a way that the stationary subject comes into focus through the cars.

- 1 Set SYSTEM MODE on the setting menu SYSTEM SETUP screen to 1080-59.94i (50i), REC FORMAT to AVC-I 100 (50)/60i (50i) or DVCPRO HD/60i (50i), and VFR to ON.**

Set FRAME RATE to a low value suitable for the shooting purpose.

Setting can be performed in the same way for 720P.

- 2 Press the START/STOP button.**

This starts recording in the VFR mode.

During flow effect shooting - general notes

- Please take note of the following points when selecting AVC-Intra recording.
 - When 1080i is selected, the image signal and HD SDI output signal recorded are 60i (50i) and all frames are effective frames.
 - With both 1080i and 720P, pull down information is not attached to recorded clips.
When you wish to use this information, select DVCPRO HD mode with 720P.
- Audio recording will be recorded onto P2 card at all frame rates.
- Fixed shutter and synchro scan are valid.

Shooting in manual mode

Set the unit to manual mode when manually adjusting the focus, iris, gain and white balance.

Switching to manual mode

Slide the AUTO/MANUAL switch to MANUAL to switch to the manual mode.

(**A** on the viewfinder and LCD go out.)

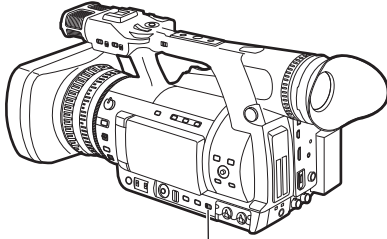

AUTO/MANUAL switch

Manual focusing

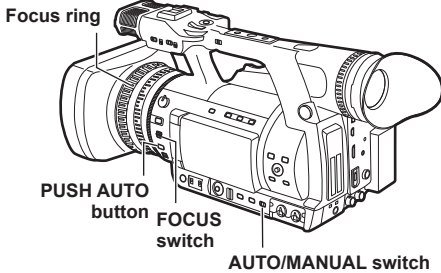

1 Use the AUTO/MANUAL switch to switch to manual mode.

2 Use the FOCUS switch to choose how to control focusing.

A (AUTO): (Auto focus mode)

Adjusts focus automatically.

M (MANUAL): (Manual focus mode)

Turn the focus ring by hand.

∞ :

The camera-recorder first focuses on infinity, then it switches to manual focus.

The FOCUS switch automatically moves back to M (MANUAL) after you move it to ∞ .

Temporarily switching to auto focus

Even if you have switched FOCUS to M (MANUAL) the camera-recorder will focus automatically while you press down PUSH AUTO.

Switching to manual focus assist mode

To change from the manual focus mode to the manual focus assist mode, set MF ASSIST to ON on the setting menu SW MODE screen.

- You can make coarse adjustments to the focus in manual focus assist mode by turning the focus ring about half the amount you would turn it in manual focus mode.
 - Fine adjustment is made automatically after you operated the focus ring.
 - If the focus differs considerably from the manually set focus, the focus may not be set correctly.
 - Automatic adjustment is not performed until you operate the focus ring for the next time.
-
- Auto focus may not work properly if there is flickering. Select a shutter speed suited to the ambient light. (Page 49)
 - If the auto focus mode is set with any format except 60i (50i) and 60P (50P), controlling the focus will take slightly longer than in the normal focus mode.
 - If you have set ON for the AF item on the setting menu AUTO SW screen, auto focusing will occur regardless of the position of the FOCUS switch when the auto mode has been established. (Page 140)
 - When the display is set to macro shooting, the screen display for "AF", "MF", and "MA" is reversed black and white characters.

Using focus assist function

Pressing the FOCUS ASSIST button magnifies the image at the center to facilitate focusing.

Set the menu option FOCUS BAR to ON in the DISPLAY SETUP screen to display the focus bar.

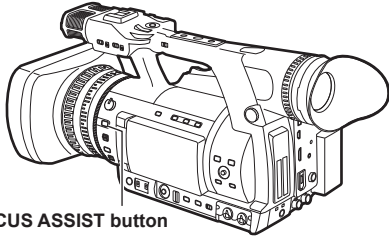

FOCUS ASSIST button

This function magnifies only the image at the center of the LCD monitor and viewfinder. It is not superimposed on signals output via the VIDEO OUT, SDI OUT and HDMI OUT connectors.

EXPANDED: (FOCUS ASSIST button)

Trebles the size of the center of the image.

The status indication and the zebra pattern disappears and EXPANDED appears at the top of the screen.

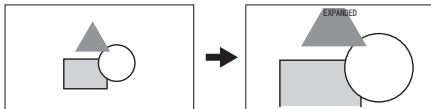

- The EXPANDED display is available only during recording and does not work in external input mode.

In VIDEO OUT, SDI OUT, and HDMI OUT, the center of the image is not magnified and status indications do not appear.

FOCUS BAR: (DISPLAY SETUP menu)

The length of the bar indicates whether the image is in focus.

The focus bar extends to the far right when the image is in focus.

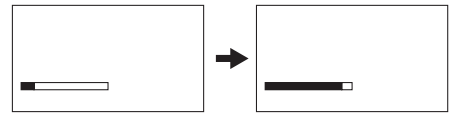

Out of focus

The bar extends to the right when the image is in focus.

Iris adjustments

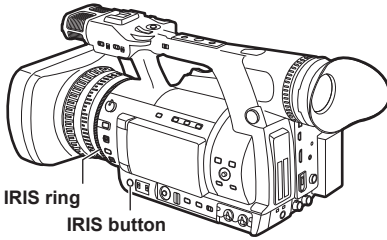

- 1** If the camera-recorder is in auto mode, use the **AUTO/MANUAL** switch to switch to manual mode. (Page 28)
- 2** Press the **IRIS** button to switch how to adjust the aperture of lens.
AUTO IRIS:
Adjust the iris automatically.
MANUAL IRIS:
Adjust the iris manually.
- 3** Turn the **IRIS** ring to adjust the aperture of lens when in the manual iris mode.
In the auto iris mode, the lens iris can be corrected using this ring.

If you have set ON under A.IRIS on the setting menu AUTO SW screen, auto iris will be forcibly selected when auto mode has been established. (Page 140)

-
- This unit's iris F number when it is open is F1.6 at full WIDE and F3.2 at full TELEPHOTO. The iris display in the viewfinder or on the LCD when the iris is open is OPEN at full WIDE and F3.2 or OPEN at full TELEPHOTO.
 - You can display the brightness level for the center part of the screen by pressing a **USER** button (Page 39) to which **Y GET** has been assigned.
-

Adjusting the gain

When the display is dark, increase the gain to brighten the display.

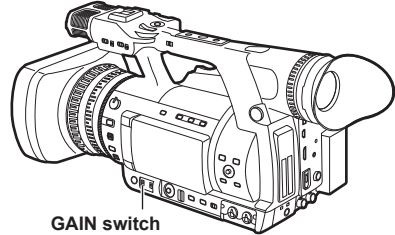

- 1** If the camera-recorder is in auto mode, use the **AUTO/MANUAL** switch to switch to manual mode. (Page 28)
- 2** Switch the gain with the **GAIN** switch.
L: Set here under normal conditions. (The default value is 0 dB.)
M: Increase the gain of the image amplifier. (The default value is 6 dB.)
H: Increase the gain of the image amplifier. (The default value is 12 dB.)

You can change each L, M and H gain values using the **LOW GAIN**, **MID GAIN** and **HIGH GAIN** items on the setting menu **SW MODE** screen. (Page 138)
In auto mode, auto gain is available regardless of the **GAIN** switch setting when a setting other than **OFF** is selected under **AGC** on the setting menu **AUTO SW** screen. (Page 140)

In variable frame rate (VFR) mode, gain is fixed to 0 dB when the frame rate is set to 4 frames or less.

Using super gain

You can increase the gain level further when shooting in dark space.

Set SUPER GAIN on the setting menu SW MODE screen to 24 dB, 30 dB or BOTH.

Cycles to the next value in the order 24 dB → 30 dB → OFF when pressing USER button in BOTH.

You can switch to the selected gain by pressing a USER button to which S GAIN has been assigned.

- “Using the USER buttons” (Page 39)
- In variable frame rate (VFR) mode, super gain is not available when the frame rate is set to 4 frames or less.
- AGC is not available when super gain is selected, even if AUTO/MANUAL is set to AUTO.

Light intensity adjustments

Use the ND FILTER dial to change the ND Filter used (filter to change light intensity).

OFF: ND filter is not used.

1/4: Cuts light intensity by up to about 1/4.

1/16: Cuts light intensity by up to about 1/16.

1/64: Cuts light intensity by up to about 1/64.

ND FILTER dial

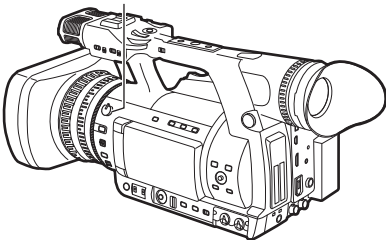

Adjusting the white balance and black balance

To record high-quality video with the AG-HPX250P/EN, the black and white balances must be adjusted according to conditions.

If white balance and black balance adjustments are made while the video image is distorted due to GENLOCK, the adjustments may not be correct. Wait for the video image to return to normal before performing white balance and black balance adjustments again.

Adjusting the white balance

Whenever light conditions change, the white balance must be readjusted.

To adjust the white balance, follow the steps on the right.

ND FILTER dial

This control adjusts the amount of light entering the MOS sensor.

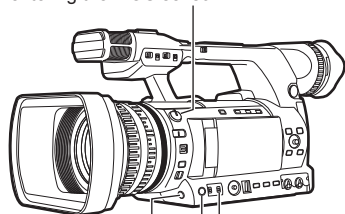

AWB button

Use for automatic control of white balance.

WHITE BAL switch

Set to A or B.

GAIN switch

Normally set to 0 dB. If this is too dark, adjust gain as necessary.

1 Set the GAIN and WHITE BAL switches.

- For the WHITE BAL switch, select A or B as a position to save the adjustment value.

2 Adjust the ND FILTER dial according to the light conditions.

For examples of ND FILTER dial, see "Light intensity adjustments" (Page 31).

3 Place a white pattern at a point where the light conditions match those for the light source of the subject. Then zoom-in on the white pattern so that white color appears in the screen.

- A white object (cloth or wall) may be used instead of a white pattern. The illustration below shows the required size for the white space.

- Do not point the camera-recorder at a high-brightness area.

- The white object must appear at the center of the screen.

1/3 or more of the screen in width

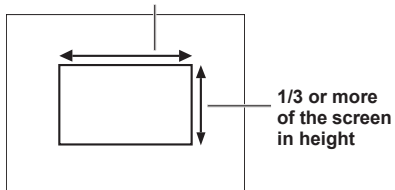

4 Adjust the lens iris.

- Use the Y GET function (Page 122) and adjust the iris to a approximately 70 % of incoming light.

5 Press the AWB button.

- The switch returns to the central position with the white balance automatically adjusted.

6 During an adjustment, the viewfinder or LCD monitor displays the following message:

AWB Ach ACTIVE

7 The adjustment will take effect in a few seconds, and the following message will appear:

- The adjusted value is automatically stored in the selected memory (A or B).

AWB A OK 3.2K

- “C TEMP+7” to “C TEMP-7” will appear when COLOR TEMP of the scene file is set to the value other than 0.

8 If the subject's color temperature is lower than 2300K or higher than 9900K the following message appears:

- If the arrow points down (↓) the actual color temperature is lower than the temperature indicated. If the arrow points up (↑) the actual temperature is higher than the temperature indicated.

AWB A OK 2.3K ↓

When you have no time to adjust the white balance

Position the WHITE BAL switch at PRST.

- You can switch between 3200 K and 5600 K by pressing the AWB button.

When the white balance has not been automatically adjusted

When the white balance has not been successfully adjusted, the viewfinder or LCD monitor displays an error message.

Error message	Description → Adjustment details
AWB Ach (or Bch) NG	The color temperature is too high or too low.
LOW LIGHT	There is insufficient light. → Increases the amount of light. Also increases gain.
LEVEL OVER	There is too much light. → Reduces the amount of light. Also reduces gain.

Viewfinder displays related to white balance

- For details on the screen display of the viewfinder, see “Screen displays” (Page 121).

Setting auto tracking white balance (ATW)

This camera-recorder is equipped with an auto tracking white balance (ATW) function that automatically adjusts the white balance of images in accordance with lighting conditions.

The ATW function can be assigned to the WHITE BAL switch B by setting the menu option ATW in the SW MODE screen to B ch.

Also, you can allocate the ATW function to USER MAIN or USER buttons 1 to 4.

- “Using the USER buttons” (Page 39)

Cancelling auto tracking white balance

Press the USER button to which ATW was assigned a second time or change the WHITE BAL switch position. If ATW was assigned to the WHITE BAL switch B, the USER button cannot be used to cancel the function.

- **This function does not provide a 100 % accurate white balance. The tracking performance relative to changes in ambient lighting and white balance performance have been given a degree of latitude.**
- **In variable frame rate (VFR) mode, ATW is not available when the frame rate is set to 4 frames or less.**

Adjusting the white balance and black balance (continued)

Adjusting the black balance

The black balance must be adjusted when:

- You use your AG-HPX250P/EN the first time.
- Your AG-HPX250P/EN has not been used for some time.
- The ambient temperature has changed substantially.
- The gain switchover value has been changed.
- The menu options SYSTEM MODE and REC FORMAT in the SYSTEM SETUP screen.

Adjust the black balance before shooting to ensure optimum video quality.

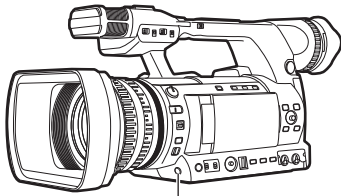

AWB button

Use for automatic control of white balance.

- During a black balance adjustment, light is automatically cut off.
- Black balance adjustment is not available during recording.
- Pressing the START/STOP button during ABB adjustment will not start recording on a P2 card.

1 Press and hold the AWB button for approximately 2 seconds.

- Black balance is adjusted after the white balance.

As white balance is adjusted first, set the conditions for white balance adjustment beforehand.

2 During adjustment, the viewfinder displays the following message:

ABB ACTIVE

3 The adjustment will take effect in a few seconds and the following message will appear:

ABB END

The adjusted value is automatically stored in the memory.

Shooting techniques for different targets

Low-angle shooting

Low-angle shooting can be performed using the handle side START/STOP button by releasing (1) the hold switch on this button from the HOLD position.

- To prevent accidental operation of the START/STOP button on the handle side when not in use, set the hold switch to HOLD.

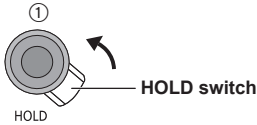

START/STOP button (handle side)

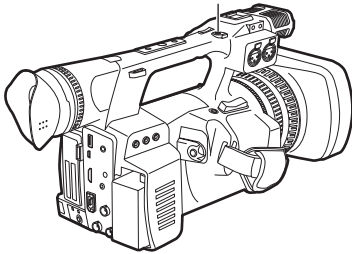

Self-portrait shooting

When shooting with the LCD display angled 180 degrees towards the lens, you can set the menu option SELF SHOOT to MIRROR, to horizontally flip the video image on the LCD display, and allow you to view a mirror image while shooting. Note that only the video image on the LCD monitor is horizontally flipped, not the actual video being recorded.

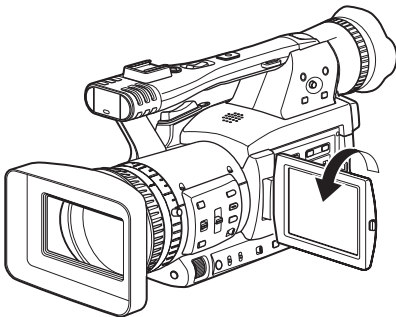

Scan reverse shooting

By setting SCAN REVERSE on the setting menu SYSTEM SETUP screen to ON, video can be vertically/horizontally inverted when displaying and recording.

Zebra pattern

The AG-HPX250P/EN can display two zebra patterns.

Turning the ZEBRA switch on displays the zebra pattern set in the menu in the viewfinder and LCD monitor. A menu setting makes it possible to also display the zebra pattern on video output via the VIDEO OUT connector.

ZEBRA button

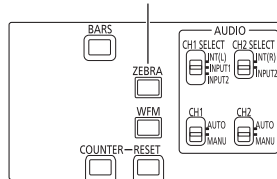

Use the DISPLAY SETUP screen to set the level of zebra pattern display. (Page 147)

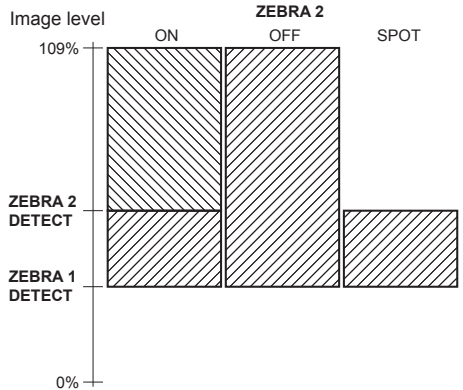

SPOT:

A video level between ZEBRA1 and ZEBRA2 displays a zebra pattern.

To display a zebra pattern on video output via the VIDEO OUT connector, make the required settings in the OUTPUT SEL screen. (Page 145)

Shooting techniques for different targets (continued)

Center marker display

A center marker is displayed when the menu option MARKER in the DISPLAY SETUP screen is set to ON. (Page 147)

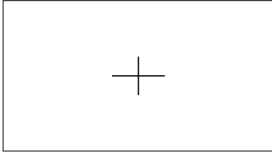

The center marker display appears only on the LCD monitor and in the viewfinder. It is not superimposed on signals output via the VIDEO OUT, SDI OUT and HDMI OUT connectors.

Safety zone markers

A safety zone marker is displayed when the menu option SAFETY ZONE is selected in the DISPLAY SETUP screen. (Page 148)

Safety zone markers appear only on the LCD monitor and in the viewfinder. They are not superimposed on signals output via the VIDEO OUT, SDI OUT and HDMI OUT connectors.

Checking and displaying shooting status

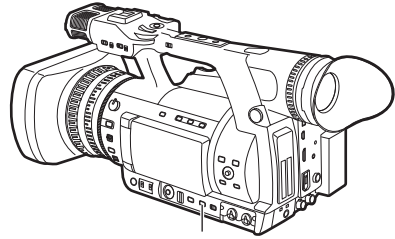

DISP/MODE CHK button

When you hold down the DISP/MODE CHK button during recording standby or recording, all the information including the setting status of the shooting functions and a list of functions allocated to the USER buttons, will be displayed. When you release the button, the normal display will be restored.

- “Using the USER buttons” (Page 39)

When you push the DISP/MODE CHK button during recording standby or recording, all the information will be unshown. When you press the button again, the normal display will be restored. The information is retained even if you turn off the unit's power or switch to another operation mode.

Changing the image size

When recording in 480i/576i mode, you can change the size (aspect ratio) of the images that you record.

Select the aspect ratio in the setup menus, SYSTEM SETUP screen, ASPECT CONV. (Page 137)

- Refer to the section "Using the setup menus" (Page 28 of Vol. 1) for menu operation.

SIDE CROP:

Recorded in the regular 4:3 aspect ratio.

The left and right edges of the image are cut.



LETTER BOX:

Recorded in the 16:9 aspect ratio.

Black bands are recorded at the top and bottom of the image.

When LETTER BOX is selected, black bands are not displayed at the top and bottom of the viewfinder or LCD monitor as the screen size is 16:9. As such, "LT.BOX" is displayed on the screen.



SQUEEZE:

The recorded images are squeezed horizontally so that they are shown as 16:9 images on a compatible wide-screen television.

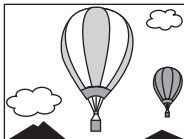

Optical Image Stabilizer

Use the Optical Image Stabilizer (OIS) to reduce the effects of camera-recorder shake when shooting by hand.

Press the OIS button to turn the function on and off.

 appears on the screen when this function is on. Turn the function off when using a tripod for more natural images.

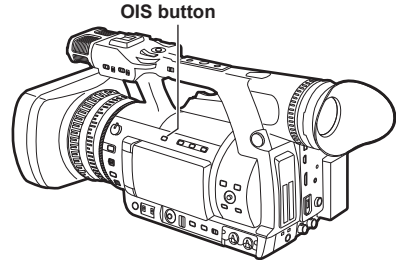

- This function will not be as effective when the vibration is severe or when tracking a moving subject.

DRS (Dynamic Range Stretcher) function

This function compresses the video signal level while maintaining contrast to extend the dynamic range making it possible to correctly render highlight areas without overexposure and loss of detail that would otherwise occur.

When using 1080i, the DRS function is not available if shooting with 24P, 30P, 25P or VFR (variable frame rate).

This function runs when DRS on the setting menu SCENE FILE screen is set to ON. (Page 133)

You can change the level of compression using DRS EFFECT. (Page 133)

You can allocate DRS ON/OFF to a USER button. (Page 39)

Shooting techniques for different targets (continued)

FBC (Flash Band Compensation)

This camera-recorder comes with a function to compensate for and minimize light band (flash band) interference that occurs with the MOS imager when shooting in an environment where flash photography is taking place.

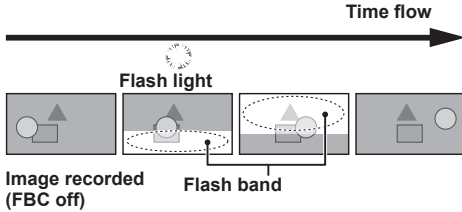

Setting FBC function

Assign the FBC function to a USER button. Press the USER button to which the FBC function has been assigned to turn it on and automatically detect and compensate for flash light from still cameras.

- “Using the USER buttons” (Page 39)

The status display indicates “FBC” when the FBC function is on. *1

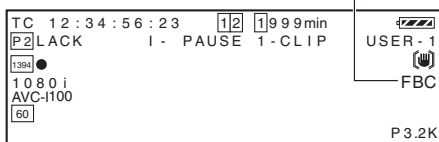

- *1 Not displayed when the menu option OTHER DISPLAY in the DISPLAY SETUP screen is set to OFF.

The following phenomena that may occur in video that includes flash light is due to FBC compensation and not indicative of a malfunction.

- Moving subjects may appear to be stationary for an instant.
- Resolution decreases in video exposed to flash light.
- Horizontal lines appear in video footage exposed to flash light.

Using FBC

FBC goes on when the brightness of the lower half of the image differs markedly from the previous half, which could be caused by light from a camera flash or other strong light source. Since FBC may be incorrectly activated in certain shooting environments, for example, in zooming that includes a bright window, be sure to use the function only for shooting footage exposed to flash light.

In some shooting environments adequate FBC effect may not be obtained even when a flash goes off.

FBC requirements

- You can use FBC in the “FBC operation enabled mode” below.
- Even if the FBC function is switched ON, it will be forced to OFF if the mode is switched to one not shown in “FBC operation enabled mode”.
When you wish to use this mode again, set the camera to a mode shown below then press the USER button and switch the FBC function ON.
- Even if the FBC function is switched ON, it will temporarily be switched OFF if shutter is switched ON or the digital zoom is operated. The FBC function returns to the ON state after shutter or digital zoom is switched OFF.
- The FBC function is switched OFF if the power switch is set to OFF.

FBC operation enabled mode

- 1080/60i², 1080/50i², 720/60P², 720/50P², 480/60i, 576/50i,
*2: VFR is limited to OFF.
- Shutter OFF
- Digital zoom OFF

Using the USER buttons

You can allocate the selected function to USER MAIN and USER buttons 1 to 4.

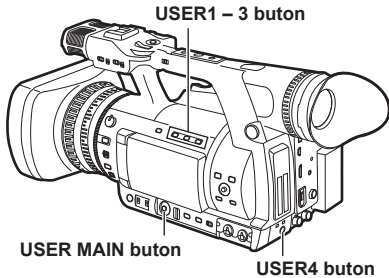

Selectable Functions

SPOTLIGHT:

Assigns auto iris control on/off for spotlight.

BACKLIGHT:

Assigns auto iris control on/off for backlight compensation. (Page 40)

ATW:

Turns the ATW function on or off. (Page 33)

ATW LOCK:

Pressing this lock during ATW operation locks the white balance. Press again to start the ATW function again.

S.GAIN:

Allocates a function that increases gain to 24 dB or greater.

The gain value can be set with SUPER GAIN on the setting menu SW MODE screen. (Page 138)

D.ZOOM:

Allocates the DIGITAL ZOOM function. Each time the button is pressed, the setting changes in the following order: x2 → x5 → x10 → OFF (x1). (Page 19)

Y GET:

Assigns a function that displays the brightness level at the center of the image.

DRS:

Assigns a function that stretches the dynamic range. The setting is linked to the ON/OFF of setting of DRS on the setting menu SCENE FILE screen. (Page 37)

TEXT MEMO:

Assigns text memory recording. (Page 42)

SLOT SEL:

Assigns P2 card slot selection.

SHOT MARK:

Assigns the shot marker function. (Page 41)

MAG A. LVL:

Assigns a function that magnifies the audio level meter. (Page 55)

LVL METER:

Allocates a function that switches between CH1/2 and CH3/4 for the audio level meter display and audio channel for headphones, built-in speaker, AUDIO OUT terminal output, and HDMI OUT output while the button is held down.

PRE REC:

Assigns a function that turns the PRE REC function on and off. (Page 44)

WFM:

Assigns a function that switches WAVE FORM display.

The WAVE FORM display is selected using the menu option WFM in the SW MODE screen.

This is the same function as the WFM button. (Page 40)

LAST CLIP:

Allocates a function to delete the clip shot immediately beforehand. (Page 42)

FBC:

Turns the FBC function on or off. (Page 38)

LCD B.L.:

Allocates a function to switch the backlight brightness of the LCD monitor. The setting is linked to the LCD BACKLIGHT on the setting menu DISPLAY SETUP screen. (Page 148)

• As factory settings, the following functions are allocated to the buttons displayed.

USER MAIN	: Y GET
USER1	: BACKLIGHT
USER2	: TEXT MEMO
USER3	: DRS
USER4	: SLOT SEL

• If you press a USER button to which one of the functions has been allocated, and then turn OFF the power during operation of the USER button function, the effect added to the image will not be retained.

SPOTLIGHT, BACKLIGHT, ATW, ATW LOCK, S.GAIN, D.ZOOM, Y GET, WFM, MAG A.LVL, FBC

Shooting techniques for different targets (continued)

Backlight compensation

Press the USER button you have allocated to the BACKLIGHT feature when shooting subjects lit from the back.

BACK appears on the screen.

Backlight compensation adjusts the iris so the subject doesn't come out dark.

Press the same USER button to turn the feature off.

- "Using the USER buttons" (Page 39)

Color bars

Press the BARS button in CAMERA mode to output a color bar screen to a television or monitor so you can adjust them.

Press the button again to turn the feature off.

BARS button

The color bar screen turns off and camera-recorder image appears.

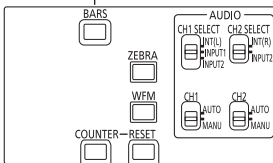

A 1 kHz test tone is output in the color bar screen when LEVEL1 or LEVEL2 is selected under TEST TONE on the setting menu AUDIO SETUP screen. (Page 143)

- The color bar can be recorded together with a 1 kHz test tone.

Waveform monitor function

Press the WFM button in CAMERA mode to display a waveform of the image on the LCD monitor.

Pressing the WFM button once again closes the waveform display.

- WFM (Page 139) on the setting menu SW MODE screen allows you to switch between the waveform and vector display.
- The viewfinder does not show the waveform display.
- The waveform does not appear when the focus assist function is used.
- The waveform display cannot be recorded.
- You can allocate the same function as the WFM button to USER buttons. (Page 39)

Adjusting the volume while shooting

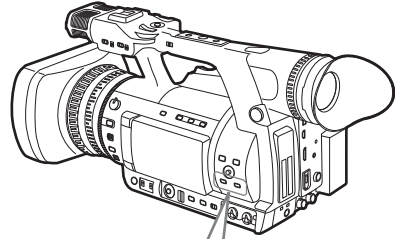

Adjusting the volume



If you are monitoring the sound through headphones while shooting, you can adjust the volume with the PAGE/AUDIO MON/VAR button.

- Adjustment of input audio level is performed with the AUDIO LEVEL knob. (Page 54)

Backup recording

If you have connected equipment to the 1394 terminal (Page 103), you can make automatic backup recordings of whatever you are shooting.

- "Control of external devices through 1394 connection" (Page 106)

2-slot continuous recording

If you insert two P2 cards into the two card slots, this function allows you to record continuously on the two cards.

You can also record continuously on three or more cards by replacing one card while data is being recorded on the other. (Hot swap recording) However, depending on when the P2 card is inserted into an empty slot (immediately after prerecording, or before or after continuous recording spanning two slots), there may be a delay in recognizing the P2 card.

We recommend inserting the P2 card while there is at least one minute remaining on the card that is recording.

You can change the slot for recording with one touch if you press a USER button to which the SLOT SEL has been allocated.

- “Using the USER buttons” (Page 39)
- You cannot change slots while recording so do this during recording standby.
- Does not support hot swap playback.

Shot mark function

The marks attached to the thumbnails of clips are called shot marks. On the thumbnail screen monitor you can select only those clips with a shot mark and display them or play them back.

- “Switching the thumbnail display” (Page 80)
- During recording, when you press the USER button to which the SHOT MARK function has been allocated, MARK ON appears in the LCD monitor or the viewfinder, and a shot mark is set for the thumbnail of the clip being recorded. If you press the button again, the shot mark is released.
- “Using the USER buttons” (Page 39)

-
- **A shot mark added during a pause after recording is added to the most recently recorded clip.**
 - **Shot marks can be added also in the thumbnail display.**
 - **The shot mark function is not available during loop recording, interval recording and one-shot recording. When this function is not available, pressing this button displays SHOT MARK INVALID.**
 - **Shot marks can be set or cancelled in playback pause mode but not during playback.**
 - **Shot marks cannot be set or deleted for video data created in a single hot-swap recording session consisting of multiple clips unless all the P2 cards that contain the video data for the entire session are inserted. In clips that consist of multiple clips like the one above, shot marks can be added only to the first clip of video data.**
-

Shooting techniques for different targets (continued)

Text memo recording

This function adds text memos at the video points on the clip now being recorded or played back.

When you press the USER button to which the TEXT MEMO function has been allocated, the text memo will be recorded at that point.

- “Using the USER buttons” (Page 39)

On the thumbnail screen you can select only those clips where text memos have been added, and then either display those clips or play them back.

- “Switching the thumbnail display” (Page 80)

You can record up to a hundred text memos per clip.

- You cannot record text memos during loop recording, interval recording or one-shot recording.
- “TEXT MEMO INVALID” appears when you cannot record text memos.

Time stamp function

Use the time stamp function to record date and time of shooting on the video.

Select ON under TIME STAMP on the setting menu RECORDING SETUP screen.

“**R**” prefixes the date and time display in the viewfinder and the LCD monitor when the time stamp function is on.

- “**R**” is not recorded on the video.
- The size and location of the date and time characters will vary with the recording format.
- The data recorded depends on the DATE/TIME setting on the setting menu DISPLAY SETUP screen. No data is recorded when OFF is selected.
- This timestamp is superimposed on the video output from the DVCPRO/DV terminal.

LAST CLIP DELETE function

Assign LAST CLIP to any of the USER MAIN or USER 1 – 4 buttons to enable a convenient way to delete the last recorded clip.

Pressing the USER button to which LAST CLIP was assigned displays a YES/NO confirmation dialog on the screen.

Select YES, and the last recorded clip is deleted and “LAST CLIP DELETE OK” is displayed.

- “Using the USER buttons” (Page 39)
- Select NO to cancel clip deletion.
- Clips cannot be deleted even when you press the button if you have switched to PB/THUMBNAIL mode or PC mode after shooting, when recording 1394 input, or during menu display. Then it will not be possible to delete the clip by turning the power off and turning it back on.
- In hot swap recording, the clip delete function is not available unless all the P2 cards containing data shot in one recording operation are inserted.
- The clip delete function is not available when the one-clip recording is set.

Using special recording modes

During P2 card recording, the following special recording modes can be enabled from the RECORDING SETUP screen: pre-recording, interval recording, one-shot recording, loop recording, and one-clip recording.

These recording modes (excluding one-clip recording) are available only with the following settings. One-clip recording mode is available in all recording modes, except when VFR is turned ON.

SYSTEM MODE	REC FORMAT	Other conditions
1080-59.94i	DVCPROHD/60i AVC-I 100/60i AVC-I 50/60i	<ul style="list-style-type: none">• Set CAMERA MODE to 60i or 30P.• Turn VFR OFF.
1080-50i	DVCPROHD/50i AVC-I 100/50i AVC-I 50/50i	<ul style="list-style-type: none">• Turn VFR OFF.
720-59.94P	DVCPROHD/60P AVC-I 100/60P AVC-I 50/60P	<ul style="list-style-type: none">• Turn VFR OFF.
720-50P	DVCPROHD/50P AVC-I 100/50P AVC-I 50/50P	<ul style="list-style-type: none">• Turn VFR OFF.
480-59.94i	DVCPRO50/60i DVCPRO/60i DV/60i	<ul style="list-style-type: none">• Set CAMERA MODE to 60i or 30P.
576-50i	DVCPRO50/50i DVCPRO/50i DV/50i	—

Using special recording modes (continued)

Pre-recording (PRE REC)

This function is used to start recording a certain number of seconds (approx. 3 seconds for HD recordings or approx. 7 seconds for SD recordings) before actual recording starts.

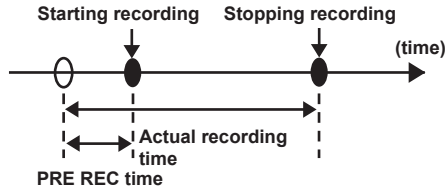

1 Check that the SYSTEM SETUP screen is set up as described on page 43.

- Refer to the section “Using the setup menus” (Page 28 of Vol. 1) for menu operation.

2 Select ON in the menu option PREREC MODE in the RECORDING SETUP screen. (Page 141)

- The following indications appear in the special recording display area in the viewfinder or LCD monitor.
 - During recording: “P-REC” stays lit.
 - During a pause: “P-PAUSE” stays lit.
- “Screen displays” (Page 121)

3 Press the START/STOP button.

- This setting will record audio and video a time period prior to start of recording.
- The following recording modes will disable the pre-recording function and start respective recording function when selected.
 - Recording of video input via the IEEE1394 connector
 - When changing recording formats
 - After a change from playback to recording
 - During interval recording
 - During one-shot recording
 - During loop recording
 - There may be a short delay in start of audio and video recording when the START/STOP button is pressed directly after switching from thumbnail display or playback to view what you are shooting, after turning the power on and after changing the PREREC MODE.

Interval recording (INTERVAL REC)

This function is used to record 1 frame at the time interval set in the INTERVAL TIME item.

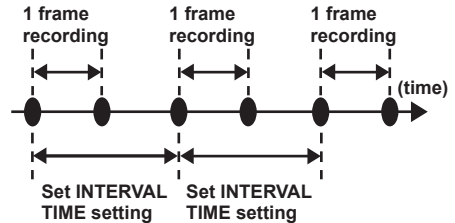

1 Check that the SYSTEM SETUP screen is set up as described on page 43.

- Refer to the section “Using the setup menus” (Page 28 of Vol. 1) for menu operation.

2 Select INTERVAL in the menu option PREREC MODE in the RECORDING SETUP screen. (Page 141)

3 Set the time in the menu option INTERVAL TIME in the RECORDING SETUP screen. (Page 141)

4 Press the START/STOP button.

- The camera-recorder will repeat 1-frame recording for the time interval set in the INTERVAL TIME option.
- Push the Operation lever in the ▼ direction (STOP) to stop recording.
- To cancel this function, turn the camera-recorder off or select NORMAL in the REC FUNCTION option.
- The following indications appear to the left of the operation status display.
 - During recording: “I-REC” stays lit.
 - During a pause: “I-PAUSE” stays lit.
- When a setting of less than 2 seconds is made in step 3, “I-REC” blinks according to time setting during recording.
- When stopped: “I-” in “I-PAUSE” blinks.

- The pre-recording and one-clip recording functions are not available.
- Sound is not recorded.
- Data recorded (until the stop recording) in this mode is recorded as a single file.
- There is no output from the DVCPRO/DV connector.

One-shot recording (ONE SHOT REC)

This function records a single shot at each unit of time which has been set.

- 1 **Check that the SYSTEM SETUP screen is set up as described on page 43.**
 - Refer to the section "Using the setup menus" (Page 28 of Vol. 1) for menu operation.
- 2 **Select ONE SHOT in the menu option REC FUNCTION in the RECORDING SETUP screen. (Page 141)**
- 3 **Set the time in the menu option ONE SHOT TIME in the RECORDING SETUP screen. (Page 141)**
- 4 **Press the START/STOP button.**
 - The camera-recorder will pause recording after making a recording that lasts the duration set in step 3.
 - Push the Operation lever in the ▼ direction (STOP) to stop recording.
 - To cancel this function, turn the camera-recorder off or select NORMAL in the REC FUNCTION option.
 - The following indications appear to the left of the operation status display.
 - During recording: "I-REC" stays lit.
 - During a pause: "I-PAUSE" stays lit.
 - When stopped: "I"- in "I-PAUSE" blinks.

- **No other functions are available during operation.**
- **The pre-recording and one-clip recording functions are not available.**
- **Sound is not recorded.**
- **Data recorded (until the stop recording) in this mode is recorded as a single file.**
- **There is no output from the DVCPRO/DV connector.**
- **During continuous one-shot recording, recording operation speed may be decreased.**

Using special recording modes (continued)

Loop recording (LOOP REC)

- When two P2 cards are inserted in the P2 card slots, each card is recorded in succession.
- When there is no longer any space left on the second cards, recording starts over from the first card by recording new clips over saved old clips.
 - “Splitting clips recorded on P2 cards” (Page 14)

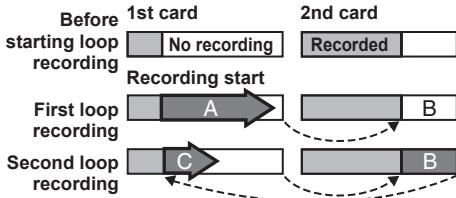

Recording will be made on the areas with no recording consecutively (A, B, then C). When all areas on all cards are recorded, new recording (C) will be made by overwriting the area A.

- 1 Check that the SYSTEM SETUP screen is set up as described on page 43.**
 - Refer to the section “Using the setup menus” (Page 28 of Vol. 1) for menu operation.
- 2 Select LOOP in the menu option REC FUNCTION in the RECORDING SETUP screen. (Page 141)**
- 3 Press the START/STOP button.**
 - Recording starts.
 - Press the START/STOP button to stop recording.
 - To cancel this function, turn the camera-recorder off or select NORMAL in the REC FUNCTION item.
 - The following indications appear to the left of the operation status display.
 - During recording: “L-REC” stays lit.
 - During a pause: “L-PAUSE” stays lit.
 - When remaining memory is low: “P2 LACK L-” blinks.

- Use two P2 cards with at least one minute of remaining recording time.
- The mode check screen shows standard recording time depending on recording format as remaining P2 card time. When loop recording is stopped right after deleting old data, the time of recordings on the card may be shorter than indicated.
- This function is not available during IEEE1394 input.
- The pre-recording and one-clip recording functions are not available.
- Canceling this function may take some time. The succeeding operations are not available until the P2 CARD ACCESS LED goes from blinking to steady lighting.
- During loop recording, the access LEDs for all P2 cards used in the recording light orange or blinks. Note that removing any of the P2 cards will terminate loop recording.
- Irregularity in the input GENLOCK reference signal during loop recording may terminate recording.

One-clip recording (ONE CLIP REC)

Instead of creating a new clip for each recording session (i.e., operation from REC start to stop), this mode compiles images from multiple recording sessions into a single clip.

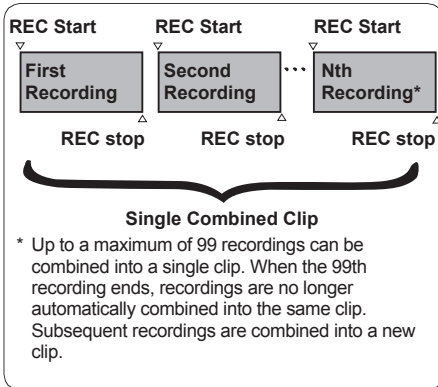

To use this function, set the menu option ONE CLIP REC to ON in the RECORDING SETUP screen. (Page 142)

When one-clip recording mode is enabled, "1-CLIP" appears in the viewfinder and at the top of the LCD monitor.

When you press the START/STOP button on the camera-recorder to start your first recording, "START 1*CLIP" appears.

Any subsequent recordings are automatically combined into the clip. Up to a maximum of 99 clips can be combined into a single clip.

To record a new clip

Follow the instructions below to use a new and separate clip and end combining to the clip.

- Push and hold the Operation lever in the ▼ direction (STOP) for about 2 seconds while recording is paused. (operating while recording is on standby)

Or

- Press and hold the START/STOP button for about 2 seconds to stop recording. (operating while recording is in progress)

Follow the instructions above to end combining to the clip. "END 1-CLIP" displays. Subsequent recordings use a new and separate clip.

- In addition to the aforementioned steps, the following ends combining to the clip and subsequent recordings use a new clip.

- When the power is turned off
- When the P2 card with the previous recording is removed
- When the P2 card is formatted or the clip is deleted (when the previous combined clip does not exist)

- The clip does not stop combining even when the STOP button is pressed in the Menu or on the thumbnail display.

To exit one-clip recording mode

Set the menu option ONE CLIP REC to OFF.

To cue to the start of the combined section of the clip

A text memo can be automatically added to the start of the recording, the start of a section can be cued for playback, and the thumbnail of the location can be checked before each recording. To automatically add a text memo to the start point of the recording, set the menu option START TEXT MEMO to ON in the RECORDING SETUP screen. (Page 142)

Check and playback the location of the added text memo by selecting THUMBNAIL → TEXT MEMO CLIPS from the Thumbnail Menu and moving the cursor over the desired clip.

Refer to "Playing back a clip at the position where a text memo is recorded" (Page 83) for details.

To cue to the location of the text memo during playback, set the menu option SEEK SELECT to CLIP&T in the OTHER FUNCTIONS screen, and push the Operation lever in the ◀▶ direction while playback is paused.

Using special recording modes (continued)

Precautions for one-clip recording mode

- This mode will not function when the interval recording, one-shot recording, loop recording, or VFR recording functions are selected.
- This mode will not function when the menu option REC SIGNAL is set to 1394.
- The menu and thumbnail operations are restricted as follows when combining to the clip. Push and hold the Operation lever in the ▼ direction (STOP) for about 2 seconds to stop combining to the clip when switching to this mode.
 - The following menu items cannot be changed.
SYSTEM MODE, REC SIGNAL,
ASPECT CONV, CAMERA MODE,
REC FORMAT, REC FUNCTION,
25M REC CH SEL

You can set VFR to ON even while continuing to link clips by using the SCENE FILE dial, SHTR/F.RATE dial, or the menu. When you do so, the compiling process is stopped, and a new clip will be created with each recording operation thereafter.

- The following Menu items, related to the reading/ writing of the SD memory card and reading of the settings file, cannot be executed.
LOAD/SAVE/INIT in SCENE FILE, all options in CARD FUNCTIONS, USER FILE and MENU INIT in OTHER FUNCTIONS
- The following thumbnail menu items cannot be selected and executed.
OPERATION→COPY
- The processing time to complete the recording may take a little more time than normally to allow the clip to be combined with subsequent recordings.
- The fade process does not work on discontinuous audio during playback where the recordings are combined within the clip.
- If non-linear editing software is used on clips with multiple combined recordings, the software may not operate normally (as of Sep. 2011).
For the latest information on software that has been confirmed to work with these types of clips, visit the support desk at the following website.

<http://pro-av.panasonic.net/>

Adjusting the shutter speed

Shutter speed is set using the SHTR/F.RATE dial and DIAL SEL button.

As well as the shutter speed, you can use the SHTR/F.RATE dial to select settings for synchro scan and frame rate.

Using SHTR/F.RATE dial

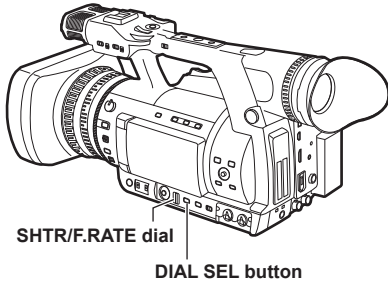

Press the SHUTTER button.

- The function of the SHTR/F.RATE dial changes in the following order.
SHUTTER → SYNCHRO SCAN →
FRAME RATE → LOCK → SHUTTER →
- SYNCHRO SCAN can be selected when the SHUTTER is set to SYNCHRO SCAN.
SYNCHRO SCAN is displayed only when the SHUTTER is set to SYNCHRO SCAN.
- FRAME RATE can be selected when the mode is 1080i or 720P.

To prevent accidental operation, DIAL LOCK is automatically applied when no operation is performed for approximately 12 seconds.

Setting SHUTTER mode

- 1 Push DIAL SEL to select SHUTTER mode.**
- 2 Push the SHTR/F.RATE dial.**
 - The SHUTTER mode changes ON/OFF.
 - The shutter speed changes by turning the SHTR/F.RATE dial in the shutter mode ON.
(Page 50)

-
- Remember that the faster the shutter speed, the lower the sensitivity.
 - It will take longer to focus when the shutter speed has been reduced so it is recommended that the unit be secured to a tripod, etc. for use.
 - The screen may be distorted when changing the SYNCHRO SCAN or SHUTTER setting.
 - Under fluorescent lighting and other discharge lighting systems, horizontal stripes may appear on the screen. Changing the shutter speed may correct this problem.
 - A subject that is captured when moving quickly across the field of view may appear distorted. This is due to the signal read out format of the image sensor (MOS sensor) and is not a malfunction.
 - The red, blue and green dots that may appear on the screen at low shutter speeds (1/6 to 1/15) do not indicate a malfunction.
-

Adjusting the shutter speed (continued)

If all modes and speeds are available, the display changes in the following order:

■ When SYSTEM MODE is set to 1080-59.94i, 720-59.94P, 480-59.94i

For 60i and 60P recording

S/S → (1/15) → (1/30) → 1/60 → 1/100 → 1/120
→ 1/250 → 1/500 → 1/1000 → 1/2000

For 30P recording

S/S → (1/7.5) → (1/15) → 1/60 → 1/100 → 1/120
→ 1/250 → 1/500 → 1/1000 → 1/2000

For 24P recording

S/S → (1/6) → (1/12) → 1/60 → 1/100 → 1/120
→ 1/250 → 1/500 → 1/1000 → 1/2000

- The bracketed () speeds cannot be selected when VFR is on.

■ When SYSTEM MODE is set to 1080-50i, 720-50P, 576-50i

For 50i and 50P recording

S/S → (1/12.5) → (1/25) → 1/50 → 1/60 → 1/120
→ 1/250 → 1/500 → 1/1000 → 1/2000

For 25P recording

S/S → (1/6.25) → (1/12.5) → 1/50 → 1/60 → 1/120
→ 1/250 → 1/500 → 1/1000 → 1/2000

- The bracketed () speeds cannot be selected when VFR is on.

Setting SYNCHRO SCAN mode

1 Select SYNCHRO SCAN in the SHUTTER mode.

- Turn the SHTR/F.RATE dial, the value displayed after 1/2000 is the current SYNCHRO SCAN setting value. Select this value.

2 Press DIAL SEL button to select SYNCHRO SCAN function.

3 Turn the SHTR/F.RATE dial.

- It is possible to set the SYNCHRO SCAN shutter speed.
- The shutter speed is set higher by pushing and turning SHTR/F.RATE dial.

Range of variation in each mode

■ When SYSTEM MODE is set to 1080-59.94i, 720-59.94P, 480-59.94i

- 60P/60i mode: 1/60.0 to 1/249.8
- 30P/30PN mode: 1/30.0 to 1/249.8
- 24P/24PA/24PN mode: 1/24.0 to 1/249.8

■ When SYSTEM MODE is set to 1080-50i, 720-50P, 576-50i

- 50P/50i mode: 1/50.0 to 1/250.0
- 25P/25PN mode: 1/25.0 to 1/250.0

■ Setting the menu option SYNC SCAN TYPE in the SCENE FILE screen to deg provides a guide to setting and displaying shutter angle. (Page 132)

- 3.0 d to 359.5 d
- If SYSTEM MODE setting is changed, shutter speed may also be changed.

Setting FRAME RATE mode

1 Press DIAL SEL button to select FRAME RATE function.

When VFR is ON, the frame rate indicator on the viewfinder and LCD monitor flash as shown in the diagram below, indicating that you can alter the frame rate.

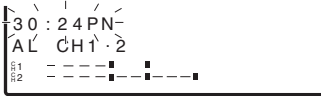

- If they are not flashing, VFR mode is OFF. Press the SHTR/F.RATE dial to set VFR mode to ON. VFR mode switches between ON/OFF each time the SHTR/F.RATE dial is pressed.

2 The FRAME RATE is set by turning the SHUTR/F.RATE dial.

- If no operation is performed for approximately 10 seconds, the frame rate indicator illuminates and the dial returns to a locked state.
- The FRAME RATE mode can be set using FRAME RATE on the setting menu SCENE FILE screen.

Use 1080i or 720P for the frame rate function. However, when 1080i is selected with DVCPRO HD recording, you cannot record unless CAMERA MODE is set to 60i (50i).

Switching audio input

During shooting, you can record up to four channels of sound. You can also switch the input sound to be recorded on each of the channels to the built-in microphones, external microphones or audio equipment connected to camera-recorder. (See table below.)

CH1 SELECT switch	CH1 recording	CH3 recording
INT (L)	Built-in microphone Lch	INPUT1 switch selection is valid (LINE/MIC select)
INPUT1	INPUT1 switch selection is valid (LINE/MIC select)	Built-in microphone Lch
INPUT2	INPUT2 switch selection is valid (LINE/MIC select)	Built-in microphone Lch

CH2 SELECT switch	CH2 recording	CH4 recording
INT (R)	Built-in microphone Rch	INPUT2 switch selection is valid (LINE/MIC select)
INPUT2	INPUT2 switch selection is valid (LINE/MIC select)	Built-in microphone Rch

However, the following restrictions apply depending on the format used.

- Refer to the section "Recording format list" (Page 164) recording format.

When the AVC-I100, AVC-I50, DVCPROHD or DVCPRO50 format is used:

The recording mode is fixed at 4-channel recording.

When the DVCPRO or DV format is used:

Either 2 or 4 channels can be selected using 25M REC CH SEL on the setting menu AUDIO SETUP screen.

INPUT1 LINE/MIC switch

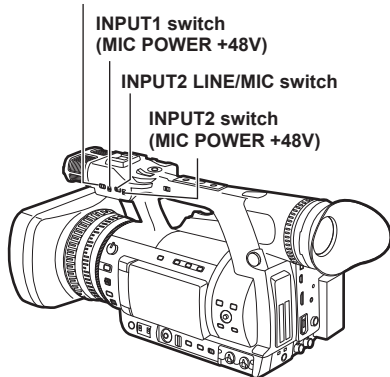

AUDIO CH2 SELECT switch

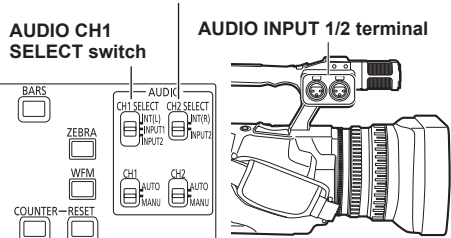

Using the built-in microphone

- 1 Switch the **AUDIO CH1 SELECT** switch to **INT (L)**.
 - Audio from the built-in microphone Lch is recorded to audio channel 1.
- 2 Switch the **AUDIO CH2 SELECT** switch to **INT (R)**.
 - Audio from the built-in microphone Rch is recorded to audio channel 2.

Using another microphone and audio equipment

1 Connect an external microphone or audio equipment to the **AUDIO INPUT 1/2 (XLR, 3 pin) terminal.** (Page 101)

2 Use the **INPUT 1/2 switch to switch the audio input.**

LINE:

(audio equipment is connected)

Input level is 0 dBu.

MIC:

(another microphone is connected)

Input level is – 50 dBu.

You can change the input level to – 40 dBu or – 60 dBu in the setup menus, **RECORDING SETUP** screen **MIC GAIN1** and **MIC GAIN2.** (Page 144)

Be aware that sensitivity will be higher if you choose – 60 dBu so you will record more noise.

- When using an AG-MC200G (optional), set **MIC GAIN** to – 50 dBu.

When using the phantom microphone

Set the **INPUT 1/2 switch (MIC POWER +48 V)** to **ON.**

ON:

(When using the phantom microphone)
+48V power supply to **INPUT 1/2 terminal.**

OFF:

(When a phantom microphone is not connected)

- No power supply for **INPUT 1/2 terminal.**
- The battery will discharge faster if you use a phantom microphone.
- Set to **OFF** if you connect equipment not compatible with +48V. You can damage such equipment if you leave the setting at **ON.**

3 Select the input signal to be recorded on the tracks of audio channels 1 to 4.

- Select the input to be recorded on **CH1** and **CH3** with the **AUDIO CH1 SELECT** switch, and select the input to be recorded on **CH2** and **CH4** with the **AUDIO CH2 SELECT** switch. (Page 52)
- When inputting the microphone signal to channels 1 and 2, connect the microphone to **AUDIO INPUT 2** and switch both **AUDIO CH1 SELECT** and **AUDIO CH2 SELECT** to **INPUT 2.**

Adjusting the audio recording level automatically

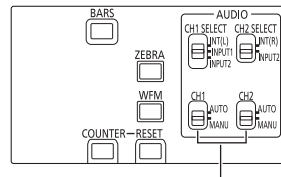

AUDIO AUTO/MANU CH1, CH2 switch

Set the **AUDIO AUTO/MANU CH1** or **CH2** switch to **AUTO** position.

Adjust the audio signal recording level input through the built-in microphone and the **AUDIO INPUT1/2** terminals (XLR, 3 pin) automatically.

- **CH1/CH2** can be set separately.
- When **AUTO** is set, the recording level adjustment using the **AUDIO LEVEL** knob and the setting in the **LIMITER CH1/LIMITER CH2** item of the setup menu **AUDIO SETUP** screen (Page 143) are disabled.

Since the audio signal recording level is adjusted automatically, the zoom operation sound may be recorded if zooming quickly, depending on the environment. In that case, adjust the audio recording level in manual mode.

Switching audio input (continued)

Adjusting the recording level

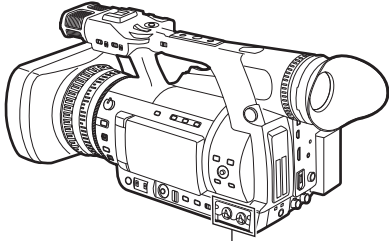

AUDIO LEVEL knob (CH1, CH2)

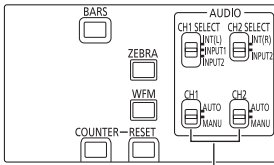

AUDIO AUTO/MANU CH1, CH2 switch

Use the AUDIO LEVEL knob to adjust the recording level of the built-in microphone or of audio signals input through the AUDIO INPUT 1/2 (XLR, 3 pin) terminal.

- To adjust the volume of the sound for monitoring, see “Adjusting the volume while shooting” (Page 40).

To adjust the recording levels for Audio Channels 1 and 2, follow the steps below.

- 1** Set **AUDIO OUT** on the setting menu **AUDIO SETUP** screen to **CH1/CH2** and confirm that the display is **1, 2**, so that the audio level meter display indicates **CH1, CH2**.
- 2** Position the **AUDIO AUTO/MANU CH1, CH2** switch at **MANU**.

- 3** While checking the audio channel level meter in the display window or the audio level meter in the viewfinder, adjust the **AUDIO LEVEL (CH1, CH2)** control.

- Note that if the level exceeds the top bar (0 dB), the word **OVER** illuminates to show that the input level is excessive. Adjust so that maximum sound levels do not reach the 0 dB bar.



OVER indication

Pressing the **USER** button to which the magnification of the audio level meters (**MAG A.LVL**) has been assigned magnifies the audio level meters.

- “Audio level meter magnification” (Page 55)

- The **CH1** and **CH2** characters are highlighted (they will appear in white text) when **INT MIC** on the **AUDIO SETUP** screen is set to **ON**.



INT MIC ON



INT MIC OFF

Check the recording level prior to shooting.

- The recording level is set higher than for Panasonic's broadcast-use camera-recorder recorders (AJ series, AG-HPX500, 370 or 300 series).

CH3 and CH4 recording levels

Conditions and input levels set in the menu options AUTO LEVEL CH3 and the AUTO LEVEL CH4 in the AUDIO SETUP screen change the operation of the audio level of channels 3 and 4 as shown below. These functions cannot be manually adjusted.

Each option can be selected in the AUDIO SETUP screen.

AUTO LEVEL CH3 (CH4)	LIMITER CH3 (CH4)	
	ON	OFF
ON	LIMITER OFF AGC* ON	LIMITER OFF AGC ON
OFF	LIMITER ON AGC OFF	LIMITER OFF AGC OFF

* AGC: Auto Gain Control

Audio level meter magnification

Press USER button to which MAG A. LVL has been assigned to display a magnification of the audio level meter (available also when LEVEL METER in the DISPLAY SETUP menu is set to OFF).

Press the button again to return to normal audio level meter size.

Turning on MODE CHECK during audio level meter magnification clears the audio level meter display. After MODE CHECK use, the audio level meter reappears at normal size.

• "Using the USER buttons" (Page 39)

(Only for AG-HPX250P)

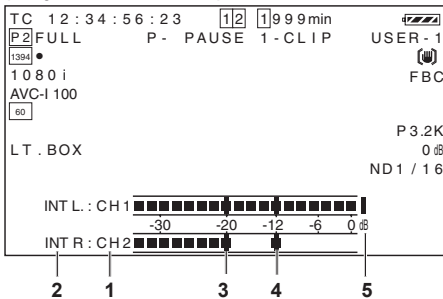

(Only for AG-HPX250EN)

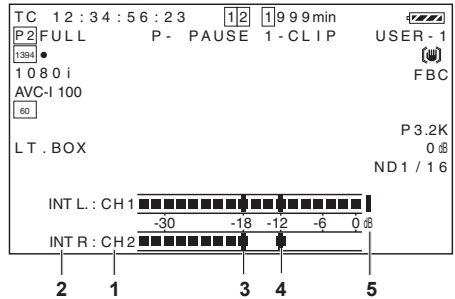

1 Channel display

This displays the currently monitored audio channel.

2 Input system display

Displays the input system for the audio channel currently in use.

- OFF (Built-in microphone selected and switched off)
- INT L, R (Built-in microphone selected)
- XLR1, XLR2 (INPUT 1, 2 selected)

3 Standard level bar

(Only for AG-HPX250P)

Displayed at -20 dB and -12 dB.

(Only for AG-HPX250EN)

Displayed at -18 dB and -12 dB.

4 Peak hold display

Holds the audio peak level indication for 1 second.

5 Excessive level indicator

Displayed in red when the audio level exceeds 0 dB.

Using scene files (Scene File Data)

Each position of the SCENE FILE dial stores settings for specific shooting situations. When shooting, you can retrieve the necessary file instantly using scene file dial.

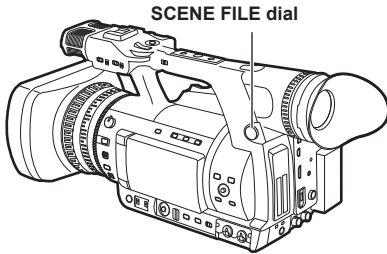

- Note that changing scene files during recording will not change VFR and frame rate settings. To make such changes, set it on recording standby status.

■ Factory setting

F1 (SCENE)

File suitable for normal shooting.

F2 (SCENE FLUO.)

File suitable for shooting under fluorescent lights, ie. indoors.

F3 (SCENE SPARK)

File suitable for SD shooting with a greater range of resolution, coloring and contrast.

F4 (SCENE B-STR)

File for increasing the contrast of dark areas, such as when shooting sunsets.

F5 (SCENE CINE V)

File suitable for shooting movie-like scenes where the contrast is to be emphasized.

F6 (SCENE CINE D)

File suitable for shooting movie-like scenes where the dynamic range is to be emphasized.

Changes to scene files do not affect SYSTEM MODE settings. Use the SYSTEM SETUP screen to make such changes.

Changing scene file settings

■ Example 1: Change the name of the scene file.

- 1 Turn the scene file dial, then select the scene file to be changed.
- 2 Select the menu option NAME EDIT in the SCENE FILE screen, then press the Operation lever in the ▲ ▼ direction.
 - For details on menu operation, refer to “Using the setup menus” (Page 28 of Vol. 1).

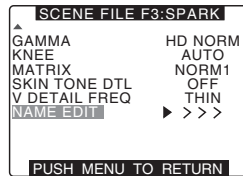

- 3 Press SET on the Operation lever (or push it in the ► direction), then push it in the ▼ direction, select CHANGE, and press SET once again.

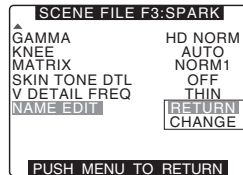

- 4 Set the filename with 6 characters by using Operation lever when the screen below is displayed.

- ▲ ▼: Character shift
- ◀ ▶: Character selection
- SET: Character fix
- Characters that can be set
 - space (□) → alphabet (A to Z)
 - numerics (0 to 9)
 - symbols (; ; < = > ? @ [\] ^ _ - /).
- If the RESET button is pressed when the filename has been set, the characters are cleared.



- Pressing the MENU button fixes the current settings and closes NAME EDIT.
- Values that have been fixed are maintained even if the power is switched OFF or the dial is changed. The settings for all items in scene files are also maintained in the same way.

■ Example 2: Save the F1 scene file to the camera-recorder.

1 Select the menu option LOAD/SAVE/INIT in the SCENE FILE screen, then press the SET button on the Operation lever.

- Confirm SCENE FILE F3 display or not.
- For details on menu operation, refer to "Using the setup menus" (Page 28 of Vol. 1).

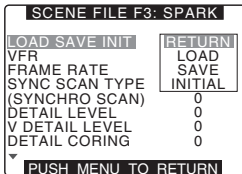

2 Select SAVE and press the SET button on the Operation lever.

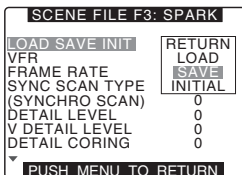

3 Select YES when the screen below is displayed, and press SET on the Operation lever.

- To return to the menu level above, press the MENU button.

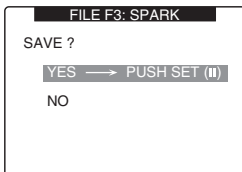

- "PROCESSING" appears and the following message is shown when all settings have been completed.



- After changing the scene file settings, to return to the settings to the previously saved values, select LOAD in step 2 and perform the operation described in step 3.
- To return the scene file settings to their factory defaults, select INITIAL in step 2 and perform the operation described in step 3.
- To save and read user file settings or return them to their factory defaults, open the setting menu OTHER FUNCTIONS screen and run USER FILE in the same way as when handling scene files.

Using scene files (Scene File Data) (continued)

Saving scene files and other settings on SD memory cards

You can save up to four scene file settings or other settings as files on an SD memory card, and you can also load them from the card.

- Current scene file settings are automatically saved in the camera-recorder and written to an SD memory card. When data has been read from an SD memory card, the current settings are rewritten at the same time as the data saved inside the unit.
- The data in all the scene files, F1 to F6, is rewritten.
- Be sure to read <Cautions in using SD memory cards> (Page 162) regarding SD memory handling.

The following procedure shows how to save scene files.

1 Set the POWER/MODE switch to ON.

2 Select SCENE FILE from the setting menu CARD FUNCTIONS screen, and press SET on the Operation lever (or push it in the ► direction).

- For details on menu operation, refer to “Using the setup menus” (Page 28 of Vol. 1).

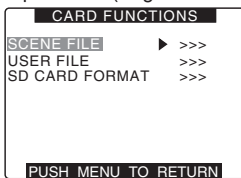

3 Select CHANGE, and press SET on the Operation lever, (or push it in the ► direction).

- Select the menu option USER FILE for other settings.

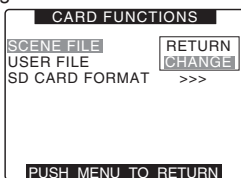

4 Push the Operation lever in the ▲ ▼ direction, and select file number (1 to 4).

- Press the SET button again to confirm the setting.

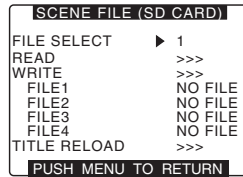

5 Select WRITE → EXECUTE with the Operation lever, and press SET.

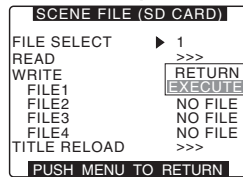

6 Push the Operation lever in the ◀ direction and select YES when the screen below is displayed, and press SET.

- In the following example, TITLE 1 is the filename.
- When writing is completed, WRITE OK appears.

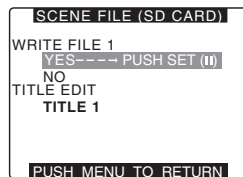

To load a file

Perform steps 1 to 4. Select READ in step 5, select EXECUTE and press the SET button on the Operation lever. READ OK appears when loading completes.

Like scene files, process user files by using the menu option USER FILE in the CARD FUNCTION screen.

Reloading Files From an SD Memory Card

Perform steps 1 to 3, move to TITLE RELOAD so that YES is displayed in step 5, and press the SET button on the Operation lever. The file is reloaded.

To title a file

- 1 Perform steps 1 to 5.
- 2 Set the filename with 8 characters by using Operation lever.
 - ▲ ▼: Character shift
 - ◀ ▶: Character selection
 - SET: Character fix
 - Characters that can be set
 - space (□) → alphabet (A to Z)
 - numerics (0 to 9)
 - symbols (; : < = > ? @ [\] ^ _ - /).
 - If the RESET button is pressed when the filename has been set, the characters are cleared.

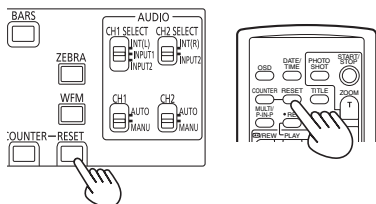

- 3 After input is complete, at the left end of the characters push the Operation lever in the ◀ direction (or in the ▶ direction from the right end of the characters) to select YES and press SET.

- If WRITE NG FORMAT ERROR appears, format the SD memory card. (Page 16)
- If WRITE NG WRITE PROTECT appears, change the lock tab position to enable writing.
- If WRITE NG CANNOT ACCESS appears, quit all other operations (such as playback) before proceeding.
- If WRITE NG ERROR appears, the SD memory card may be defective. Replace it.

Using scene files (Scene File Data) (continued)

Configuration of setup data files

This camera makes it possible to save a scene file to each of the F1 to F6 positions on the SCENE FILE dial.

Use of an SD memory card makes it possible to save up to four of the F1 to F6 files on an SD card for later retrieval.

The setting menu values can be stored as a user file in the camera-recorder and up to four files can be stored on the SD memory card.

The setting data files are configured as shown below.

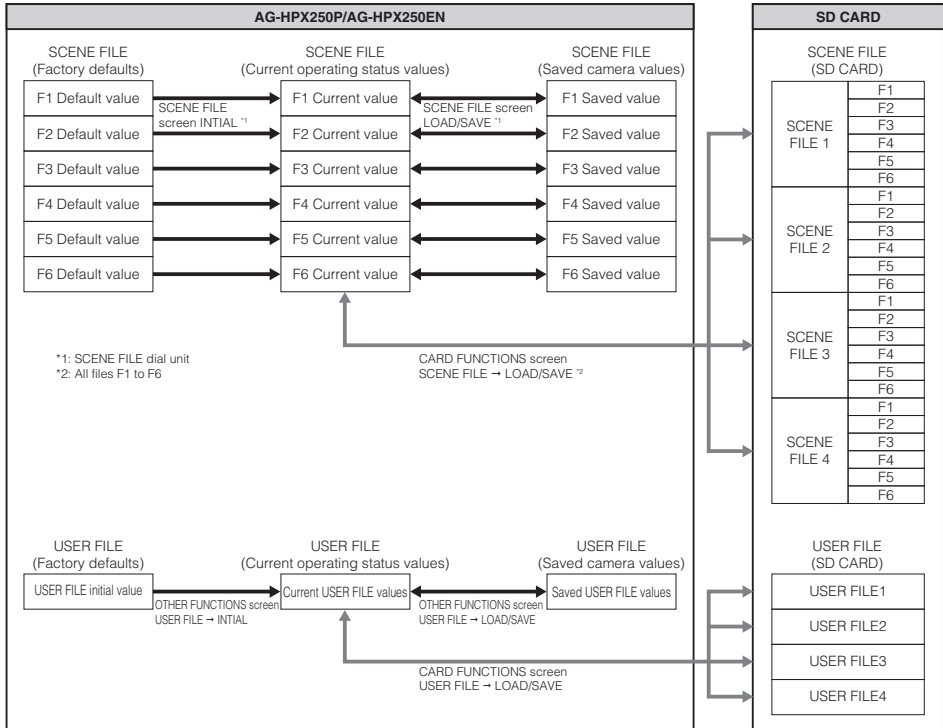

- Running the menu option MENU INIT in the OTHER FUNCTIONS screen returns all current operating status values and saved camera-recorder values in the F1 to F6 scene files as well as in the user file to their factory defaults. This function does not return the TIMEZONE setting to its factory default.
- SCENE FILE and USER FILE settings cannot be operated when recordings can be compiled to a previous clip in one-clip recording mode (i.e., when "1*CLIP" is displayed). After closing the menu, push the Operation lever in the ▼ direction (STOP) for approximately 2 seconds, and try once more after ending clip linking.

Using time data

The camera-recorder provides time data such as time codes, user bits, time of day (real-time) data, which is recorded on each frame alongside video data. It is also recorded as data in clip metadata files.

Counter setting and display

Pressing the COUNTER button to view the counter displays the counter value on the time code indicator in the LCD and in the viewfinder. (Page 121)

The counter value is indicated in “Hour : Minute . Second” format. The counter value is not displayed during playback.

The menu option REC COUNTER in the DISPLAY SETUP screen can be set to display two types of counters. (Page 149)

TOTAL:

provides a continuous count until reset by pressing the COUNTER RESET button. The counter value is retained when P2 cards are replaced and when the power is turned off.

CLIP:

The counter is reset to 0 at the start of each recording and allows you to keep track of clip recording time while shooting the current clip.

- **Pressing the RESET button when the counter value is displayed resets the counter to 0.**
- **The counter value indicates values in the range between 0:00.00 and 9:59.59 in 1-second steps.**

Time data overview

■ Time code

Use the TCG switch to select Rec Run or Free Run mode. (Page 141)

FREE RUN:

The time code advances constantly whether the camera-recorder is on or not just like time itself. Recording using a slave-locked time code input to the TC IN/OUT or DVCPRO/DV connectors is also possible.

REC RUN:

The time code advances only during recording. This will enable continuation of time codes in previously recorded clips and when the power is turned off or new P2 cards are inserted to continue recording.

The following events will disrupt time code continuity.

- **When clips are deleted**
- **When a 24P or 24PA frame rate is selected**
- **When 24PN or 30PN (25PN) is selected**
- **When a recording is interrupted by a REC WARNING or other abnormality**

■ User bits

- Two types of user bits are provided internally: (LTC UB: recorded as LTC, output via the TC IN/OUT connector as LTC embedded in HD SDI) and VITC (in DVCPRO recorded in the VIDEO AUX area and output as VITC embedded in HD SDI).
- LTC UB enables the recording of user settings, time, date, time codes and similar values, the frame rate data for camera capture and external input values (via TC IN/OUT or DVCPRO/DV connector input).
- VITC user bits record the frame rate data of camera capture.
- The user bits in clip metadata record the LTC UB value at the start of recording.

Using time data (continued)

■ Date (real time)

- The built-in clock calculates the year, month, day and time from the internal clock to display on video in the LCD, viewfinder and VIDEO OUT and other video output.
- The internal clock is not only used to calculate the free run time code when the power is off and to set the user bit year, date and time, but also to set file creation dates when clips are recorded that determine the order of thumbnails and playback order.
- It is also used for generating clip metadata and UMID (Unique Material Identifier).
 - “Setting the calendar” (Page 26 of Vol. 1)

Setting user bits

Use the setting menu UB MODE on the RECORDING SETUP screen to select the user bits to record in the subcode area. (Page 142)

USER:

Records internal user values. To set user values, set the menu UB PRESET screen. Set values are retained after the power is turned off.

- “Entering the user bits” (Page 63)

TIME:

Records the time calculated by the internal clock.

DATE:

Records the year, month and day time digits from the internal clock.

EXT:

Records the user bits input to the TC IN/OUT connector.

Recording of 1394 input also records user bits input to the DVCPRO/DV connector.

TCG:

Records the time code value.

FRM. RATE:

Records the frame rate information of camera capture.

A native recorded clip is played back at the same frame rate as the VITC UB regardless of recorded values. Use this setting when a PC or other editing device is to use the user bit frame rate.

- “Frame rate information recorded in user bits” (Page 64)
- To slave lock to the user bits input to the TC IN/OUT connector, set to EXT.
- In slave mode, the UB indicator is highlighted.

- A slave relationship, once started, continues even after input from the TC IN/OUT or DVCPRO/DV connector ends. Note that the following events release user bit slave status.
 - When a UB MODE option is set to something other than EXT.
 - When UB PRESET is performed
 - When switching to 1394 in the menu option REC SIGNAL in the SYSTEM SETUP screen.
 - Turning the power off.
- The internal user value retains the slave values even after slave release.

To input an external time code from the TC IN/OUT terminal, it is necessary to set TC IN/OUT SEL on the setting menu OUTPUT SEL screen to TC IN.

Entering the user bits

The user bits allow information, including memos that use up to eight-digit hexadecimal numbers (date and time), to be recorded in the Subcode area.

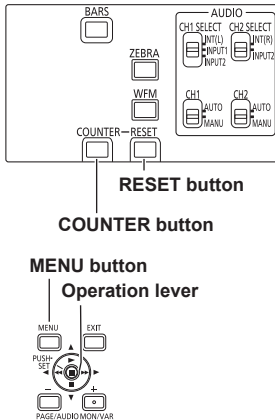

1 Open the setting menu RECORDING SETUP screen and set the menu option UB MODE to USER.

- For details on menu operation, refer to "Using the setup menus" (Page 28 of Vol. 1).
- You can also use the corresponding buttons on the remote control. For details, see "Description of parts" (Remote control). (Page 19 of Vol. 1)

2 Select CHANGE for UB PRESET on the setting menu RECORDING SETUP screen and press SET on the Operation lever to open the User's Bit setting screen.

3 Use Operation lever to set the user bits.

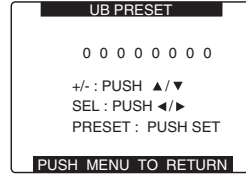

- ▶ direction: Shifts the target (highlighted) digit to the right.
- ◀ direction: Shifts the target (highlighted) digit to the left.
- ▲ direction: Increases the highlighted number by one.
- ▼ direction: Decreases the highlighted number by one.

SET: Confirms the set user bits.

- Pressing the RESET button while setting the user bits will reset any user bit setting to 0.

4 Press SET on the Operation lever and confirm the user's bit setting value and you leave the user's bit setting screen.

If you leave the user's bit setting screen without pressing SET on the Operation lever, the set value is not retained.

5 Use the COUNTER button to display the UB and confirm that the value set is displayed.

Retaining the user bits

The data set for the user bits are automatically saved and retained even if the video camera-recorder is turned off.

Using time data (continued)

Frame rate information recorded in user bits

The frame rate value of video data captured and recorded at a frame rate set in the menu option FRAME RATE or other options in the SYSTEM SETUP screen can be recorded in the user bits and be used in editing equipment (personal computer editing software).

This type of data is recorded in VITC UB at all times.

Setting the setting menu UB MODE to FRM RATE, records the information also to the user bits.

The same value as in the frame rate information obtained from VITC UB playback is also output as LTC UB during playback of clips recorded in native format.

■ Frame rate information

Frame rate, video pull-down and time code user bits are related as described below.

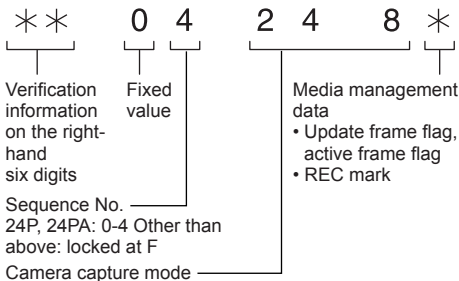

Example:

- 60i: 600
- 60P: 608
- 30P: 308
- 24P: 248
- 24PA: 24C
- 24PN: 24C (recording)
- 50i: 502
- 50P: 50A
- 25P: 25A
- **P: **9 (VFR 30PN or over 60P)
- **P: **1 (VFR over 60P)
- **P: **D (VFR 24PN recording)
- **P: **B (VFR 25PN or over 50P)
- **P: **3 (VFR over 50i)

1080i, 480i, 576i mode

Frame rate: 24P over 60i (2:3)

■ First field of updated frame rate

Time code digit

00	01	02	03	04	05	06	...	23	24	25	26	27	28	29
----	----	----	----	----	----	----	-----	----	----	----	----	----	----	----

Video

A0	A1	B0	B1	B2	B3	C0	C1	D0	D1	A2	A3	B4	B5	...	C2	C3	D2	D3	A4	A5	B6	B7	C4	C5	D4	D5
----	----	----	----	----	----	----	----	----	----	----	----	----	----	-----	----	----	----	----	----	----	----	----	----	----	----	----

Sequence No.

0	1	2	3	4	0	1	...	3	4	0	1	2	3	4
---	---	---	---	---	---	---	-----	---	---	---	---	---	---	---

Updated frame information

10	10	01	01	00	10	10	...	01	00	10	10	01	01	00
----	----	----	----	----	----	----	-----	----	----	----	----	----	----	----

Frame rate: 24PA over 60i (2:3:3:2)

Time code digit

00	01	02	03	04	05	06	...	23	24	25	26	27	28	29
----	----	----	----	----	----	----	-----	----	----	----	----	----	----	----

Video

A0	A1	B0	B1	B2	B3	C0	C1	D0	D1	A2	A3	B4	B5	...	C2	C3	D2	D3	A4	A5	B6	B7	C4	C5	D4	D5
----	----	----	----	----	----	----	----	----	----	----	----	----	----	-----	----	----	----	----	----	----	----	----	----	----	----	----

Sequence No.

0	1	2	3	4	0	1	...	3	4	0	1	2	3	4
---	---	---	---	---	---	---	-----	---	---	---	---	---	---	---

Updated frame information

10	10	01	00	10	10	10	...	00	10	10	10	01	00	10
----	----	----	----	----	----	----	-----	----	----	----	----	----	----	----

Frame rate: 30P over 60i (2:2) 25P over 50i (2:2)

Time code digit

00	01	02	...
----	----	----	-----

Video

A0	A1	B0	B1	C0	...
----	----	----	----	----	-----

Updated frame information

10	10	10	...
----	----	----	-----

720P mode

Frame rate: 24P over 60P (2:3)

Updated frame

Time code digit

00	01	02	03	04	05	06	...	23	24	25	26	27	28	29
----	----	----	----	----	----	----	-----	----	----	----	----	----	----	----

Video

A	A	B	B	B	C	C	D	D	D	A	A	B	B	...	C	D	D	D	A	A	B	B	B	C	C	D	D	D
---	---	---	---	---	---	---	---	---	---	---	---	---	---	-----	---	---	---	---	---	---	---	---	---	---	---	---	---	---

Updated frame information

10	10	01	01	00	10	10	...	01	00	10	10	01	01	00
----	----	----	----	----	----	----	-----	----	----	----	----	----	----	----

Frame rate: 30P over 60P (2:2)

25P over 50P (2:2)

Time code digit

00	01	02	...
----	----	----	-----

Video

A	A	B	B	C	C	...
---	---	---	---	---	---	-----

Updated frame information

10	10	10	...
----	----	----	-----

Setting the time code

- 1 Switch the menu option TC MODE and TCG on the RECORDING SETUP screen to set the mode of the time code.

- **TC MODE (in the case of 59.94 Hz) (Page 141)**

Sets DF/NDF.

Time code	Setting
Drop frame mode	DF
Non-drop frame mode	NDF

24P, 24PA, and 24PN always operate using NDF.

- **TCG (Page 141)**

Sets FREE RUN/REC RUN.

- 2 Select CHANGE for TC PRESET on the setting menu RECORDING SETUP screen and press SET on the Operation lever to open the time code setting screen.

- 3 Use the Operation lever to set the time code.

- Range of available time code settings:
00:00:00:00 to 23:59:59:29 (60i, 60P),
00:00:00:00 to 23:59:59:23 (24PN),
00:00:00:00 to 23:59:59:24 (50i, 50P)

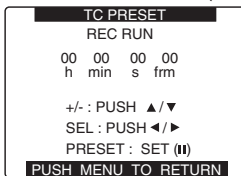

- ▶ direction: Shifts the target (highlighted) digit to the right.
- ◀ direction: Shifts the target (highlighted) digit to the left.
- ▲ direction: Increases the highlighted number by one.
- ▼ direction: Decreases the highlighted number by one.

SET: Use to confirm set time code value.

- Pressing the RESET button will reset any time code setting to 0.

- 4 Press SET on the Operation lever and confirm the time code setting value and you leave the time code setting screen.

- 5 Select TC display using the COUNTER button, and confirm that the value set is displayed.

- When 24P or 24PA is used, the time code is adjusted every 5 frames. It is adjusted to multiples of four for 24PN and to even numbers for 720/30PN. It is adjusted so that the seconds plus the frames are an even number for 720/25PN. The time code cannot be set during recording.
- If you leave the time code setting screen without pressing the SET button on the Operation lever, the set value is not retained.

Time code function during battery replacement

Even during battery replacement the backup mechanism keeps the time code generator functioning.

When the POWER/MODE switch has been switched ON → OFF → ON, the backup accuracy of the time code in free run mode is about ±2 frames.

VFR (variable frame rate) time code

- In 24PN mode, recording is performed at 24-frame time code, and output is performed at 30-frame time code to match the 2:3 pull-down scheme used for video output.
- At a frame rate (capture frame rate) of 24P in 24PN mode, the speed of recording and the output time code matches actual time, but not at any speed other than 24P. (Example: at 60P recording progresses at 60/24 speed)
- Then the camera-recorder operates in REC RUN mode and the time code output at start of recording matches the recording time code.
- This is also the same when shooting in modes other than 30P in 30PN, and 25P in 25PN.

Externally locking the time code

The time code generator built into your AG-HPX250P/EN may be locked to an external generator. It is also possible to lock an external time code generator to the internal generator.

Connections for externally locking the time code (examples)

As illustrated, both the reference video signals and the time code must be input.

■ Example 1: Locking the time code to external signals

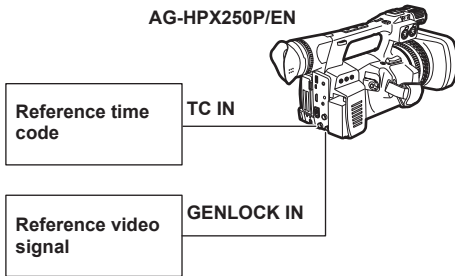

- To input an external time code, set TC IN/OUT SEL on the setting menu OUTPUT SEL screen to TC IN, and TCG on the RECORDING SETUP screen to FREE RUN.
- In addition to an HD Y reference signal, a composite video signal can also be input as reference signal.
- Input composite video signals when the system mode is 480i (576i) (SD) and 720P.
- During HD-Y signal input in 720P system mode, GENLOCK input for the video signal is applied but the time code is delayed by 1 field.
- If the reference GENLOCK input signal becomes irregular and recording cannot be normally performed, "TEMPORARY PAUSE IRREGULAR FRM SIG" blinks in red in the viewfinder and on the LCD screen and the current clip is divided. The continuity of the time code cannot be guaranteed. Recording resumes when the signal returns to normal. Recording will not resume if interval, one-shot or loop recording is in progress.

■ Example 2: Connecting two or more AG-HPX250P/EN with one another, with one being used as the reference device

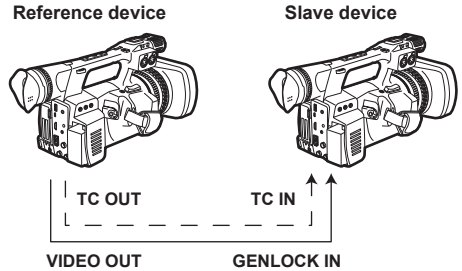

- Set TC IN/OUT terminal to output or input using TC IN/OUT SEL on the setting menu OUTPUT SEL screen.
- For each unit, set TC VIDEO SYNC on the setting menu OUTPUT SEL screen to RECORDING, and GL PHASE on the OTHER FUNCTIONS screen to COMPOSITE.
- If you set TC VIDEO SYNC on the setting menu OUTPUT SEL screen to RECORDING, you can attach the same time code to synchronized video on two units when recording.
- The subcarrier in the VBS signal of the VIDEO OUT connector of the camera-recorder cannot be externally locked.

Using time data (continued)

To externally lock the time code

Follow the steps below.

- 1** Turn the **POWER/MODE** switch to **ON**.
- 2** Set **TCG** on the setting menu **RECORDING SETUP** screen to **FREE RUN**.
- 3** Use the **COUNTER** button to set **TC** display.
- 4** Supply a phase-relationship reference time code (that conforms to the time code requirements) and reference video signals to the **TC IN/OUT** and **GENLOCK IN** connectors, respectively.

- Now the built-in time code generator is locked to the reference time code.
 - When locked to an external time code generator, the time code is at all times locked to the external time code, which is displayed as a highlighted value on the counter indicator. Do not engage the recording mode during the few seconds it takes for the sync generator to stabilize.
 - Once a slave relationship is established, the **TC IN/OUT** and **GENLOCK IN** connectors stay in slave status.*
 - When **TC PRESET** is performed.
 - When the **REC SIGNAL** option in the **SYSTEM SETUP** screen is set to **1394**.
 - The power is turned off.
 - The time code mode is switched.
 - The **TCG** switch is set to **R-RUN**.
 - When **REC FORMAT** and **CAMERA MODE** have been switched.
- * The slave function is a state whereby the unit's internal time code generator is locked to and progresses with an externally input time code, and continues to progress after input of the external time code has stopped.

Setting the user bits when the time code is externally locked

To externally lock user bits, set the setting menu **UB MODE** (**RECORDING SETUP** screen) to **EXT**. Regardless of an **FREE RUN** or **REC RUN** setting, the time code is slaved to user bit values input to the **TC IN/OUT** connector.

- "Time data overview" (Page 61) ·
"Setting user bits" (Page 62)

To unlock the externally locked time code

Discontinue external time code supply, then set the setting menu **TCG** (**RECORDING SETUP** screen) to **REC RUN**.

External synchronisation of the camera when the time code is externally locked

When the time code is externally locked, the reference video signals input through the **GENLOCK IN** connector gen-lock the camera.

-
- To lock other devices externally to the **AG-HPX250P/EN**, as the master device, make sure that the other devices are in the same camera mode as the **AG-HPX250P/EN**. Note that if some of the connected devices use interlaced scanning while other devices use progressive scanning, there may be breaks in the video and time code.
 - When **24P**, **24PA** or **24PN (native)** is selected and the time code is externally locked, be sure to select a non-drop frame time code. The time code cannot be externally locked when drop frame mode is selected. When the time code is externally locked, the video may be distorted, but this is because of adjustment to 5-frame segments and not a malfunction.
-

GENLOCK and time code input/output connection and setup

Camera-recorder operating conditions			Camera-recorder setup	GENLOCK input and camera-recorder output phase (In phase: √ Out of phase: ×)		
Recording format	Video and reference signal to be output externally	GENLOCK input	GL PHASE	SDI OUT (HD)	VIDEO OUT, SDI OUT (SD)	TC OUT
1080i	SDI OUT (1080i)	1080i	HD SDI	√	90H delay	√
	VIDEO OUT		COMPOSITE	90H advance	√	√
	SDI OUT (1080i)	SD (480i/576i)	HD SDI	√	90H delay	√
	VIDEO OUT		COMPOSITE	90H advance	√	√
720P	SDI OUT (720P)	720P	HD SDI	√	120H delay	×
	VIDEO OUT		COMPOSITE	120H advance	√	×
	SDI OUT (720P)	SD (480i/576i)	HD SDI	√	120H delay	√
	VIDEO OUT		COMPOSITE	120H advance	√	√
480i/576i	SDI OUT (480i/576i)	SD (480i/576i)	Disabled	No output	√	√
	VIDEO OUT					

Using time data (continued)

Outputting the time code externally

To output time code from the camera-recorder's TC OUT connector to a VTR or other recording device in sync with camera-recorder picture or playback picture, set the setting menu TC VIDEO SYNC (OUTPUT SEL) to VIDEO OUT.

Set the menu option GL SELECT to HD SDI or COMPOSITE as required by supplied video output in the OTHER FUNCTIONS screen and the menu option TC OUT to TCG/TCR in the OUTPUT SEL screen.

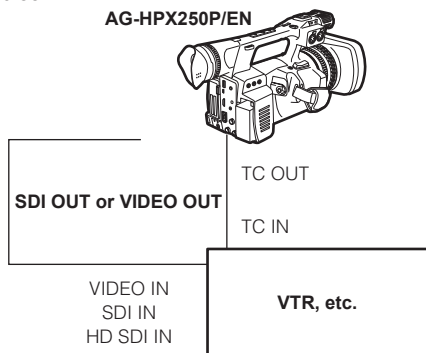

When the setting menu TC VIDEO SYNC is set to VIDEO OUT, the time code is output via TC IN/OUT in tune with VIDEO OUT delay.

Recording time codes and user bits

When SYSTEM MODE is set to 1080-59.94i, 720-59.94P, 480-59.94i

System setting status					Recorded TC		Output TC		Displayed TC	Recorded UB		Output UB			
SYSTEM MODE	REC SIGNAL	REC FORMAT	CAMERA MODE	FRAME RATE	LTC	VITC	TC OUT	LTC and VITC embedded in HD SDI	TC tc (24/30 conversion)	LTC UB	VITC UB	TC IN/OUT connector UB ¹	LTC UB embedded in HD SDI ¹	VITC UB embedded in HD SDI	
1080-59.94i	CAMERA	DVCPROHD/60i	60i, 30P	---	R-RUN/F-RUN ³ DF/NDP 30 frames	Same as LTC value	Outputs LTC	Outputs LTC	TC tc: 30 frames tc: 24 frames	Follows UB MODE. -In 'EXT' slaves to UB in TC IN/OUT connector	Frame rate data	Outputs LTC UB	Outputs LTC UB	Frame rate data	
				1 to 30 FRAME											
			24P, 24PA	---	R-RUN/F-RUN ⁵ NDP locked 30 frames										

			AVC-1100/60i AVC-150/60i	---	---										R-RUN/F-RUN ³ DF/NDP 30 frames
					1 to 30 FRAME										
		AVC-1100/30PN AVC-150/30PN	---	---	R-RUN/F-RUN ³ DF/NDP 30 frames										
				30 FRAME											
			Other than 30 FRAME	R-RUN locked DF/NDP Every active frame 30 frames											

AVC-1100/24PN AVC-150/24PN	---	---	R-RUN/F-RUN ⁷ NDP locked 24 frames												
		24 FRAME													
	Other than 24 FRAME	R-RUN locked NDP locked Every active frame 24 frames													

1394	DVCPROHD/60i	---	---	R-RUN/F-RUN ² DF/NDP 30 frames	Records VAUX TC in 1394 input at all times ⁶	Outputs LTC	Outputs LTC	TC: 30 frames tc: 24 frames	Follows UB MODE. -In 'EXT' slaves to LTC UB in 1394 input	Records VITC UB in 1394 input at all times	Outputs LTC UB	Outputs LTC UB	Outputs VITC UB		

*1: When UB MODE is FRM. RATE, playback of native clips is the pulldown frame rate read from VITC UB.

*2: In Free Run mode, it is slaved to the value input to the DVCPRO/DV connector. It does not slave it to the time code from the TC IN/OUT connector.

*3: In Free Run mode, it is slaved to the time code input to the TC IN/OUT connector.

*5: In Free Run mode, it is slaved when TC input to the TC IN/OUT connector is non-drop frame. But not slaved to it during recording.

*6: VAUX TC is time code recorded in the video AUX area in the DVC format.

*7: In Free Run mode, it is slaved to the time code input to the TC IN/OUT connector, whose value is converted to 24 frames when it was NDP 30 frames. But not slaved to it during recording.

Using time data (continued)

System setting status					Recorded TC		Output TC		Displayed TC	Recorded UB		Output UB		
SYSTEM MODE	REC SIGNAL	REC FORMAT	CAMERA MODE	FRAME RATE	LTC	VITC	TC OUT	LTC and VITC embedded in HD SDI	TC tc (24/30 conversion)	LTC UB	VITC UB	TC IN/OUT connector UB*	LTC UB embedded in HD SDI*	VITC UB embedded in HD SDI
720 59.94P	CAMERA	DVCPROHD/60P AVC-1100/60P AVC-150/60P	---	Other than 24 FRAME	R-RUN/F-RUN ³ DF/NDP 30 frames	Same as LTC value	Outputs LTC	Outputs LTC	TC: 30 frames tc: 24 frames	Follows UB MODE. -In 'EXT' slaves to UB in TC IN/OUT connector	Frame rate data	Outputs LTC UB	Outputs LTC UB	Frame rate data
			---	24 FRAME	R-RUN/F-RUN ³ NDF locked 30 frames									
		DVCPROHD/30PN AVC-1100/30PN AVC-150/30PN	---	30 FRAME	R-RUN/F-RUN ⁴ DF/NDP Every active frame 30 frames									
			---	Other than 30 FRAME	R-RUN locked DF/NDP Every active frame 30 frames									
		DVCPROHD/24PN AVC-1100/24PN AVC-150/24PN	---	24 FRAME	R-RUN/F-RUN ⁷ NDF locked Every active frame 24 frames									
			---	Other than 24 FRAME	R-RUN locked NDF locked Every active frame 24 frames									
1394	DVCPROHD/60P	---	---	R-RUN/F-RUN ² DF/NDP 30 frames	Records VAUX TC in 1394 input at all times ¹	Outputs LTC	Outputs LTC	TC: 30 frames tc: 24 frames	Follows UB MODE. -In 'EXT' slaves to LTC UB in 1394 input	Records VITC UB in 1394 input at all times	Outputs LTC UB	Outputs LTC UB	Outputs VITC UB	
480 59.94i	CAMERA	DVCPRO50/60i DVCPRO/60i DV/60i	60i, 30P	---	R-RUN/F-RUN ³ DF/NDP 30 frames	Same as LTC value (but not for DV)	Outputs LTC	No input	TC: 30 frames tc: 24 frames	Follows UB MODE. -In 'EXT' slaves to UB in TC IN/OUT connector	Frame rate data	Outputs LTC UB	No input	No input
			24P, 24PA	---	R-RUN/F-RUN ³ NDF locked 30 frames									
	1394	---	---	---	R-RUN/F-RUN ² DF/NDP 30 frames	Records VAUX TC in 1394 input at all times ¹	Outputs LTC	No input	TC: 30 frames tc: 24 frames	Follows UB MODE. -In 'EXT' slaves to LTC UB in 1394 input	Records VITC UB in 1394 input at all times	Outputs LTC UB	No input	No input

*1: When UB MODE is FRM. RATE, playback of native clips is the pulldown frame rate read from VITC UB.

*2: In Free Run mode, it is slaved to the value input to the DVCPRO/DV connector. It does not slave it to the time code from the TC IN/OUT connector.

*3: In Free Run mode, it is slaved to the time code input to the TC IN/OUT connector.

*4: In Free Run mode, it is slaved to the time code input to the TC IN/OUT connector. But not slaved to it during recording.

*5: In Free Run mode, it is slaved when TC input to the TC IN/OUT connector is non-drop frame. But not slaved to it during recording.

*6: VAUX TC is time code recorded in the video AUX area in the DVC format.

*7: In Free Run mode, it is slaved to the time code input to the TC IN/OUT connector, whose value is converted to 24 frames when it was NDF 30 frames. But not slaved to it during recording.

When SYSTEM MODE is set to 1080-50i, 720-50P, 573-50i

System setting status					Recorded TC		Output TC		Displayed TC	Recorded UB		Output UB		
SYSTEM MODE	REC SIGNAL	REC FORMAT	CAMERA MODE	FRAME RATE	LTC	VITC	TC OUT	LTC and VITC embedded in HD SDI	TC Ic (24/30 conversion)	LTC UB	VITC UB	TC IN/OUT connector UB ^{*1}	LTC UB embedded in HD SDI ^{*1}	VITC UB embedded in HD SDI ^{*1}
1080-50i	CAMERA	DVCPROHD/50i	50i, 25P (50i)	— 1 to 25 FRAME	R-RUN/F-RUN ³ 25 frames	Same as LTC value	Outputs LTC	Outputs LTC	TC: 25 frames	Follows UB MODE. -In 'EXT' slaves to UB in TC IN/OUT connector	Frame rate data	Outputs LTC UB	Outputs LTC UB	Frame rate data
		AVC-1100/50i AVC-150/50i	—	1 to 25 FRAME										
	AVC-1100/25PN AVC-150/25PN	—	— 25FRAME	R-RUN/F-RUN ³ 25 frames	R-RUN locked Every active frame 25 frames	Matches recorder TC at start of recording 25 frames/s	Matches recorder TC at start of recording 25 frames/s							
		Other than 25 FRAME												
1394	DVCPROHD/50i	—	—	R-RUN/F-RUN ² 25 frames	Records VAUX TC in 1394 input at all times ^{*6}	Outputs LTC	Outputs LTC	TC: 25 frames	Follows UB MODE. -In 'EXT' slaves to LTC UB in 1394 input	Records VITC UB in 1394 input at all times	Outputs LTC UB	Outputs LTC UB	Outputs VITC UB	
720-50P	CAMERA	DVCPROHD/50P AVC-1100/50P AVC-150/50P	—	1-50 FRAME	R-RUN/F-RUN ³ 25 frames	Same as LTC value	Outputs LTC	Outputs LTC	TC: 25 frames	Follows UB MODE. -In 'EXT' slaves to UB in TC IN/OUT connector	Frame rate data	Outputs LTC UB	Outputs LTC UB	Frame rate data
		—	25 FRAME	R-RUN/F-RUN ⁴ Every active frame 25 frames										
	DVCPROHD/25PN AVC-1100/25PN AVC-150/25PN	—	Other than 25 FRAME	R-RUN locked Every active frame 25 frames	Matches recorder TC at start of recording 25 frames/s	Matches recorder TC at start of recording 25 frames/s								
1394	DVCPROHD/50P	—	—	R-RUN/F-RUN ³ 25 frames	Records VAUX TC in 1394 input at all times ^{*6}	Outputs LTC	Outputs LTC	TC: 25 frames	Follows UB MODE. -In 'EXT' slaves to LTC UB in 1394 input	Records VITC UB in 1394 input at all times	Outputs LTC UB	Outputs LTC UB	Outputs VITC UB	
576-50i	CAMERA	DVCPRO50i DVCPRO/50i DV/50i	50i, 25P	—	R-RUN/F-RUN ³ 25 frames	Same as LTC value (but not for DV)	Outputs LTC	No input	TC: 25 frames	Follows UB MODE. -In 'EXT' slaves to UB in TC IN/OUT connector	Frame rate data	Outputs LTC UB	No input	No input
		1394	—	—	R-RUN/F-RUN ² 25 frames	Records VAUX TC in 1394 input at all times (but not for DV) ^{*6}	Outputs LTC		TC: 25 frames	Follows UB MODE. -In 'EXT' slaves to LTC UB in 1394 input	Records VITC UB in 1394 input at all times	Outputs LTC UB		

*1: When UB MODE is FRM. RATE, playback of native clips is the pulldown frame rate read from VITC UB.

*2: In Free Run mode, it is slaved to the value input to the DVCPRO/DV connector. It does not slave it to the time code from the TC IN/OUT connector.

*3: In Free Run mode, it is slaved to the time code input to the TC IN/OUT connector.

*4: In Free Run mode, it is slaved to the time code input to the TC IN/OUT connector. But not slaved to it during recording.





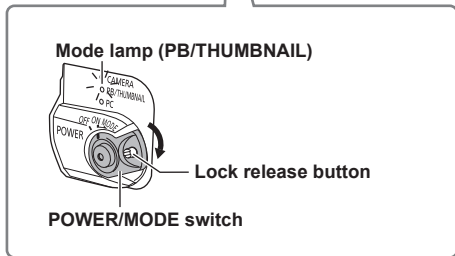
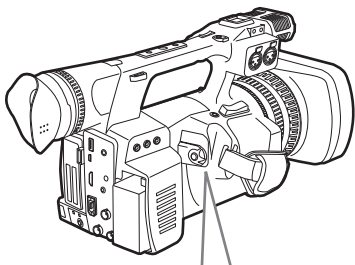





*6: VAUX TC is time code recorded in the video AUX area in the DVC format.

Basic playback operations



- 1 Turn the **POWER/MODE** switch to **ON**.
While holding down the lock release button, turn the POWER/MODE switch to the ON position.
- 2 Turn the **POWER/MODE** to illuminate the **PB/THUMBNAIL** operation lamp.
The camera-recorder is now in the PB/THUMBNAIL mode.
 - Each time you press the button, the mode changes as below.
PB/THUMBNAIL ⇄ CAMERA
Turning and holding the POWER/MODE switch downward for about 2 seconds after entering PB/THUMBNAIL mode switches to PC (Personal Computer connection) mode. (Page 109)

For details on playing back clips using thumbnails, see page 75.

Operations using the Operation lever	Remote Control
 <p>Play (▶) Use this to play back the selected clip <u>when playback has been stopped</u>. <u>During playback</u>, the unit enters the variable speed search mode and starts 1x playback. (Page 99)</p>	
 <p>Fast-forward (▶▶) Use this button <u>during playback</u> to fast-forward the selected clip (4 x speed). When the thumbnail screen is cancelled, you can also perform this operation while the camera-recorder is stopped. When this button is held down, the playback speed becomes faster (32 x speed). When pressed <u>during a pause</u>, playback advances one clip.</p>	
 <p>Rewind (◀◀) Use this button <u>during playback</u> to rewind the selected clip (4 x speed). When the thumbnail screen is cancelled, you can also perform this operation while the camera-recorder is stopped. When this button is held down, the playback speed becomes faster (32 x speed). When pressed <u>during a pause</u>, playback goes back one clip.</p>	
 <p>Stop (■) Press this button <u>during playback/pause</u> to halt the operation and return to the thumbnail screen.</p>	
 <p>Pause () Press again to return to playback.</p>	

Thumbnail operations

A clip is a data group that includes the images and voices created from one shooting session, together with additional information such as text memos and meta data.

On this unit, thumbnails of all clips are displayed on the LCD monitor by switching to PB/THUMBNAIL mode.

You can carry out the operations below by using the Operation lever on the thumbnail screen.

- Playback, delete, copy or restore the clip.
- Add or delete a shot mark and a text memo on the clip thumbnail.
- Copy part of a clip by using the text memo.
- Change the thumbnail image by using the text memo.
- Format P2 cards and SD memory cards.
- Uploading and editing clip metadata from the SD memory card

Thumbnail operations (continued)

Thumbnail manipulations overview

Thumbnail screens are configured as follows:



THUMBNAIL



- ALL CLIP
- SAME FORMAT CLIPS
- SELECTED CLIPS
- MARKED CLIPS
- TEXT MEMO CLIPS



- SLOT CLIPS
- SET UP
- EXIT

OPERATION



- DELETE
- REFORMAT
- REPAIR CLIP
- RE-CONNECTION
- COPY
- EXCH. THUMBNAIL
- EXIT

PROPERTY



CLIP PROPERTY

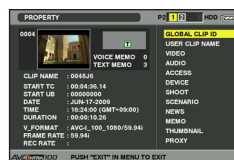

CARD STATUS

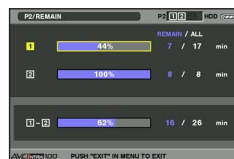

- DEVICES
- PROPERTY SETUP
- EXIT

META DATA

- LOAD
- RECORD
- USER CLIP NAME
- INITIALIZE
- PROPERTY
- EXIT

HDD

- EXPORT
- EXPLORE
- SETUP
- EXIT

Thumbnail screen

The thumbnail screen is displayed on the LCD monitor when you turn the POWER/MODE switch downward and switch to PB/THUMBNAIL mode.

Turn the POWER/MODE switch again to return to CAMERA mode.

After changing from CAMERA mode to the thumbnail screen, all clips are displayed on the thumbnail screen.

Pressing the MENU button allows you to navigate the thumbnail menu.

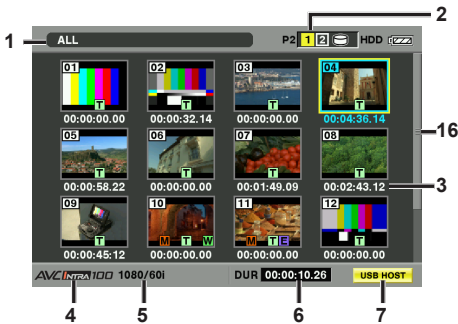

Thumbnail screen



Clip icons

1. Display Mode

The type of the thumbnail indicated on the display and the types of the other information screens are indicated.

ALL:

Display all clips.

SAME FORMAT:

Clips in the same format as the system format (SYSTEM MODE item, REC FORMAT item) are shown.

- Refer to page 135 for each item.

SELECT:

The clips selected with the SET button are shown.

MARKER:

Display clips with shot marks.

TEXT MEMO:

Display clips with text memo data.

SLOT n:

Display clips in the specified P2 card. (n: 1 or 2, which indicates Slots 1 or 2.)

UPDATING..:

Indicated when the camera-recorder is updating the screen or reading data. When the screen is being updated, the rotating icon  is indicated.

- “Switching the thumbnail display” (Page 80)

(Continued on the next page)

2. Slot numbers and HDD status

This section indicates on which P2 card the pointed clip is recorded. The number of the slot that contains the appropriate P2 card is indicated in yellow. If the clip is recorded on more than one P2 card, then the numbers of all slots that contain the appropriate cards are indicated. The numbers of the other slots are shown in white if they contain P2 cards. When the following P2 card is inserted, the slot number is displayed with a pink frame.

- **RUN DOWN CARD**
(A P2 card on which the maximum number of overwrites has been exceeded.)
- **DIR ENTRY NG CARD**
(A P2 card on which the directory structure is not supported.)

The USB HDD section is indicated as follows:

- Other than the USB HOST mode: gray
- Not connected in USB HOST mode: gray
- HDD recognized and usable in USB HOST mode: white
- HDD recognized and thumbnails shown in USB HOST mode: yellow
- HDD recognized and not usable in USB HOST: red

3. Time Display

You can set this to display the time code at the start of clip recording (TC), the user bits at the start of clip recording (UB), the shooting time (TIME), the shooting date (DATE), the shooting time date and time (DATE TIME), the clip name (CLIP NAME) or the user clip name (USER CLIP NAME).

- "Setting the thumbnail display mode" (Page 92)

4. Recording mode

The recording mode for the clip on which the pointer is located is indicated.

5. System format

The format for the clip on which the pointer is located is indicated.

6. Duration

The duration of the clip on which the pointer is located is indicated.

7. USB HOST mode indicator

Indicated when the mode has been switched to USB HOST.

8. Clip Number

The numbers set by the camera-recorder for all the clips recognised correctly by the P2 card. These numbers are allocated in chronological order, by shooting dates and times.

If clips cannot be played because of different recording formats, they are displayed in red.

9. Defective Clip Indicator and

Unknown Clip indicator

This marker is displayed for defective clips, which may result from a variety of causes, e.g., powering-down during recording.

Clip with yellow defective clip indicators can be restored in some cases.

- "Restoring clips" (Page 85)

A clip displayed with a red corrupt marker cannot be restored and must be deleted. If the clip cannot be deleted, format the P2 card.

 is displayed for clips such as those which differ in format from the P2 standard.

10. Incomplete Clip Indicator

Indicates that although a clip is recorded across multiple P2 cards, one of these cards is not inserted into a P2 card slot.

11. Shot Mark Indicator

This marker is displayed for a clip with a shot mark attached.

- "Shot mark" (Page 82)

12. Indicator for clips with proxy

This is displayed on clips for which proxy recorded on a proxy supporting P2 camera recorder such as an AJ-HPX3100 is attached.

13. Text Memo Indicator

This marker is displayed for a clip with a text memo attached.

14. Edit Copied Clip Indicator

This marker is displayed on a clip when the model supports edit copy, such as the AJ-HPM200. For more information about edit copying, see the instruction manual for a mode that supports edit copying.

15. Wide Clip Indicator

This marker is displayed for clips recorded with the 16:9 aspect ratio. However, it does not accompany clips in HD format.

16. Thumbnail Scroll Bar

Indicates which part of the whole thumbnail is currently being viewed.

Selecting thumbnails

Multiple thumbnails can be randomly selected in the thumbnail screen.

- 1 Push the Operation lever in the ◀ ▶ direction to the clip you wish to select, and press SET.

The frame around the selected thumbnail changes to a blue frame. Press the SET button on the Operation lever again to deselect the clip.

- 2 Additional clips can be selected by repeating Step 1.

It is possible to display only the selected thumbnails in the thumbnail screen for playback.

- “Switching the thumbnail display” (Page 80)

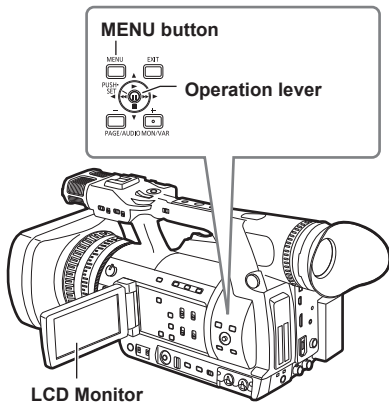

Playing back clips

- 1 Turn the POWER/MODE switch to set to PB/ THUMBNAIL mode.

The thumbnail screen appears on the LCD monitor.

- 2 Push the Operation lever in the ◀ ▶ direction and position the pointer on the clip you wish to play back.

- 3 Push the Operation lever in the ▲ direction (▶ playback).

- The clip under the pointer will be played back on the LCD monitor.
- When playback of the clip over which the cursor is placed is finished, subsequent clips that can be played back are played back in the order they are displayed on the thumbnail screen, and when playback of the final clip is complete the system returns to the thumbnail screen.

- When playing back clips, it is not necessary to “select” the clips (blue frames around the thumbnails).
- Clips with clip numbers displayed in red cannot be played.

- You can perform actions such as fast forward, rewind, and pause during operation by using the Operation lever or remote control. See page 74 for details.
- During clip playback, push the Operation lever in the ▼ direction (STOP) to stop playback and return to the thumbnail screen.

- When playback is stopped, the position of the pointer moves to the clip that was being played back, regardless of where the playback started.
- Push the Operation lever in the ▼ direction (▶ play back) again to start playback from the beginning of the clip under the pointer. To continue playing from where previously stopped, turn the PLAYBACK RESUME setting “ON” in “Setting the thumbnail display mode” on page 92.

Thumbnail operations (continued)

Switching the thumbnail display

The display can be switched so that only those clips matching the specified conditions are displayed in the thumbnail screen.

1 Turn the POWER/MODE switch to set to PB/ THUMBNAIL mode.

The thumbnail screen appears on the LCD monitor.

2 Press the MENU button.

The thumbnail menu appears.

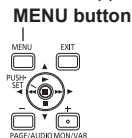

3 Select THUMBNAIL from the thumbnail menu.

Switch the thumbnail display by selecting one of the following items:



ALL CLIP:

Display all clips.

SAME FORMAT CLIPS:

Displays clips of the current system format.

SELECTED CLIPS:

Display randomly selected clips. At this time the thumbnails appear in selected order.

MARKED CLIPS:

Display clips with shot marks attached.

TEXT MEMO CLIPS:

Display clips with text memo data attached.

SLOT CLIPS:

Display clips recorded in the P2 card inserted in the specified slot. When this item is selected, SLOT1 to SLOT2 are displayed as a sub-menu. Select the desired slot to display the clips.

SETUP:

Please refer to "Setting the thumbnail display mode" (Page 92) for information about this item.

EXIT:

Close the sub-menu.

Changing thumbnails

It is possible to replace thumbnails with images that include previously attached text memos while images are recorded or played back.

1 Add text memos to images that you intend to change.

Refer to "Text memo recording" (Page 42) for the method to add text memos.

2 Select THUMBNAIL → TEXT MEMO CLIPS to display thumbnails of the clips with text memos.

3 Place the pointer on the clip of the thumbnail that you intend to change, and then press SET of Operation lever. Move the pointer to the text memo display on the lower row.

4 Select the thumbnail that you intend to replace, place the pointer on it, and then select OPERATION → EXCH. THUMBNAIL on the thumbnail menu.

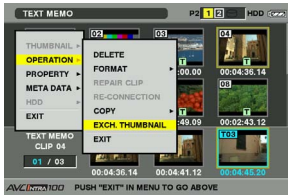

5 A YES/NO confirmation screen is displayed when you press SET on the Operation lever. Use the Operation lever to select YES.

The menu closes and the thumbnail for the clip is replaced.



Display clip properties by selecting **PROPERTY** → **CLIP PROPERTY** on the thumbnail menu to confirm the position of the thumbnail (the number of frames from the top of the clip). Since thumbnails come generally from the top of the clip, [0] is displayed.

Thumbnail operations (continued)

Shot mark

A shot mark can be added to a clip thumbnail to distinguish this clip from the others.

1 Turn the POWER/MODE switch to set to PB/ THUMBNAIL mode.

The thumbnail screen appears on the LCD monitor.

2 Push the Operation lever in the ◀ ▶ direction and position the pointer on the clip you wish to attach a shot mark to.

3 Press the USER button to which the shot mark function has been allocated.

- This adds a shot mark to the thumbnail of the clip at the pointer position.
- To delete a shot mark, position the pointer over the desired clip again and press the USER button to which the shot mark function has been allocated.
- "Using the USER buttons" (Page 39)

-
- **A shot mark can be attached during recording.**
 - **Adding shot marks after recording stops, attaches the shot mark to the most recently recorded clip.**
 - "Shot mark function" (Page 41)
 - **When adding a shot mark to (or deleting the shot mark from) a clip recorded across multiple P2 cards, do this with all these P2 cards inserted into P2 card slots.**
-

Text memo

During recording or playback, you can add text memos to clips. Text memos can be used to play back clips at some point or break clips into chunks and copy the necessary portions.

Adding a text memo

Text memos can be added in one of the following ways.

- During recording/playback, press the USER button to which the text memo function has been allocated.
 - A text memo is attached at the position where the button was pressed. (Page 42)
- Pressing the USER button to which the text memo function has been allocated when the thumbnail screen is displayed adds a text memo at the start of the clip currently indicated by the pointer.
- "Using the USER buttons" (Page 39)

One clip can have up to 100 text and voice memos in combination. Note that camera-recorder is not capable of adding or showing voice memos.

Playing back a clip at the position where a text memo is recorded

- 1 Turn the **POWER/MODE** switch to set to **PB/ THUMBNAIL** mode.

The thumbnail screen appears on the LCD monitor.

- 2 Press the **MENU** button and select **THUMBNAIL** → **TEXT MEMO CLIPS** from the thumbnail menu.

The clip thumbnails with text memos attached are displayed in the upper section of the LCD monitor. The lower section of the LCD monitor shows information about the text memo on the clip selected by the pointer.



Thumbnail Display

Shows the still image that the text memo is related to.

Selected text memo clips (blue) and total clips (white)

- 3 Move the pointer over the clip that contains the desired text memo to playback and press the **SET** button on **Operation** lever.

The pointer moves to the lower part of the LCD monitor.



The pointer moves down.

- 4 With the pointer at the bottom, push the **Operation** lever in the ◀ ▶ direction and position it on the text memo number you wish to play back then push the **Operation** lever in the ▲ direction (▶ playback).

- Playback will start from the time code position of the text memo where the pointer is located. If the **Operation** lever in the ▼ direction (**STOP**) is pressed during playback or the playback has finished at the end of the clip, then the thumbnail screen appears again with the pointer replaced with the text memo where the playback started.
- Press the **MENU** button to select **EXIT** or press the **EXIT** button to return the pointer to the upper part of the thumbnail screen.

- Pressing the **START/STOP** button in the text memo screen will not start recording.
- For **AVC-Intra** format clips that cannot be played back, text memo thumbnails cannot be displayed, and may be shown as a  icon.

Deleting a text memo

- 1 Select the desired text memo by carrying out steps 1–3 for “Playing back a clip at the position where a text memo is recorded” (Left).
- 2 Move the pointer to the desired text memo, and then press the **SET** button on **Operation** lever.
- 3 Press the **MENU** button to select **OPERATION** → **DELETE** from the thumbnail menu.

A **YES/NO** screen appears to confirm that you wish to delete. Select **YES** with the **Operation** lever to delete the text memo.

Thumbnail operations (continued)

Using a text memo to break a clip and copy the necessary portion

- 1 Select a desired text memo in a clip by carrying out steps 1-3 for “Playing back a clip at the position where a text memo is recorded” (Page 83).
- 2 Move the pointer to the desired text memo, and then press the SET button on the Operation lever.
You can select more than one text memo.
- 3 Press the MENU button to select OPERATION → COPY.
- 4 Use the Operation lever and SET buttons to select the destination slot. Then, select YES.
 - Copying starts.
 - The portion between the selected text memo and the next one is copied. If no text memo is found after the selected one, then all part after the selected text memo is copied.
 - If multiple text memos are selected, the selected sections are copied.
 - When the clip is being copied, the camera-recorder indicates the progress of the copy process and cancellation status. To discontinue the copy process, press the SET button on the Operation lever. Then, a YES/ NO confirmation screen is displayed. Use the Operation lever to select YES.

In clip division and copying using the text memo function, the area copied may be automatically modified depending on the recording format of the clip.

Deleting clips

- 1 Turn the POWER/MODE switch to set to PB/ THUMBNAIL mode.
The thumbnail screen appears on the LCD monitor.
- 2 Push the Operation lever in the ◀ ▶ direction and position it on the clip you wish to delete. Press SET on the Operation lever to select the clip.
Multiple clips can be selected.
- 3 Press the MENU button and select OPERATION → DELETE from the thumbnail menu.
- 4 The following screen appears. Use the Operation lever to select YES.

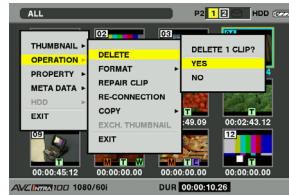

The clip is deleted. All selected clips (in blue-green frames) are deleted by this operation.

To interrupt deleting, press the SET button on the Operation lever to cancel the operation. Partially deleted clips cannot be restored by canceling.

Restoring clips

Restores clips that are defective as a result of sudden powering-down during recording, or removal of the P2 card being accessed.

Only those clips with yellow corrupt clip markers can be restored. Clips with a red corrupt clip indicator cannot be repaired. Please delete such clips. If the clip cannot be deleted, format the P2 card.

During restoration of the clips, however, the defective-clip indicator may change from yellow to red, resulting in inability to restore the clips.

- 1 Turn the POWER/MODE switch to set to PB/ THUMBNAIL mode.**
The thumbnail screen appears on the LCD monitor.
- 2 Push the Operation lever in the ◀ ▶ direction and position it on the clip you wish to restore (clips with the yellow corrupt clip indicator which signifies that they can be restored are displayed). Press SET on the Operation lever to select the clip.**
- 3 Press the MENU button, and select OPERATION → REPAIR CLIP from the thumbnail menu.**
A YES/NO confirmation screen asks you to confirm that you want to repair the clip. Select YES with the Operation lever if you wish to restore the clip.

Reconnection of incomplete clips

Incomplete clips may be generated when clips recorded on multiple P2 cards (connected clips) are separately copied to different cards. Reconnection function generates one clip (the original, connected clip) from incomplete clips.

- 1 Turn the POWER/MODE switch to set to PB/ THUMBNAIL mode.**
The thumbnail screen appears on the LCD monitor.
- 2 Use the Operation lever to select incomplete clips to reconnect.**
Usually, thumbnails of incomplete clips (clips with ■ marker) are displayed in line.
- 3 Press the MENU button and select OPERATION → RE-CONNECTION from the thumbnail menu.**
A YES/NO confirmation screen asks you to confirm that you want to reconnect the clip. Select YES with the Operation lever if you wish to reconnect the incomplete clip.

Clips that are connected as a group must be grouped together or they will be displayed as incomplete clips.

Thumbnail operations (continued)

Copying clips

Selected clips can be copied to the P2 card or SD memory card in the desired slot.

1 Turn the POWER/MODE switch to set to PB/ THUMBNAIL mode.

The thumbnail screen appears on the LCD monitor.

2 Use the Operation lever to move the pointer to the desired clip and press the SET button on the Operation lever.

If recording using the one-clip REC function in which the clip can be combined with the previous clip (when "1*CLIP" is displayed), then copying of clips is not possible.

After changing to CAMERA mode, push the Operation lever in the ▼ direction (STOP) for approximately 2 seconds, and try again after ending clip linking.

3 Press the MENU button and select OPERATION → COPY from the thumbnail menu.

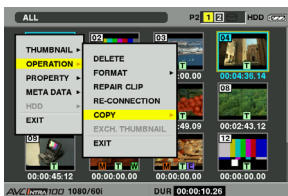

- Select Slot 1–2 or SD memory card as the destination.
- A YES/NO confirmation screen asks you to confirm that you want to copy the clip. Select YES with the Operation lever if you wish to copy the incomplete clip.

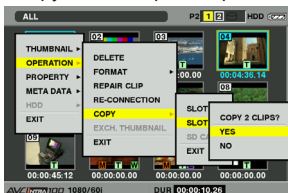

- Do not turn off the power or remove a P2 card while data is being copied. Doing so may cause the P2 card to fail. If you should accidentally perform one of the its operations, defective clips will be generated. Delete them, and then copy them again.
- When clips are copied to P2 cards, all the information on the clips is copied. However, when they are copied to the SD memory card*, video and sound information is not copied, only thumbnails, clip metadata, icons, Voice Memo, proxy, and real-time metadata.
- When there is insufficient recording capacity on the destination, the message "LACK OF REC CAPACITY!" is displayed, and copying will not proceed. When clips to be copied include some with defects, the message "CANNOT ACCESS!" is displayed, and copying will not proceed. If you attempt to copy the clips to the same card, "NO COPY TO SAME CARD!" is displayed and copy is not performed.
- To interrupt copying, press the SET button on the Operation lever. Clips currently being copied to the destination will be deleted.
- When identical clips exist on the destination card, the "OVERWRITE?" is displayed. Select "YES" or "NO".

* Regarding SD memory cards to be used, see <Cautions in using SD memory cards> (Page 162).

Setting of clip meta data

Information such as the name of person who shot the video, the name of the reporter, the shooting location, or a text memo can be read from the SD memory card, and can be recorded as Clip Meta Data.

During display of names of metadata, push the Operation lever in the ► direction to switch to display of file names. Push the Operation lever in the ◀ direction to return to display of metadata names.

Reading clip meta data (metadata upload)

- 1 Insert the SD memory card that contains the Clip Meta Data (metadata upload file).
- 2 Turn the POWER/MODE switch to set to PB/THUMBNAIL mode.
The thumbnail screen appears on the LCD monitor.
Press the MENU button while pressing DISP/MODE CHK switch when a thumbnail is displayed to move to Step 4.
- 3 Press the MENU button and Select META DATA → LOAD from the thumbnail menu, and press the SET button on the Operation lever.



- 4 Names of metadata upload files stored on the SD memory card are displayed. Select the desired files using the Operation lever, and choose YES.
 - Upload starts.
 - Uploaded metadata is retained even if the power is turned off.
 - For confirmation of uploaded data, see “Checking and modifying read metadata” (Page 89).

Thumbnail operations (continued)

Clip meta data items

Clip Meta Data includes the following items: Underlined items can be set by reading the metadata upload file on the SD memory card. Other items are set automatically during shooting. Using the P2 viewer, metadata upload files can be written to SD memory cards using a PC. Download the latest version of the P2 viewer from the following URL and install it to your PC.

<http://pro-av.panasonic.net/>

Regarding SD memory cards to be used, see <Cautions in using SD memory cards> (Page 162).

The file which was edited by except P2 viewer is displayed as “UNKNOWN DATA”, and may not be read.

GLOBAL CLIP ID:

Displays the global clip ID, which indicates the shooting status of the clip.

USER CLIP NAME: *1

Displays the clip name specified by the user.

VIDEO:

Displays [FRAME RATE] (frame rate of the clip), [PULL DOWN], and [ASPECT RATIO].

AUDIO:

[SAMPLING RATE] (sampling frequency of recorded sound) and [BITS PER SAMPLE] (digitized bit[s] of recorded sound).

ACCESS:

Displays [CREATOR] (person who recorded the clip), [CREATION DATE] (date when the clip was recorded), [LAST UPDATE DATE] (date of the latest update of the clip), and [LAST UPDATE PERSON] (person who made the latest update of the clip).

DEVICE:

Displays [MANUFACTURER] (name of the device manufacturer), [SERIAL NO.] (serial number of the device) and [MODEL NAME] (model name of the device).

SHOOT: *2

Displays [SHOOTER] (name of the person who shot the video), [START DATE] (start date of shooting), [END DATE] (end date of shooting), and [LOCATION] ALTITUDE/LONGITUDE/LATITUDE/SOURCE/PLACE NAME (altitude, longitude, latitude, and source of the information and name of the location).

SCENARIO:

Displays [PROGRAM NAME], [SCENE NO.], and [TAKE NO.].

NEWS:

Displays [REPORTER] (name of the reporter), [PURPOSE] (purpose of shooting), and [OBJECT] (object of shooting).

MEMO: *3

Displays [NO.] (the number of the text memo), [OFFSET] (location of the frame where the text memo is added), [PERSON] (person who recorded the text memo added to the clip), and [TEXT] (contents of the text memo).

THUMBNAIL:

Displays the location of the frame (frame offset) and the size (height and width) of the image selected as the thumbnail image.

PROXY:

This displays format and other such information for proxy, if present. Displays in the CLIP PROPERTY screen.

- *1: The USER CLIP NAME recording method is selectable. For details, refer to “Selecting the USER CLIP NAME recording method” (Page 90).
- *2: ALTITUDE/LATITUDE/LONGITUDE in SHOOT are not automatically set during shooting with this unit.
These can be set in the properties of recorded clips.
- *3: Be sure to enter TEXT when entering MEMO. It is not possible to record only PERSON or OFFSET.

Checking and modifying read metadata

The camera-recorder allows you to check the details of read metadata.

- 1 Turn the POWER/MODE switch to set to PB/ THUMBNAIL mode.**
The thumbnail screen appears on the LCD monitor.
- 2 Press the MENU button to select META DATA → PROPERTY from the thumbnail menu.**

The following screen is displayed:

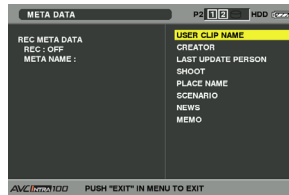

- 3 Use the Operation lever to move the pointer. Then, press the SET button on the Operation lever.**
This allows you to view the settings of the read metadata.

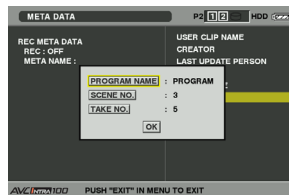

- 4 While viewing the settings for the metadata, use the Operation lever to move the pointer to the desired option. Then, press the SET button on the Operation lever.**
 - A software keyboard screen is displayed, allowing you to modify the setting.

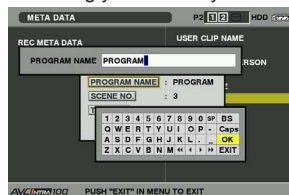

Thumbnail operations (continued)

To set whether or not the uploaded metadata is recorded

Set ON/OFF in META DATA → RECORD from the thumbnail menu. The factory setting is OFF.

Selecting the USER CLIP NAME recording method

Select META DATA → USER CLIP NAME from the thumbnail menu to select the recording method. Two options are available: TYPE1 and TYPE2.

• TYPE1 (Factory setting)

	USER CLIP NAME to be recorded
If clip metadata has been read in	Uploaded data
If no clip metadata has been read in or if the setting for recording clip metadata has been turned off	Same as GLOBAL CLIP ID (UMID data)

• TYPE2

	USER CLIP NAME to be recorded
If clip metadata has been read in	Uploaded data + COUNT value*
If no clip metadata has been read in or if the setting for recording clip metadata has been turned off	Same as CLIP NAME

* The COUNT value is indicated as a four-digit number.

The COUNT value is incremented each time a new clip is captured if clip metadata has been read in and TYPE2 has been selected as the recording method.

The COUNT value can be reset using the following procedure.

Select META DATA → PROPERTY from the thumbnail menu, then select USER CLIP NAME to display the menu shown below.

Select COUNT RESET with the Operation lever and press the SET button on the Operation lever to reset the COUNT value to 1.

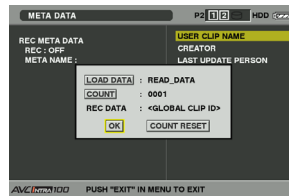

When a P2 card with a memory capacity of 8 GB or more is used in camera-recorder and a one-time continuous recording exceeds the prescribed duration (DVCPRO HD and the AVC-Intra 100: about 5 minutes; DVCPRO50 and the AVC-Intra 50: about 10 minutes; DVCPRO or for DV: about 20 minutes) or when a one-time recording extends over more than one P2 card, the recording concerned will automatically be undertaken as a separate clip. At this time, each clip will be provided with its own COUNT value.

Example of recording (DVCPRO HD) a clip on one P2 card:

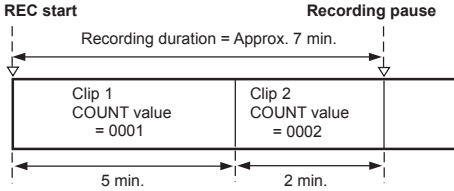

Example of recording a clip on two P2 cards:

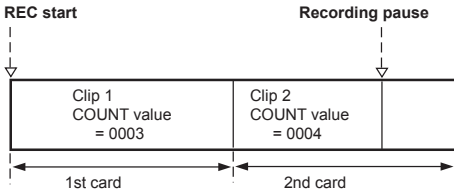

If the clip thumbnails are displayed as shown in the example above or their properties are indicated using a P2 device, the thumbnail and COUNT value of clip 1 will be displayed.

Clear the uploaded metadata

Select META DATA → INITIALIZE from the thumbnail menu, and press the SET button on the Operation lever. A YES/NO confirmation screen asks you to confirm that you want to initialize. Select YES using the Operation lever to initialize META DATA and clear the data read.

Formatting a P2 card

1 Turn the POWER/MODE switch to set to PB/ THUMBNAIL mode.

The thumbnail screen appears on the LCD monitor.

2 Press the MENU button and select OPERATION → FORMAT from the thumbnail menu.

- When the screen shown below appears, select the slot number of the P2 card you want to format and press the SET button on the Operation lever.
- Select EXIT if formatting is not required.

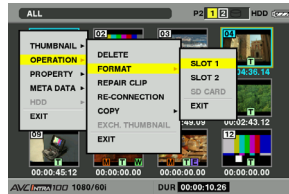

3 The following screen appears. Use the Operation lever to select YES.

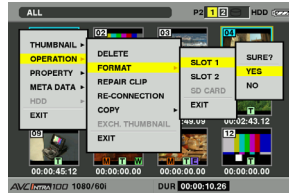

The selected P2 card is formatted.

Check that no important data remains on a card before formatting since data erased by formatting cannot be recovered.

Thumbnail operations (continued)

Formatting SD memory cards

SD memory cards can also be formatted from the thumbnail screen. With an SD memory card inserted into the camera-recorder, perform the following operation:

1 Turn the POWER/MODE switch to set to PB/ THUMBNAIL mode.

The thumbnail screen appears on the LCD monitor.

2 Press the MENU button and select OPERATION → FORMAT from the thumbnail menu.

- The following screen appears. Select SD CARD and press the SET button on the Operation lever.
- Select EXIT if formatting is not required.

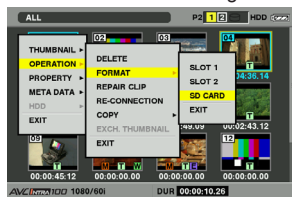

3 The following screen appears. Use the Operation lever to select YES.

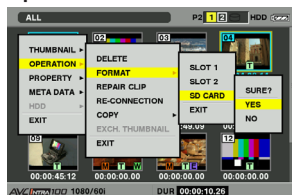

The SD memory card is formatted.

- SD memory cards can also be formatted from the menu screen. (Page 150)
- Check that no important data remains on a card before formatting since data erased by formatting cannot be recovered.

Setting the thumbnail display mode

The thumbnail display mode can be customised to suit your preferences.

1 Turn the POWER/MODE switch to set to PB/ THUMBNAIL mode.

The thumbnail screen appears on the LCD monitor.

2 Press the MENU button and select THUMBNAIL → SETUP from the thumbnail menu.

The following screen appears.

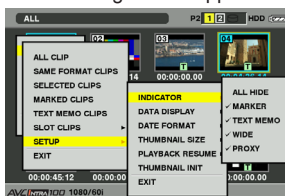

INDICATOR:

Select which indicators you want to show on thumbnails and which you want to hide.

ALL HIDE:

ON: All indicators (MARKER, TEXT MEMO, WIDE, PROXY) are not displayed.

OFF: Indication/No indication will be set depending on the following menu. The factory settings are as follows.

MARKER:

Switches the shot mark marker between indication and no indication (ON/OFF). The factory setting is ON (indication).

TEXT MEMO:

Switches the text memo marker between indication and no indication (ON/OFF). The factory setting is ON (indication).

WIDE:

Switches the wide marker between indication and no indication (ON/OFF). The factory setting is ON (indication).

PROXY:

Switches the proxy indicator between indication and no indication (ON/OFF). The factory setting is ON (indication).

DATA DISPLAY:

The time display field of the clip offers a choice of Time Code (TC), User Bits (UB), Shooting Time (TIME), Shooting Date (DATE), Shooting Time and Date (DATE TIME), clip name (CLIP NAME) or user clip name (USER CLIP NAME). The factory setting is Time Code.

DATE FORMAT:

You can specify the display order for the shooting date as either Year/Month/Day (Y-M-D), Month/Day/Year (M-D-Y) or Day/Month/Year (D-M-Y).

The factory setting is Month/Day/Year. (Only for AG-HPX250P)

The factory setting is Day/Month/Year. (Only for AG-HPX250EN)

This setting is reflected in the recording date shown in the clip property and the shooting date shown when DATE is selected under the item DATA DISPLAY.

THUMBNAIL SIZE:

For the size of thumbnails displayed on one screen, either LARGE (3 × 2 thumbnails displayed) or NORMAL (4 × 3 thumbnails displayed) can be selected. The factory default value is NORMAL.

PLAYBACK RESUME:

Selecting a position to restart playback after stopping playback on the thumbnails screen pushing the Operation lever in the ▼ direction (STOP).

ON: Playback starts from the stop position.

OFF: Playback starts from the beginning of the clip indicated by the pointer.

Note that if the pointer is moved after stopping playback, the playback will restart from the beginning of the clip indicated by the pointer regardless of this setting. Also, attempting to play back from the end of all the available clips will cause the screen to flash momentarily, indicating that there are no more clips which can be played back.

THUMBNAIL INIT:

Return the above thumbnail display settings to default. Move the cursor to this option, and press the SET button on the Operation lever. Select "YES" when the confirmation screen is displayed.

EXIT:

Returns to the previous menu.

Properties

The clip's properties and the P2 card's status are displayed.

It is possible to edit and rewrite recorded clip metadata while clip properties are displayed.

Clip property

From the thumbnail menu, select PROPERTY → CLIP PROPERTY. The following screen appears.

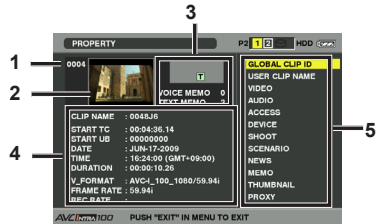

1. Clip Number

2. Thumbnail

3. Clip Information

Indicates the indicators added to the clip and the number of text and voice memos added to the clip.

The  mark appears if the clip is recorded on a writeprotected P2 card.

- **AG-HPX250P/EN is not capable of recording or playing back voice memos.**
- **Pushing the Operation lever in the ◀ ▶ direction displays the properties of the previous/next clip.**

(Continued on the next page)

Thumbnail operations (continued)

4. Clip Information

Displays detailed information about the clip.

CLIP NAME:

Display clip names.

START TC:

The time code value at the start of the recording.

START UB:

The user bit value at the start of the recording.

DATE:

The date of the recording.

TIME:

The time at the start of the recording.

DURATION:

The time length of the clip.

V_FORMAT:

The recording format for the clip.

FRAME RATE:

The frame rate for the playback.

REC RATE:

The recording frame rate is displayed. (Only displayed when using the VFR function to record in Native mode)

5. Clip Meta Data

Displays more detailed data about the clip.

Use the cursor buttons to move the pointer, and press the SET button to check the detailed content. The underlined items are automatically set during shooting.

- "Clip meta data items" (Page 88)

Modification of recorded clip metadata

- 1 Display the window for detailed clip metadata that you intend to modify in the clip properties window.
- 2 Place the cursor on the item to be modified using the Operation lever.

The metadata that can be modified are shown like [CREATOR] in the following figure.



- 3 Press the SET button on the Operation lever.

- The input window (soft keyboard) for modifying metadata is displayed.
- Use the keyboard to modify the metadata.

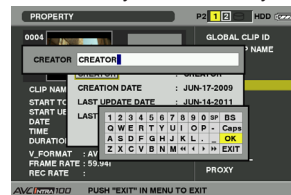

The keyboard operation is the same as "Checking and modifying read metadata" (Page 89).

- 4 Press OK on the keyboard.

The modified metadata on the clip is written and return to the metadata window.

- Deleting only the respective items of **LOCATION** (recording location data) in **SHOOT** is not possible. By setting **ALTITUDE** to empty, other **LONGITUDE/LATITUDE** items are collectively deleted.
- The metadata for a clip with the **■** incomplete clip indicator cannot be modified. For the clips recorded on multiple **P2** cards, modify the metadata while all **P2** cards are inserted.
- Any **MEMO** with 101 characters or more cannot be modified.

P2 card status display

■ P2 Card Status Display Settings

Select **PROPERTY** → **CARD STATUS** from the thumbnail menu to set the desired indication mode (remaining free space or used memory capacity) for the **P2** card status display.

1 Turn the **POWER/MODE** switch to set to **PB/THUMBNAIL** mode.

The thumbnail screen appears on the LCD monitor.

2 Press the **MENU** button and select **PROPERTY** → **PROPERTY SETUP** → **P2 CARD CAP** from the thumbnail menu.

The following screen appears. Select the **P2** card status display settings from the **P2 CARD CAP** menu option.

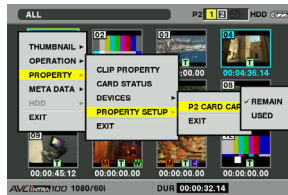

REMAIN:

Show remaining free space on the **P2** card as the **P2** card status display. (Factory setting)

USED:

Show used memory capacity on the **P2** card as the **P2** card status display.

Contents of P2 card status display settings

From the thumbnail menu, select PROPERTY → CARD STATUS. The following screen appears.

When “REMAIN” is selected:

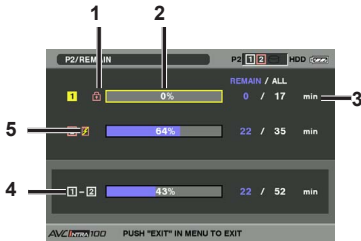

1. Write-protect Mark

The  mark appears if the P2 card is write-protected.

2. P2 Card Status (remaining free space)

The remaining memory capacity of the P2 card is indicated by a bar graph and percentage. The bar graph indicator moves to the left as the remaining free space decreases. The following indications may appear, depending on the card status:

FORMAT ERROR:

An unformatted P2 card is inserted.

NOT SUPPORTED:

An unsupported card is inserted in the camera-recorder.

NO CARD:

P2 cards are not inserted.

Push the Operation lever in the ▲ ▼ direction to place the cursor on the P2 card for data you want to access and press the SET button on the Operation lever to display detailed information about the P2 card to check individual information such as the serial number and the user ID.

3. P2 Card Remaining Capacity/Total Capacity

Displays the P2 card remaining capacity and total capacity in minutes. The total of the remaining memory capacity for each P2 card that is displayed may not match the actual total remaining memory capacity for the P2 cards because only the figure in minute is displayed. During native recording with VFR, this changes depending on the frame rate.

4. Total remaining free space for the slot

Displays the total remaining free space for all 2 slots.

Please note that the remaining capacity of a writeprotected P2 card is not included in the total remaining capacity.

When REC FUNCTION is set to LOOP, the slot total indicates the standard recording time for loop recording. However, when PROPERTY SETUP → USED is selected, the used space of the slot total is greater than that actually used, and is less than that actually used when PROPERTY SETUP → REMAIN is selected.

5. Warning symbol

When the following P2 card is detected, the  symbol is displayed.

RUN DOWN CARD:

The maximum number of overwrites on the P2 card has been exceeded.

DIR ENTRY NG CARD:

The directory structure on the P2 card is not supported.

The warning can be confirmed on the P2 card detailed information indication in “2. P2 Card Status (remaining free space)” (Page 96).

When “USED” is selected:

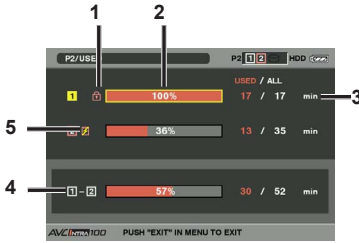

1. Write-protect Mark

The  mark appears if the P2 card is write-protected.

2. P2 Card Status (used memory capacity)

The used memory capacity of the P2 card is indicated by a bar graph and a percentage figure. The bar graph indicator moves to the right as the used memory capacity increases. The following indications may appear, depending on the card status:

FORMAT ERROR:

An unformatted P2 card is inserted.

NOT SUPPORTED:

An unsupported card is inserted in the camera-recorder.

NO CARD:

P2 cards are not inserted.

Push the Operation lever in the ▲ ▼ direction to place the cursor on the P2 card for data you want to access and press the SET button on the Operation lever to display detailed information about the P2 card to check individual information such as the serial number and the user ID.

3. P2 Card memory capacity/Total Capacity

Displays the used memory capacity on a P2 card and the total capacity, in minutes. Because fractions are truncated, the figure shown for used memory capacity on a P2 card may differ from the figure for total capacity.

The used memory capacity of a write-protected P2 card is displayed as 100%.

During native recording with VFR, this changes depending on the frame rate.

4. Total used memory capacity for all slots

Displays the total used memory capacity for all 2 slots.

Please note that the remaining capacity of a writeprotected P2 card is not included in the total remaining capacity.

When REC FUNCTION is set to LOOP, the slot total indicates the standard recording time for loop recording. However, when PROPERTY SETUP → USED is selected, the used space of the slot total is greater than that actually used, and is less than that actually used when PROPERTY SETUP → REMAIN is selected.

5. Warning symbol

When the following P2 card is detected, the  symbol is displayed.

RUN DOWN CARD:

The maximum number of overwrites on the P2 card has been exceeded.

DIR ENTRY NG CARD:

The directory structure on the P2 card is not supported.

The warning can be confirmed on the P2 card detailed information indication in “2. P2 Card Status (used memory capacity)” (Page 97).

Thumbnail operations (continued)

SD memory card status display

The status display enables a confirmation of the SD memory card formatted condition, available memory capacity etc.

From the thumbnail menu, select PROPERTY → DEVICES → SD CARD.

SD STANDARD:

Indicates that an SD memory card is formatted according to the SD/SDHC standard.

SUPPORTED:

Complies with SD/SDHC

NOT SUPPORTED:

Does not comply with SD/SDHC

USED:

Used capacity (bytes)

BLANK:

Free space (bytes)

TOTAL:

Total capacity (bytes)

NUMBER OF CLIP:

The number of clips on an SD memory card when clips have been copied to an SD memory card.

PROTECT:

Write protected

Useful playback functions

Variable speed search

This function enables you to change the playback speed and search for specific scenes.

- 1 Press the Operation lever in the ► direction (playback) during playback. On the remote control, press the VAR. SEARCH button.



Camera-recorder or Remote control

[1x] appears on the screen and the media is played back at the normal speed.

- 2 Press the PAGE/AUDIO MON/VAR button to change the playback speed.

- The possible speeds are pause, 1/5x, 1x, 2x, 4x, 12x, and 24x in forward/reverse. The current speed is incrementally increased with the + button and decreased with the – button.
- Change the speed with the [▲] and [▼] MENU buttons on the remote control.
- Audio is not played back at speeds of 12x and 24x.

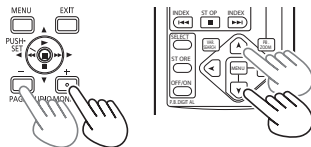

Camera-recorder or Remote control

To return to normal playback, push the Operation lever in the ▲ direction (► playback) or press the VAR.SEARCH button on the remote control.

Slow playback

During play, press one of the STILL ADV (◀◀ or ▶▶) buttons on the remote control.

To return to normal playback, press PLAY (►).

Fast forward/rewind playback

During playback, push the Operation lever in the ◀◀ (rewind) or ▶▶ (fast-forward) direction.

This performs fast forward/rewind playback at 4x speed.

When this button is held down, the playback speed becomes faster (32x speed).



Camera-recorder or Remote control

On the remote control, press REW (◀◀) or FF (▶▶).

To return to normal playback, push the Operation lever in the ► direction (playback) or press PLAY (►) on the remote control.

Frame-by-frame playback

- 1 Press II (pause) during playback to set the unit to the pause mode.

- 2 Press the PAGE/AUDIO MON/VAR button to play frame-by-frame.

On the remote control, press the STILL ADV (◀◀ or ▶▶) button.

- Press and hold the button to perform frame-by-frame play continuously.

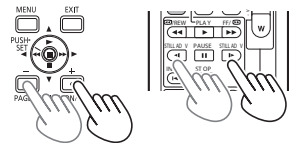

Camera-recorder or Remote control

Useful playback functions (continued)

Clip skip

- 1 Press **II** (pause) during playback to set the unit to the pause mode.
- 2 Push the Operation lever in the **◀◀** (rewind) or **▶▶** (fast-forward) direction.

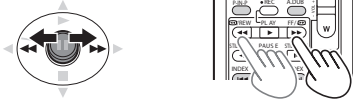

Camera-recorder or Remote control

On the remote control, press **REW** (◀◀) or **FF** (▶▶).

Setting **SEEK SELECT** on the setting menu **OTHER FUNCTIONS** screen to **CLIP&T** allows you to cue the start of the clip and the position a text memo is attached in sequence. (Page 152)

Adjusting the volume

With the **PAGE/AUDIO MON/VAR** button, adjust the volume of the sound that is output from the internal speaker and headphone jack.

On the remote control, press the **ZOOM/VOL** button.

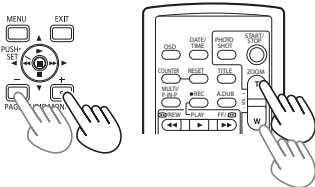

Camera-recorder or Remote control

Viewing images on a TV/monitor

You can view the images on a TV/monitor if you connect the unit to a monitor using a BNC cable (not included), an AV cable (not included), or an HDMI cable (not included).

- 1 **Connect the camera-recorder to the TV set/monitor.** (Page 104)
- 2 **Start playback.**

- To display the information shown in the viewfinder or on the LCD monitor on a TV set/monitor connected with an AV cable, press the **OSD** button on the remote control. Press the **OSD** button again to clear the display. However, information displayed on video that is output from **SDI OUT** and **HDMI OUT** is set with **SDI & HDMI CHAR** on the setting menu **OUTPUT SEL** screen, not the **OSD** button.

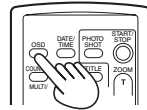

Checking the date and time

Press the **DATE/TIME** button on the remote control to show the date and time of shooting on the screen. The display changes as follows each time you press the button.

Time
↓
Date
↓
Time and Date
↓
No display

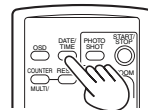

Connecting external units

Headphones

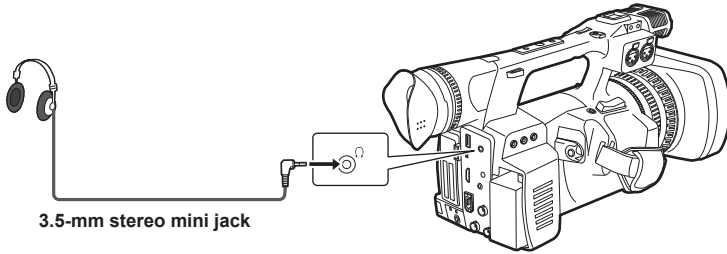

- Sound is no longer heard from the speaker when the headphones are connected.

External microphone

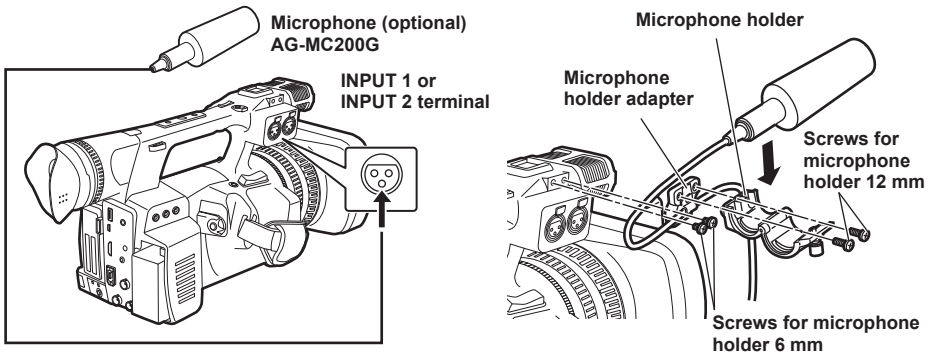

- When attaching an external microphone to the microphone shoe, use the supplied microphone holder and microphone holder adapter.
- When attaching the microphone holder and the microphone holder adapter, be sure to tighten the screws firmly even though you might hear a squeaking sound.
- Use the cable clamber of the microphone holder adapter to fix the microphone cable.

Connecting external units (continued)

Personal computer (non-linear editing/file transfer)

File transfer/nonlinear editing

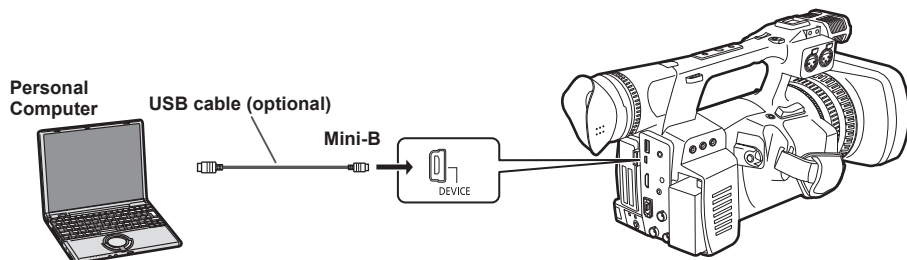

- "Procedures for making connections to a personal computer" (Page 109)
- USB2.0 cable is not included with this camera. Please use a commercial USB2.0 cable (double-shielded for noise reduction).

Hard disk drive (data copying)

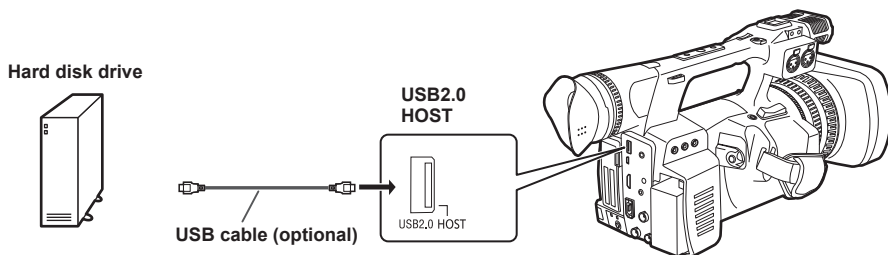

- "Switching to the USB HOST mode" (Page 111)
- USB2.0 cable is not included with this camera. Please use a commercial USB2.0 cable (double-shielded for noise reduction).

Digital video equipment (Dubbing)

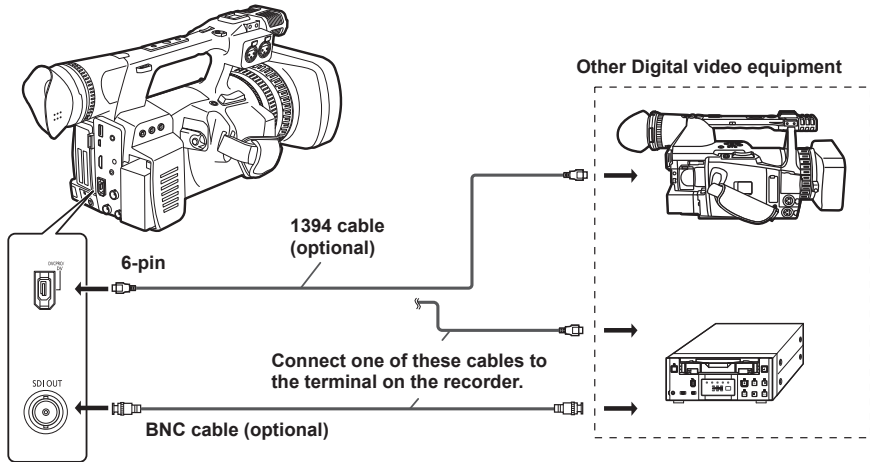

- "Control of external devices through 1394 connection" (Page 106)
- "Recording signals input to the DVCPRO/DV connector" (Page 105)
- Please use a double-shielded IEEE1394 cable.

AUTO REC function

When recording is started or stopped on this camera-recorder, recording start/stop information can be output through the SDI (HD) connector to control external device.

* The external device should support this function.

Connecting external units (continued)

TV/Monitor (playback/dubbing)

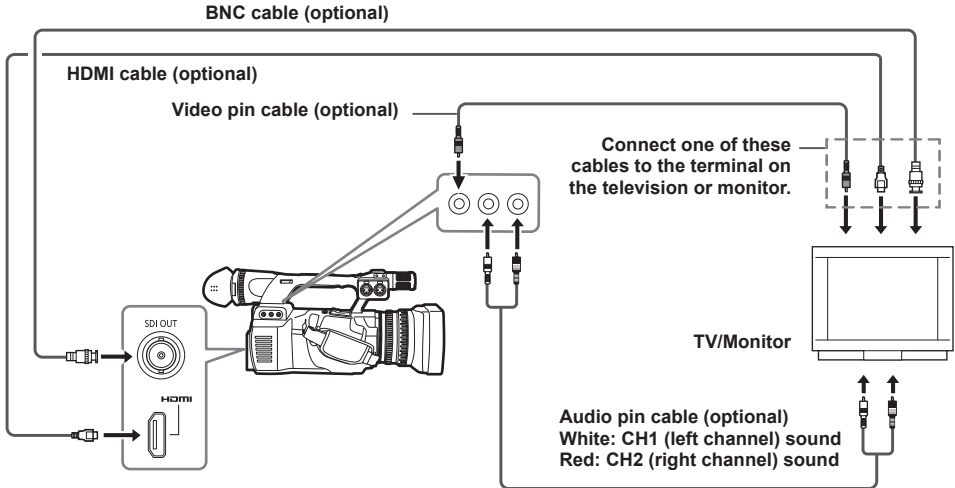

- VIERA Link is not supported. Please be aware that when using an HDMI cable and connecting this camera to a device that supports VIERA Link, the VIERA Link of other devices may not work in some cases.
- From the HDMI OUT terminal, SD signals (480i, 576i) are converted to progressive signals (480P, 576P) then output.
- Simultaneous display with the LCD monitor and the viewfinder is not possible when outputting video from the SDI OUT terminal.
For simultaneous display, set SDI OUT on the setting menu OUTPUT SEL screen to OFF and EVF MODE on the DISPLAY SETUP screen to ON.
- Please use a double-shielded SDI cable (optional).
- Please use a double-shielded HDMI cable (optional).
- It is recommended that you use a Panasonic HDMI cable.

Connections to the DVCPRO/DV connector

Recording signals input to the DVCPRO/DV connector

1 Connect a 1394 cable (DV cable).

- “Precautions in 1394 connections” (Page 107)
- Make sure that the signal format of the camera-recorder and the connected device is the same.

2 To route inputs via the IEEE1394 interface, set the menu option REC SIGNAL in the SYSTEM SETUP screen to 1394.

- To use HD (1080i, 720P) set the menu option REC FORMAT in the SYSTEM SETUP screen to DVCPRO HD/60i (DVCPRO HD/50i) or DVCPRO HD/60P (DVCPRO HD/50P).
The AVC-Intra format and DVCPRO HD native recording do not allow input via the IEEE1394 interface.

3 Check that video from the IEEE 1394 interface is displayed in the viewfinder or LCD monitor, and press the START/STOP button to begin recording.

4 Press the START/STOP button again to stop recording.

- Signals that have the same format as that set in the menu options SYSTEM MODE and REC FORMAT in the SYSTEM SETUP screen should be input to the IEEE1394 interface. A signal in a different format will not be correctly recorded on a P2 card. Video and audio recording and EE type video and audio of signal inputs other than 1x speed playback signals may not work.
 - “Errors and warnings” (Page 126)
- Audio signal inputs are input signals from the DVCPRO/DV connector.
- 32 kHz/4CH (12 bit) audio signals input via the IEEE1394 interface are recorded as 48 kHz/4CH (16 bit) on a P2 card.
- It is not possible to use the GENLOCK IN connector to synchronize to an external reference signal.
- Signals output from the VIDEO OUT or AUDIO OUT connectors differ from actual input signals. Use such signals for monitoring.
- The following functions do not operate.
 - Pre-recording function
 - Loop recording function
 - Interval recording and one-shot recording function
 - One-clip recording function
- As well as those displayed in blue, there are other items on the setting menu for which the setting value cannot be changed. However, this is not a fault and these items are not related to this function.

Time Code and User Bits

- When input from the IEEE1394 interface is selected, the time code and user's bit input from TC IN/OUT cannot be recorded on P2 card.
- When input from the IEEE1394 interface is selected, the time code output from TC IN/OUT is not synchronized with the video signal output from the VIDEO OUT terminal.

Subcode area time codes and user bits

- When input from the IEEE1394 interface is selected and the time code is set to free run, the subcode area time code input from the DVCPRO/DV terminal can be recorded on P2 card.
- To record user bits input from the DVCPRO/DV connector on a P2 card, set the menu option UB MODE in RECORDING SETUP to EXT.

VAUX area time codes and user bits

When input from the IEEE1394 interface is selected, time code and user bits of the VAUX area input from the DVCPRO/DV connector is recorded on a P2 card regardless of camera-recorder menu settings and switch positions.

Recording UMID (Unique Material Identifier) data

When input from the IEEE1394 interface is selected, UMID data input via the DVCPRO/DV connector is recorded on a P2 card. When no UMID data is available, the camera-recorder generates and records such data. UMID data is not recorded when the camera-recorder is operating in the DV mode.

Control of external devices through 1394 connection

Connecting an external device for backup recording to the DVCPRO/DV connector allows the operator to control start and stop recording from the camera-recorder.

- 1 Connect a 1394 cable (DV cable).**
 - "Precautions in 1394 connections" (Page 107)
 - Set 1394 CONTROL in the setting menu OTHER FUNCTIONS screen to BOTH.
- 2 Use the setting menu 1394 CMD SEL (OTHER FUNCTIONS) to select the command for terminating recording that external devices receive.**
 - For details on menu operation, refer to "Using the setup menus" (Page 28 of Vol. 1).
- 3 Recording can be started and stopped for both this unit and external devices by pressing the START/STOP button on this unit.**

Note the following when backup recording.

- Menu settings are retained even if you turn the power off. So if you use the camera-recorder with the settings for backup recording still in effect, images on media in any unit that connected may be overwritten. After backup recording, check the menu item settings before you operate the camera-recorder.
 - If you use another AG-HPX250P/EN as the external unit for backup recording, select "OFF" for 1394 CONTROL on the external unit and set REC SIGNAL to "1394" on the setting menu SYSTEM SETUP screen.
 - Backup recording may not work properly if you connect two or more external units.
 - Use a 1394 cable of 4.5 m or less for connection.
 - Set the external unit up to receive 1394 signals before backup recording.
 - You can have a media in the external unit start recording automatically when the media in this unit is almost finished. Set 1394 CONTROL on the setting menu OTHER FUNCTIONS screen (Page 151) to "CHAIN".
 - Note that images are recorded even when you perform a rec check.
-

- External devices cannot be controlled via 1394 connection when AVC-Intra format or DVCPRO HD native recording is selected.
- Backup recording does not work in three of the special recording modes: Interval recording, One-shot recording and Loop recording. (Page 44 – 46)
- Please note that when performing backup recording to a connected external device with the time code of this unit set to REC RUN, continuing recording when there is no more free space on the P2 card inserted into this unit causes the time code output from the DVCPRO/DV terminal to halt.
- Backup recording may not be performed by external devices if you perform recording start → stop → recording start in quick succession.

Precautions in 1394 connections

- The camera-recorder does not supply power via the cable.
- Observe the following in connections using a 1394 cable.
 - Connect this unit to only one other device.
 - Do not expose the DVCPRO/DV connector to excessive force when connecting a 1394 cable to avoid damaging the connector.
 - If an error (1394 INITIAL ERROR) should occur when making a connection, reinsert the 1394 cable or turn the camera-recorder off and then turn it back on again.
 - Make sure that the camera-recorder and all connected devices are connected to ground (or connected to a common ground). If the equipment cannot be connected to ground, turn off all connected devices before connecting or disconnecting an IEEE1394 cable.
 - When connecting the unit to a device with a 4-pin connector, connect the cable to the 6-pin connector on the camera-recorder first.
- Be sure to properly connect the 1394 cable to the DVCPRO/DV connector on a computer with a 6-pin connector. Note that inserting the plug the wrong way round may damage the connector.

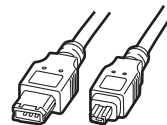

6-pin type 4-pin type

- AV signals may be disrupted when connected devices are turned on and off or when the interface cable is connected or disconnected.
- It may take the system a few seconds to stabilize after switching input signals or changing modes. Start recording after the system has stabilized.
- The AUDIO LEVEL control does not work in recordings that involve IEEE1394 interface input or output signals.

Connections to the DVCPRO/DV connector (continued)

- Observe the following precautions when controlling a P2 memory card camera-recorder using PC application software (editing software).
 - Recording cannot be inserted to a portion within a clip. It can only be appended to the end of the newest clip.
 - Do not open the thumbnail screen during application software operation as this may prevent normal software operation.
- Unprocessed video and audio signals are output via the IEEE1394 interface during special playback. When monitored on another device, these video and audio signals may sound different than when played back on this unit.
- A DV or DVCPRO output format makes it possible to select audio channel CH1/CH2 or CH3/CH4 output from the IEEE1394 interface in the menu option 1394 AUDIO OUT in the AUDIO SETUP screen.
- When recording a signal from an external device, do not halt output at the external device or disconnect the cable as the device may not be recognized when recording is recommenced.
- When recording a signal from an external device, do not change the output format used by the external device as recording cannot be correctly performed.
- The automatic recording function on DVD devices may not function correctly. In such cases, please record manually.

Nonlinear editing with P2 card (PC mode: USB device)

A USB 2.0 connection to a computer or other device allows you to use P2 cards in the camera-recorder as mass storage.

Procedures for making connections to a personal computer

1 Connect a USB cable to the USB 2.0 connector.

A USB 2.0 cable is not supplied with the AG-HPX250P/EN. Use a commercially available USB cable (with shielding or other noise-reduction measures) that supports USB 2.0. (Page 102)

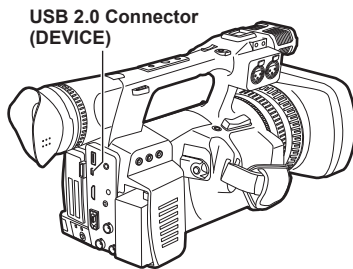

2 Select USB Device in PC MODE SELECT on the setting menu SYSTEM SETUP screen, and press SET on the Operation lever.

- Refer to the section "Using the setup menus" (Page 28 of Vol. 1) for menu operation.

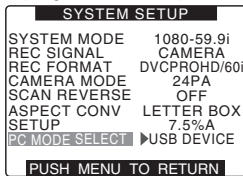

3 Press MENU twice to exit the menus.



4 Turn the POWER/MODE switch to the MODE position to illuminate the PB/THUMBNAIL lamp, and then turn and hold it.

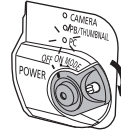

- The PC lamp illuminates, the camera enters PC mode, and video/audio output stops.
- You cannot switch to PC mode directly from CAMERA mode. Leaves the thumbnail screen of PB/THUMBNAIL mode.

To make a USB connection, you must first install the P2 software on the supplied CD-ROM on the computer. Select the "AG-HPX250" driver. This USB driver supports only the Windows operating system. For details, refer to the installation manual.

- A USB driver must be installed on the computer.
- Use a computer that supports USB 2.0 since the camera-recorder supports only USB 2.0.
- Connect only one camera-recorder to a personal computer via USB.
- Do not remove P2 cards when the camera-recorder is connect to a personal computer via USB.
- In a USB connection, the P2 CARD ACCESS LED is on only when the card is accessed.
- In USB device operation, recording, playback and clip thumbnail operations are not available.
- The free space and status of P2 cards is not displayed when operating as a USB device, and video/audio cannot be output or displayed.

(Continued on the next page)

Nonlinear editing with P2 card (PC mode: USB device) (continued)

- When a USB connection is present the PC operation lamp illuminates, and “USB DEVICE CONNECT” appears in the center of the viewfinder or LCD monitor. When connection is not correctly, “DISCONNECT” appears in the viewfinder.
- In USB device mode, clips on P2 cards can be displayed but video from the camera-recorder or an external device cannot be recorded.

Mode lamp (PC)



POWER/MODE switch

(Viewfinder display)



5 Terminating USB device mode.

- Set the camera-recorder POWER/MODE switch to OFF.
- You cannot return to CAMERA mode or PB/THUMBAIL mode from USB device mode.

Using a hard disk drive (PC mode: USB host)

In this mode, it is possible to connect to a hard disk drive (HDD), store card data (EXPORT): Refer to "Writing data on a hard disk drive" (Page 115), view thumbnails of stored clips (EXPLORE): Refer to "Viewing hard disk drive information" (Page 112), and write data back to P2 cards (IMPORT): Refer to "Writing data back to P2 cards" (Page 116).

Switching to the USB HOST mode

- 1 Select **USB HOST** in **PC MODE SELECT** on the setting menu **SYSTEM SETUP** screen, and press **SET** on the Operation lever.
 - Refer to the section "Using the setup menus" (Page 28 of Vol. 1) for menu operation.

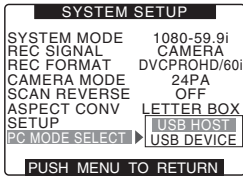

- 2 Press **MENU** twice to exit the menus.



- 3 Turn the **POWER/MODE** switch to the **MODE** position to illuminate the **PB/THUMBNAIL** lamp, and then turn and hold it.

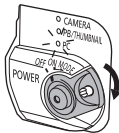

- The PC lamp illuminates, the camera enters PC mode, and it goes to the thumbnail screen.
- When a hard disk drive is connected, the HDD indication in the upper right corner stays illuminated. However, if this indicator illuminates red, it means that the hard disk drive is not in a usable state. Confirm the HDD type/state.



USB HOST display

- In **USB HOST** mode, clips on P2 cards can be displayed but video from the camera-recorder or an external device cannot be recorded. Clips written to a hard disk must be written back to a P2 card before it can be played back.
 - "Writing data back to P2 cards" (Page 116)
- You cannot return to standard mode from **USB HOST** mode. Turn the power off and then turn it back on again.

Using a hard disk drive (PC mode: USB host) (continued)

Using the USB HOST mode

Usable hard disk drives

- Hard disk drives connectable via USB 2.0
- The units compatible with the storage unit that has Panasonic USB I/F
Refer to the support site at the following Website for the compatible units.

<http://pro-av.panasonic.net/>

- While the USB HOST mode supports USB bus power (5 V, 0.5 A), some hard disk drives may not activate. If this is the case, power must be supplied in a different way.
- Do not connect more than one drive even through a hub or any other device. Even with devices other than a hard disk drive, do not connect to the drive together with the hard disk drive through a hub.
- The unit does not support a hard disk drive of 2 TB (2048 GB) or more.
- To prevent copying or formatting problems from occurring during connection to a hard disk drive, be sure that the camera's battery is sufficiently charged or use the AC adaptor.
- Versions 2.** and later of the P2 STORE (AJ-PC060G) support USB host mode for this unit.
Versions 1.** cannot connect. Please upgrade.

Viewing hard disk drive information

You can view the information on the hard disk drive connected via USB with the following steps.

- 1 **Switch the mode to USB HOST.**
 - "Switching to the USB HOST mode" (Page 111)
 - The thumbnail screen is displayed.
(USB HOST is displayed in the bottom right.)
- 2 **Connect the hard disk drive to the camera-recorder via USB 2.0.**
- 3 **Press the MENU button and select HDD → EXPLORE from the thumbnail menu.**
The screen provides the information about the hard disk drive.

For Type S or P2 STORE

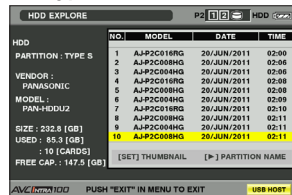

Press the EXIT button. ↑ Press the SET button.



For the FAT

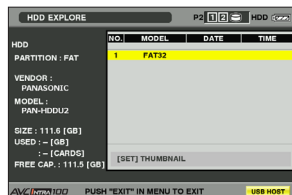

Press the EXIT button. ↑ Press the SET button.



1. PARTITION

This section indicates the type of the hard disk drive.

The available functions depend on the type of hard disk drive.

HDD type	Feature	Available functions
TYPE S	A special format that allows high-speed writing and writing back on a card-by-card basis. A drive formatted with the camera-recorder uses this format.	Thumbnail viewing, writing and writing back on a card basis, writing back on a clip basis, and formatting
P2 STORE	P2 STORE (AJ-PCS060G). No writing can be performed.	Thumbnail viewing, writing back on a card basis, and writing back on a clip basis
FAT	For a hard disk drive with the first primary partition formatted in FAT 16 or 32, as seen on personal computers, etc., which requires a CONTENTS directory at its root.	Thumbnail viewing, reading on a clip basis, and formatting * Once formatted, the hard disk drive can be treated as a TYPE-S HDD.
OTHER	Hard disk drives not described above. * They are hard disk drives that have no CONTENTS directory or use the NTFS and any other file system instead of FAT 16 or 32.	Formatting * Once formatted, they can be treated as a TYPE-S HDD.

2. VENDOR

This section indicates the vendor for the hard disk drive.

3. MODEL

This section indicates the model of the hard disk drive.

4. SIZE

This section indicates the total storage on the hard disk drive.

5. USED

This section indicates the used space on the hard disk drive (in GB) and the number of P2 cards in use.

6. FREE CAP.

This section indicates the remaining free space on the hard disk drive in GB.

7. PARTITION

This section indicates the partition number (one P2 card is used as a unit) on the hard disk drive.

The screen can show up to 10 partitions. If there are more than 10 partitions, push the Operation lever in the ▼ direction and scroll down to display the remaining partitions.

8. MODEL

This section indicates the model of the P2 card that originally contained data on the partition.

You can switch to PARTITION NAME by pushing the Operation lever in the ► direction. Push the Operation lever in the ◀ direction to return to the original model name display.

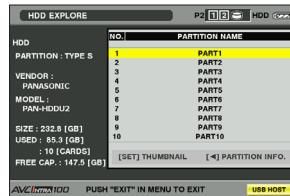

9. DATE/TIME

This section indicates the date and time the data on the partition was recorded.

10. SERIAL

This section indicates the serial number of the P2 card that originally contained the data on the partition.

(Continued on the next page)

11. VERIFY

This section indicates the verification setting and results at the time the data on the partition was recorded.

ON:FINISHED :

Verification was performed and the results agreed.

ON:FAILED :

Verification was performed and the results did not agree.

OFF :

No verification was performed.

- - - :

No verification information is available.

- Even for a FAT-type hard disk drive, the 1001st or later clips are not shown.
- For a FAT-formatted hard disk drive, the information about only the first partition is shown.
- For a P2 STORE (AJ-PCS060G) that has an invalid partition, that partition information is shown in gray.

12. NAME

This section indicates the PARTITION NAME. Enter the PARTITION NAME from the software keyboard by selecting [CHANGE PARTITION NAME] in the OPERATION MENU while the thumbnail of the hard disk drive is displayed. (Max. 20 characters)

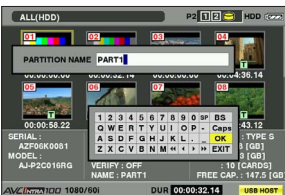

Formatting a hard disk drive

- 1 **Switch the mode to USB HOST.**
 - "Switching to the USB HOST mode" (Page 111)
 - The thumbnail screen is displayed. (USB HOST is displayed in the bottom right.)

- 2 **Connect the hard disk drive via USB.**

- 3 **Press the MENU button and select HDD → EXPLORE from the thumbnail menu.**

The display provides a screen that shows the information about the hard disk drive.

- 4 **From the thumbnail menu, select OPERATION → FORMAT (HDD) and select YES using the Operation lever. Then, the confirmation message is displayed again. Select YES.**

The camera-recorder starts formatting the hard disk drive. Once formatted, the hard disk drive can be treated as a TYPE-S HDD.

- Formatting a hard disk drive erases all contents of it. Note that you cannot erase the contents of certain partitions by specifying them.
- Operation of the hard disk drive with this unit, and the data in the hard disk drive are not guaranteed if a hard disk drive formatted by this unit is rewritten using another PC or similar.
- Data erased by formatting cannot be restored, so be sure to perform the format after first confirming the data.

Writing data on a hard disk drive

1 Switch the mode to USB HOST.

- “Switching to the USB HOST mode” (Page 111)
- The thumbnail screen is displayed.
(USB HOST is displayed in the bottom right.)

2 Connect a hard disk drive via USB.

A hard disk drive that has not been formatted with the camera-recorder must be formatted as directed in “Formatting a hard disk drive” (Page 114).

3 Insert a P2 card.

4 Press the MENU button and select HDD → EXPORT from the thumbnail menu.

Specify the slot that contains the P2 card bearing the data to be written to the hard disk drive.

5 Select YES.

- This starts the write process.
- When the data is being written, a progress bar is displayed. To discontinue writing, press the SET button on the Operation lever instead of cancellation confirmation.
- When the writing is completed, the message “COPY COMPLETED!” is displayed.

-
-
- **To disable verification at the time of writing, select HDD → SETUP from the thumbnail menu and set the option VERIFY to OFF. This speeds up writing without verifying data writing.**
 - **Select ALL SLOT to write data collectively onto all P2 cards currently inserted in the unit to the hard disk drive.**
-
-

- **For a Type-S hard disk drive, data can be written on a card basis. The data on up to 23 P2 cards can be stored on the hard disk drive. The data set on each P2 card is recognized as a separate drive by the PC.**
 - **If data on a P2 card that contains a defective clip must be written to a hard disk drive, then we recommend fixing or deleting that clip before writing the data.**
 - **When the process is discontinued during verification, the data on the P2 card has been written to the hard disk drive.**
-
-

Writing data back to P2 cards

Selecting clips on the hard disk drive

You can select clips on the hard disk drive to be written back to P2 cards.

- 1 Switch the mode to USB HOST.**
 - “Switching to the USB HOST mode” (Page 111)
 - The thumbnail screen is displayed.
(USB HOST is displayed in the bottom right.)
- 2 Connect a hard disk drive via USB.**
- 3 Insert the target P2 card in a slot.**
- 4 Press the MENU button and select HDD → EXPLORE from the thumbnail menu. Move to the appropriate partition and select it with the SET button on the Operation lever.**
- 5 From among the thumbnails, select the clips to be written to the P2 card.**
- 6 Press the MENU button and select OPERATION → COPY. Then, specify the slot that contains the target P2 card.**
- 7 Select YES.**
 - This starts the data write to the P2 card.
 - When the writing is completed, the message “COPY COMPLETED!” is displayed.

-
- **When only selected files are written, no verification is performed.**
 - **Copy data in clip units from cards with a different model number as data cannot be imported by the partition between such cards. Copy data by clip.**
-

Selecting clips from the thumbnail menu

For a Type-S or P2 STORE hard disk drive, you can write data back to a P2 card with the same model number on a card basis. The target P2 cards must be preformatted.

- 1 Switch the mode to USB HOST.**
 - “Switching to the USB HOST mode” (Page 111)
 - The thumbnail screen is displayed.
(USB HOST is displayed in the bottom right.)
- 2 Connect a hard disk drive via USB.**
- 3 Insert the target P2 cards in slots.**
- 4 Press the MENU button and select HDD → EXPLORE from the thumbnail menu. Move to the appropriate partition and select it with the SET button on the Operation lever.**
- 5 From the thumbnail menu, select OPERATION → IMPORT. Then, specify the slots that contain the empty target P2 cards.**
- 6 Select YES.**
 - This starts the write process.
 - When the writing is completed, the message “COPY COMPLETED!” is displayed.

<For your information>

To disable verification during writing, select HDD → SETUP from the thumbnail menu and set the option VERIFY to OFF. This speeds up writing without verifying data writing.

-
- **If a clip is written back to a P2 card different from the original card that contained that clip, then the clip may be incomplete. If this is the case, reconnect the clip.**
 - “Reconnection of incomplete clips” (Page 85)
 - **Copy data in clip units from cards with a different model number as data cannot be imported by the partition between such cards. Copy data by clip.**
-

Direction for using a hard disk drive

- A hard disk drive (including the P2 STORE (AJ-PCS060G)) must be used under the following conditions:
 - It must meet the operating requirements (e.g. temperature).
 - It must not be placed in an instable place or a place exposed to vibrations.
- Some hard disk drives and cables do not operate properly.
- Some hard disk drives with the SATA (Serial ATA) interface or the PATA (Parallel ATA) interface connected by a USB conversion cable may not be recognized.
- When copying data, a hard disk drive must have sufficient free space.
- Please be aware that removing the cable or destination P2 card during format or copy, or turning off the power of this camera or hard disk drive can cause corruption of data and faults on the P2 card and camera. Furthermore, ensure that the unit is fully charged, or use an external DC power source.
- Since hard disk drives are high precision devices, there is a high possibility that they may become incapable of writing data depending on the conditions of use.
- **Take note that we will not be liable for loss of data caused by failed hard disk drives or any other problem as well as direct or indirect damages resulting from the loss of data.**
- We do not guarantee that hard disk drives will operate properly with the camera-recorder or that the data on them will be properly retained if data copied to them from the camera-recorder has been replaced with other data using a PC.
- By using the drive mount converter distributed on the following URL, the hard disk drive can be mounted in the designated folder when connected.

<http://pro-av.panasonic.net/>

Warning and error display for thumbnail operation and USB HOST MODE

■ Thumbnails

Message

Description/Measure

CANNOT ACCESS!

Data cannot be accessed because it is corrupted or for other reasons.
Restore media and clips to normal state before access.

CANNOT CHANGE!

With the AVC-Intra100 or AVC-Intra50, clips for which thumbnails cannot be created, and for which the  mark is displayed cannot have the thumbnail for their text memo position changed.
Please set the SYSTEM MODE item to match the clip. The menu item SYSTEM MODE is found on the setting menu SYSTEM SETUP screen. (Page 135)

CANNOT COPY!

Images cannot be copied.
Check the conditions for copying.

CANNOT DELETE!

Contents version mismatch prevents deletion.
Match devices and contents version.

CANNOT FORMAT!

P2 card problem prevents formatting.
Check P2 card.

CANNOT RECONNECT!

A clip that does not span multiple cannot be reconnected.
Check selected content.

CANNOT REPAIR!

Data cannot be repaired since content that cannot be repaired is selected.
Check selected content.

LACK OF CAPACITY!

There is not enough recording capacity left on the card.
Insert a card with sufficient recording capacity.

Using a hard disk drive (PC mode: USB host) (continued)

MISSING CLIP!

A shot mark will be added to the clips recorded on multiple P2 cards when all P2 cards are not inserted yet.

Insert all P2 cards with recorded clips, and confirm that the  incomplete clip indicators disappear, and then add shot marks.

NO CARD!

No P2 or SD card is inserted.
Insert compatible media.

NO COPY TO SAME CARD!

A clip cannot be copied to the card storing the original clip.
Copy the selected clip to a card that does not contain the original clip.

NO FILE!

The designated file is not found.
Check the file.

SAME CLIP IS SELECTED!

Images cannot be copied since the clip has already been copied from the original clip.
Confirm the selected clip and release either the source clip or the destination clip and then execute the copy operation.

TOO MANY CLIPS!

The number of clips on the copy target card exceeds 1000.
Reduce the number of selected clips.

UNKNOWN CONTENTS FORMAT!

Warning displayed to indicate contents version mismatch.
Match devices and contents version.

UNKNOWN DATA!

The metadata character code is invalid.
Use UTF-8 for the metadata character code.
Use the viewer to enter correct characters.

USER CLIP NAME MODIFIED!

Characters in the clip name had to be deleted in adding the counter value.
The user clip name plus the counter value can only contain up to 100 bytes. Characters in the clip name are automatically deleted when the total exceeds 100 bytes.

WRITE PROTECTED!

The P2 or SD card is write protected.
Insert write-enabled media.

■ Soft keyboard

Message

Description/Measure

CANNOT CHANGE!

[PERSON] will be entered while the text memo is not available.
Enter [TEXT] before entering [PERSON].

CANNOT SET!

INVALID VALUE!

The entered value is incorrect.
Change the value.

■ HDD (USB HOST MODE)

Message

Description/Measure

CANNOT ACCESS CARD!

An error occurred during P2 card access.
Check P2 card.

CANNOT ACCESS TARGET!

An error occurred during hard disk access.
Check hard disk status and connection.

CANNOT FORMAT!

The hard disk cannot be initialized.
Connect another hard disk drive.

CANNOT RECOGNIZE HDD!

The destination target cannot be properly recognized.
Reboot the hard disk or connect a different hard disk.

CARD IS EMPTY!

CANNOT COPY!

The P2 selected for copying is empty.
Copying is not performed since the card is empty.

FORMAT P2 CARD!

This warning indicates that data could not be imported from a hard disk to a P2 card because the P2 card contained recorded data. You cannot copy to a P2 card that contains data.
Format the card on a P2 device and copy again.

LACK OF CAPACITY!

Not enough space left on the hard disk.
There is not enough space on the connected hard disk. Use a new hard disk or formatted hard disk.

HDD DISCONNECTED!

The unit is not connected to a hard disk.
Reconnect the USB cable. If the hard disk does not operate normally, turn it off and turn it back on again.

MISMATCH COMPONENT!

Copying is not possible since the model number of the destination card does not match that of the source card.
Use a P2 card with the same model number or copy video in clip units.

TOO MANY PARTITIONS!

There are too many partitions.
Hard disks can handle up to 23 partitions. Use a new hard disk or formatted hard disk.

TOO MANY TARGETS!

Multiple devices are connected.
Disconnect devices, turn off the unit and turn it back on again.

UNKNOWN DEVICE CONNECTED!

The connected DVD drive is not compatible.
Disconnect devices, turn off the unit and turn it back on again.

VERIFICATION FAILED!

The compare check after copying failed.
Copy the data again.

- For details on the error display of "Screen displays", see "Errors and warnings" (Page 126).

Screen displays

Viewfinder screen status displays

In addition to video, the viewfinder or LCD monitor shows messages indicating camera-recorder settings and operating status, center markers, safety zone markers, zebra patterns and other indications.

Viewfinder status indication layout

The illustration below shows the indications (except MODE CHECK) that are displayed in the viewfinder.

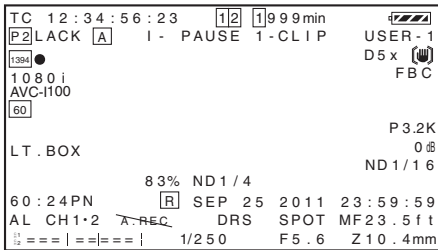

Selecting viewfinder display information

To select items in the viewfinder screen, open the DISPLAY SETUP screen and turn on or off each item or type.

- For details on menu operation, refer to "Using the setup menus" (Page 28 of Vol. 1).

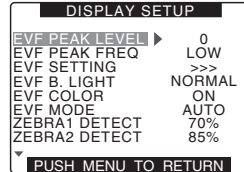

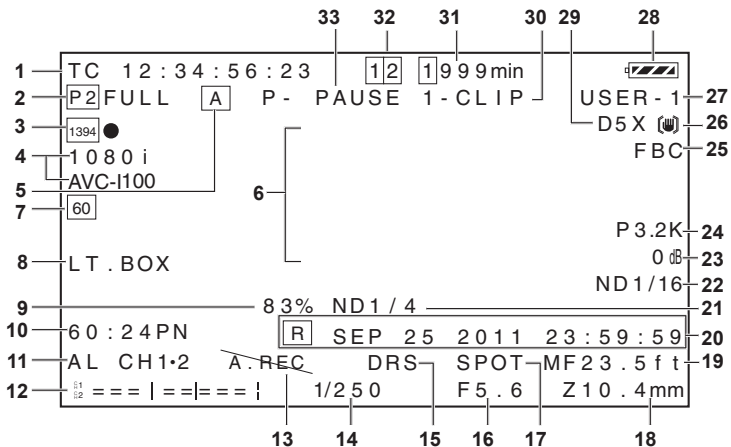

1 Time code displays

Each press of the COUNTER button displays (or turns off) the indications listed below.

(No indication)

Counter:

Counter value (during recording only)

CLIP:

Clip Counter value (during recording only)

Clip Counter value during each shooting session.

CLIP is indicated when set REC COUNTER on the setting menu DISPLAY SETUP screen to CLIP.

TC:

Time code value

TC* is indicated when the time code value cannot be correctly read from DVCPRO/DV connector input.

The colon between the seconds and the frames changes to a period (.) in drop frame mode.

tc:

Time code value (frame digits are indicated in 24 frames)

tc* is indicated when the time code value cannot be correctly read from DVCPRO/DV connector input.

The colon between the seconds and the frames changes to a period (.) in drop frame mode.

UB:

User bit values

UB* is indicated when the user bit value cannot be correctly read from DVCPRO/DV connector input.

FR:

Frame rate information for recording

FR60I -: 60i interlace mode (60 fields/s)

FR60P -: 60P progressive mode (60 fields/s)

FR30P -: 30P progressive mode (30 fields/s)

FR24P *: 24P progressive mode (24 fields/s)

FR24PA *: 24P advanced mode (24 fields/s)

FR50I: 50I interlace mode (50 fields/s)

FR50P: 50P progressive mode (50 fields/s)

FR25P: 25P progressive mode (25 fields/s)

* In FR24P and FR24PA modes, the last digit contains the frame conversion sequence information.

When TC, tc and UB are locked to TC IN input, the characters in their icons change to outline characters **TC → **TC**.**

(Continued on the next page)

2 Warnings

REMOTE:

Flashes when device settings of wireless remote control are different.



Blinks when no P2 card is inserted or the card is write protected.

P2 FULL:

Blinks when there is no more space left on the P2 card.

P2 LACK:

Blinks in loop rec mode when there is not enough space left on the P2 card.



Lights when the battery for the internal clock is depleted.

- “Charging the built-in battery” (Page 27 of Vol. 1)

3 Backup unit displays

The following indications show the status of backup units connected to the DVCPRO/DV connector.

The following indications are not displayed when the menu option 1394 CONTROL in the OTHER FUNCTIONS screen is set to OFF.

1394 ● : Recording

1394 II : Recording standby

1394 : The backup unit cannot be controlled.

1394 : No backup unit is connected.

1394 -- : A backup unit is connected but is not in recording or recording standby status.

4 Recording format and system frequency indication

1080i

720P

480i

576i

Recording format

- In 1080i, 720P system mode

AVC-I 100: AVC-Intra 100 format

AVC-I 50: AVC-Intra 50 format

DVCPROHD: DVCPRO HD format

- In 480 (576i) system mode

DVCPRO50, DVCPRO, DV

5 AUTO/MANUAL switch indicator

Indicates when the AUTO/MANUAL switch is set to AUTO.

6 Information display

The following information is displayed depending on the situation.

- Performance of auto white balance and auto black balance
- Warning and error indication
- Information on switch and button operations
- “MODE CHECK indication” (Page 131)

7 System frequency display

60 : Indicates in 59.94 Hz mode

50 : Indicates in 50 Hz mode

8 Letter box recording display

This display appears in the 480i (576i) recording format when LETTER BOX is selected in the menu option ASPECT CONV in the SYSTEM SETUP screen.

9 Y GET brightness display

When the Y GET function is used, the image level at the center of the image is indicated in a range between 0% and 109%.

10 Recording/playback frame rate display

In native recording, the capture frame rate and recording and playback frame rates are displayed.

Example: 60:24PN (recording 60P with the camera-recorder frame rate set to a variable frame rate of 24PN)

Playback applies a 2:3 pull-down to perform 24P over 60P, indicating that 24/60 speed slow playback is performed.

In standard recording only the capture frame rate is indicated.

Example: 24PA (recording 24PA using 2:3:3:2 pulldown for over 60i recording)

11 Audio limiter display

This is displayed when the limiter is set to work on CH1, CH2 or CH3, CH4.

12 Audio level meter display
(Only for AG-HPX250P)

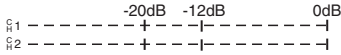

(Only for AG-HPX250EN)

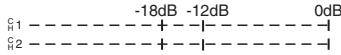

By assigning MAG A. LVL (level meter magnification) to a USER button makes it possible to switch to display magnification.

- “Audio level meter magnification” (Page 55)
- Also, you can switch between level meter display and audio output (excluding 1394) for CH1/2 and CH3/4 while the USER button to which LVL METER has been allocated is held down.
- “Using the USER buttons” (Page 39)

13 Audio recording not possible display

This is displayed when audio recording is not possible during VFR (variable frame rate) mode native recording, interval recording, and one-shot recording.

14 Shutter speed

The shutter speed is displayed here. In synchro scan mode, the display (time (minutes) display or shutter angle icon display) made in the menu option SYNC SCAN TYPE in the SCENE FILE screen is used.

15 DRS display

This indicates operation of the dynamic range stretcher function.

16 Iris display

Displays F values.

17 Auto-iris control displays

- STD:** Standard auto iris control
- SPOT:** Auto iris control for spot light
- BACK:** Auto iris control for backlight compensation

18 Zoom position display

Zoom positions are indicated in a range from Z00 (maximum wide angle) to Z99 (maximum zoom). You can switch the units to mm in ZOOM-FOCUS on the setting menu DISPLAY SETUP screen.

19 Focus control display

Displays the focus control information with 99-00. In the auto focus mode, AF appears. In the manual focus mode, MF appears, and when MF ASSIST is set to ON on the setting menu SW MODE screen, MA appears. When the display is set to macro control, the black and white of AF or MF are displayed in reverse. **95** (Distance to the subject: infinity)

- :
 - 00** (Distance to the subject: approx. 5 cm)
- Depending on the zoom position, the macro range may not be enabled. Also, depending on the zoom position, the lower limit value of macro range may be different. The units can be switched between feet and m in the ZOOM-FOCUS option of the setting menu DISPLAY SETUP screen.

20 Calendar

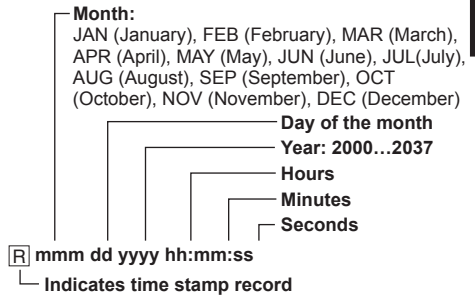

21 Recommended ND filter display

This indicates the most suitable ND filter to use under current shooting conditions.

22 ND filter display

This indicates the selected ND filter.

23 Gain display

Indicates the gain value set using the video amplifier.

24 WHITE BAL switch position indication

Indicates the currently selected switch position and also white balance operation when AWB is preset. In ATW (Auto Tracking White Balance) mode, ATW is also indicated and LOCK is displayed when the function is locked.

25 FBC indication

Appears when the FBC function is engaged.

(Continued on the next page)

Screen displays (continued)





26 Image stabilization display



This is displayed when the OIS button is pressed and image stabilization is activated.

27 Scene file name display

Indicates the name of currently selected SCENE FILE (F1 to F6).

28 Remaining battery charge

As the remaining battery charge drops, the display changes as follows:  →  →  →  .

When the battery is completely discharged,  () blinks.

(When the AC adaptor is being used, a display other than  may appear: this is not a sign of malfunctioning.)

- Remaining battery capacity may not be displayed correctly with use at high or low temperatures, or when the battery has not been used for a long period of time. To ensure that remaining battery capacity is displayed correctly, use the battery completely from a fully-charged state, and charge the battery again. (Remaining battery capacity may still not be displayed correctly if the battery has been used for long periods at high or low temperatures, or if the battery has been recharged a large number of times.)
- The remaining battery capacity display is a guideline and may change according to usage conditions.

29 Digital zoom display

This displays the digital zoom ratio.

D2x: 2x

D5x: 5x

D10x: 10x

30 One-clip recording mode display

1-CLIP:

Indicates that recording has started for a new clip in one-clip recording mode.

1*CLIP:

Indicates that recordings can be compiled to a previous clip in one-clip recording mode.

31 Media remaining memory display

- Set the menu option P2CARD REMAIN in the DISPLAY SETUP screen to ONE-CARD to display the remaining time on the P2 card being recorded and show the number of the slot it resides in on the left. TOTAL displays the remaining time on both cards.
- In a mode check, ONE-CARD and TOTAL are alternately displayed.
- This display does not appear while remaining memory is calculated and when the camera-recorder is in USB device mode.
- A mode check during loop recording displays the standard recording time available to loop recording.
- Indicates remaining time in 1-minute increments from 0 to 999 minutes. 999 minutes and longer time periods are also indicated as 999 minutes.
- The display blinks when 2 minutes or less time is left.

32 Media information display

Indicates the slots that contain P2 cards and general information on the media.

 **On:** P2 card ready for recording

 **lights green:**

P2 card selected for recording

 **flashes:** The card is being recognized

 **-:** No card inserted

 **P:** Write-protected

 **F:** Full

 **X:** Cannot recognize

 **E:** P2 card in an invalid format (formatting will take care of this problem)

33 Recording and playback

REC : Recording

PAUSE : Recording standby

II : Playback pause

▶ : Play

◀▶ (◀▶) :

Slow play (Reverse slow play)

◀▶▶ (◀▶▶) :

Frame-by-frame (Reverse Frame-by-frame)

▶▶ (◀◀) :

Fast-forward/Fast-backward play (Rewind/Fast-backward play)

×>/×>> (×</×<<) :

Variable-speed search (Reverse variable-speed search)

CLIP II ▶ (CLIP ◀ II) :

Clip forward (clip reverse), cue up of single clips

CLIP & T II ▶ (CLIP & T ◀ II) :

Cue forward (cue back) to the start point of clips and text memo points (when the menu option SEEK SELECT is set to CLIP&T in the OTHER FUNCTIONS screen)

START:

Indicates that recording has started for a new clip in one-clip recording mode.

END:

Indicates that compiling to a clip has stopped in one-clip recording mode.

During DISPLAY OFF, only the REC, START, and END displays are shown at the top right. Also displayed at top right, when pre-recording, loop recording, interval recording or one-shot recording is set.

Special recording display

This display appears when the menu option REC FUNCTION in the RECORDING SETUP screen is set to INTERVAL, ONE SHOT or LOOP and when PRE REC is set to ON.

L -: LOOP (loop recording)

I -: INTERVAL (interval recording), ONE SHOT (one-shot recording)

P -: PRE REC (pre-rec recording)

Center information display

The following information displays (Page 122) are provided.

P2 card recording and playback data indications

BOS

Beginning of stream. No more data is available in the rearward playback direction.

CANNOT PLAY

Appears when playback is disabled.

CARD ERR (1) (2) (1/2):

The number identifies the P2 card that is giving trouble.

UPDATING: Reading card data

CANNOT REC

Appears when recording cannot be started by pressing the START/STOP button.

EOS

End of stream. No more data is available in the forward playback direction.

PRE REC ON (OFF) (INVALID)

Appears when the USER button to which pre-recording has been assigned is pressed.

SHOT MARK ON (OFF) (INVALID)

Appears when pressing the USER button to which SHOT MARK is assigned.

SLOT SEL (INVALID)

Appears when pressing the USER button to which SLOT SEL is assigned.

TEXTMEMO (INVALID)

Appears when pressing the USER button to which TEXTMEMO is assigned.

VFR ON NO AUDIO RECORDING

Appears when audio signal cannot be recorded with VFR recording.

Errors and warnings

Errors and warnings appear when something goes wrong with the camera-recorder or a P2 card malfunctions. If the problem cannot be solved by turning off the camera-recorder and turning it back on, try replacing the card and if that does not help, it may be necessary to consult your supplier.

1394

This error occurs in a 1394 connection or when signal faults occur.

1394 INITIAL ERROR: a connection error

1394 INPUT ERROR: an input error

1394 INPUT ERROR (OTHER FORMAT):
(different input format)

COPY INHIBITED:

This indicates that a copy-guarded signal entered DV format input from the DVCPRO/DV connector.

CLIP DISCONTINUED

This message appears in one-clip recording mode when conformity errors occur in a complied clip and the next recording cannot be complied to the clip.

DIR ENTRY NG CARD

This message indicates that the directory on the card has become corrupted and that normal recording cannot be guaranteed if operation continues. Make a quick backup of card data and reformat the card.

EXTERNAL1394 DISCONNECT

This message appears when the menu option 1394 CONTROL in the OTHER FUNCTIONS screen is set to EXT and recording is attempted without connecting an external device to the DVCPRO/DV connector.

FAN STOPPED

The fan has stopped.

Turn the power off immediately, discontinue use, and contact your dealer.

FAN STOPPED HIGH TEMPERATURE

Due to the fan stopping, the interior of the camera-recorder has become very hot. The power switches off automatically. Discontinue use and contact your dealer.

FORMAT ERR !

This indicates a P2 card that does not meet the P2 card standard.

INCOMPATIBLE CARD

This message indicates that the inserted card does not meet required standards and cannot be used.

LOW BATTERY

This message indicates that the battery is depleted.

PULL DOWN ERROR

Video pull-down sequence error in a mode such as 24P

REC WARNING

This is displayed during a recording error. Do the recording over. If this does not solve the problem, consult your supplier.

CARD ERR (1) (2) (1/2)

The number indicates the P2 card that is giving trouble.

- Turn the power off if the warning continues.
- If the warning persists after rerecording, replace the card with another card.

ERROR: Other causes

OVER MAX# CLIPS:

The limit for the number of clips that can be recorded to one P2 card (up to 1000 clips) is reached, and recording stops.

REC RAM OVERFLOW:

Overflow of recording memory

RUN DOWN CARD

This message indicates that a P2 card has been overwritten the maximum number of times and that normal recording cannot be guaranteed if operation continues.

It is best to replace such P2 cards with a new card.

SYSTEM ERROR

This message indicates that a system error has occurred. This type of error can often be corrected by turning off the power and turning it back on again.

CAM MICON ERROR:

The microprocessor in the camera-recorder is not responding.

P2 CONTROL ERROR:

a P2 control error has occurred.

P2 MICON ERROR:

The P2 microprocessor does not respond.

CAN LENS ERROR:

a camera-recorder lense error has occurred.

TEMPORARY PAUSE

IRREGULAR FRM SIG:

This message indicates that the input GENLOCK reference signal is irregular and that recording has been paused.

TURN POWER OFF

This message indicates that an abnormal event has occurred, for example, that a card was removed during access or that a system mode change was made.

Turn the power off and then turn it back on again.

Camera-recorder status display (in alphabetical order)

ABB

ABB indicator

ATW ACTIVE

Appears when the AWB button is pressed and ATW is running.

ATW (ATW LOCK)

Appears when the WHITE BAL switch is set to B and ATW has been assigned.

AWB

AWB indicator

AWB P3.2K/AWB P5.6K

Displays the color temperature assigned to PRST when the WHITE BAL switch is set to PRST. Also displayed when AWB is performed in the PRST position.

BACK LIGHT

Displayed during iris control when back light status is changed by pressing the user button to which BACK LIGHT is assigned.

DIAL: FRAME RATE (SHUTTER/SYNCHRO SCAN/LOCK)

This is displayed when you switch shutter/frame rate dial using the dial select button.

DRS ON (OFF)

Displayed when DRS operation has been changed.

D.ZOOM 10x (2x/5x/OFF/INVALID)

This is displayed when you switch the operation of the digital zoom.

FBC ON (OFF)

Displayed when FBC operation has been changed.

GAIN**dB

Displayed when GAIN is switched.

IRIS: MANUAL (AUTO)

This is displayed when you switch the iris operation.

OIS ON (OFF)

This indicates that the image stabilization function has been switched on or off.

SCENE*****

Displays the name of a scene file selected by turning the SCENE FILE dial.

Screen displays (continued)

SHUTTER 1/**** (OFF)

Displayed when the shutter speed is changed.

SPOT LIGHT

Displayed during iris control when back light status is changed by pressing the USER button to which SPOT LIGHT is assigned.

VFR ON (OFF)

Displayed when VFR operation has been changed

Checking and displaying shooting status

- Hold down the DISP/MODE CHK button in recording standby or during recording to display the settings of each shooting function, the list of functions assigned to USER buttons and all other information. Release the button to return to the regular screen.
- Press the DISP/MODE CHK button during recording standby or recording clears all displays. Press again to return to the regular display.
- These settings are maintained when the unit is turned off and also when switching media and operating mode.
- The following items can be displayed in the viewfinder and on the LCD monitor by pressing the DISP/MODE CHK button or by configuring the menu option OTHER DISPLAY in the DISPLAY SETUP screen.

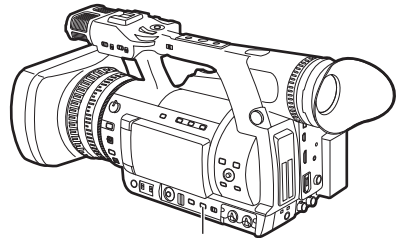

DISP/MODE CHK button

No	Displays	Displays that MODE CHECK brings up √	Displays that DISPLAY OFF clears √	Displays opened or hidden by settings in the OTHER DISPLAY option –: Not affected, √: Opens, x: Clears			Other menus that clear displays –: Not affected
				ALL	PARTIAL	OFF	
1	Time code displays	√	Is not cleared	–	–	–	–
2	Warnings	√	Is not cleared	–	–	–	CARD&BATTERY ¹
3	Backup unit displays	√	Is not cleared	–	–	–	–
4	Recording format and system frequency indication	√	√	√	x	x	–
5	AUTO/MANUAL switch indicator	√	√	√	√	x	–
6	Information display	x	Is not cleared	–	–	–	–
7	System frequency display	√	√	√	x	x	–
8	Letter box recording display	√	√	–	–	–	–
9	Y GET brightness display	√	Is not cleared	–	–	–	–
10	Recording/playback frame rate display	√	√	√	√	x	–
11	Audio limiter display	√	√	√	x	x	–
12	Audio level meter display	√	√	–	–	–	LEVEL METER
13	Audio recording not possible display	√	√	–	–	–	–
14	Shutter speed	√	√	√	√	x	–
15	DRS display	√	√	√	√	x	–
16	Iris display	√	√	√	√	x	–
17	Auto-iris control displays	√	√	√	√	x	–
18	Zoom position display	√	√	–	–	–	ZOOM-FOCUS
19	Focus control display	√	√	–	–	–	ZOOM-FOCUS
20	Calendar	√	√ ²	–	–	–	DATE/TIME
21	Recommended ND filter display	√	√	√	√	x	–
22	ND filter display	√	√	√	x	x	–
23	Gain display	√	√	√	√ Does not indicate 0 dB	x	–
24	WHITE BAL switch position indication	√	√	√	√ Displays only ATW, LOCK, P3.2K and P5.6K	x	–
25	FBC indication	√	√	√	√	x	–
26	Image stabilization display	√	√	√	√	x	–
27	Scene file name display	√	√	√	x	x	–
28	Remaining battery charge	√	√ Goes on when battery charge drops	–	–	–	CARD&BATTERY
29	Digital zoom display	√	√	–	–	–	–

(Continued on the next page)

Screen displays (continued)

No	Displays	Displays that MODE CHECK brings up √	Displays that DISPLAY OFF clears √	Displays opened or hidden by settings in the OTHER DISPLAY option –: Not affected, √: Opens, x: Clears			Other menus that clear displays –: Not affected
				ALL	PARTIAL	OFF	
30	One-clip recording mode display	√	√	√	√	x Appears when recording to a clip is started or stopped	–
31	Media remaining memory display	√	√ Goes on when battery charge drops	–	–	–	CARD&BATTERY
32	Media information display	√	√ Lights when SLOT SEL is performed	–	–	–	CARD&BATTERY
33	Recording and playback	√	√ Appears at top right only during recording and in special recording	√	√	x Appears at top right only during recording and in special recording modes	–

√: Displayed

x: Not displayed

–: Displayed depending on other settings

*1: Only the warning that a P2 card has not been inserted is not displayed.

*2: When the “” is activated, the displays cannot be turned off by pressing the DISP/MODE CHK button.

MODE CHECK indication

MODE CHECK provides an almost complete set of camera-recorder information. Items 1 to 3 below are provided only by MODE CHECK.

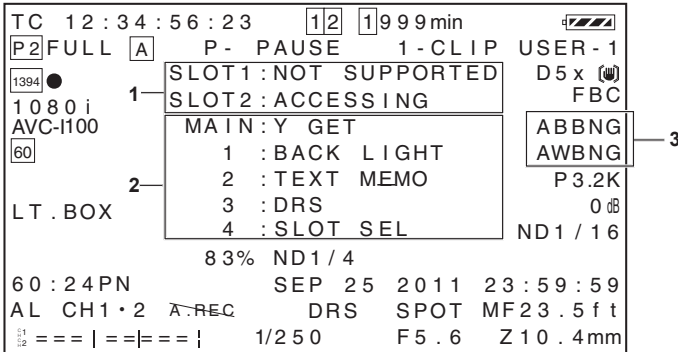

1 P2 card slot status display

Displays status for P2 card slots 1 and 2.

ACTIVE:

Indicates cards that are ready for read and write operations (includes cards selected for recording)

ACCESSING:

Indicates a card that is currently read or being written to

INFO READING:

Card in the recognition phase

FULL:

No more space available on the P2 card

PROTECTED:

The P2 card is write-protected.

NOT SUPPORTED:

The P2 card cannot be used or recognized.

FORMAT ERROR:

The P2 card is not properly formatted.

NO CARD:

No card has been inserted.

No indication:

The camera-recorder is in the USB DEVICE mode.

2 USER button allocation information display

This displays information for the function allocated to each USER button.

- "Using the USER buttons" (Page 39)

3 AWB, ABB error display

A mode check indicates when AWB and ABB fail to operate normally.

Setup menu list

SCENE FILE screen

Item	Setting	Notes
LOAD/SAVE/INIT	<p>Loads, saves and initializes settings of the scene file assigned to the current scene dial position (one F1 – F6 scene file).</p> <p>LOAD: Loads data stored in camera-recorder memory.</p> <p>SAVE: Saves current values in camera-recorder memory.</p> <p>INITIAL: Returns settings to their factory defaults.</p>	<ul style="list-style-type: none"> • A change in scene files affects only the scene file at the current scene dial position. • This setting cannot be made when REC SIGNAL is 1394. • Not available when compiling to a clip in one-clip recording mode.
VFR	<p>Enables or disables variable frame rate (VFR) mode at 1080i or 720P.</p> <p>ON: VFR operation</p> <p>OFF:*1 VFR off</p>	<ul style="list-style-type: none"> • Not displayed when system mode is 480i/576i. • This setting cannot be made when REC SIGNAL is 1394. • Cannot be set when 1080i is selected with DVCPRO HD recording and CAMERA MODE is not set to 60i, 50i.
FRAME RATE	<p>Adjusts the frame rate and exposure time at 1080i or 720P when VFR is on.</p> <ul style="list-style-type: none"> • 1080-59.94i: 1, 2, 4, 6, 9, 12, 15, 18, 20, 21, 22, 24, 25, 26, 27, 28, <u>30</u> FRAME • 1080-50i: 1, 2, 4, 6, 9, 12, 15, 18, 20, 21, 22, 23, 24, <u>25</u> FRAME • 720-59.94P: 1, 2, 4, 6, 9, 12, 15, 18, 20, 21, 22, 24, 25, 26, 27, 28, 30, 32, 34, 36, 40, 44, 48, 54, <u>60</u> FRAME • 720-50P: 1, 2, 4, 6, 9, 12, 15, 18, 20, 21, 22, 23, 24, 25, 26, 27, 28, 30, 32, 34, 37, 42, 45, 48, <u>50</u> FRAME 	<ul style="list-style-type: none"> • Can only be set when VFR is ON. • This setting cannot be made when REC SIGNAL is 1394. • A change to 24 fps may cause the screen to flicker momentarily.
SYNC SCAN TYPE	<p>Selects synchro scan shutter display.</p> <p>sec: Displays the shutter speed in fractions.</p> <p>deg: Displays the approximate shutter opening angle.</p>	<ul style="list-style-type: none"> • Brightness may change when settings are switched.
(SYNCHRO SCAN)	<p>Displays synchro scan shutter speeds to enable the operator to synchronize the camera-recorder to computer monitors.</p> <ul style="list-style-type: none"> • This function only displays the shutter speeds. Use the SHTR/F.RATE dial to set a shutter speed. • Set values (displayed values) are assigned to the current scene file and manipulated using the LOAD, SAVE and INIT functions. <p>“Setting SYNCHRO SCAN mode” (Page 50)</p> <p>1/60.0 (AG-HPX250P) 1/50.0 (AG-HPX250EN)</p>	<ul style="list-style-type: none"> • Displayed in blue when not set to synchro scan mode and when the SHTR/F.RATE dial settings are not available.
DETAIL LEVEL	<p>Adjusts the level of image outline correction (in horizontal and vertical directions).</p> <p>– 7 ...<u>0</u>*1... +7</p>	
V DETAIL LEVEL	<p>Adjusts the level of correction in vertical direction.</p> <p>– 7 ...<u>0</u>*1... +7</p>	

*1: The factory default when the SCENE FILE dial is set to F1.

___ indicates the factory setting.

SCENE FILE screen (continued)

Item	Setting	Notes
DETAIL CORING	Adjusts the level of noise reduction of the detail signal. – 7 ... <u>0</u> *1... +7 • Adjust towards – for a clearer image. Noise increases slightly. • Adjust towards + for less noise.	
CHROMA LEVEL	Adjusts the chroma level. – 7 ... <u>0</u> *1... +7	
CHROMA PHASE	Makes fine adjustments to the chroma phase. – 7 ... <u>0</u> *1... +7	
COLOR TEMP Ach	Makes fine adjustments to the color temperature (after Ach white balance adjustment). – 7 ... <u>0</u> *1... +7	
COLOR TEMP Bch	Makes fine adjustments to the color temperature (after Bch white balance adjustment). – 7 ... <u>0</u> *1... +7	
MASTER PED	Adjusts the black master pedestal that serves as the video reference. – 100 ... <u>+15</u> *1... +100	• Values change quickly when the Operation lever is held in the ▲ ▼ direction.
A. IRIS LEVEL	Sets the AUTO IRIS target value. – 10 ... <u>0</u> *1... +10	
DRS	Sets whether to operate the DRS (dynamic range stretcher) function. ON, OFF *1	• When using 1080i, the DRS function is not available if shooting with 24P, 30P, 25P, or VFR (variable frame rate) even if you select ON.
DRS EFFECT	Sets the compression level in high-brightness areas of the DRS (dynamic range stretcher) function. This function compresses the video signal level to extend the dynamic range making it possible to correctly render highlight areas without overexposure and loss of detail that would otherwise occur. 1, 2, 3 *1 • Higher numbers mean a higher compression level of high-brightness areas and more noise in dark areas.	
GAMMA	Selects the gamma curve. HD NORM: *1 Gamma setting for HD recording. LOW: Applies a gently rising gamma curve to lowbrightness areas for a balanced look. SD NORM: Normal video setting inherited from the DVX100 series. HIGH: Applies a steep gamma curve to low brightness areas to expand the tonality of dark areas for video with greater brightness. Contrast softens as a result. B.PRESS: Produces sharper contrast than LOW. CINELIKE D: Applies a gamma curve to produce video with a cine-like feel. CINELIKE V: Applies a gamma curve to produce high-contrast video with a cine-like feel. • A lens aperture set lower than normal video level (approx. 1/2) is recommended when using cine-like gamma to enjoy the full benefit of the function.	• A change in settings during DRS operation will not change video quality.

*1: The factory default when the SCENE FILE dial is set to F1.

___ indicates the factory setting.

Setup menu list (continued)

SCENE FILE screen (continued)

Item	Setting	Notes
KNEE	<p>Sets the compression level (knee point) of the high brightness video signals received through the MOS sensor to avoid overexposure.</p> <p>AUTO: *1 Sets the level automatically according to the received signals.</p> <p>HIGH: High setting (compression starts at approx. 100 %)</p> <p>MID: Medium setting (compression starts at approx. 90 %)</p> <p>LOW: Low setting (compression starts at approx. 80 %)</p>	<ul style="list-style-type: none"> • A change in settings during DRS operation will not change video quality.
MATRIX	<p>Selects the MATRIX table to reproduce color during shooting.</p> <p>NORM 1: *1 Ensures proper color rendition when shooting out in the open or under halogen lighting.</p> <p>NORM: Produces more vivid colors than NORM1.</p> <p>FLUO: Ensures proper color rendition when shooting indoors under fluorescent lighting.</p> <p>CINE-LIKE: Produces a tone similar to movie film.</p>	
SKIN TONE DTL	<p>Turns the skin tone detail on or off. When on, reduces detail to hide any skin blemishes.</p> <p>ON*1, OFF</p>	
V DETAIL FREQ	<p>Sets vertical detail.</p> <p>THIN: *1 Produces fine detail.</p> <p>MID: Produces less detail and wider edging.</p> <p>THICK: Produces even less detail and the widest edging effect.</p> <ul style="list-style-type: none"> • Progressive recording made at THIN or MID cause horizontal lines or oblique lines that are almost horizontal to flicker when viewed on a normal monitor TV (60i (50i): Interlace). THIN and MID settings will produce higher resolution video than THICK when shooting progressive footage that will later be edited. 	
NAME EDIT	<p>Edits the name of scene files selected using the SCENE FILE dial.</p>	

*1: The factory default when the SCENE FILE dial is set to F1.

___ indicates the factory setting.

SYSTEM SETUP screen

Item	Setting	Notes
SYSTEM MODE	<p>Specifies the signal format used by this camera-recorder.</p> <p>1080-59.94i, 1080-50i, 720-59.94P, 720-50P, 480-59.94i, 576-50i</p> <p>Factory setting: 1080-59.94i (only for AG-HPX250P)</p> <p>Factory setting: 1080-50i (only for AG-HPX250EN)</p> <ul style="list-style-type: none"> When a setting is changed, the message "TURN POWER OFF" appears. Then turn the power off and turn it back on again. 	<ul style="list-style-type: none"> Not available when compiling to a clip in one-clip recording mode.
REC SIGNAL	<p>Selects the input signal in the DVCPRO format.</p> <p>CAMERA: Records the camera-recorder recording signal.</p> <p>1394: Records signals input to the DVCPRO/DV connector.</p> <ul style="list-style-type: none"> This function is always set to CAMERA when the power is turned on. 	<ul style="list-style-type: none"> Not available when the menu option REC FORMAT is set to AVC-Intra or DVCPROHD during native recording. Not available when compiling to a clip in one-clip recording mode.
REC FORMAT	<p>Selects the recording codec as well as shooting and recording modes.</p> <p>■ When SYSTEM MODE is set to 1080-59.94i AVC-I100/60i, AVC-I100/30PN, AVC-I100/24PN: Uses the AVC-I 100 codec for recording. Shooting and recording at 60i, 30PN (native recording) and 24PN (native recording).</p> <p>AVC-I 50/60i, AVC-I 50/30PN, AVC-I 50/24PN: Uses the AVC-I 50 codec for recording. Shooting and recording at 60i, 30PN (native recording) and 24PN (native recording).</p> <p>DVCPROHD/60i: Uses the DVCPRO HD codec for recording. Use CAMERA MODE options to set shooting mode. Recording is locked to 60i.</p> <p>■ When SYSTEM MODE is set to 1080-50i AVC-I100/50i, AVC-I100/25PN: Uses the AVC-I 100 codec for recording. Shooting and recording at 50i, 25PN (native recording) and 24PN (native recording).</p> <p>AVC-I 50/50i, AVC-I 50/25PN: Uses the AVC-I 50 codec for recording. Shooting and recording at 50i, 25PN (native recording) and 24PN (native recording).</p> <p>DVCPROHD/50i: Uses the DVCPRO HD codec for recording. Use CAMERA MODE options to set shooting mode. Recording is locked to 50i.</p>	<ul style="list-style-type: none"> Not available when 1080i or 720P is set in SYSTEM MODE and REC SIGNAL is 1394. Not available when compiling to a clip in one-clip recording mode.

___ indicates the factory setting.

Setup menu list (continued)

SYSTEM SETUP screen (continued)

Item	Setting	Notes
REC FORMAT (continued)	<p> ■ When SYSTEM MODE is 720-59.94P AVC-I100/60P, AVC-I100/30PN, AVC-I100/24PN: Uses the AVC-I 100 codec for recording. Shooting and recording at 60P, 30PN (native recording) and 24PN (native recording). AVC-I 50/60P, AVC-I 50/30PN, AVC-I 50/24PN: Uses the AVC-I 50 codec for recording. Shooting and recording at 60P, 30PN (native recording) and 24PN (native recording). DVCPROHD/60P, DVCPROHD/30PN, DVCPROHD/24PN: Uses the DVCPRO HD codec for recording. Shooting and recording at 60P, 30PN (native recording) and 24PN (native recording). </p> <p> ■ When SYSTEM MODE is 720-50P AVC-I100/50P, AVC-I100/25PN: Uses the AVC-I 100 codec for recording. Shooting and recording at 50P, 25PN (native recording). AVC-I 50/50P, AVC-I 50/25PN: Uses the AVC-I 50 codec for recording. Shooting and recording at 50P, 25PN (native recording). DVCPROHD/50P, DVCPROHD/25PN: Uses the DVCPRO HD codec for recording. Shooting and recording at 50P, 25PN (native recording). </p> <p> ■ When SYSTEM MODE is 480-59.94i DVCPRO50/60i, DVCPRO/60i, DV/60i: These use DVCPRO50, DVCPRO and DV codecs, respectively. Use CAMERA MODE options to set shooting mode. Recording is locked at 60i. </p> <p> ■ When SYSTEM MODE is 576-50i DVCPRO50/50i, DVCPRO/50i, DV/50i: These use DVCPRO50, DVCPRO and DV codecs, respectively. Use CAMERA MODE options to set shooting mode. Recording is locked at 50i. </p>	<ul style="list-style-type: none"> • Not available when 1080i or 720P is set in SYSTEM MODE and REC SIGNAL is 1394. • Not available when compiling to a clip in one-clip recording mode.
CAMERA MODE	<p>Sets the shooting mode of the camera-recorder during DVCPRO HD codec or SD mode at 1080i.</p> <ul style="list-style-type: none"> • When SYSTEM MODE is set to 1080-59.94i or 480-59.94i 60i, 30P, 24P, 24PA • When SYSTEM MODE is set to 1080-50i, 576-50i 50i, 25P 	<ul style="list-style-type: none"> • Does not appear when SYSTEM MODE is set to 720P. • Not available in the following conditions. <ul style="list-style-type: none"> · When the REC SIGNAL is set to 1394. · When the SYSTEM MODE setting is 1080i and the REC FORMAT setting is AVC-Intra codec or VFR is ON. · When compiling to a clip in one-clip recording mode.
SCAN REVERSE	Cancels the image inversion that occurs with film lenses and anamorphic lenses. (Page 35) ON, OFF	

___ indicates the factory setting.

SYSTEM SETUP screen (continued)

Item	Setting	Notes
ASPECT CONV	<p>Selects the aspect ratio for recording at 480i, 576i.</p> <p><u>SIDE CROP:</u> Crops the right and left edges of the image.</p> <p><u>LETTER BOX:</u> Adds black bands at the top and bottom of the image.</p> <p><u>SQUEEZE:</u> Compresses the image horizontally.</p>	<ul style="list-style-type: none"> • Not available when SYSTEM MODE is set to 1080i or 720P. • Not available when compiling to a clip in one-clip recording mode.
SETUP	<p>Sets the setup level of 480i video signals.</p> <p><u>0%:</u> Setup is switched to 0 % for both output and recording signals.</p> <p><u>7.5% A:</u> Setup is switched to 7.5 % for the output signal and 0 % for the recording signal.</p>	<ul style="list-style-type: none"> • Not displayed in 1080-50i, 720-50P, 576-50i.
PC MODE SELECT	<p>Sets camera-recorder operating mode when an external device is connected via USB.</p> <p><u>USB HOST:</u> Selects USB 2.0 for connecting an external hard disk drive. (Page 111)</p> <p><u>USB DEVICE:</u> Makes it possible to connect the camera-recorder to a personal computer via USB 2.0 to enable use of a P2 card as mass storage. (Page 109)</p>	

___ indicates the factory setting.

Setup menu list (continued)

SW MODE screen

Item	Setting	Notes
LOW GAIN	Sets the gain value assigned to the L position of the GAIN switch. 0dB, 3dB, 6dB, 9dB, 12dB, 15dB, 18dB	• Fixed to 0 dB when the frame rate is set to 4FRAME or lower in VFR mode.
MID GAIN	Sets the gain value assigned to the M position of the GAIN switch. 0dB, 3dB, 6dB, 9dB, 12dB, 15dB, 18dB	• Fixed to 0 dB when the frame rate is set to 4FRAME or lower in VFR mode.
HIGH GAIN	Sets the gain value assigned to the H position of the GAIN switch. 0dB, 3dB, 6dB, 9dB, 12dB, 15dB, 18dB	• Fixed to 0 dB when the frame rate is set to 4FRAME or lower in VFR mode.
SUPER GAIN	Configures super gain allocated to a USER button. 24dB, 30dB BOTH: Cycles to the next value in the order 24 dB → 30 dB → OFF when pressed.	• Fixed to 0 dB when the frame rate is set to 4FRAME or lower in VFR mode.
ATW	Allows you to assign the ATW (Auto Tracking White Balance) function to the WHITE BAL switch. (Page 33) Bch: Controls the ATW function when the WHITE BAL switch is set to B position. OFF: Does not assign the ATW function to the WHITE BAL switch.	• A USER button to which ATW has been assigned cannot be used to turn ATW off when the WHITE BAL switch is set to B position and this menu is set to Bch. • ATW is not available when the frame rate is set to 4FRAME or lower in VFR mode.
HANDLE ZOOM	Sets the zoom speed allocated to each position of the HANDLE ZOOM switch. L/OFF/H: Sets LOW/OFF/HIGH to positions 1/2/3 respectively. (Zoom does not operate when the setting is OFF.) L/M/H: Sets LOW/MID/HIGH to positions 1/2/3 respectively. L/OFF/M: Sets LOW/OFF/MID to positions 1/2/3 respectively. (Zoom does not operate when the setting is OFF.)	
W.BAL.PRESET	Sets the color temperature assigned to the PRST position of the WHITE BAL switch. 3.2K, 5.6K	

___ indicates the factory setting.

SW MODE screen (continued)

Item	Setting	Notes
USER MAIN	Sets the function assigned to the USER MAIN button. SPOTLIGHT, BACKLIGHT, ATW, ATWLOCK, S.GAIN, D.ZOOM, Y GET, DRS, TEXT MEMO, SLOT SEL, SHOT MARK, MAG A. LVL, LVL METER, PRE REC, WFM, LAST CLIP, FBC, LCD B.L "Using the USER buttons" (Page 39)	
USER1	Sets a function assigned to the USER1 button. The functions that can be assigned to this button are the same as for the USER MAIN button. BACKLIGHT (factory default setting) "Using the USER buttons" (Page 39)	
USER2	Sets a function assigned to the USER2 button. The functions that can be assigned to this button are the same as for the USER MAIN button. TEXT MEMO (factory default setting) "Using the USER buttons" (Page 39)	
USER3	Sets a function assigned to the USER3 button. The functions that can be assigned to this button are the same as for the USER MAIN button. DRS (factory default setting) "Using the USER buttons" (Page 39)	
USER4	Sets a function assigned to the USER4 button. The functions that can be assigned to this button are the same as for the USER MAIN button. SLOT SEL "Using the USER buttons" (Page 39)	
MF ASSIST	Automatically sets the last focus during manual focusing. ON: Automatically sets the last focus. • The focus may not be set correctly if the last focus differs considerably from the manually set focus. • You cannot operate using the remote control connected to the CAM REMOTE jack. OFF: The focus is not adjusted automatically.	
WFM	Selects the waveform displayed in the LCD monitor when the user button to which WFM has been assigned is pressed. WAVE: Displays a waveform. VECTOR: Vectorscope display WAVE/VECT: Each press of the button, switches the settings in the following order: OFF → WAVE (waveform) → VECTOR → OFF	

___ indicates the factory setting.

Setup menu list (continued)

AUTO SW screen

Item	Setting	Notes
A.IRIS	<p>ON: Performs the auto iris control in auto mode. The IRIS button is deactivated.</p> <p>OFF: Deactivates the auto iris control in auto mode. This performs the iris control selected with the IRIS button.</p>	<ul style="list-style-type: none"> Auto operation switches OFF when the frame rate is set to 4FRAME or lower in VFR mode.
AGC	<p>Sets the Auto Gain Control when the ON is selected in A.IRIS.</p> <p>6dB: Performs the Auto Gain Control (max. 6 dB) in auto mode.</p> <p>12dB: Performs the Auto Gain Control (max. 12 dB) in auto mode.</p> <p>18dB: Performs the Auto Gain Control (max. 18 dB) in auto mode.</p> <p>OFF: Does not perform the Auto Gain Control in auto mode. Initiates the control of the gain selected by the GAIN switch.</p>	<ul style="list-style-type: none"> Cannot be set when A.IRIS is OFF. Auto operation switches OFF when the frame rate is set to 4FRAME or lower in VFR mode. AGC does not operate when a USER button to which S.GAIN has been allocated is pressed and super gain is set to 24 dB or 30 dB.
ATW	<p>ON: Performs the ATW (Auto Tracing White Balance) function in auto mode. You cannot select ON/OFF of the ATW function with the WHITE BAL switch or the USER button when this is selected. However, if ATWLOCK is assigned to the USER button, you can set the white balance value with the USER button.</p> <p>OFF: Does not perform the white balance function in auto mode. This performs the white balance function selected with the WHITE BAL switch.</p>	<ul style="list-style-type: none"> Auto operation switches OFF when the frame rate is set to 4FRAME or lower in VFR mode.
AF	<p>ON: Performs auto focusing in auto mode. You cannot use the FOCUS switch and PUSH AUTO button when this is selected.</p> <p>OFF: Does not perform auto focusing in auto mode. This performs the focusing selected with the FOCUS switch or PUSH AUTO button.</p>	<ul style="list-style-type: none"> Auto operation switches OFF when the frame rate is set to 4FRAME or lower in VFR mode.

___ indicates the factory setting.

RECORDING SETUP screen

Item	Setting	Notes
REC FUNCTION	<p>Sets special recording modes.</p> <p>NORMAL: The special recording modes are not used.</p> <p>INTERVAL: Sets interval recording.</p> <p>ONE SHOT: Sets one-shot recording.</p> <p>LOOP: Sets loop recording.</p> <p>"Using special recording modes" (Page 43)</p> <ul style="list-style-type: none"> This function is always set to NORMAL when the power is turned on. 	<ul style="list-style-type: none"> Not available in the following conditions. <ul style="list-style-type: none"> When REC SIGNAL is set to 1394 When REC FORMAT is set to native recording. When SYSTEM MODE is set to 1080-59.94i or 480-59.94i; and CAMERA MODE is set to 24P or 24PA. When compiling to a clip in one-clip recording mode. When VFR is set to ON.
ONE SHOT TIME	<p>Sets the duration for one-shot recording.</p> <p>1frm, 2frm, 4frm, 8frm, 16frm, 1s</p> <p>"One-shot recording (ONE SHOT REC)" (Page 45)</p>	<ul style="list-style-type: none"> Can only be set when REC FUNCTION is ONE SHOT.
INTERVAL TIME	<p>Sets the time interval of interval recording.</p> <p>2frm, 4frm, 8frm, 16frm, 1s, 2s, 5s, 10s, 30s, 1min, 5min, 10min</p> <p>"Interval recording (INTERVAL REC)" (Page 44)</p>	<ul style="list-style-type: none"> Can only be set when REC FUNCTION is INTERVAL.
START DELAY	<p>This delays the start of interval and one-shot recording by about 1 second.</p> <p>ON, OFF</p>	<ul style="list-style-type: none"> Can only be set when REC FUNCTION is INTERVAL or ONE SHOT.
PREREC MODE	<p>Sets PRE REC.</p> <p>ON, OFF</p> <p>"Pre-recording (PRE REC)" (Page 44)</p>	<ul style="list-style-type: none"> Not available in the following conditions. <ul style="list-style-type: none"> When REC SIGNAL is set to 1394. When VFR is set to ON. When REC FORMAT is set to native recording. When SYSTEM MODE is set to 1080-59.94i or 480-59.94i; and CAMERA MODE is set to 24P or 24PA. When REC FUNCTION is set to something other than NORMAL.
TC MODE	<p>Sets count correction when using the internal time code generator.</p> <p>DE: Drop frame time code</p> <p>NDF: Non drop frame time code</p> <p>"Setting the time code" (Page 66)</p>	<ul style="list-style-type: none"> Not displayed in 1080-50i, 720-50P, 576-50i. Not available when operates 24P, 24PA or 24PN mode. Counts NDF time code in 24P, 24PA or 24PN mode.
TCG	<p>Sets the mode in which you advance the time code.</p> <p>FREE RUN: The time code is advanced regardless of the operation mode.</p> <ul style="list-style-type: none"> In native recording in VFR mode, if the number of frames differs for shooting and recording, the time code changes to REC RUN. <p>REC RUN: The time code is advanced only when recording.</p>	

___ indicates the factory setting.

Setup menu list (continued)

RECORDING SETUP screen (continued)

Item	Setting	Notes
TC PRESET	Sets the initial time code. <ul style="list-style-type: none"> Set the frame value to 0 or multiples of 5 when shooting/recording is set to 24P, 24PA, or 24PN. If any other value, the recorded time code will mismatch.	
UB MODE	Sets the data recorded in the camera-recorder user bits. USER, TIME, DATE, EXT, TCG, FRM. RATE "Setting user bits" (Page 62)	
UB PRESET	Sets the user information. Select USER in UB MODE.	
ONE CLIP REC	Sets one-clip recording mode. ON, OFF "One-clip recording (ONE CLIP REC)" (Page 47)	<ul style="list-style-type: none"> Not available in the following conditions. <ul style="list-style-type: none"> When REC FUNCTION is set to something other than NORMAL. When REC SIGNAL is set to 1394. When VFR is set to ON.
START TEXT MEMO	Sets whether to automatically add a text memo at the recording start position each time you start recording. ON, OFF	<ul style="list-style-type: none"> Not available when REC FUNCTION is set to something other than NORMAL. The text memo that is added when this is set to ON indicates the recording start position. For details on recording the text memo as text information, refer to "Setting of clip meta data" (Page 87).
TIME STAMP	Determines whether or not date and time information will be superimposed on the image. ON: Superimposes date and time information on the image. OFF: Does not superimpose date and time information on the image. <Note> When DATE/TIME on the DISPLAY SETUP screen is set to OFF, the date and time information is not superimposed.	

___ indicates the factory setting.

AUDIO SETUP screen

Item	Setting	Notes
LIMITER CH1	Sets the CH1 limiter. ON, OFF	<ul style="list-style-type: none"> When the AUDIO AUTO/MANU CH1 switch is set to AUTO and auto adjustment mode is active, the limiter is disabled regardless of these settings.
LIMITER CH2	Sets the CH2 limiter. ON, OFF	<ul style="list-style-type: none"> When the AUDIO AUTO/MANU CH2 switch is set to AUTO and auto adjustment mode is active, the limiter is disabled regardless of these settings.
LIMITER CH3	Sets the CH3 limiter. ON, OFF	<ul style="list-style-type: none"> When the AUDIO AUTO/MANU CH3 switch is set to AUTO and auto adjustment mode is active, the limiter is disabled regardless of these settings.
LIMITER CH4	Sets the CH4 limiter. ON, OFF	<ul style="list-style-type: none"> When the AUDIO AUTO/MANU CH4 switch is set to AUTO and auto adjustment mode is active, the limiter is disabled regardless of these settings.
AUTO LEVEL CH3	Selects the method for setting CH3 level. ON: Engages the auto adjustment mode. (The limiter is not available.) OFF: Locks the level.	
AUTO LEVEL CH4	Selects the method for setting CH4 level. Same setting as AUTO LEVEL CH3. ON, OFF	
25M REC CH SEL	Selects the audio channels to be recorded in the DVCPRO and DV formats. 2CH: Only recorded on CH1 and CH2. 4CH: Records on all four channels.	<ul style="list-style-type: none"> Not available in the following conditions. <ul style="list-style-type: none"> When SYSTEM MODE is 1080-59.94i (50i) or 720-59.94P (50P). When SYSTEM MODE is set to 480-59.94i or 576-50i and REC FORMAT is set to the DVCPRO50 codec. REC SIGNAL is set to 1394 (operation depends on 1394 input status). When compiling to a clip in one-clip recording mode.
TEST TONE	Selects the test signal. LEVEL1: A 1 kHz test tone is output during color bar output. LEVEL2: Outputs the above test tone at a volume lower than LEVEL1. OFF: Does not output a test tone.	

___ indicates the factory setting.

Setup menu list (continued)

AUDIO SETUP screen (continued)

Item	Setting	Notes
INT MIC	Determines whether or not input from the internal microphone is used during recording. ON: Uses internal microphone input. OFF: Does not use internal microphone input.	
MIC GAIN1	Sets the level of an external microphone connected to the AUDIO INPUT1 terminal. – 40dB, <u>50dB</u> , 60dB	
MIC GAIN2	Sets the level of an external microphone connected to the AUDIO INPUT2 terminal. – 40dB, <u>50dB</u> , 60dB	
1394 AUDIO OUT	Selects audio channel output to 1394 OUT in DVCPRO or DV mode. <u>CH1/CH2</u> , CH3/CH4	• Available only when SYSTEM MODE is set to 480-59.94i or 576-50i and REC FORMAT is set to DVCPRO or DV.
AUDIO OUT	Sets the audio signal output from the AUDIO OUT terminal (pin jack), HDMI OUT terminal, headphone terminal, and built-in speaker during P2 card playback. CH1/CH2: CH1 output = CH1 signals, CH2 output = CH2 signals CH1: CH1 output = CH1 signals, CH2 output = CH1 signals CH2: CH1 output = CH2 signals, CH2 output = CH2 signals CH3/CH4: CH1 output = CH3 signals, CH2 output = CH4 signals CH3: CH1 output = CH3 signals, CH2 output = CH3 signals CH4: CH1 output = CH4 signals, CH2 output = CH4 signals	

___ indicates the factory setting.

OUTPUT SEL screen

Item	Setting	Notes
SDI & HDMI SELECT	Sets the type for the signal format output from the SDI OUT and HDMI OUT terminals. 1080i/720P: Follows 1080i, 720P settings of SYSTEM MODE. 1080i*1: Outputs at 1080i even when SYSTEM MODE is set to 720P. DOWNCON: Down converts to SD signal and outputs.	• Not available when SYSTEM MODE is set to 480-59.94i, 576-50i.
SDI & HDMI CHAR	Selects whether or not to superimpose characters on images output from the SDI OUT and HDMI OUT terminals. ON, OFF	
SDI OUT	Selects video output from SDI OUT or HDMI OUT terminal. ON: Video is output from the SDI OUT connector. OFF: Video is not output from the SDI OUT connector.	
SDI METADATA	Sets metadata (UMID) superimposition onto SDI OUT. ON: Superimposes metadata. OFF: Does not superimpose metadata.	
SDI EDH	Sets EDH superimposition when SDI OUT is an SD signal (480i, 576i). ON: Superimposes EDH. OFF: Does not superimpose EDH.	
DOWNCON MODE	Sets downconverter output (VIDEO OUT and DOWNCON SDI OUT) in HD mode (1080i, 720P). SIDE CROP, LETTER BOX, SQUEEZE	• Not available when SYSTEM MODE is set to 480-59.94i, 576-50i.
VIDEO OUT CHAR	Specifies whether or not characters are superimposed on VIDEO OUT signals. ON: Superimposes characters. OFF: Does not superimpose characters.	
VIDEO OUT ZEBRA	Specifies whether or not zebra pattern is superimposed on VIDEO OUT signals. ON: Displays a zebra pattern also on images output via the VIDEO OUT connector. OFF: The zebra pattern is not displayed in video output from the VIDEO OUT connector.	
TC IN/OUT SEL	Selects whether to use the TC IN/OUT terminal for input (TC IN) or output (TC OUT). TC OUT, TC IN	

*1: Use this to check video when SYSTEM MODE is set to 720-59.94P (50P) and 1080i is selected.
___ indicates the factory setting.

Setup menu list (continued)

OUTPUT SEL screen (continued)

Item	Setting	Notes
TC OUT	Sets the time code type output when TC IN/OUT connector is connected as TC OUT. TCG: Outputs the time code generator value of the camera-recorder at all times. TCG/TCR: Outputs time code generator value during camera-recorder recording and outputs the played back time code during video playback.	<ul style="list-style-type: none">• Not available when TC IN/OUT SEL is set to TC IN.
TC VIDEO SYNC	Sets the delay of time code output when TC IN/OUT connector is connected as TC OUT. RECORDING: Outputs the unit's time code with no delay. This is used when performing simultaneous recording on 2 units with this unit's time code as the master. VIDEO OUT: Outputs the time code in line with delay of video output from the VIDEO OUT connector.	<ul style="list-style-type: none">• Not available when TC IN/OUT SEL is set to TC IN.

___ indicates the factory setting.

DISPLAY SETUP screen

Item	Setting	Notes
EVF PEAK LEVEL	Adjusts the peaking level of the viewfinder and the LCD monitor. - 7... <u>0</u> ...+ 7	
EVF PEAK FREQ	Adjusts the peaking frequency of the viewfinder and the LCD monitor. HIGH, LOW	
EVF SETTING	Adjusts viewfinder brightness and contrast on a subscreen. (Subscreen) EVF BRIGHTNESS EVF CONTRAST	
EVF B. LIGHT	Adjusts viewfinder backlight brightness. HIGH, NORMAL, LOW	
EVF COLOR	Selects whether the viewfinder image will be displayed in color or monochrome. ON: Color display OFF: Monochrome display	
EVF MODE	Sets viewfinder off automatically or not when the LCD monitor is opened. AUTO: Switches off automatically. ON: The viewfinder operates constantly. However, this is limited to when no video is output from the SDI OUT terminal. "SDI OUT" (Page 145)	
ZEBRA1 DETECT	Sets the level of the right-leaning zebra pattern 1. 50%...70%...109%	
ZEBRA2 DETECT	Sets the level of the left-leaning zebra pattern 2. 50%...85%...109%	
ZEBRA2	Selects ZEBRA2 type. (Page 66) ON, SPOT, OFF	
MARKER	Turns center marker displayed in the viewfinder and on the LCD monitor on and off. (Page 36) ON, OFF	

___ indicates the factory setting.

Setup menu list (continued)

DISPLAY SETUP screen (continued)

Item	Setting	Notes
SAFETY ZONE	<p>Sets the safety zone displayed in the viewfinder and on the LCD monitor.</p> <ul style="list-style-type: none"> • HD (1080i, 720P) <ul style="list-style-type: none"> <u>90%</u> : 90 % display at 16:9 4 : 3 : 100 % display at 4:3 14 : 9 : 100 % display at 14:9 (between 16:9 and 4:3 size) 1.85 : 1 : 100 % display at 1.85:1 (American VistaVision range) 2 : 1 : 100 % display at 2:1 (Scope Size range) 2.35 : 1 : 100 % display at 2.35:1 (CinemaScope range) 2.39 : 1 : 100 % display at 2.39:1 OFF : Safety zone marker not displayed. • SD (480i, 576i) <ul style="list-style-type: none"> <u>90%</u> : 90 % display at 16:9 4 : 3 : 100 % display at 4:3 13 : 9 : 100 % display at 13:9 14 : 9 : 100 % display at 14:9 OFF : Safety zone marker not displayed. 	<ul style="list-style-type: none"> • When SYSTEM MODE is set to 480-59.94i, 576-50i and ASPECT CONV is set to SIDE CROP or LETTER BOX, the safety zone marker is not displayed even if you select 4:3, 13:9, or 14:9.
FOCUS BAR	<p>The length of the focus bar indicates accuracy of focusing.</p> <p>ON: Displays the focus bar.</p> <p>OFF: Does not display the focus bar.</p>	<ul style="list-style-type: none"> • This function is not interlocked with the FOCUS ASSIST button.
LCD SETTING	<p>Makes it possible to set video color level, brightness and contrast displayed in the LCD monitor in a subscreen. (Subscreen)</p> <p>LCD COLOR LEVEL LCD BRIGHTNESS LCD CONTRAST</p>	
SELF SHOOT	<p>Sets the LCD monitor display when taking self portraits.</p> <p>NORMAL: The LCD image is not inverted sideways.</p> <p>MIRROR: The LCD image is inverted sideways.</p> <ul style="list-style-type: none"> • LCD monitor status displays do not appear when this function is set to MIRROR to shoot self portraits. 	
LCD BACKLIGHT	<p>Adjusts LCD monitor backlight brightness.</p> <p>+1, <u>0</u>, -1, -2, -3</p> <p>+1: The backlight becomes brighter.</p> <p>-3: The darkest setting.</p>	
DATE/TIME	<p>Sets the date and time display.</p> <p>TIME: Hours, minutes and second display</p> <p>DATE: Year, month and day display</p> <p>TIME&DATE: Hours, minutes, seconds and year, month and day display</p> <p>OFF: Not displayed</p>	
LEVEL METER	<p>Sets the Audio Level Meter display.</p> <p>ON, OFF</p>	

___ indicates the factory setting.

DISPLAY SETUP screen (continued)

Item	Setting	Notes
ZOOM-FOCUS	Selects the unit of zoom and focus values. OFF , NUMBER , mm/feet, mm/m <Note> Use the mm/feet or mm/m display only as a general guideline since it is not entirely accurate.	
CARD& BATTERY	Sets the remaining P2 card capacity and battery charge. ON , OFF	
P2CARD REMAIN	Determines how remaining P2 card capacity is displayed. ONE-CARD : Indicates the remaining capacity of the card that is being recorded. TOTAL : Displays value for both cards.	
OTHER DISPLAY	Sets display of other data. PARTIAL : Displays some of the data. ALL : Displays all data. OFF : Not displayed.	
MENU BACK	Select whether to lower the transparency of the background to make menu text easier to read. ON : Lowers background transparency. (However, the transparency of LCD SETTING and EVF SETTING is not lowered.) OFF : Does not lower background transparency.	
REC COUNTER	Selects counter operation during recording. TOTAL : Provides a continuous count until reset by pressing the COUNTER RESET button. CLIP : Clears the count value at start of recording and counts time of recording.	

___ indicates the factory setting.

Setup menu list (continued)

CARD FUNCTIONS screen

Item	Setting	Notes
SCENE FILE	<p>Reads/writes scene files from/onto the SD memory card.</p> <p>FILE SELECT: Selects scene files (1 – 4).</p> <p>READ: Reads the selected scene file (1 – 4) settings stored on the SD memory card.</p> <p>WRITE: Saves the current scene file (1 – 4) settings to the SD memory card.</p> <p>TITLE RELOAD: Reloads title list.</p>	<ul style="list-style-type: none"> • This setting cannot be made when REC SIGNAL is 1394. • Not available when compiling to a clip in one-clip recording mode.
USER FILE	<p>Reads/writes user files (files other than SCENE FILES) from/onto the SD memory card.</p> <p>FILE SELECT: Selects user files (1 – 4).</p> <p>READ: Reads the user file (1 – 4) settings stored on the SD memory card.</p> <p>WRITE: Saves the current user file (1 – 4) settings to the SD memory card.</p> <p>TITLE RELOAD: Reloads title list.</p>	<ul style="list-style-type: none"> • This setting cannot be made when REC SIGNAL is 1394. • Not available when compiling to a clip in one-clip recording mode.
SD CARD FORMAT	<p>Formats SD memory cards.</p>	<ul style="list-style-type: none"> • Not available when compiling to a clip in one-clip recording mode.

OTHER FUNCTIONS screen

Item	Setting	Notes
USER FILE	Saves user files to camera-recorder memory, loads them into camera-recorder memory or initializes them. (Page 60) LOAD, SAVE, INITIAL • This does not affect options in the SCENE FILE screen.	<ul style="list-style-type: none"> • This setting cannot be made when REC SIGNAL is 1394. • Not available when compiling to a clip in one-clip recording mode.
REMOTE	Sets the operations of the supplied remote control unit. "Remote control setup" (Page 24 of Vol. 1) OFF: Operations are not accepted from any remote control. 1: Accepts commands from the remote control set for "operation mode 1". 2: Accepts commands from the remote control set for "operation mode 2".	
1394 CONTROL	Selects the method the camera-recorder uses for controlling external devices connected to the DVCPRO/DV connector. (Page 106) EXT: Controls only the external device, but does not transfer data to the camera-recorder for recording. BOTH: BOTH: Controls both the external device and the camera-recorder, and also records. CHAIN: When there is no more space left for recording in the camera-recorder, recording is automatically made to the external device. OFF: No control	<ul style="list-style-type: none"> • Not available in AVC-Intra mode and DVCPRO HD native mode. • Not available during interval, one-shot and loop recording.
1394 CMD SEL	Determines how recording is stopped when the camera-recorder controls an external device connected to the DVCPRO/DV connector. REC_P: Engages REC/PAUSE status. STOP: Stops recording.	<ul style="list-style-type: none"> • Not available in AVC-Intra mode and DVCPRO HD native mode. • Not available during interval, one-shot and loop recording.
ACCESS LED	Determines whether or not the P2 CARD ACCESS LED should light. ON, OFF	
TALLY LAMP	Sets lighting of the tally lamp. OFF: The tally lamp does not light. FRONT: Front tally lamp (microphone side) lights. REAR: Rear tally lamp (viewfinder side) lights. BOTH: Both tally lamps light.	
CLOCK SETTING	Sets the internal calendar (date). "Setting the calendar" (Page 26 of Vol. 1)	

___ indicates the factory setting.

Setup menu list (continued)

OTHER FUNCTIONS screen (continued)

Item	Setting	Notes																																																																																																												
TIME ZONE	<p>Adds to or deducts from GMT the time value of -12:00 to +13:00 in 30-minute steps. (As an exception, you can set +12:45.) Refer to the table below.</p> <p>0:00</p> <table border="1"> <thead> <tr> <th>Time difference</th> <th>Area</th> <th>Time difference</th> <th>Area</th> </tr> </thead> <tbody> <tr><td>00:00</td><td>Greenwich</td><td>+ 01:00</td><td>Central Europe</td></tr> <tr><td>- 00:30</td><td></td><td>+ 01:30</td><td></td></tr> <tr><td>- 01:00</td><td>Azores Islands</td><td>+ 02:00</td><td>Eastern Europe</td></tr> <tr><td>- 01:30</td><td></td><td>+ 02:30</td><td></td></tr> <tr><td>- 02:00</td><td>Mid-Atlantic</td><td>+ 03:00</td><td>Moscow</td></tr> <tr><td>- 02:30</td><td></td><td>+ 03:30</td><td>Tehran</td></tr> <tr><td>- 03:00</td><td>Buenos Aires</td><td>+ 04:00</td><td>Abu Dhabi</td></tr> <tr><td>- 03:30</td><td>Newfoundland Island</td><td>+ 04:30</td><td>Kabul</td></tr> <tr><td>- 04:00</td><td>Halifax</td><td>+ 05:00</td><td>Islamabad</td></tr> <tr><td>- 04:30</td><td></td><td>+ 05:30</td><td>Bombay</td></tr> <tr><td>- 05:00</td><td>New York</td><td>+ 06:00</td><td>Dacca</td></tr> <tr><td>- 05:30</td><td></td><td>+ 06:30</td><td>Yangon</td></tr> <tr><td>- 06:00</td><td>Chicago</td><td>+ 07:00</td><td>Bangkok</td></tr> <tr><td>- 06:30</td><td></td><td>+ 07:30</td><td></td></tr> <tr><td>- 07:00</td><td>Denver</td><td>+ 08:00</td><td>Beijing</td></tr> <tr><td>- 07:30</td><td></td><td>+ 08:30</td><td></td></tr> <tr><td>- 08:00</td><td>Los Angeles</td><td>+ 09:00</td><td>Tokyo</td></tr> <tr><td>- 08:30</td><td></td><td>+ 09:30</td><td>Darwin</td></tr> <tr><td>- 09:00</td><td>Alaska</td><td>+ 10:00</td><td>Guam</td></tr> <tr><td>- 09:30</td><td>Marquesas Islands</td><td>+ 10:30</td><td>Lord Howe Island</td></tr> <tr><td>- 10:00</td><td>Hawaii</td><td>+ 11:00</td><td>Solomon Islands</td></tr> <tr><td>- 10:30</td><td></td><td>+ 11:30</td><td>Norfolk Island</td></tr> <tr><td>- 11:00</td><td>Midway Island</td><td>+ 12:00</td><td>New Zealand</td></tr> <tr><td>- 11:30</td><td></td><td>+ 12:45</td><td>Chatham Islands</td></tr> <tr><td>- 12:00</td><td>Kwajalein</td><td>+ 13:00</td><td></td></tr> <tr><td>+ 00:30</td><td></td><td></td><td></td></tr> </tbody> </table>	Time difference	Area	Time difference	Area	00:00	Greenwich	+ 01:00	Central Europe	- 00:30		+ 01:30		- 01:00	Azores Islands	+ 02:00	Eastern Europe	- 01:30		+ 02:30		- 02:00	Mid-Atlantic	+ 03:00	Moscow	- 02:30		+ 03:30	Tehran	- 03:00	Buenos Aires	+ 04:00	Abu Dhabi	- 03:30	Newfoundland Island	+ 04:30	Kabul	- 04:00	Halifax	+ 05:00	Islamabad	- 04:30		+ 05:30	Bombay	- 05:00	New York	+ 06:00	Dacca	- 05:30		+ 06:30	Yangon	- 06:00	Chicago	+ 07:00	Bangkok	- 06:30		+ 07:30		- 07:00	Denver	+ 08:00	Beijing	- 07:30		+ 08:30		- 08:00	Los Angeles	+ 09:00	Tokyo	- 08:30		+ 09:30	Darwin	- 09:00	Alaska	+ 10:00	Guam	- 09:30	Marquesas Islands	+ 10:30	Lord Howe Island	- 10:00	Hawaii	+ 11:00	Solomon Islands	- 10:30		+ 11:30	Norfolk Island	- 11:00	Midway Island	+ 12:00	New Zealand	- 11:30		+ 12:45	Chatham Islands	- 12:00	Kwajalein	+ 13:00		+ 00:30				<ul style="list-style-type: none"> This setting cannot be initialized by performing the MENU INIT option and the INITIAL option in USER FILE. After setting the time, change the setting menu TIME ZONE item and the display and the recorded local time will be reset accordingly.
Time difference	Area	Time difference	Area																																																																																																											
00:00	Greenwich	+ 01:00	Central Europe																																																																																																											
- 00:30		+ 01:30																																																																																																												
- 01:00	Azores Islands	+ 02:00	Eastern Europe																																																																																																											
- 01:30		+ 02:30																																																																																																												
- 02:00	Mid-Atlantic	+ 03:00	Moscow																																																																																																											
- 02:30		+ 03:30	Tehran																																																																																																											
- 03:00	Buenos Aires	+ 04:00	Abu Dhabi																																																																																																											
- 03:30	Newfoundland Island	+ 04:30	Kabul																																																																																																											
- 04:00	Halifax	+ 05:00	Islamabad																																																																																																											
- 04:30		+ 05:30	Bombay																																																																																																											
- 05:00	New York	+ 06:00	Dacca																																																																																																											
- 05:30		+ 06:30	Yangon																																																																																																											
- 06:00	Chicago	+ 07:00	Bangkok																																																																																																											
- 06:30		+ 07:30																																																																																																												
- 07:00	Denver	+ 08:00	Beijing																																																																																																											
- 07:30		+ 08:30																																																																																																												
- 08:00	Los Angeles	+ 09:00	Tokyo																																																																																																											
- 08:30		+ 09:30	Darwin																																																																																																											
- 09:00	Alaska	+ 10:00	Guam																																																																																																											
- 09:30	Marquesas Islands	+ 10:30	Lord Howe Island																																																																																																											
- 10:00	Hawaii	+ 11:00	Solomon Islands																																																																																																											
- 10:30		+ 11:30	Norfolk Island																																																																																																											
- 11:00	Midway Island	+ 12:00	New Zealand																																																																																																											
- 11:30		+ 12:45	Chatham Islands																																																																																																											
- 12:00	Kwajalein	+ 13:00																																																																																																												
+ 00:30																																																																																																														
GL PHASE	<p>Selects the output signal whose phase is locked to the signal input to the GENLOCK IN connector in HD (1080i, 720P) mode. (Page 70)</p> <p>HD SDI: The HD SDI is locked to the genlock input.</p> <p>COMPOSITE: The down-converted composite signal (VIDEO OUT or SDI OUT 480i, 576i signal) is locked to the genlock input.</p>	<ul style="list-style-type: none"> Not available when SYSTEM MODE is set to 480-59.94i or 576-50i. 																																																																																																												
H PHASE	<p>Adjusts the horizontal phase when phase is locked to the signal input to the GENLOCK IN connector.</p> <p>- 512...0...+ 511</p>	<ul style="list-style-type: none"> Values change quickly when the Operation lever is held in the ▲ ▼ direction. 																																																																																																												
SEEK SELECT	<p>Selects the position that is cued up when the Operation lever in the ◀ ▶ direction is pressed while playback is paused.</p> <p>CLIP: Start point of clips</p> <p>CLIP&T: Start point of clips and text memo add points</p>																																																																																																													
MENU INIT	<p>Restores all setting menu values including all scene files (F1 to F6) and the user file to their factory defaults.</p>	<ul style="list-style-type: none"> Not available in the following conditions. <ul style="list-style-type: none"> When REC SIGNAL is set to 1394. When compiling to a clip in one-clip recording mode. 																																																																																																												

___ indicates the factory setting.

DIAGNOSTIC screen

Item	Setting	Notes
VERSION	<p>Indicates the version of the firmware used in this camera-recorder. A subscreen provides details on which firmware versions are used. (Subscreen)</p> <p>CAM SOFT: Camera microprocessor software</p> <p>SYSCON SOFT: Software for system control microprocessor</p> <p>P2CS BL2-1: Boot program 1 for P2 control microprocessor</p> <p>P2CS BL2-2: Boot program 2 for P2 control microprocessor</p> <p>P2CS KR: P2 control microprocessor kernel</p> <p>P2CS AP: P2 control microprocessor application</p> <p>VUP: System software used for updating all camera firmware</p> <p>VUP FS: File system for updating the camera</p> <p>CAM FPGA: Camera FPGA configuration ROM</p> <p>DM FPGA: Main FPGA configuration ROM</p>	
MODEL NAME	Indicates the model name of this camera-recorder.	
SERIAL NO.	Indicates serial number of this camera-recorder.	
OPERATION	Indicates the time of the camera-recorder has been on.	

Setup menu list (continued)

OPTION MENU screen

Open this menu by holding down the DISP/MODE CHK button and when shooting status appears press the front MENU button.

- Use this function to check connection status during nonlinear editing.
- Use this function to switch between image production effects.

Item	Setting	Notes
1394 STATUS	<p>Opens the subscreen that shows 1394 status. (Subscreen)</p> <p>FORMAT: Format of input or output signals</p> <p>RATE: Transfer rate of input or output signals</p> <p>60/50: Signal system of input or output signals</p> <p>CH: Channel of input or output signals</p> <p>SPEED: Transfer rate of input or output signals</p> <p>STATUS: Status of signals output or input via the IEEE1394 digital interface</p> <p>VIDEO: Status of input or output video signals</p> <p>AUDIO: Status of input or output audio signals</p>	
1394 CONFIG	<p>Opens a menu for configuring 1394 functionality.</p> <p>DFLT, 1 – 255</p> <ul style="list-style-type: none"> • Use DFLT for normal operation. 	
P.A.P FILTER *1	<p>The type of video filter for improving image quality with 3D processing technology can be selected.</p> <p>TYPE1: This setting is suitable for image production that reduces noise as far as possible with increased sensitivity by using a 3D adaptation effect.</p> <p>TYPE2: This setting suppresses 3D adaptation effects and is suitable for an image production with natural sensitivity and image quality.</p> <ul style="list-style-type: none"> • When a setting is changed, the message "TURN POWER OFF" appears. Then turn the power off and turn it back on again. 	<ul style="list-style-type: none"> • This item cannot be written to or read from an SD memory card as a SCENE FILE or USER FILE.

*1: An image processing circuit for high image quality and high sensitivity using PAP (Progressive Advanced Processing) technology which takes advantage of 3D processing
 __ indicates the factory setting.

Before calling for service

Power supply

There's no power.	<ul style="list-style-type: none"> • Make sure the battery and AC adaptor are connected properly. Check the connections again. 	(Page 21 of Vol. 1)
Power goes off as soon as it is turned on.	<ul style="list-style-type: none"> • The battery may have run out. • If the remaining battery charge display is blinking or <input type="checkbox"/> appears, the battery has run out. • Either recharge the battery or replace the discharged battery with a fully charged one. 	(Page 20 of Vol. 1)

Battery

The battery runs down quickly.	<ul style="list-style-type: none"> • Make sure the battery is fully charged. Keep charging until the AC adaptor's CHARGE lamp goes out. • Are you using the battery in a cold place? The battery is affected by the ambient temperature. Its operating time is reduced in low-temperatures. • The battery may have reached the end of its service life. The battery will become unchargeable. The battery has a certain service life which varies depending on how the battery is used. If the battery operates only for a short period even when it is charged adequately, it has reached the end of its service life. 	(Page 20 of Vol. 1)
The remaining battery capacity is not displayed correctly.	<ul style="list-style-type: none"> • The remaining battery capacity display is merely a guideline. To ensure that remaining battery capacity is displayed correctly, use the battery completely from a fully-charged state, and charge the battery again. (Remaining battery capacity may still not be displayed correctly if the battery has been used for long periods in high or low temperatures, or if the battery has been recharged a large number of times.) 	—

Shooting

Cannot start shooting.	<ul style="list-style-type: none"> • Make sure the POWER/MODE switch is ON. 	(Page 25 of Vol. 1)
Cannot focus automatically.	<ul style="list-style-type: none"> • You can focus automatically when the auto focus mode is selected. • You may be shooting a scene where it is difficult to bring the subject into focus in the auto focus mode. If this is the case, focus in the manual focus mode. It may be hard to bring the subject into focus when <ul style="list-style-type: none"> · both close and distant objects are to be shot · shooting through a dirty window · shooting in a dark place · there are sparkling or shiny objects around the subject · the subject is moving fast · shooting a scene with minimal contrast 	(Page 28)

Before calling for service (continued)

Shooting

<p>Cannot shoot even though the P2 card is inserted correctly.</p>	<ul style="list-style-type: none"> • Make sure the P2 card's write-protect switch is not in the PROTECT position. Recording is not possible if it is in this position. • There may be little free memory left on the P2 card. If so, save the data onto another media, and delete the data you no longer need; alternatively, replace the card with a new one. • The P2 card may be formatted incorrectly. Alternatively, the card you are using may not be formatted for use with the unit. If so, format the card in the unit. • 2 GB P2 cards cannot be used. • The media information display may be indicating " [E] ". If so, format the card in the unit. • Recording is not possible if the number of clips on a single P2 card exceeds 1000. As clips made of many linked clips are generated with one-clip recording, there may be 1000 clips even when the number of clips you can see on the thumbnail screen is less than 1000. 	<p>(Page 12)</p> <p>_____</p> <p>(Page 13)</p> <p>_____</p> <p>(Page 124)</p> <p>_____</p>
<p>Cannot perform interval recording, one-shot recording or loop recording.</p>	<ul style="list-style-type: none"> • Insert 2 cards which recording space are left over 1 minutes when performing loop recording. • In modes such as 24P you cannot perform these types of recording. See page 43 "Using special recording modes" and set the recording format etc. 	<p>(Page 46)</p> <p>_____</p>

Editing

<p>Cannot perform nonlinear editing.</p>	<ul style="list-style-type: none"> • Check the specifications of your personal computer and connecting cable. • Check the menu settings and operation mode. For a 1394 connection, use PB/THUMBNAIL mode or set REC SIGNAL in the setting menu to 1394. Also, for a USB connection, set PC MODE SELECT to USB DEVICE and select PC mode using the POWER/MODE switch. 	<p>(Page 102)</p> <p>(Page 109)</p> <p>(Page 135)</p> <p>(Page 137)</p>
<p>Cannot dub onto an external device.</p>	<ul style="list-style-type: none"> • Make sure the external device is connected correctly. • Are you using a mode that can output from the DVCPRO/DV terminal? You cannot output with native recording mode for AVC-Intra, 24PN etc. 	<p>(Page 103)</p> <p>_____</p>

Displays

<p>Something is wrong with the time code display.</p>	<ul style="list-style-type: none"> • The time code display may not register a regular count if a tape is played in the reverse slow mode. This is normal. 	<p>_____</p>
---	--	--------------

Playback

Cannot play even when I press the play button.	<ul style="list-style-type: none"> • Is the PB/THUMBNAIL lamp on? If the CAMERA lamp is on, press the POWER/MODE switch so that the PB/THUMBNAIL lamp turns on. • Have you selected a clip that cannot be played back (clip number is red)? <ul style="list-style-type: none"> · Clips with a different SYSTEM MODE (1080i, 720P etc.) cannot be played back. · 24-bit audio clips (BITS PER SAMPLE is 24 in AUDIO of CLIP PROPERTY) recorded with devices such as an AJ-HPX3100 cannot be played back. 	(Page 74) (Page 78)
Images do not appear on the television even though I have connected the camera-recorder properly.	<ul style="list-style-type: none"> • Make sure the input selector on your television is set to video input. • Read the television's instructions carefully and select the correct video input connector for the camera-recorder. 	—
Cannot hear any sound from the camera-recorder's speaker.	<ul style="list-style-type: none"> • You may have turned down the camera-recorder's volume control too far. • Adjust the volume level using the PAGE/AUDIO MON/VAR button+. 	(Page 100)
Cannot perform hot swap playback.	<ul style="list-style-type: none"> • This unit does not support hot swap playback. • To replace one card with another during dubbing, stop the dubbing first, and upon completing the replacement, resume it. 	—
Cannot perform clip recording.	<ul style="list-style-type: none"> • Cannot copy when clips are continuously linked in ONE CLIP REC mode. • Select CAMERA mode and push the Operation lever in the ▼ direction (STOP) for 2 seconds to release the clip linking. 	(Page 86)

Other

Cannot read the data on the SD memory card.	<ul style="list-style-type: none"> • Make sure the SD memory card is formatted correctly. • If it is not, format the card in the unit. 	(Page 16)
The remote control does not work.	<ul style="list-style-type: none"> • The battery in the remote control may have run out. • If the remote control fails to work even if it is operated close to the remote control sensor of the camera-recorder, it means that the battery has run out. Replace it with new one. • Make sure the remote control setting is the same for the remote control unit and the camera-recorder. • If the REMOTE setting is different on the remote control and the camera-recorder, the remote control will not work. 	(Page 24 of Vol. 1) (Page 24 of Vol. 1)
There is a rattling sound when the camera-recorder is tilted back and forth.	<ul style="list-style-type: none"> • There are some parts of the camera-recorder that make a rattling sound in the PB/THUMBNAIL mode or when the POWER/MODE switch is OFF. This is normal. 	—
A clicking sound is heard when the power is turned on or when the PB/THUMBNAIL mode is switched to the CAMERA mode.	<ul style="list-style-type: none"> • This initialization operation is performed when the camera-recorder starts up. • It occurs due to the construction of the camera-recorder and is not indicative of any trouble. 	—

Updating the firmware incorporated into the unit

Checking the current version of the firmware using the unit and performing the update

Check firmware version of the camera-recorder in the DIAGNOSTIC screen. Then access the site listed in the NOTE below to check the most recent firmware information and download any firmware you require.

-
- **The update is completed by loading the downloaded file onto the unit via an SD memory card. For details on updating, visit the support desk at the following website.
<http://pro-av.panasonic.net/>**
 - **Be sure to use a compatible SD memory card. The unit is compatible with SD memory cards based on the SD and SDHC standards. Also, be sure to format the memory card using the unit before use.**
-

Cleaning

When cleaning, do not use benzene or thinner.

- Using benzene or paint thinners may deform the camera-recorder and/or cause the surface finish to peel off.
- Before proceeding with maintenance, remove the battery or disconnect the AC cord from the power outlet.
- Use a soft, clean cloth to wipe the camera-recorder. To remove stubborn dirt, wipe the camera-recorder with a cloth moistened with kitchen detergent that has been diluted with water and then use a dry cloth to take up the remaining moisture.

Cleaning the Viewfinder

- If there is dust inside the view finder, remove the eye cup holder and get rid of the dust.
- The interior of the eye cup holder is specially finished, so do not ever wipe it. If there is dust on it, blow it off with an air blower.
- Remove the eye cup holder with the eye cup attached by rotating it counterclockwise. (It will be tightly screwed on.) When you do this, tilt the view finder slightly upward.
- To mount the eye cup holder, align the ridges and grooves of the eye cup holder and camera-recorder, and turn clockwise until the holder clicks into place.

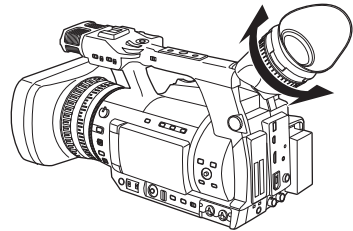
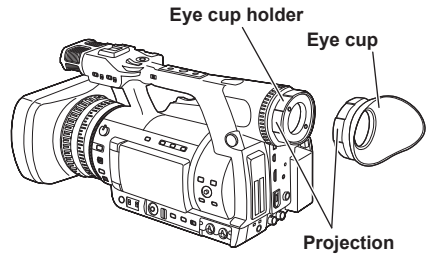

Storage precautions

Before storing the camera-recorder, remove the battery.

Store all of these items in a place with low humidity and relatively constant temperature.

[Recommended temperature range: 15 °C to 25 °C (59 °F to 77 °F)]

[Recommended relative humidity: 40 % to 60 %]

Video camera-recorder

- Wrap the video camera-recorder in a soft cloth to keep the dust off.

Battery

- The battery life is shortened in places with extreme temperatures.
- Storing the battery in a location with oily vapors or high dust concentrations may corrode the terminals or cause other damage, leading to malfunction.
- **Keep metal objects (such as necklaces and hair pins) away from the terminals. Shortcircuiting may occur across the terminals, causing the battery to heat up, and you may seriously burn yourself if you touch the battery in this state.**
- Discharge the battery before storing it. When storing it for an extended time, charge it at least once a year, use up its charge in the camera-recorder, and then store it again.

P2 cards

- After ejecting a P2 card from the unit, be absolutely sure to attach its special cap to keep sand and dust away from the connector area. Stow the P2 cards in their own cases when storing them or carrying them around.
- Do not leave P2 cards in areas where corrosive gases, etc. are present.

SD memory cards

- After ejecting an SD memory card from the unit, be absolutely sure to stow it in its own case.
- Do not leave SD memory cards in areas where corrosive gases, etc. are present.
- Do not leave the cards inside vehicles, in places exposed to direct sunlight or in other places where the temperature is high.
- Do not leave the cards where the humidity level is high or where there are high concentrations of dust.

How to handle data recorded on P2 cards

The P2 card is a semiconductor memory card that is used as the recording medium in the professional video production and broadcasting devices that make up the DVCPRO P2 Series.

- Since data recorded in the DVCPRO P2 format or AVC-Intra are in a file format, they have excellent compatibility with PCs. The file structure is a unique format, which in addition to video and audio data in MXF files contains various other important information items. The folder structure links the data as shown on the right.

Changing or deleting just one information component could make it impossible to recognize the data as P2 data or use the card in a P2 device

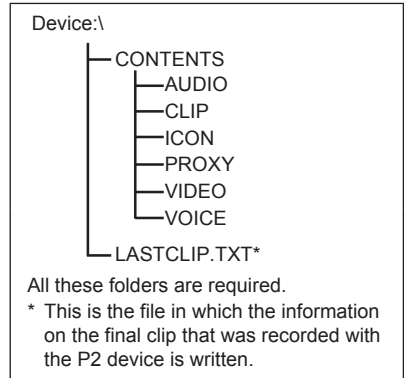

- When transferring data from a P2 card to a PC, or when rewriting data saved on a PC to a P2 card, to prevent data loss be sure to use the special P2 Viewer software. Download it from the following website. You can also visit the support desk at the following website for details on the system requirements of P2 Viewer.

<http://pro-av.panasonic.net/>

- When using regular IT tools such as Microsoft Windows Explorer or Apple Finder to transfer data to a PC, follow the instructions below. However, be sure to use the P2 Viewer when returning data to a P2 card.

- Transfer the corresponding CONTENTS folder and LASTCLIP.TXT file together as a set.
- Do not transfer individual files from the CONTENTS folder.
- When copying, copy the LASTCLIP.TXT file at the same time as the CONTENTS folder.
- When transferring multiple P2 cards to a PC, create a folder for each P2 card to prevent clips with the same name from being overwritten.
- Do not delete data from the P2 card.
- Before using a P2 card, be sure to format it with a P2 device.

Checkpoints for using memory cards

<Cautions in using SD memory cards>

- Use the unit by inserting an SD memory card that is compliant with the SD standard or the SDHC standard.
- MMC (MultiMediaCards) cannot be used. (Bear in mind that taking pictures may no longer be possible if you do use them.)
- If you intend to use miniSD/microSD cards in camera-recorder, always install the adaptor specially designed for miniSD/microSD cards. (The unit will not work properly if only the miniSD/microSD card adaptor is installed. Make sure that the card has been installed in the adaptor before using it.)
- Use of Panasonic's SD memory cards and miniSD/microSD cards is recommended. Be sure to format cards using camera-recorder.
- Any SD memory card with the following capacities (8 MB to 2 GB) and any 32 GB SDHC memory card can be used with the unit.
- For the latest information not available in the operating Instructions, visit the P2 Support Desk at the following Web sites.

<http://pro-av.panasonic.net/>

Cards you can use

- SD memory cards (including miniSD cards)
- SDHC memory cards (including miniSDHC cards)



Cards you cannot use

All memory cards except the ones pictured on the left

- MultiMediaCard



Information on software for this product

1. Included with this product is software licensed under the GNU General Public License (GPL) and GNU Lesser General Public License (LGPL), and users are hereby informed that they have the right to obtain, change and redistribute the source codes of this software.
To obtain the source codes, go to the following home page:
<http://pro-av.panasonic.net/>
The manufacturer asks users to refrain from directing inquiries concerning the source codes they have obtained and other details to its representatives.
2. Included with this product is software which is licensed under MIT-License.

Details on the above software can be found on the installation CD provided with the unit. Refer to the folder called "LDOC".

(Details are given in the original (English language) text.)

Recording format list

SYSTEM MODE	REC FORMAT		Shooting/recording frame mode			
	Codec	Frame mode	VFR OFF	VFR ON		
1080-59.94i	AVC-I100 AVC-I50	60i	60i	1P to 30P ^{*1} (Records as 60i)		
		30PN	30P (30PN native recording)	1P to 30P ^{*1} (30PN native recording)		
		24PN	24P (24PN native recording)	1P to 30P ^{*1} (24PN native recording)		
	DVCPROHD	60i		CAMERA MODE: 60i	1P to 30P ^{*1} (Records as 60i)	
			CAMERA MODE: 30P (2:2 Over60i recording) 24P (2:3 Over60i recording) 24PA (2:3:3:2 Over60i recording)	—		
1080-50i	AVC-I100 AVC-I50	50i	50i	1P to 25P ^{*2} (Records as 50i)		
		25PN	25P (25PN native recording)	1P to 25P ^{*2} (25PN Native recording)		
	DVCPROHD	50i		CAMERA MODE: 50i	1P to 25P ^{*2} (Records as 50i)	
				CAMERA MODE: 25P (2:2 Over50i recording)	—	
720-59.94P	AVC-I100 AVC-I50	60P	60P	1P to 60P ^{*3} (Records as 60P)		
		30PN	30P (30PN native recording)	1P to 60P ^{*3} (30PN Native recording)		
		24PN	24P (24PN native recording)	1P to 60P ^{*3} (24PN Native recording)		
	DVCPROHD	60P		60P	1P to 60P ^{*3} (Over60P recording)	
				30PN	30P (30PN native recording)	1P to 60P ^{*3} (30PN Native recording)
				24PN	24P (24PN native recording)	1P to 60P ^{*3} (24PN Native recording)
720-50P	AVC-I100 AVC-I50	50P	50P	1P to 50P ^{*4} (Records as 50P)		
		25PN	25P (25PN native recording)	1P to 50P ^{*4} (25PN Native recording)		
	DVCPROHD	50P		50P	1P to 50P ^{*4} (Over50P recording)	
				25PN	25P (25PN native recording)	1P to 50P ^{*4} (25PN Native recording)
480-59.94i	DVCPRO50 DVCPRO DV	60i	CAMERA MODE: 60i 30P (2:2 Over60i recording) 24P (2:3 Over60i recording) 24PA (2:3:3:2 Over60i recording)	—		
576-50i	DVCPRO50 DVCPRO DV	50i	CAMERA MODE: 50i 25P (2:2 Over50i recording)	—		

*1: Settable frame numbers are 1, 2, 4, 6, 9, 12, 15, 18, 20, 21, 22, 24, 25, 26, 27, 28, 30P.

*2: Settable frame numbers are 1, 2, 4, 6, 9, 12, 15, 18, 20, 21, 22, 23, 24, 25P.

*3: Settable frame numbers are 1, 2, 4, 6, 9, 12, 15, 18, 20, 21, 22, 24, 25, 26, 27, 28, 30, 32, 34, 36, 40, 44, 48, 54, 60P.

*4: Settable frame numbers are 1, 2, 4, 6, 9, 12, 15, 18, 20, 21, 22, 23, 24, 25, 26, 27, 28, 30, 32, 34, 37, 42, 45, 48, 50P.

Index

Numeric

MENU 25M REC CH SEL	143
MENU 1394 AUDIO OUT	144
MENU 1394 CMD SEL	151
MENU 1394 CONFIG	154
1394 connection	106
MENU 1394 CONTROL	151
MENU 1394 STATUS	154

A

AC adaptor	
Installation	21 of Vol. 1
Removal	21 of Vol. 1
Using	21 of Vol. 1
MENU ACCESS LED	151
Adjusting the volume	
Adjusting the recording level	54
Volume of the sound	100
While shooting	40
MENU AF	140
MENU AGC	140
MENU A.IRIS	140
MENU A. IRIS LEVEL	133
MENU ASPECT CONV	137
ATW	33
MENU ATW	138, 140
Audio equipment	53
Audio input	52
Audio level meter magnification	55
MENU AUDIO OUT	144
MENU AUDIO SETUP screen	143
Auto focus	28
MENU AUTO LEVEL CH3	143
MENU AUTO LEVEL CH4	143
MENU AUTO SW screen	140
Auto tracking white balance	33

B

Battery	
Installation	21 of Vol. 1
Removal	21 of Vol. 1
Using	21 of Vol. 1
Black balance	34
Built-in battery	27 of Vol. 1
Built-in microphone	52

C

MENU CAMERA MODE	136
MENU CARD&BATTERY	149
MENU CARD FUNCTIONS screen	150
Center marker	36
Check recording function	12
MENU CHROMA LEVEL	133
MENU CHROMA PHASE	133

Cine-like gamma	23
Clip	
Copying	86
Deleting	84
Meta data	87
Playing back	79
Property	93
Reconnection	85
Restoring	85

MENU CLOCK SETTING	151
Color bars	40
MENU COLOR TEMP Ach	133
MENU COLOR TEMP Bch	133
Control of external device	106
Counter	61

D

Date and time of shooting	100
MENU DATE/TIME	148
MENU DETAIL CORING	133
MENU DETAIL LEVEL	132
MENU DIAGNOSTIC screen	153
Diopter adjustment	6
MENU DISPLAY SETUP screen	147
MENU DOWNCON MODE	145
MENU DRS	133
MENU DRS EFFECT	133
DVCPRO/DV connector	105

E

Errors	126
MENU EVF B. LIGHT	147
MENU EVF COLOR	147
MENU EVF MODE	147
MENU EVF PEAK FREQ	147
MENU EVF PEAK LEVEL	147
MENU EVF SETTING	147
External microphone	53, 101
Eye cup	23 of Vol. 1

F

Fast-forward	74
FBC	38
Firmware	158
Flash Band Compensation	38
Focus assist	29
Focus bar	29
MENU FOCUS BAR	148
MENU FRAME RATE	132

G

Gain	30
MENU GAMMA	133
GENLOCK	69

Index (continued)

MENU	GL PHASE.....	152
H		
MENU	HANDLE ZOOM	138
	Headphones	101
MENU	HIGH GAIN.....	138
MENU	H PHASE.....	152
I		
	INTERVAL REC.....	44
	Interval recording.....	44
MENU	INTERVAL TIME.....	141
MENU	INT MIC	144
	IRIS button.....	30
	IRIS ring.....	30
K		
MENU	KNEE.....	134
L		
	LAST CLIP DELETE.....	42
MENU	LCD BACKLIGHT	148
	LCD monitor	7
MENU	LCD SETTING.....	148
	Lens hood	
	Attaching	22 of Vol. 1
	Detaching	22 of Vol. 1
MENU	LEVEL METER.....	148
MENU	LIMITER CH1	143
MENU	LIMITER CH2	143
MENU	LIMITER CH3	143
MENU	LIMITER CH4	143
MENU	LOAD/SAVE/INIT.....	132
	LOOP REC	46
	Loop recording.....	46
MENU	LOW GAIN.....	138
M		
	MAIN MENU	30 of Vol. 1
	Manual focusing	28
MENU	MARKER	147
MENU	MASTER PED	133
MENU	MATRIX	134
MENU	MENU BACK	149
MENU	MENU INIT	152
	Meta data	
	Item	88
	Upload.....	87
MENU	MF ASSIST.....	139
MENU	MIC GAIN1	144
MENU	MIC GAIN2	144
MENU	MID GAIN	138
MENU	MODE CHECK	131
MENU	MODEL NAME.....	153
	Monitor.....	104

N		
MENU	NAME EDIT	134
	Native recording	20
	Native VFR recording	21
O		
	ONE CLIP REC	47
MENU	ONE CLIP REC	142
	One-clip recording	47
	ONE SHOT REC	45
	One-shot recording.....	45
MENU	ONE SHOT TIME	141
MENU	OPERATION.....	153
MENU	OPTION MENU screen	154
MENU	OTHER DISPLAY	149
MENU	OTHER FUNCTIONS screen	151
MENU	OUTPUT SEL screen	145
	Overcranking effects.....	26
P		
	P2 card	
	Formatting	13, 91
	Insert	10
	Protecting	12
	Recorded data.....	161
	Recording times	14
	Remove.....	15
	Splitting	14
	Status display.....	131
	Writing data back	116
	P2 card access lamps	12
MENU	P2CARD REMAIN	149
MENU	P.A.P FILTER.....	154
	PB/THUMBNAIL mode	13, 74
MENU	PC MODE SELECT	137
	Phantom microphone	53
	Play.....	74
MENU	PRE REC.....	44
MENU	PREREC MODE	141
	Pre-recording.....	44
	Progressive mode.....	20
	Property	93
	Pull-down recording.....	20
R		
	REC CHECK	12
MENU	REC COUNTER	149
MENU	REC FORMAT	135
MENU	REC FUNCTION	141
	Recording format list.....	164
	Recording mode	43
MENU	RECORDING SETUP screen.....	141
	Recording time codes.....	71
	Recording user bits.....	71

MENU REC SIGNAL	135		
Remaining battery charge	124		
MENU REMOTE	151		
Rewind	74		
S			
MENU SAFETY ZONE	148		
Safety zone marker	36		
MENU SCAN REVERSE	136		
Scene file	56		
MENU SCENE FILE	150		
Scene file data	57		
MENU SCENE FILE screen	132		
MENU SD CARD FORMAT	150		
MENU SDI EDH	145		
MENU SDI & HDMI CHAR	145		
MENU SDI & HDMI SELECT	145		
MENU SDI METADATA	145		
MENU SDI OUT	145		
SD memory card	162		
Formatting	92		
Installation	16		
Removal	16		
Status display	98		
Using	16		
MENU SEEK SELECT	152		
Self-portrait shooting	35		
MENU SELF SHOOT	148		
MENU SERIAL NO	153		
MENU SETUP	137		
Setup menu			
Initializing	29 of Vol. 1		
List	132		
Structure	30 of Vol. 1		
Using	28 of Vol. 1		
Shooting	10, 28		
Shot mark	41, 82		
Shoulder strap	22 of Vol. 1		
SHUTTER	49		
Shutter speed	49		
MENU SKIN TONE DTL	134		
Specifications	32 of Vol. 1		
Standard recording	20		
Standard VFR recording	22		
MENU START DELAY	141		
MENU START TEXT MEMO	142		
MENU SUPER GAIN	138		
MENU SW MODE screen	138		
SYNCHRO SCAN	50		
MENU SYNCHRO SCAN	132		
MENU SYNC SCAN TYPE	132		
MENU SYSTEM MODE	135		
MENU SYSTEM SETUP screen	135		
T			
Tally lamp	9		
MENU TALLY LAMP	151		
MENU TCG	141		
MENU TC IN/OUT SEL	145		
MENU TC MODE	141		
MENU TC OUT	146		
MENU TC PRESET	142		
MENU TC VIDEO SYNC	146		
MENU TEST TONE	143		
Text memo	42		
Thumbnail			
Changing	81		
Selecting	79		
Switching	80		
Thumbnail screen	77		
THUMBNAIL	76		
Time code	61, 66		
Time code display	121		
Time data	61		
MENU TIME STAMP	142		
Time zone	152		
MENU TIME ZONE	152		
Tripod	14 of Vol. 1		
TV	104		
U			
MENU UB MODE	142		
MENU UB PRESET	142		
Undercranking effects	25		
Updating	158		
USB			
Device mode	109		
HOST mode	111		
MENU USER1	139		
MENU USER2	139		
MENU USER3	139		
MENU USER4	139		
User bits	62		
USER button	39		
USER CLIP NAME	90		
MENU USER FILE	150, 151		
MENU USER MAIN	139		
Using the setup menus	28 of Vol. 1		
V			
Variable Frame Rate	21		
MENU V DETAIL FREQ	134		
MENU V DETAIL LEVEL	132		
MENU VERSION	153		
VFR	21		
MENU VFR	132		
MENU VIDEO OUT CHAR	145		

Index (continued)

MENU VIDEO OUT ZEBRA.....	145
Viewfinder	
Status indication.....	120
Using	6

W

Warnings.....	126
Waveform monitor function.....	40
MENU W.BAL.PRESET	138
MENU WFM	139
White balance	
Adjusting	32
Write-protect switch	12

Z

MENU ZEBRA1 DETECT	147
MENU ZEBRA2.....	147
MENU ZEBRA2 DETECT	147
Zebra pattern	35
Zoom	18
MENU ZOOM-FOCUS	149

Panasonic Corporation

Web Site: <http://panasonic.net>

© Panasonic Corporation 2011

Download from [Www.Somanuals.com](http://www.Somanuals.com). All Manuals Search And Download.

Free Manuals Download Website

<http://myh66.com>

<http://usermanuals.us>

<http://www.somanuals.com>

<http://www.4manuals.cc>

<http://www.manual-lib.com>

<http://www.404manual.com>

<http://www.luxmanual.com>

<http://aubethermostatmanual.com>

Golf course search by state

<http://golfingnear.com>

Email search by domain

<http://emailbydomain.com>

Auto manuals search

<http://auto.somanuals.com>

TV manuals search

<http://tv.somanuals.com>