

VL71-FLR **VISLIDER**[®]

Heavy Duty Auto Feeding Screwdriving Tool

Instruction manual (with warranty card)



Table of contents	
Safety precautions	1
Parts designation	1
Specifications	1
Assembling VISLIDER	2
Loading VISROPE	3 - 5
Driving screws	5 - 6
Maintenance and inspection	7

☐ Safety precautions

⚠ WARNING

Denotes risk of personal injury, loss of life or damage to the tool
In case of nonobservance of the instructions in this manual.

- ☐ Before use, be sure to carefully read the instructions. Read the related Drill instruction manual, too.
- ☐ Be sure to wear protective goggles during work.
- ☐ Be sure to wear a dust-proof mask during work.
- ☐ Depending on the work environment, wear ear protectors, hardhat, working shoes, and other safety gear.
- ☐ Be sure to use the specified Adaptor Kit that is dedicated to your Drill model.
- ☐ Be sure to use the specified "VISROPE" connecting screws.
- ☐ Ensure solid footing and hold yourself in a safety-first position.
- ☐ Wear clothes proper for work.
- ☐ Keep the workplace in order and well lit.
- ☐ When working in an elevated place, make sure there is nobody beneath. Be very careful not to let this unit and screws fall.
- ☐ Never direct this unit toward anybody.
- ☐ Never keep your hands, feet and head close to the tip (screw outlet) of the unit during work.
- ☐ Keep the unit away from open fire and flame.
- ☐ Do not use the unit near volatile, flammable substances such as gasoline, thinner, gas, paint, and adhesive. The unit may catch fire or explode.
- ☐ Do not use the unit in rain, or water-splashed, wet or humid area. Do not leave the unit in rain, either.
- ☐ Keep the unit, accessories and consumable parts without reach of children.
- ☐ For after-use handling, refer to "Maintenance and inspection".
- ☐ Handle the unit with enough care. Dropping or hitting may result in malfunction.
- ☐ Keep these instructions in the safe place.

Parts designation

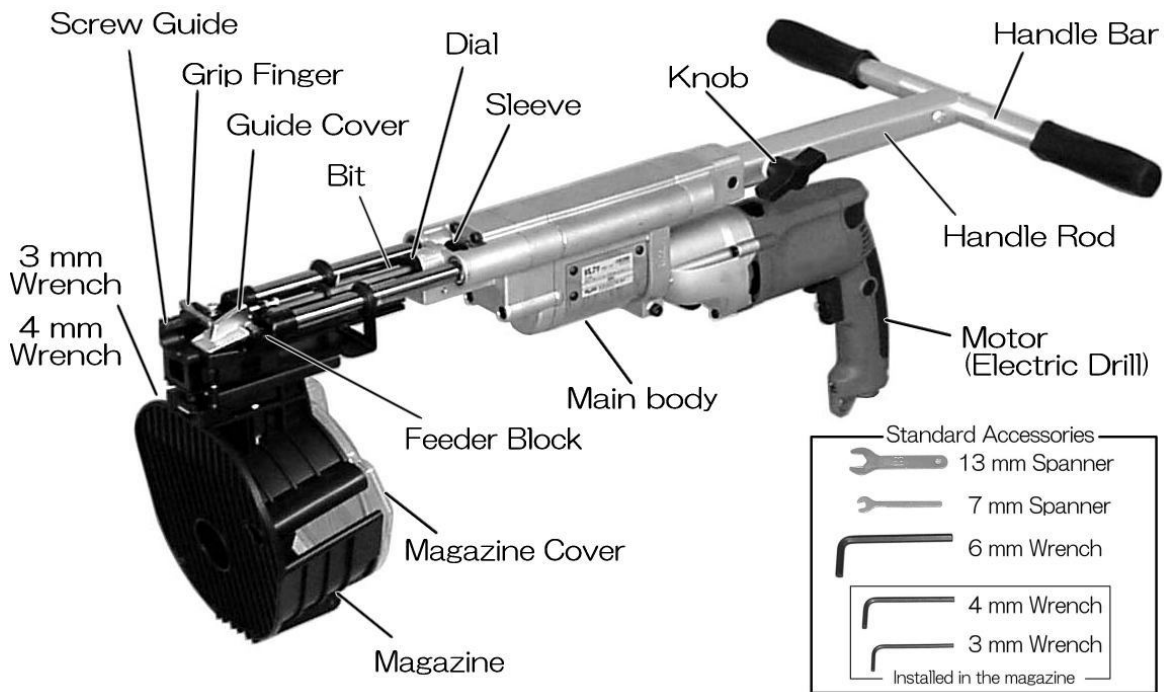

☐ Specifications

Heavy Duty Auto Feeding Screwdriving Tool

Overall length (including the handle)	Approx. 885 -1,005 mm * For 45 mm screw length
Weight (without the motor)	Approx. 5.4 kg
Max. driving depth	Approx. 8 mm
Applicable screw length	32 – 76 mm (1-1/4" to 3")
Applicable screw head diameter	DIA 10 – 13 mm
Applicable screw nominal diameter	DIA 5 – 6 mm
Electrical specifications	See the motor instruction manual

Assembling VISLIDER

1. Assembly and fitting of rod handle

Remove the hexagon fitting bolt and the washer from the handle rod. To the handle rod, fit the handle bar, the washer and the hexagon bolt in this order. Tighten the hexagon fitting bolt using the 13mm spanner.

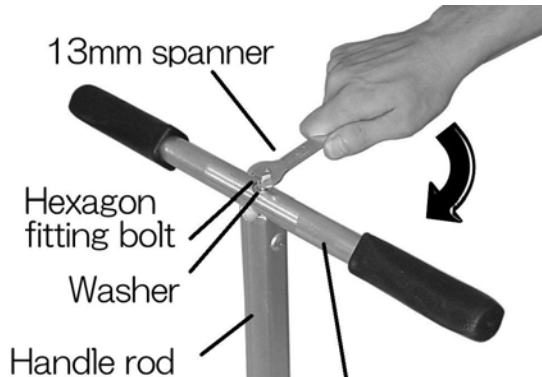

Mount the assembled rod handle on the rear of the main body. Tighten the two fitting screws using the 6mm wrench.

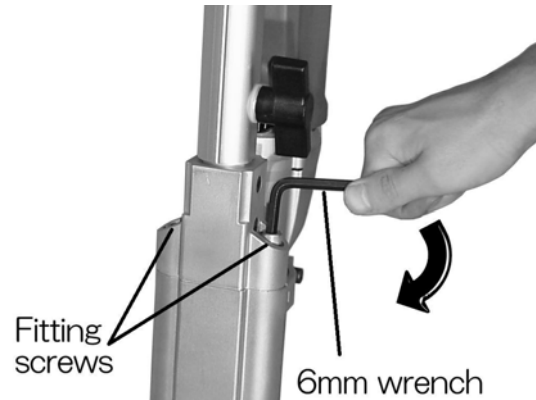

2. Fitting and removal of magazine

To fit the magazine, insert the magazine holder into the bracket at top end of the main body until it clicks.



To remove the magazine, withdraw it while pulling the magazine stopper with fingers.



Loading VISROPE

1. Setting VISROPE

Open the magazine cover while pulling the magazine lever.

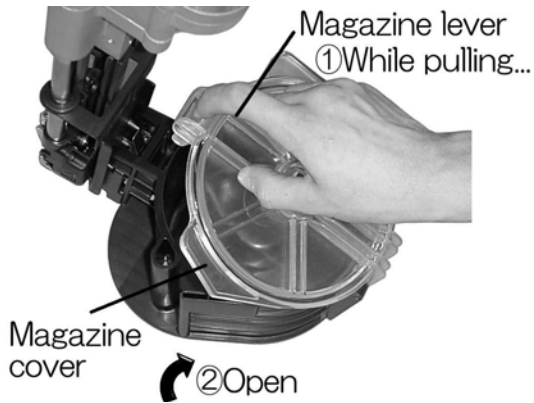

Set the VISROPE to the magazine as shown below. (Remove the rubber band from the VISROPE.)



2. Switching magazine inner lid

Lift the inner lid while holding the inner lid stopper on the magazine cover. Insert the inner lid until it snaps in the orientation corresponding to the screw length.

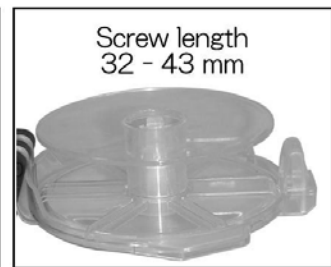
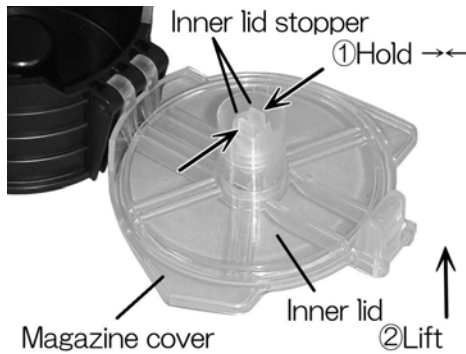

3. VISROPE types and stopper block adjustment

Two types are available in the VISROPE for VL71-FLR, 30mm type and 22mm type. Depending on the type, the position of the guide differs and the stopper block needs to be adjusted to fit for the screws used.

* The first VISROPE has an extended plastic strip as shown below, which is needed to drive the first screw. Please confirm the presence of this extension when loading.

* The stopper block fixing cap screw, when loosened too much, can cause its head to protrude. Pay due attention to it.

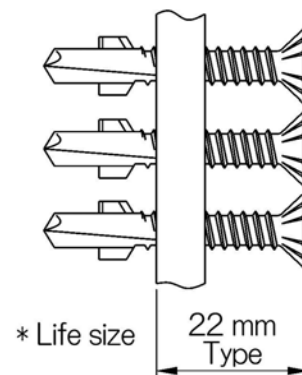
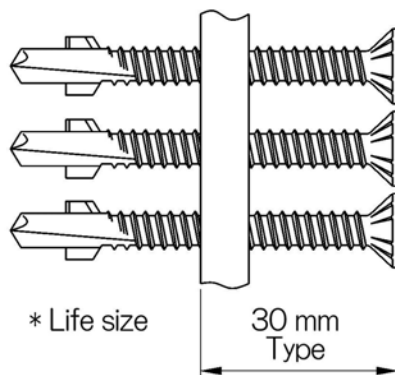

* Factory setting is for 30mm type.

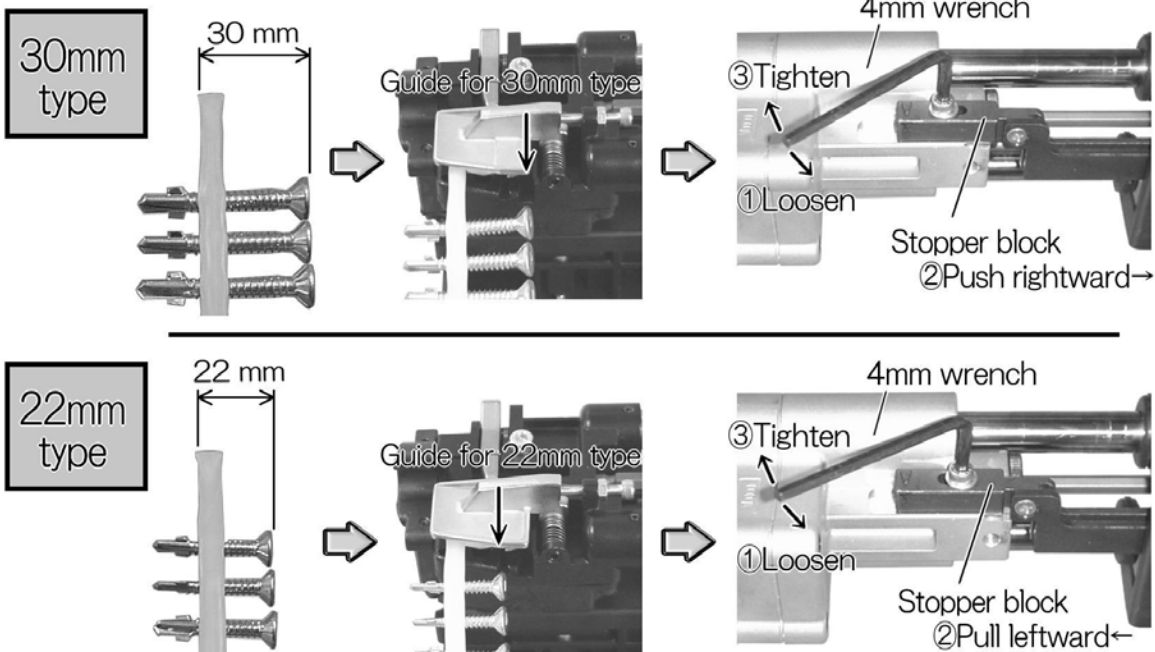

4. Screw guide position adjustment

Carry out the screw guide position adjustment according to the length of the screws used.

* Factory setting is for 45mm screw length.

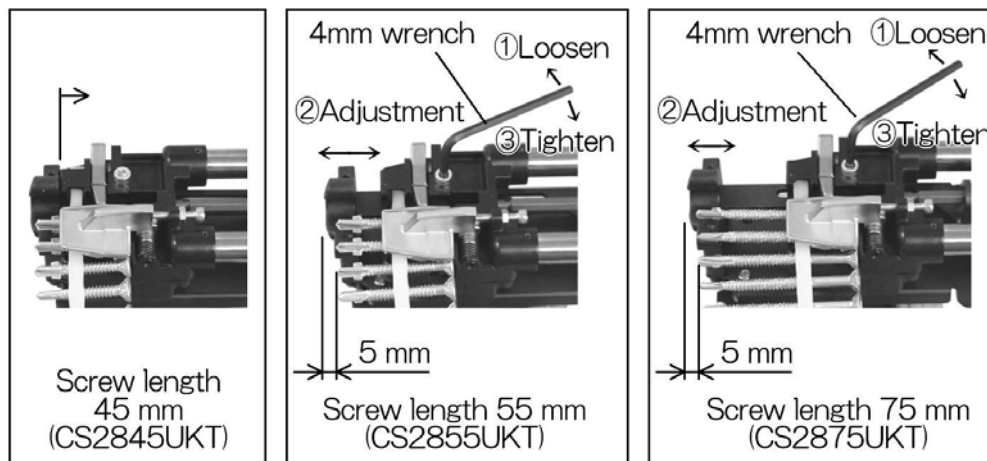

5. Feeding screws

Insert the VISROPE into the feeder block until it stops. Push the main body by no less than 30mm, and then pull it back.

When the screw is not fed to the center even after the above step was repeated several times, carry out the guide cover adjustment by referring to 6. Adjustment of guide cover and then retry the screw feeding.

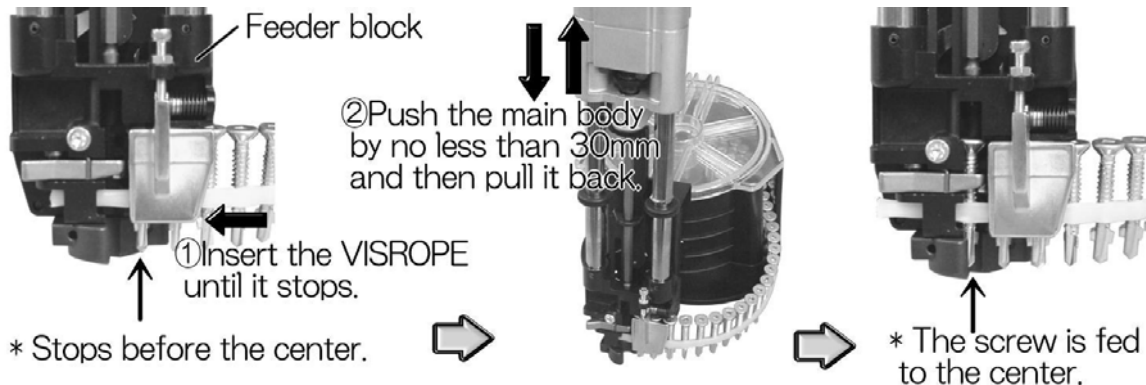

6. Adjustment of guide cover

Improper guide cover play can affect screw feeding or screw driving. Any time the VISROPE was replaced, make sure to check the guide cover play and adjust it to the adequate level.

To adjust the play, first loosen the hexagon nut using the 7mm spanner and then adjust the cap screw using the 3mm wrench. After this, tighten the hexagon nut using the 7mm spanner to fix the cap screw.

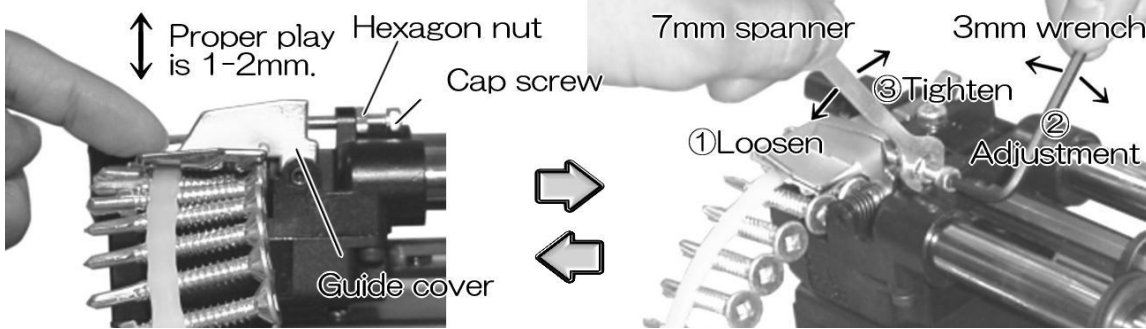

Driving screws

1. Adjustment of rod handle length

To adjust the rod handle length, loosen the knob and press it with force to disengage the inside fixing tab. After this, adjust the length and tighten the knob to fix.

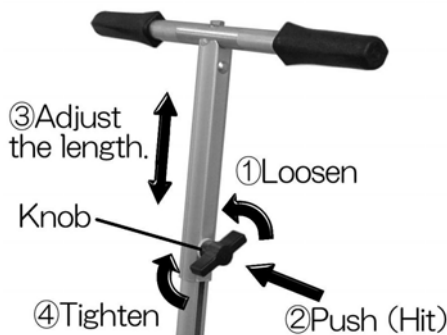

2. Adjustment of screw driving depth

Turn the dial to adjust the screw driving depth.

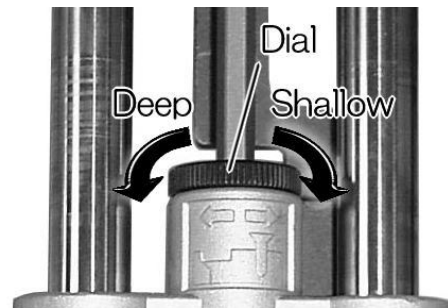

3. Direction of bit rotation

Direction of bit rotation can be reversed using the motor forward/reverse rotation switch. Use the forward (clockwise) rotation to drive (tighten) the screw, and the reverse (counterclockwise) rotation to loosen (remove) the screw.

Refer to the relative instruction manual of the motor on how to operate the forward/reverse rotation switch.

4. Driving screws

First, depress the lock button while pulling the trigger of the motor in order to keep the motor running. Next, hold the handle bar of VL71-FLR and press the tool against the material at the right angle to drive the screw. When the screw has been driven completely to the preset depth, the clutch sound can be heard. Then, reduce the pressing force and pull back the handle bar. The screw driving is now finished and the next screw is made ready at the same time.

* When the screw driving is finished, the sound and vibrations due to clutch contact will be produced. Go on using the tool if there is no problem in screw driving.

* After performing several dozens of VISROPE driving, an empty plastic strip comes out long. Although the machine is usable even if this strip is untreated, cut it with a nipper at a suitable interval lest it should be entangled with the screws outside the magazine and should disturb the operation.

② Press the lock button.



While keeping the motor running ...



Press the tool against the surface at the right angle.

Do not change the angle while driving.

90 degree

5. Removal of VISROPE

To remove the VISROPE, pull out the VISROPE while the guide cover and the grip finger are open.

* Push the main body 5mm or so to facilitate withdrawal of the VISROPE.

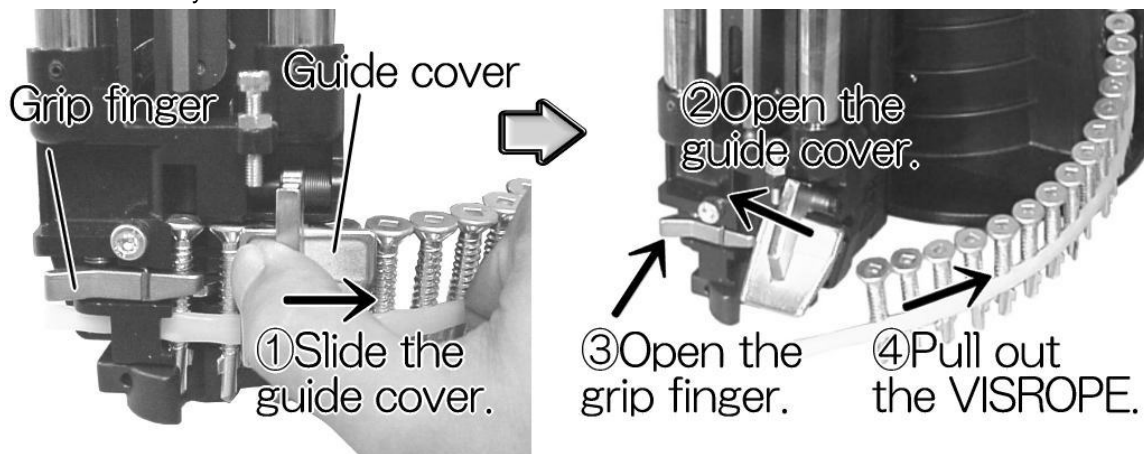

6. Bit replacement

To remove the bit, first pick up the bit as much as possible while pulling the sleeve. Then, while pulling back (pressing down) the top end, pull out the whole bit.

To mount the bit, insert the bit while pulling back (pressing down) the top end. Then, while pulling the sleeve, insert the bit fully to its position and fix it by returning the sleeve. After this, make sure that the bit is fixed completely at its position by moving it up and down.

* The bit is consumable. Worn-out bit may cause poor tightening or damage the screw head. Replace the bit with a new one before it is worn out.

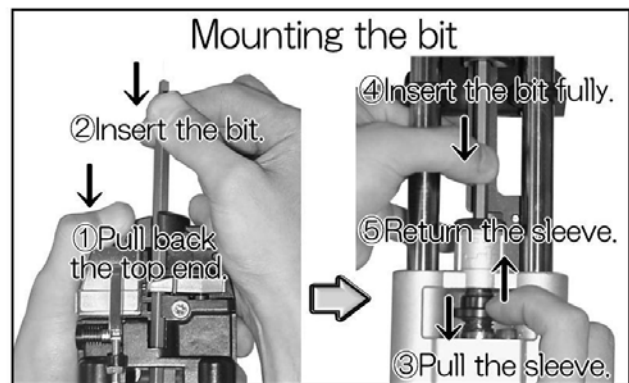
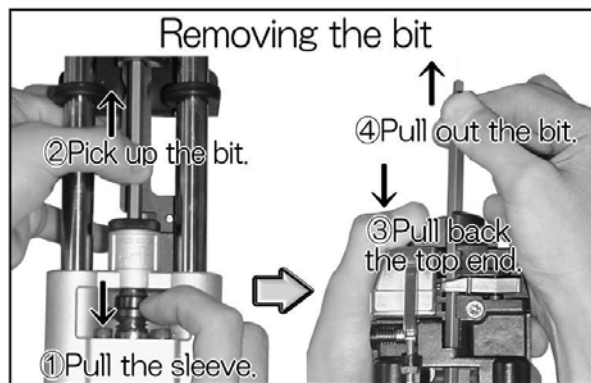

Maintenance and inspection

1. The tool may malfunction if it is used continuously without removing the adhered sawdust, plasterboard particles, iron powder or dusts. Be sure to clean the tool after every use.
2. To wipe the unit clean, use dry cloth or neutral detergent-soaked cloth. Do not use gasoline, thinner or the like, which would damage the unit. Never wash the unit in water, which would get it rusty or malfunctioning.
3. The bit of the specific adaptor kit is consumable. If its both heads have worn out, immediately replace it with new one. Worn-out bit may cause poor tightening or damage the screw head.
4. Store the unit in a dry, cool place. Keep it without reach of children. Avoid any unstable spot to store the unit on.
5. Do not disassemble and repair the unit yourself. For repairs, contact your dealer.

VL71-FLR Warranty Card			
Model	VL71-FLR	Warranty period	6 month after date of purchase
Date of purchase			
Customer	Names		
	Address	Phone	
Dealer	Address		
	Name	Phone	

Make sure that the above form is filled out. This warranty shall be invalid if the *-marked information is missing.

1. If within the warranty period the unit fails due to defect in material or workmanship, the manufacturer will repair the unit free of charge.
2. To ask for free repair within the warranty period, please take the unit and this warranty card with you to your dealer.
3. Even within the warranty period, the following cases are not covered by this warranty.
 - a) Troubles or damages due to wrong handling and use or through tampering with the unit.
 - b) Troubles or damages due to dropping or rough handling during moving or transport.
 - c) Troubles or damages due to fire, earthquake, flood, lightning, and other natural disasters and pollution.
 - d) Troubles or damages due to poor storage and negligence in maintenance.
 - e) Loss or missing of this warranty card.
 - f) No date of purchase, customer's names and address, or dealer's name and address entered in this warranty card. Or forged document.
4. If you want an engineer sent to you for repairing this product, you will be charged for his or her travel expenses and labor.
5. This warranty card will never be reissued. Keep it in a safe place.

This warranty covers free repairs within the written warranty period and under the condition of proper use. This card is not intended to restrict the user's legal rights. For repairs after the warranty period, contact your dealer or the Customers' Services of MURO NORTH AMERICA INC. or MURO CORPORATION.

Manufacturer

MURO CORPORATION

1-4-10 Kaminoge, Setagaya-ku, Tokyo, JAPAN 158-0093
 TEL: +81-03-3703-4122 FAX: +81-03-3704-2348

Please ask to...

MURO NORTH AMERICA INC.

7 Tilbury Crt, Brampton, Ontario, CANADA L6T 3T4
 TEL: (905) 451-7667 FAX: (905) 451-7936
<http://www.muro.com/>

VL71M01U – 2002. 9. 9

Printed in Japan

Free Manuals Download Website

<http://myh66.com>

<http://usermanuals.us>

<http://www.somanuals.com>

<http://www.4manuals.cc>

<http://www.manual-lib.com>

<http://www.404manual.com>

<http://www.luxmanual.com>

<http://aubethermostatmanual.com>

Golf course search by state

<http://golfingnear.com>

Email search by domain

<http://emailbydomain.com>

Auto manuals search

<http://auto.somanuals.com>

TV manuals search

<http://tv.somanuals.com>