

Powered Ditchers

DT55 & DTM55

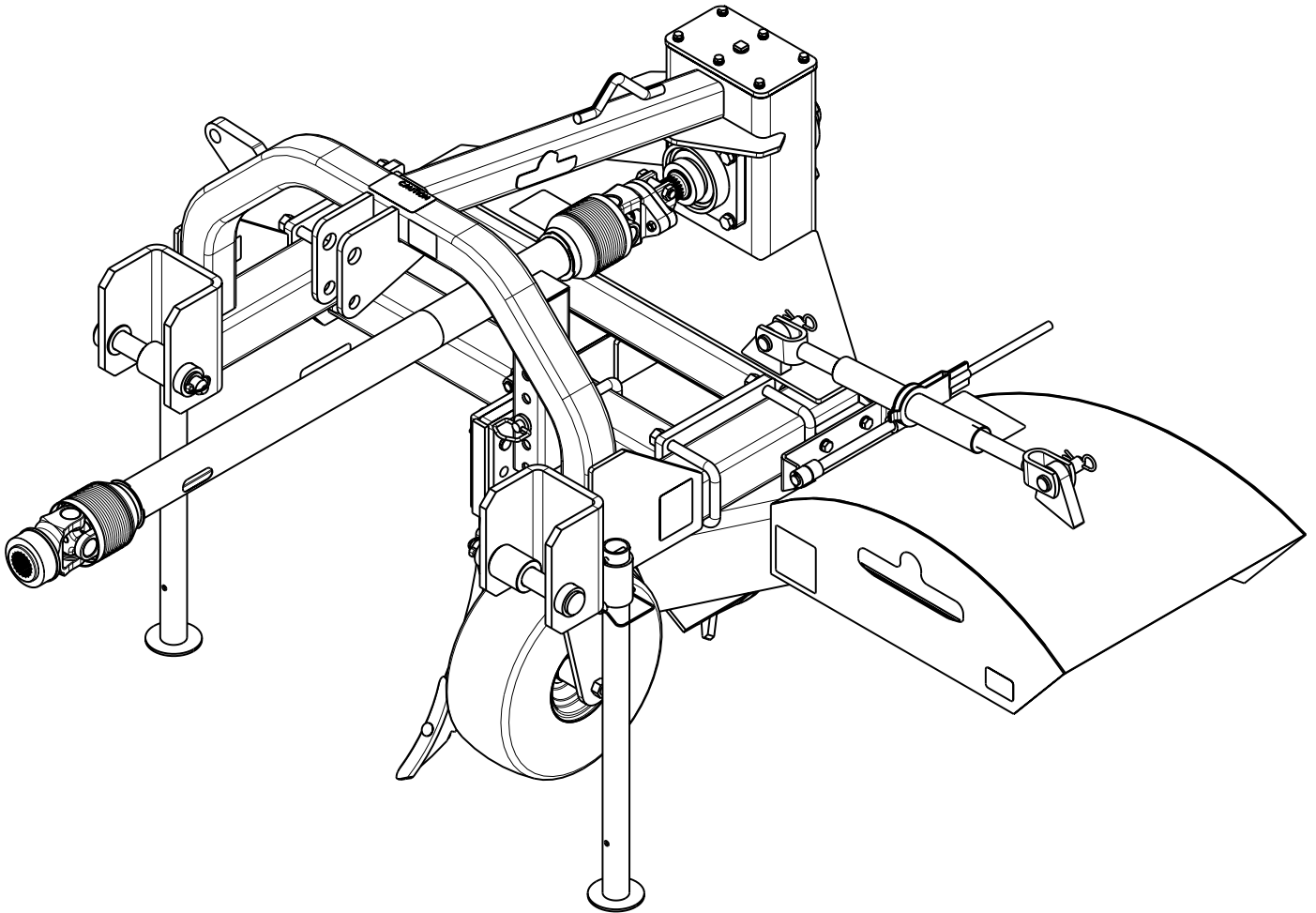

25751

324-053M Operator's Manual



Read the Operator's manual entirely. When you see this symbol, the subsequent instructions and warnings are serious - follow without exception. Your life and the lives of others depend on it!

© Copyright 2008 Printed 3/17/08

Cover photo may show optional equipment not supplied with standard unit.



Important Safety Information	1	Section 3: Adjustments	14
Safety at All Times	1	Drive Chain Adjustment	14
Look For The Safety Alert Symbol	1	Gauge Wheel	14
Safety Labels	4	Manual Chute Adjustment	14
Introduction	7	Hydraulic Chute Adjustment	15
Application	7	Ripper Depth Adjustment	15
Using This Manual	7	Section 4: Maintenance & Lubrication	16
Terminology	7	Maintenance	16
Definitions	7	Storage	16
Owner Assistance	7	Drive Chain Maintenance	16
Serial Number Plate	7	Drive Sprocket and Drive Chain Replacement	17
Further Assistance	7	Lubrication	18
Section 1: Assembly and Set-Up	8	Input Shaft Bearing	18
Tractor Requirements	8	Output Shaft Bearings	18
Tractor Hook-Up	8	Drive Chain	18
Driveline Set-Up	8	Driveline Shafts	19
Checking Driveline Minimum Length	8	Driveline U-Joints (Zerks Both Ends)	19
Driveline Maximum Allowable Length	9	Gauge Wheel Option Bearing	19
Manual Chute Option Assembly	10	Section 5: Specifications & Capacities	20
Hydraulic Chute Option Assembly	10	Section 6: Features & Benefits	21
Ripper Option Assembly	11	Section 7: Troubleshooting	22
Skid Shoe Option Assembly	11	Section 8: Appendix	23
Gauge Wheel Option Assembly	11	Torque Values Chart For Common Bolt Size	23
Section 2: Operating Instructions	12	Notes	24
Transporting	12	Warranty	25
Operating Checklist	12		
Operating Instructions	12		
General Operating Instructions	12		

© Copyright 2008 All rights Reserved

Land Pride provides this publication "as is" without warranty of any kind, either expressed or implied. While every precaution has been taken in the preparation of this manual, Land Pride assumes no responsibility for errors or omissions. Neither is any liability assumed for damages resulting from the use of the information contained herein. Land Pride reserves the right to revise and improve its products as it sees fit. This publication describes the state of this product at the time of its publication, and may not reflect the product in the future.

Land Pride is a registered trademark.

All other brands and product names are trademarks or registered trademarks of their respective holders.

Printed in the United States of America.

Important Safety Information

These are common practices that may or may not be applicable to the products described in this manual.

Safety at All Times

Thoroughly read and understand the instructions given in this manual before operation. Refer to the "Safety Label" section, read all instructions noted on them.

Do not allow anyone to operate this equipment who has not fully read and comprehended this manual and who has not been properly trained in the safe operation of the equipment.

- ▲ Operator should be familiar with all functions of the unit.
- ▲ Operate implement from the driver's seat only.
- ▲ Make sure all guards and shields are in place and secured before operating the implement.
- ▲ Do not leave tractor or implement unattended with engine running.
- ▲ Dismounting from a moving tractor could cause serious injury or death.
- ▲ Do not stand between the tractor and implement during hitching.
- ▲ Keep hands, feet, and clothing away from power-driven parts.
- ▲ Wear snug fitting clothing to avoid entanglement with moving parts.
- ▲ Watch out for wires, trees, etc., when raising implement. Make sure all persons are clear of working area.
- ▲ Turning tractor too tight may cause implement to ride up on wheels. This could result in injury or equipment damage.

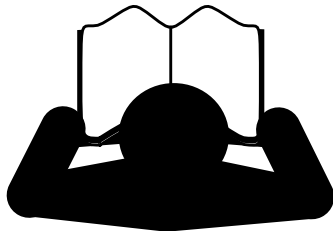

Look For The Safety Alert Symbol

The SAFETY ALERT SYMBOL indicates there is a potential hazard to personal safety involved and extra safety precaution must be taken. When you see this symbol, be alert and carefully read the message that follows it. In addition to design and configuration of equipment, hazard control and accident prevention are dependent upon the awareness, concern, prudence and proper training of personnel involved in the operation, transport, maintenance and storage of equipment.

Be Aware of Signal Words

A Signal word designates a degree or level of hazard seriousness. The signal words are:

DANGER

Indicates an imminently hazardous situation which, if not avoided, will result in death or serious injury. This signal word is limited to the most extreme situations, typically for machine components that, for functional purposes, cannot be guarded.

WARNING

Indicates a potentially hazardous situation which, if not avoided, could result in death or serious injury, and includes hazards that are exposed when guards are removed. It may also be used to alert against unsafe practices.

CAUTION

Indicates a potentially hazardous situation which, if not avoided, may result in minor or moderate injury. It may also be used to alert against unsafe practices.

For Your Protection

- ▲ Thoroughly read and understand the "Safety Label" section, read all instructions noted on them.

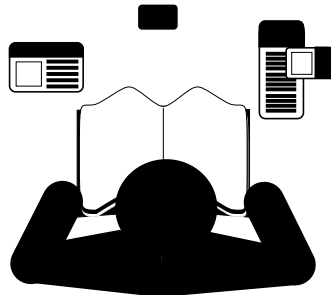

Shutdown and Storage

- ▲ Lower machine to ground, put tractor in park, turn off engine, and remove the key.
- ▲ Detach and store implements in a area where children normally do not play. Secure implement by using blocks and supports.

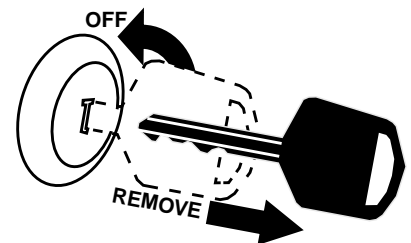

Important Safety Information

These are common practices that may or may not be applicable to the products described in this manual.

Use Safety Lights and Devices

- ▲ Slow moving tractors, self-propelled equipment, and towed implements can create a hazard when driven on public roads. They are difficult to see, especially at night.
- ▲ Flashing warning lights and turn signals are recommended whenever driving on public roads.

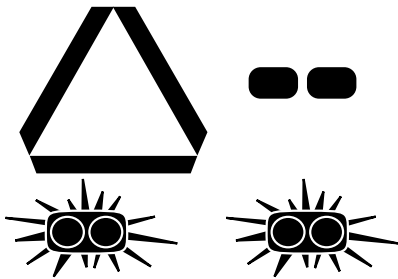

Transport Machinery Safely

- ▲ Comply with state and local laws.
- ▲ Maximum transport speed for implement is 20 mph. **DO NOT EXCEED.** Never travel at a speed which does not allow adequate control of steering and stopping. Some rough terrain require a slower speed.
- ▲ Sudden braking can cause a towed load to swerve and upset. Reduce speed if towed load is not equipped with brakes.

- ▲ Use the following maximum speed - tow load weight ratios as a guideline:
20 mph when weight is less than or equal to the weight of tractor.
10 mph when weight is double the weight of tractor.
IMPORTANT: Do not tow a load that is more than double the weight of tractor.

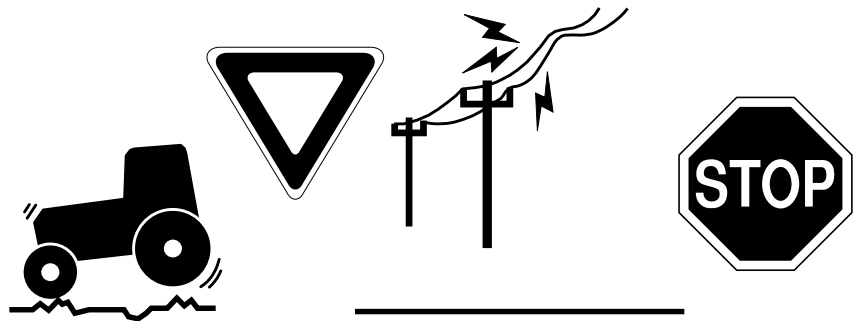

Practice Safe Maintenance

- ▲ Understand procedure before doing work. Use proper tools and equipment, refer to Operator's Manual for additional information.
- ▲ Work in a clean dry area.
- ▲ Lower the implement to the ground, put tractor in park, turn off engine, and remove key before performing maintenance.
- ▲ Allow implement to cool completely.
- ▲ Do not grease or oil implement while it is in operation.
- ▲ Inspect all parts. Make sure parts are in good condition & installed properly.
- ▲ Remove buildup of grease, oil or debris.
- ▲ Remove all tools and unused parts from implement before operation.



Important Safety Information

These are common practices that may or may not be applicable to the products described in this manual.

Prepare for Emergencies

- ▲ Be prepared if a fire starts.
- ▲ Keep a first aid kit and fire extinguisher handy.
- ▲ Keep emergency numbers for doctor, ambulance, hospital and fire department near phone.

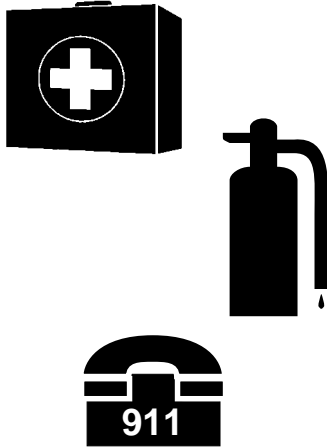
**Wear Protective Equipment**

- ▲ Protective clothing and equipment should be worn.
- ▲ Wear clothing and equipment appropriate for the job. Avoid loose fitting clothing.
- ▲ Prolonged exposure to loud noise can cause hearing impairment or hearing loss. Wear suitable hearing protection such as earmuffs or earplugs.
- ▲ Operating equipment safely requires the full attention of the operator. Avoid wearing radio headphones while operating machinery.

**Avoid High Pressure Fluids Hazard**

- ▲ Escaping fluid under pressure can penetrate the skin causing serious injury.
- ▲ Avoid the hazard by relieving pressure before disconnecting hydraulic lines or performing work on the system.
- ▲ Make sure all hydraulic fluid connections are tight and all hydraulic hoses and lines are in good condition before applying pressure to the system.
- ▲ Use a piece of paper or cardboard, NOT BODY PARTS, to check for suspected leaks.
- ▲ Wear protective gloves and safety glasses or goggles when working with hydraulic systems.
- ▲ If an accident occurs, see a doctor immediately. Any fluid injected into the skin must be treated within a few hours or gangrene may result.

**Keep Riders Off Machinery**

- ▲ Riders obstruct the operator's view, they could be struck by foreign objects or thrown from the machine.
- ▲ Never allow children to operate equipment.

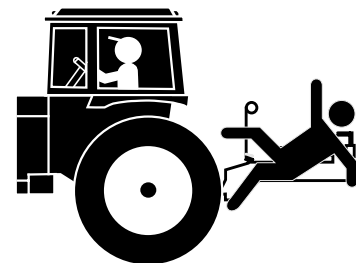

Important Safety Information

Safety Labels

Your Ditcher comes equipped with all safety labels in place. They were designed to help you safely operate your implement. Read and follow their directions.

1. Keep all safety labels clean and legible.
2. Replace all damaged or missing labels. To order new labels go to your nearest Land Pride dealer or visit our dealer locator at landpride.com.
3. Some new equipment installed during repair requires safety labels to be affixed to the replaced component as

specified by Land Pride. When ordering new components make sure the correct safety labels are included in the request.

4. Refer to this section for proper label placement. To install new labels:
 - a. Clean the area the label is to be placed.
 - b. Spray soapy water on the surface where the label is to be placed.
 - c. Peel backing from label. Press firmly onto the surface.
 - d. Squeeze out air bubbles with the edge of a credit card.

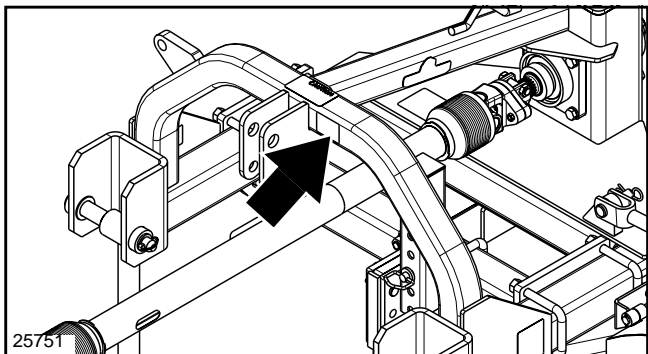

818-130C (DT55)

Caution: 540 RPM

818-240C (DTM55)

Caution: 1000 RPM

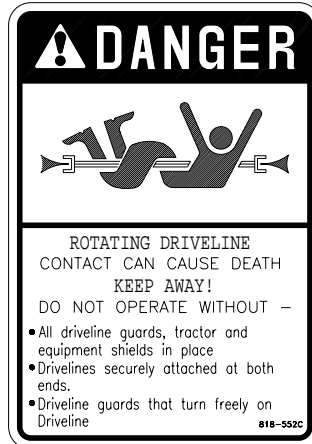
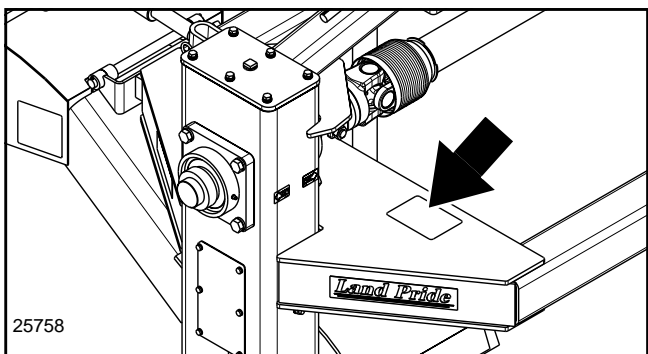

818-552C

Caution: Rotating Driveline

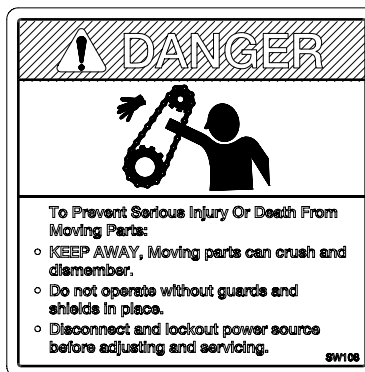
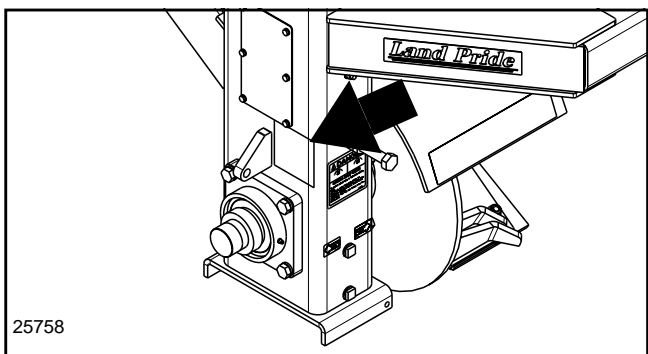

838-111C

Danger: Moving Parts

Important Safety Information

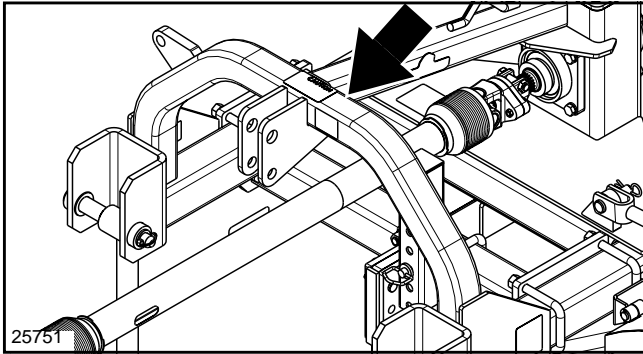

CAUTION

To prevent injury or death:

- Read and understand Operator's Manual before using.
- Lower implement, stop tractor engine, set park brake and remove ignition key before servicing, adjusting, repairing or unplugging.
- Do not allow riders.
- Keep others away during operation.
- Safely support and secure implement before repairs are made. 818-719C

818-719C

Caution: General Instructions

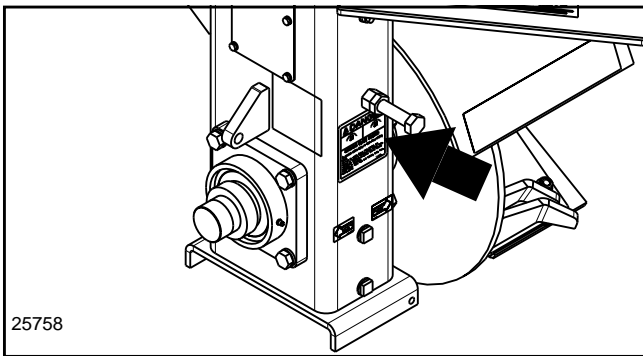

DANGER

ROTATING BLADE HAZARD

To prevent serious injury or death from rotating blades:

- Do not go under frame when blades are turning or engine is running. Keep others away.
- Disconnect and lockout power source before adjusting or servicing.
- Keep hands, feet, hair and clothing away from moving parts.

SW4407

838-295C

Danger: Rotating Blade

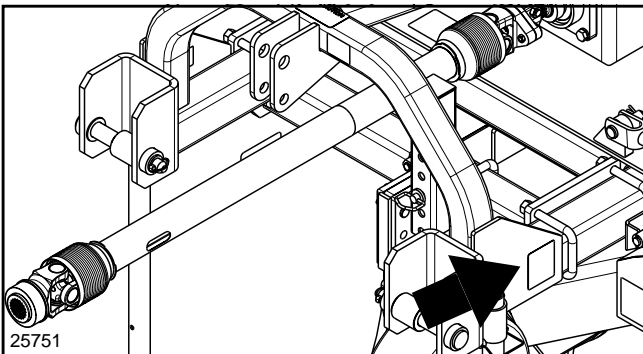

DANGER

THROWN OBJECT HAZARD

To prevent serious injury or death:

- * Do not operate unless all guards are installed and in good condition.
- * Stop blade rotation if bystanders come within several hundred feet.

xxxxx

838-287C

Danger: Thrown Object

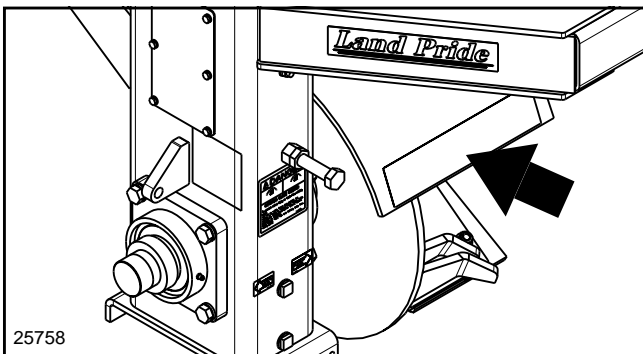

DANGER

838-381C

Danger

Important Safety Information

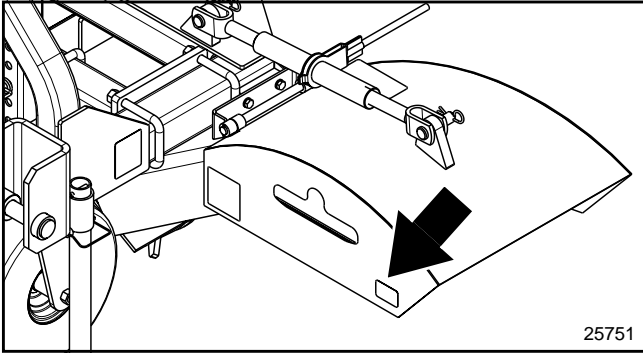

818-229C (Chute Option)
Amber Reflector

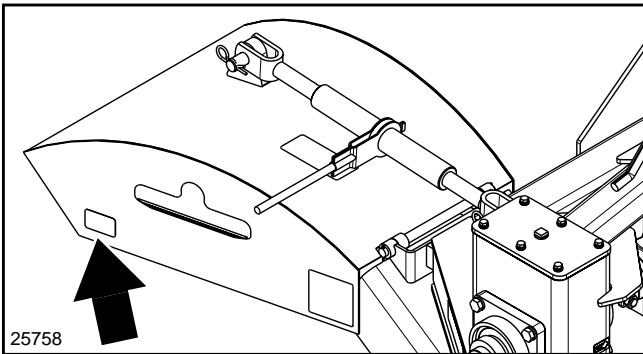

818-230C (Chute Option)
Red Reflector

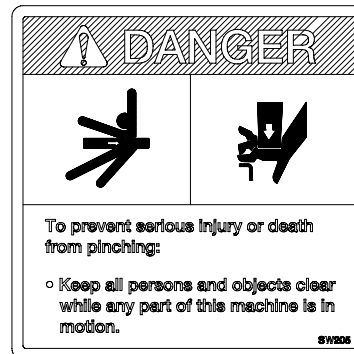
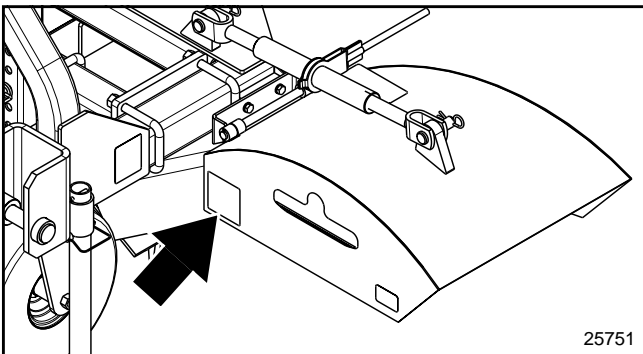

838-112C (Chute Option Both Sides)
Danger: Pinching

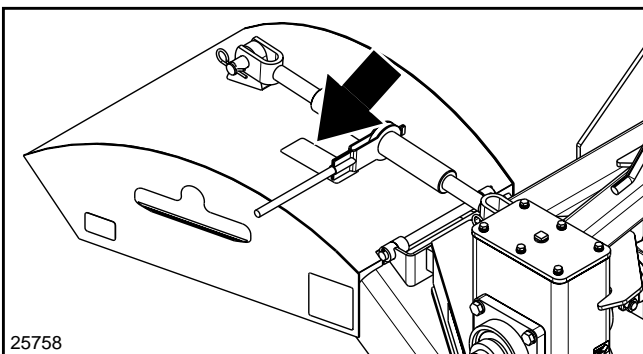

838-094C (Hydraulic Chute Option)
Warning: Hydraulic Pressure

Introduction

Land Pride welcomes you to the growing family of new product owners.

This Ditcher has been designed with care and built by skilled workers using quality materials. Proper assembly, maintenance, and safe operating practices will help you get years of satisfactory use from the Powered Ditcher.

Application

The DT55 Powered Ditcher is a versatile tool to use in many water control applications. Cleaning water ditches along roadsides or in farm fields to drain standing water away from crops, the DT55 makes it simple. The 20" impeller leaves a clean and sculptured trough to keep water flowing freely from unwanted areas. With the optional Material Control Chute in place, dirt can be placed just next to the machine, or thrown many feet away to reshape terraces. An optional ripper, gauge wheel and skid shoe can be attached to aid in reshaping terraces and grader ditches. See **"Features and Benefits"**, **"Section 6"** for additional information.

Using This Manual

- This Operator's Manual is designed to help familiarize you with safety, assembly, operation, adjustments, troubleshooting, and maintenance. Read this manual and follow the recommendations to help ensure safe and efficient operation.
- The information contained within this manual was current at the time of printing. Some parts may change slightly to assure you of the best performance.
- To order a new Operator's or Parts Manual contact your authorized dealer. Manuals can also be downloaded, free-of-charge from our website at www.landpride.com or printed from the Land Pride Service & Support Center by your dealer.

Terminology

"Right" or "Left" as used in this manual is determined by facing the direction the machine will operate while in use unless otherwise stated.

Definitions

NOTE: A special point of information that the operator must be aware of before continuing.

IMPORTANT: A special point of information related to its preceding topic. Land Pride's intention is that this information should be read and noted before continuing.

Owner Assistance

The Warranty Registration card should be filled out by the dealer at the time of purchase. This information is necessary to provide you with quality customer service.

If customer service or repair parts are required contact a Land Pride dealer. A dealer has trained personnel, repair parts and equipment needed to service the Powered Ditcher.

The parts on your Powered Ditcher have been specially designed and should only be replaced with genuine Land Pride parts. Therefore, should your Ditcher require replacement parts go to your Land Pride Dealer.

Serial Number Plate

For prompt service always use the serial number and model number when ordering parts from your Land Pride dealer. Be sure to include your serial and model numbers in correspondence also. Refer to Figure 1 for the location of your serial number plate.

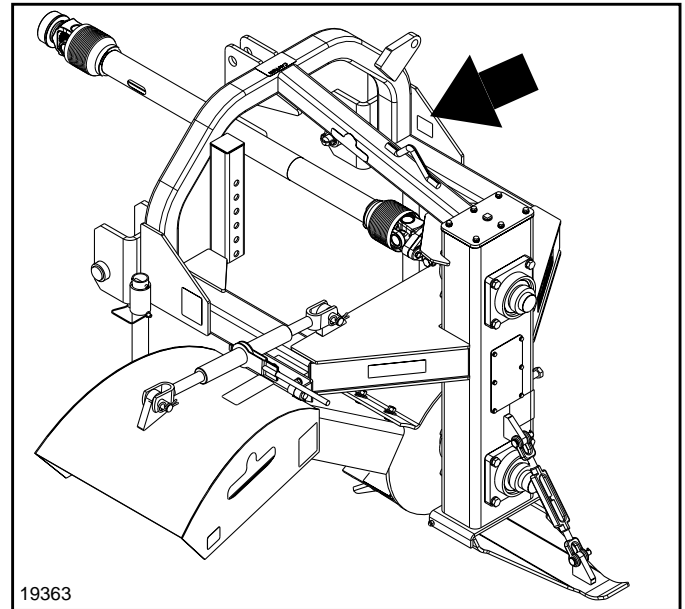

Serial Number Plate Location
Figure 1

Further Assistance

Your dealer wants you to be satisfied with your new Powered Ditcher. If for any reason you do not understand any part of this manual or are not satisfied with the service received, the following actions are suggested:

1. Discuss the matter with your dealership service manager making sure he is aware of any problems you may have and that he has had the opportunity to assist you.
2. If you are still not satisfied, seek out the owner or general manager of the dealership, explain the problem and request assistance.
3. For further assistance write to:

Land Pride Service Department
1525 East North Street
P.O. Box 5060
Salina, Ks. 67402-5060

E-mail address
lp servicedept@landpride.com

Section 1: Assembly and Set-Up

Tractor Requirements

This Powered Ditcher is designed with a Category 2 and 3, 3-point hitch. The maximum horsepower rating for the tractor is 120 HP depending on lift capacity and field conditions. Front tractor weights and/or ballast to tires may be required to offset weight of unit. Consult your tractor manual for details.

CAUTION

Your Ditcher must be mounted only on a tractor equipped with a Category 2 or 3 hitch. **Failure to do so may result in serious injury.**

Tractor Hook-Up

DANGER

Tractor hook-up to equipment is dangerous and can result in serious injury or death. **Do not** allow anyone to stand between the Powered Ditcher and tractor during hook-up operations. **Do not** operate the hydraulic 3-point lift controls while someone is directly behind the tractor or near the implement.

DANGER

Hydraulic fluid under pressure can penetrate skin. Wear protective gloves and safety glasses or goggles when working with hydraulic systems. Use a piece of cardboard or wood rather than hands when searching for hydraulic leaks. If hydraulic fluid is injected into the skin, it must be treated by a doctor within a few hours or gangrene may result.

1. Slowly back tractor up to the Powered Ditcher while using the tractor's 3-point hydraulic control to align the lower hitch link holes with the clevis lug holes on the implement.
2. Engage tractor park brake, shut tractor engine off and remove key before dismounting from tractor.
3. With tractor's lower hitch arms aligned and positioned in the clevises, attach the lower arms to the clevises with hitch pins and secure with lynch pins.
4. Connect top center link to the upper pivot hitch using customer supplied clevis pin and lynch pin.
5. Ensure that the lower hitch arms are blocked to prevent excessive side movement.
6. Return to the tractor and slowly operate the 3-point controls up and down to check for clearance between the implement and tractor. Move or remove the drawbar if it interferes with the Powered Ditcher.
7. Manually adjust one of the two lower lift arms up or down to level the Powered Ditcher from left to right. Manually adjust the length of the top-link to level the Powered Ditcher from front to rear.

Driveline Set-Up

If the Ditcher is to be used on more than one tractor, an additional driveline may be required - especially if a quick hitch is used.

CAUTION

Do not use a PTO adaptor with a quick hitch. A PTO adaptor will increase the strain on the tractor's PTO shaft and can damage the PTO shaft and tiller driveline.

WARNING

Damaged drivelines can cause serious injury or death.

CAUTION

Tractor PTO shield and all Ditcher guards must be in place at all times during operation!

IMPORTANT: Some tractors are equipped with multispeed PTO ranges. Be certain your tractor's PTO is set for the correct PTO speed.

IMPORTANT: Avoid premature driveline breakdown. A driveline that is operating **must not exceed** an angle of 25 degrees up or down while operating the 3-point lift. See Figure 1-1 below.

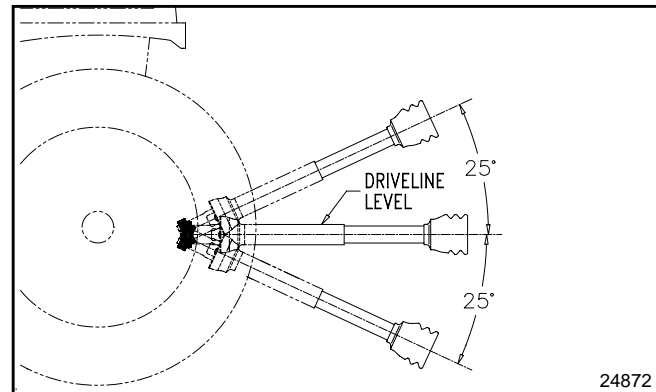

Maximum Allowable Driveline Movement
Figure 1-1

Checking Driveline Minimum Length

IMPORTANT: Always check driveline minimum length and maximum allowable length during initial setup and when connecting to a different tractor. More than one driveline may be required to fit all applications.

Section 1: Assembly and Set-Up

IMPORTANT: It is necessary to align the tractor's PTO shaft level with the Powered Ditcher's drive shaft when checking driveline minimum length. Too long a driveline can damage tractor, driveline and Powered Ditcher.

1. Start tractor and slowly engage tractor's hydraulic 3-point lever to move the lower arms up or down until the driveline shaft is approximately level. Securely block the Powered Ditcher in this position.

Refer to Figure 1-2 on page 9:

2. Place tractor gear selector in park, shut tractor engine off, set park brake and remove switch key.

IMPORTANT: The inner shield half attaches to the Ditcher.

3. Attach driveline to Powered Ditcher and tractor as follows:
 - a. Slide inner universal joint of driveline over the Powered Ditcher's drive shaft and secure with locking collar.
 - b. Slide outer universal joint driveline over the tractor's PTO shaft and secure with locking collar.
 - c. Skip to "Driveline Maximum Allowable Length" if driveline fits.

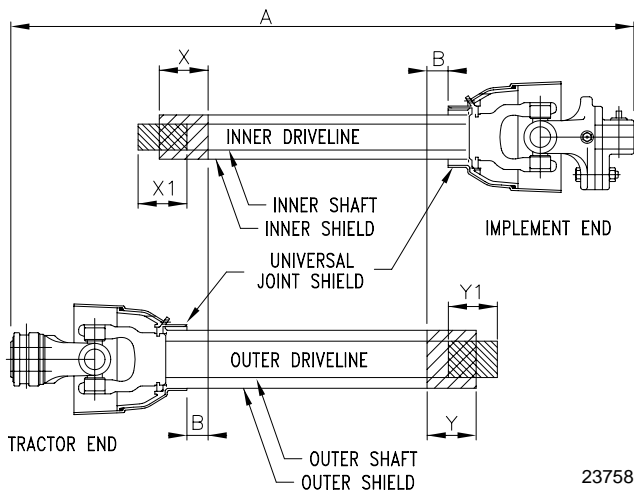

**Driveline Shortening
Figure 1-2**

4. The driveline will require shortening if it is too long to fit between the tractor and Powered Ditcher. Shorten driveline as follows:
 - a. Make sure the Powered Ditcher and tractor PTO shafts are level with each other and the implement is securely supported at this height with support blocks.
 - b. Pull driveline profiles apart into two sections as shown in Figure 1-2.
 - c. Attach outer driveline universal joint to tractor PTO shaft and inner driveline universal joint to

gearbox shaft. Pull on each driveline section to be sure universal joints are secured.

- d. Hold driveline sections parallel to each other to determine if they are too long. The inner and outer shields on each section should end approximately 1" short of reaching the universal joint shield on the adjacent section (see "B" dimension). If they are too long, measure 1" ("B" dimension) back from the universal joint shield and make a mark at this location on the inner and outer shields.
- e. Cut off inner shield at mark ("X" dimension). Cut same amount off inner shaft ("X1" dimension). Repeat cut off procedure ("Y" & "Y1" dimensions) to cut outer driveline half.
- f. Remove all burrs and cuttings.

Driveline Maximum Allowable Length

Be sure to check driveline minimum length before checking driveline maximum allowable length.

Refer to Figure 1-3:

Driveline maximum allowable length, when fully extended, must have a minimum overlap of profile tubes by not less than 1/2 the free length with both inner and outer profile tubes being of equal length.

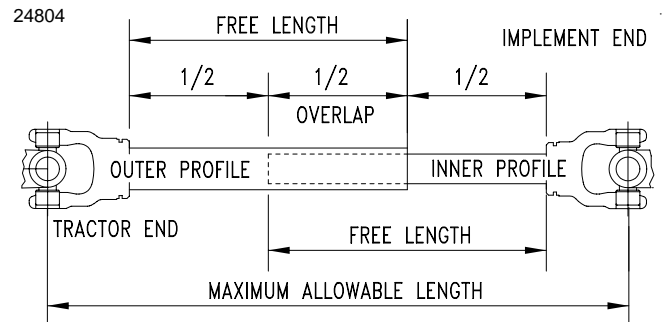

Outer Shielding has been removed for clarity.

**Driveline Maximum Length
Figure 1-3**

1. Pull inner and outer profiles apart. Measure and record free length of both profiles. They should be the same.
2. With driveline profiles pulled apart, apply multi-purpose grease to the inside of the outer profile and reassemble the two profiles.
3. Move driveline halves together until profile tubes overlap by 1/2 the free length. Measure and record maximum allowable length shown in Figure 1-3.
4. Attach inner driveline yoke to drive shaft and outer driveline yoke to tractor's PTO shaft.
5. The driveline should now be moved back and forth to insure that both ends are secured. Reattach any end that is loose.

Section 1: Assembly and Set-Up

IMPORTANT: A small chain is supplied with the driveline. This chain must be attached to the inner driveline shield and to the Powered Ditcher to restrict shield rotation.

6. Hook driveline safety chain in the hole in the inner driveline guard. Attach the other end to the Powered Ditcher's main frame.
7. Start tractor and raise Powered Ditcher just enough to remove support blocks.
8. Slowly engage tractor's 3-point controls to lower Powered Ditcher. Check for sufficient drawbar clearance. Move drawbar ahead, aside or remove if required.
9. Raise and lower implement to find the maximum possible extended driveline length. Check to make certain that the driveline has not extended beyond the maximum allowable length recorded in step 3 on page 9.

Manual Chute Option Assembly

Refer to Figure 1-4:

1. Assemble Chute (#1) to the main frame with hinge pin (#3) and cotter pins (#4). Bend one leg of each cotter pin to keep cotter pin from falling out.
2. Attach ratchet jack (#5) to the chute and frame lugs as shown with clevis pins provided. Secure clevis pins with hair pin cotteners.

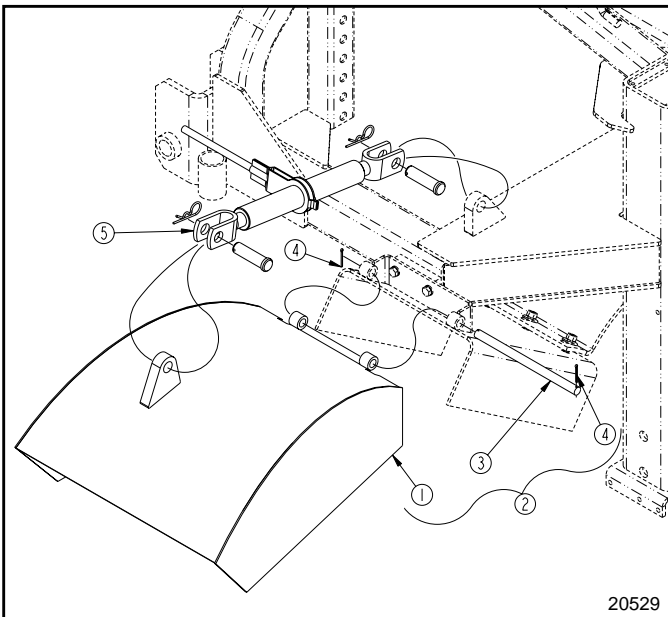

**Manual Chute Option Assembly
Figure 1-4**

Hydraulic Chute Option Assembly

Refer to Figure 1-5:

1. Assemble Chute (#1) to the main frame with hinge pin (#2) and cotter pins (#3). Bend one leg of each cotter pin to keep cotter pin from falling out.
2. Attach hydraulic cylinder to the chute and frame lugs as shown with clevis pins (#4). Secure clevis pins with hair pin cotteners.
3. Route hydraulic hoses through hose guide (#5) as shown.

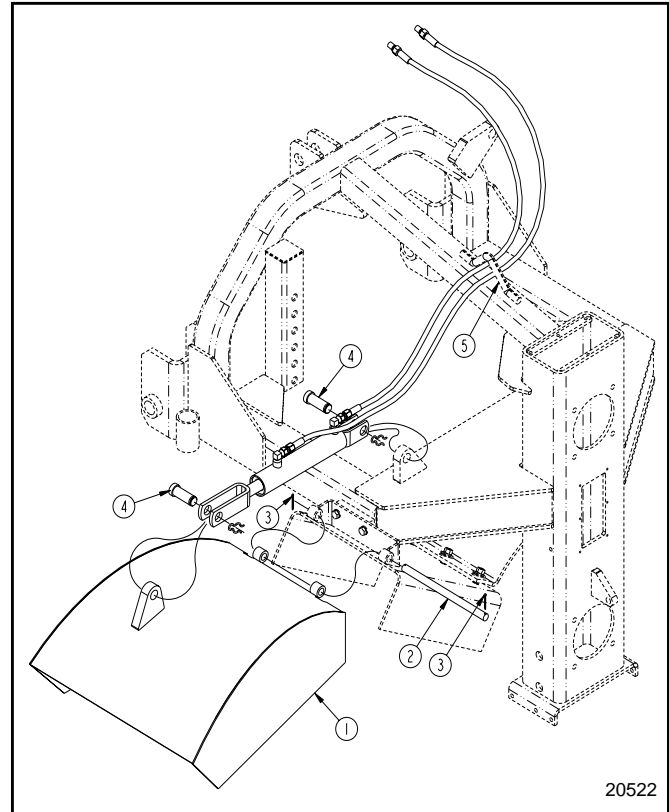

**Hydraulic Chute Option Assembly
Figure 1-5**

Section 1: Assembly and Set-Up

Ripper Option Assembly

Refer to Figure 1-6:

1. Assemble ripper Assembly (#1) to the main frame with four 3/4" u-bolts (#2), lock washers (#3) and 3/4" nuts (#4). Tighten nuts to 170 ft-lbs. of torque.

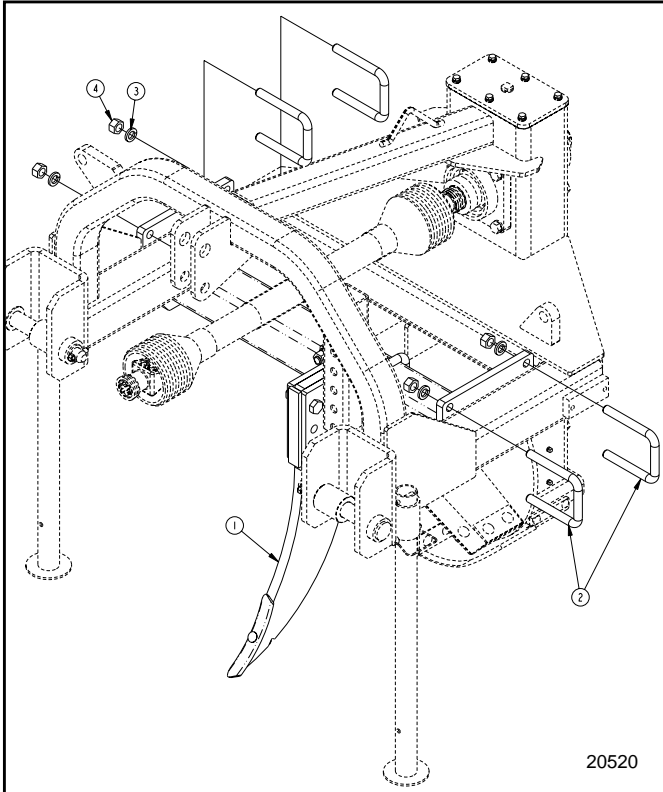

Ripper Option Assembly
Figure 1-6

Skid Shoe Option Assembly

Refer to Figure 1-7:

1. Attach Skid Shoe (#1) to the main frame with 3/8"-16 x 1 1/4" GR5 round head square neck bolts (#2) and lock nuts (#3). Draw lock nuts up snug, do not tighten.
2. Attach one end of turnbuckle (#5) to the main frame lug with clevis pin (#6) and cotter pin (#4).
3. Attach other end of turnbuckle (#5) to the lug on the skid shoe (#1) lug with clevis pin (#6) and cotter pin (#4).
4. Bend one leg of each cotter pin to keep cotter pin from falling out.

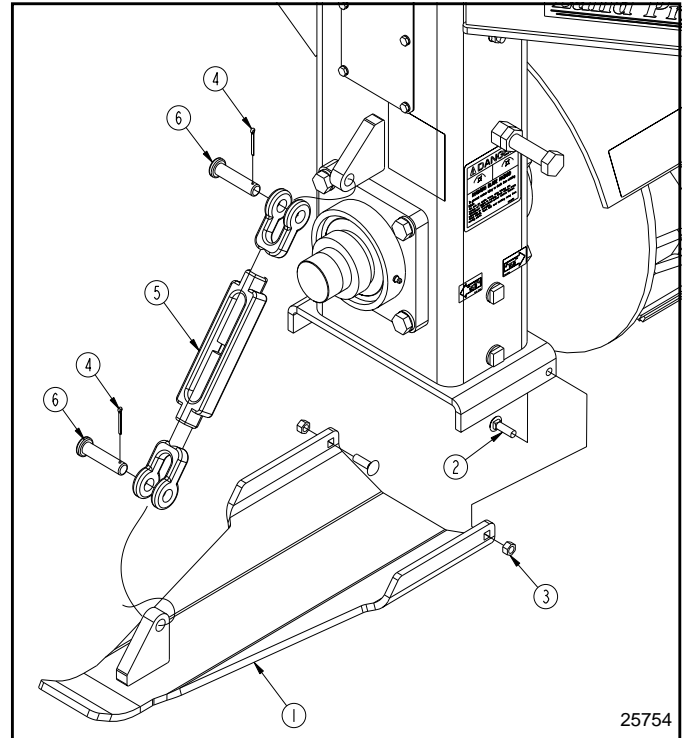

Skid Shoe Option Assembly
Figure 1-7

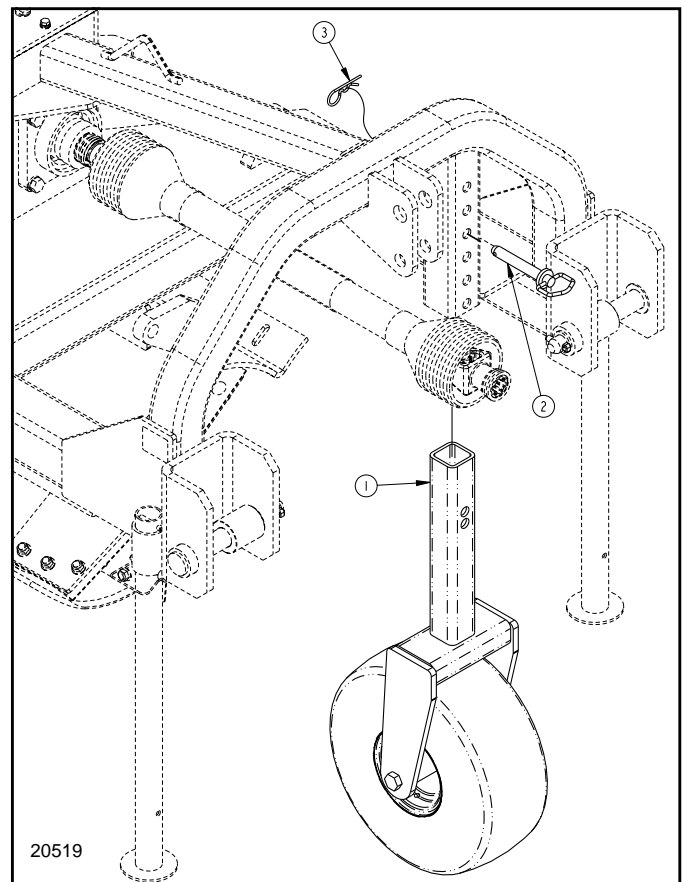

Gauge Wheel Option Assembly
Figure 1-8

Gauge Wheel Option Assembly

Refer to Figure 1-8:

1. Assemble Gauge Wheel Assembly (#1) with hitch pin (#2) and hair pin (#3).

Section 2: Operating Instructions

Transporting

IMPORTANT: ALWAYS disengage PTO before raising the Powered Ditcher to transport position.

1. When raising the Powered Ditcher to the transport position, be sure that the powershaft does not contact tractor or implement.
2. Be sure to reduce tractor ground speed when turning. Leave enough clearance so the Powered Ditcher does not contact obstacles such as buildings, trees or fences.
3. Select a safe ground travel speed when transporting from one area to another. When traveling on roadways, transport in such a way that faster moving vehicles may pass you safely.
4. When traveling over rough or hilly terrain, shift tractor to a lower gear.

 **CAUTION**

When traveling on public roads, whether at night or during the day, use accessory lights and devices for adequate warning to operators of other vehicles. Comply with all federal, state, and local laws.

Operating Checklist

Check	Reference
<input type="checkbox"/> Check chain tension. Refer to "Drive Chain Adjustment".	Section 3 page 14
<input type="checkbox"/> Check oil level in chaincase. Refer to "Lubrication".	Section 4 page 18
<input type="checkbox"/> Check that all plugs have been replaced properly in the chaincase.	Section 4 page 18
<input type="checkbox"/> Check that all bolts and nuts are tight.	Operator's Manual
<input type="checkbox"/> Be certain all guards and shields are in place and secure.	Operator's Manual
<input type="checkbox"/> Grease driveline shaft and all other grease fittings. Refer to "Lubrication".	Section 4 page 18
<input type="checkbox"/> Check air pressure in gauge wheel tire. Refer to Tire Inflation Chart for tire pressure.	Section 8 page 23

Operating Instructions

1. Operate with 540 rpm PTO tractor on the DT55 and 1000 rpm PTO on the DTM55.
2. Engage PTO at approximately 200 RPM and slowly increase to proper PTO RPM.
3. Ditching should not be done in wet conditions as soil will stick to the blades and reduce the digging ability of the Ditcher.
4. **DO NOT** make sharp turns or attempt to back up while Ditcher is in the ground.

5. **DO NOT** engage PTO with machine in the fully raised position.
6. **DO NOT** drop 3 point hitch. Lower the Powered Ditcher slowly to the ground.
7. Ground speed should be between 3 and 5 mph for normal conditions. Under extreme rocky conditions ground speed may have to be reduced for satisfactory performance. In general, the slower the ground speed the better job.
8. Proper operating depth and ground speed are interrelated and performance of the Powered Ditcher will improve with operator experience.
9. Periodically check for foreign objects wrapped around the blades and remove them after disengaging PTO, turning off tractor, and removing ignition key.

General Operating Instructions

Now that you have familiarized yourself with the Operator's Manual, completed the Operator's Checklist and properly attached your Powered Ditcher to your tractor, you are almost ready to begin using your Land Pride 55 Series Powered Ditcher.

It is now time to do a running operational safety check. If at any time during this safety check if you detect a malfunction in either the Powered Ditcher or tractor, shut tractor off immediately, remove switch key, and make necessary repairs or adjustments before continuing on.

Make sure the tractor's park brake is engaged, the tractor's PTO is disengaged, the Powered Ditcher is slightly off of the ground and the power shaft is not in a bind. Start the tractor and then back the tractor throttle off until the engine is at low idle. With the tractor running at an idle speed, make sure if equipped, that the optional hydraulically controlled material deflector chute is operating properly for on the go adjustment with the tractor's hydraulic controls. This is also the time to make sure that the rear hydraulic control arms will lower the Powered Ditcher from transport to working position and back without putting the power shaft into a bind. Again, lift the Powered Ditcher slightly off of the ground and raise the engine rpm slightly. Engage the PTO drive and check to make sure everything is running smoothly. If not, safely shut the tractor down and make the necessary corrections. If everything is in proper working condition, you are ready to move to the work site.

You should inspect the area where you intend to work making sure that there are no obvious debris, large rocks, or other materials that are in your working path. You will also want to make sure that there are no people, animals, pets, valuable property and/or equipment in the immediate vicinity that could be harmed by flying rocks, dirt, or debris once you engage the Powered Ditcher.

Section 2: Operating Instructions

If your unit has an optional depth controlling skid shoe and if you have not already set it to the desired depth, you should set the tractor's park brake, shut tractor engine off, remove switch key and then make that setting.

You are now ready to begin operation. Make sure the unit is lifted just barely off of the ground, raise the tractor engine rpm slightly above idle and engage the PTO. The best ditching performance is usually achieved at forward speeds of approximately 3 to 5 mph, so make the proper gear selection and then raise engine rpm to full PTO speed. Begin forward motion while gently lowering the Powered Ditcher into working position. You will immediately begin to see a generous stream of dirt being rapidly ejected off to the left side.

If you are not using a deflector shield, the dirt will usually be ejected outward and will spread evenly over the ground 20' to 50' out. If you are using a deflector shield to form a berm or terrace, now is the time to make sure your chute is correctly adjusted to achieve the desired results. After you have traveled approximately 50', it is a good idea to lift the Powered Ditcher out of working position or soil contact, safely shut your equipment down, and go back to inspect the results. Then make required adjustments before continuing on.

If your ground conditions are extremely hard, you may find it necessary to employ an optional ripper attachment. If your ground conditions are too wet, you shouldn't run at all until drier conditions prevail.

Remember to look back often. With a little practice you will gain the required experience you need to help you achieve the desired results you expect from your Land Pride 55 Series Powered Ditcher.

When you are done ditching, need to take a break, or just need to make a few adjustments to the Powered Ditcher, always remember to do the following:

- Raise the Powered Ditcher up and out of soil contact
- Reduce the tractor's engine rpm
- Disengage the PTO
- Stop on level ground
- Set the park brake
- Turn off the engine
- Remove the key

See "Features and Benefits" section or "Product Specifications" for additional information and performance enhancing options.

Section 3: Adjustments

CAUTION

BEFORE any adjustments are performed, lower the Ditcher to the ground slowly, stop tractor engine and remove switch key. DO NOT attempt to make adjustments while tractor is running.

NOTE: For correct torque values, refer to "Torque Values Chart For Common Bolt Size" on page 23.

Drive Chain Adjustment

Refer to Figure 3-1:

1. Unbolt and remove inspection cover (#1). Be careful not to damage gasket (#7) while removing the cover.
2. Check roller chain for tightness by pressing on the chain between top and bottom sprockets. Chain should have approximately 1/2" movement.

IMPORTANT: Do Not over tighten drive chain. A tight chain will have high wear.

3. If the chain is loose, loosen jam nut (#5) and turn chain adjusting bolt (#3) until excess chain slack is removed.
4. Tighten jam nut (#5) and recheck chain tension.
5. Replace gasket (#7) if damaged during removal of inspection cover.

IMPORTANT: Loctite is required on all bolts (#4) and silicone is required on gasket (#7) before installation.

6. Attach inspection cover (#1) to the main frame with 1/4"-20 x 5/8" GR5 hex head cap screw (#4) and lock washer (#6). Tighten cap screw to the correct torque.

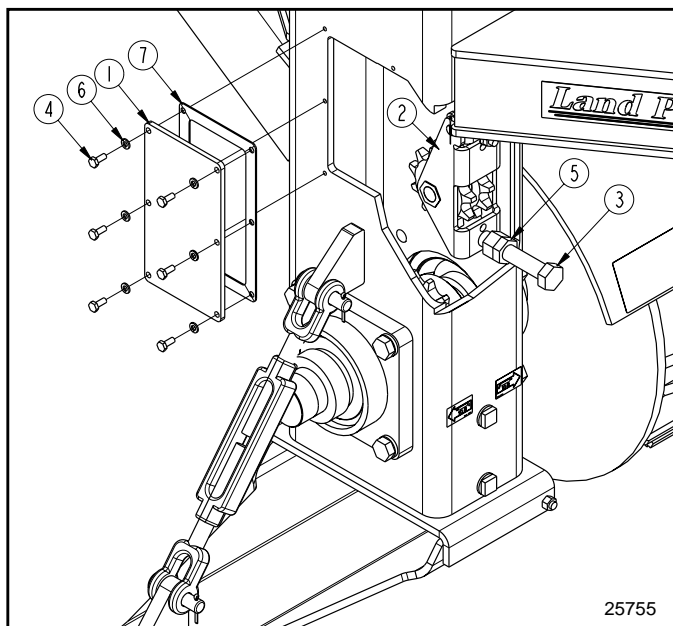

Idler Spring Adjustment
Figure 3-1

Gauge Wheel

Refer to Figure 3-2:

The Gauge Wheel can be adjusted by removing 3/4" hitch pin (#3) and moving gauge wheel (#1) up or down to desired depth. Be sure to secure hitch pin with hair pin cotter (#4) when reinstalling.

Ripper Depth Adjustment

Refer to Figure 3-2:

The Ripper option is designed to tear up hard ground for easier ditching.

Adjust ripper to desired depth by removing pins (#6) and moving the ripper shank (#2) up or down. Replace retaining pins and secure with hair pin cotters (#5).

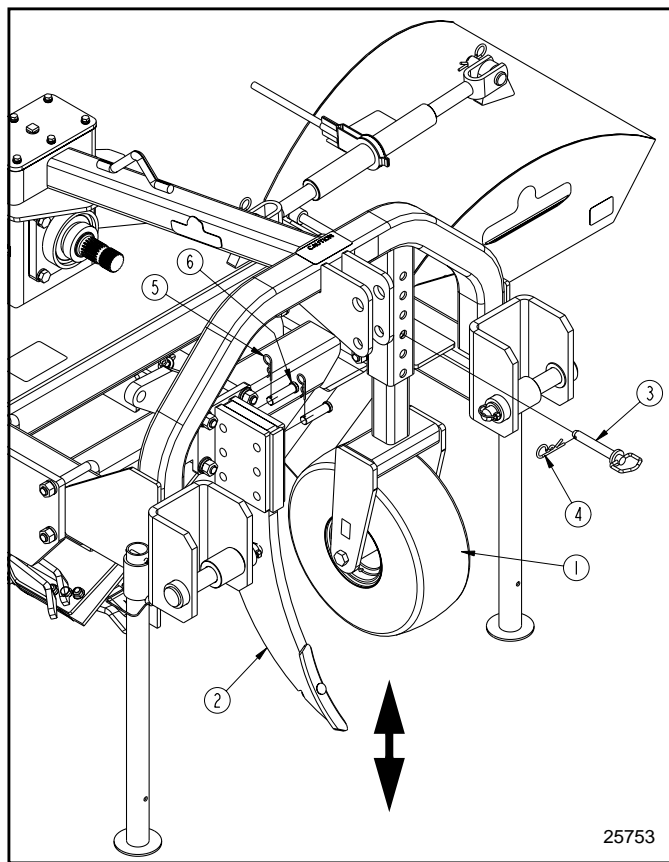

Gauge Wheel Adjustment
Figure 3-2

Section 3: Adjustments

Manual Chute Adjustment

Refer to Figure 3-3:

The Chute controls how far and how high debris will be dispersed. Raise the chute to disperse debris farther and higher. Lower the chute to limit how far and how high debris is dispersed. Raise or lower the chute by setting the ratchet mechanism on the jack and then pumping the jack handle.

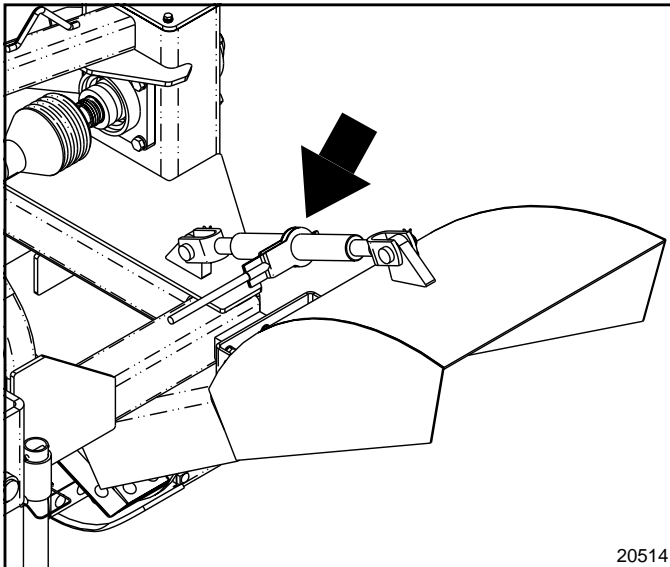

Manual Chute Adjustment
Figure 3-3

Hydraulic Chute Adjustment

CAUTION

BEFORE any adjustments are performed, lower the Ditcher to the ground, stop tractor engine and remove switch key. DO NOT attempt to make adjustments while tractor is running.

Refer to Figure 3-4:

The Chute can be adjusted hydraulically to the desired height by adjusting tractor hydraulics.

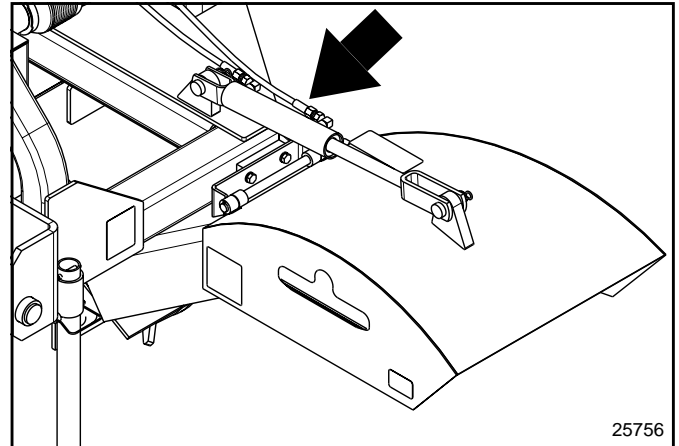

Hydraulic Chute Adjustment
Figure 3-4

Maintenance

Proper servicing and adjustment is the key to the long life of any implement. With careful and systematic inspection, you can avoid costly maintenance, time and repair.



CAUTION

For safety reasons, each maintenance operation must be performed with the Ditcher lowered completely to the ground or folded with the transport boom lock engaged and the tractor engine shut off with ignition key removed.

- After using the Ditcher for several hours, check all bolts to be sure they are tight. For correct torque values, refer to “Torque Values Chart For Common Bolt Size” on page 23.
- Lubricate items as listed under Lubrication, in this section, starting on page 18.
- Replace any worn, damaged or illegible safety labels by obtaining new labels from your Land Pride Dealer. Information about labels is located under Safety Labels in the “**Important Safety Information**” section starting on page 1.

Storage

For short periods, coat all exposed cylinder shafts with grease or a corrosion preventive.

Install dust caps on the quick couplers, if equipped, to prevent dirt contamination of the hydraulic system. Or, if possible, connect the quick couplers together.

At the end of the working season or when the Ditcher will not be used for a long period, it is good practice to clean off any dirt or grease that may have accumulated on the Ditcher and any of the moving parts. It may be necessary to scrape off compacted dirt from the rotor blades, then use a garden hose to thoroughly clean the surface.

Inspect the Ditcher for loose, damaged or worn parts and adjust or replace if needed.

Lubricate as noted in the *Lubrication* portion of this section starting on page 18.

Repaint parts where paint is worn or scratched to prevent rust. Aerosol touch-up paint is available from your Land Pride dealer. Order Land Pride part # 821-002C for Black or #821-011C for beige.

Store Ditcher in a clean, dry place.

Drive Chain Maintenance

The operator should check periodically to make sure that the drive chain is tight. If adjustment is needed refer to “Drive Chain Adjustment” on page 14.

Section 4: Maintenance & Lubrication

Drive Sprocket and Drive Chain Replacement

Refer to Figure 4-1:

1. Remove top cover plate (#1) and rear inspection plate (#2).
2. Loosen jam nut (#14) and idler adjustment bolt (#10).
3. Roll master link (#23) in dual #80 roller chain to top center and remove.
4. Remove chain by pulling chain from the top.

IMPORTANT: Loctite is required on all installed bolts and silicone is required on all installed gaskets.

5. Replace idler sprockets (#22) by removing tightener assembly (#3) from inside the chain case.
 - a. Unscrew 3/8" nuts (#15) and remove tightener assembly (#3).
 - b. Remove cap screw (#9), spacers (#5 & #6) and sprockets (#22). Keep cap screw and spacers for reuse.
 - c. Install new sprockets (#22) by inserting 3/4"-10 x 3 1/2" GR5 hex head cap screw thru idler bracket (#3), spacer (#6), sprocket (#22), sprocket spacer (#5), sprocket (#22), spacer (#6) and out through idler bracket (#3). Secure with lock nut (#13).
 - d. Bolt idler assembly to inside of chain case with existing 3/8"-16 hex flange lock nuts (#15). Tighten 3/8" nuts to the correct torque.
6. Replace drive sprocket (#20) and driven sprocket (#21) as follows:
 - a. Remove lock collars (#31) from rear flange bearings (#29) and front flange bearings (#30).
 - b. Remove 5/8"-11 x 1 1/2" GR5 hex cap screws (#8), lock washers (#18), rear flange bearings (#29) and bearing gaskets (#26).
 - c. Loosen set screws in sprockets (#20 & #21). There are 2 set screws for each sprocket.
 - d. Pull upper drive shaft (#25) and lower impeller shaft (#4) towards front of implement while sliding sprockets (#20 & #21) off the shafts. Be careful not to lose woodruff keys (#7).
 - e. Install new sprockets (#20 & #21) and reassemble by reversing above process.
7. Install new chain from the top by using a pull line or wire to help guide chain around sprockets so you can add master link at top center. Refer to "Drive Chain Adjustment" on page 14 to properly adjust roller chain tension.
8. Install rear inspection plate (#2) and gasket (#27) with lock washer (#16) and 1/4"-2 x 5/8" GR5 hex head cap screws (#11).

9. Install top cover plate (#1) and cover gasket (#28) with galvanized rubber clad washers (#19), lock washers (#17) and 3/8"-16 x 1 1/4" GR5 hex head cap screws (#12). Tighten cap screws to the correct torque.



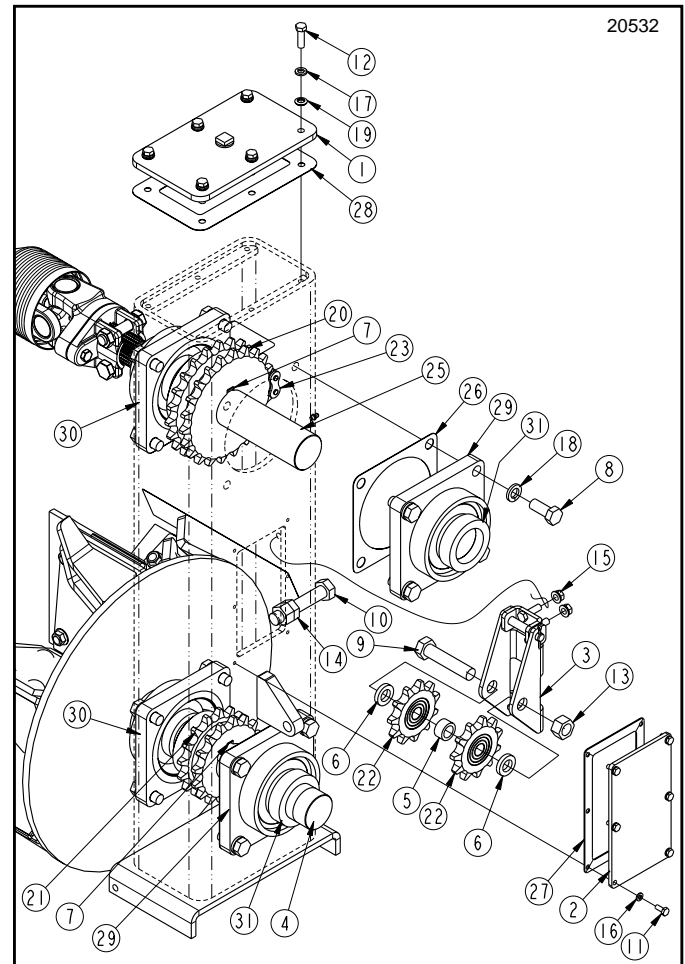

IMPORTANT: Make sure not to forget to install 3/8" galvanized rubber clad washers (#19). If not replaced oil could leak out during operation.





Drive Sprocket and Drive Chain Replacement
Figure 4-1

Section 4: Maintenance & Lubrication

Lubrication

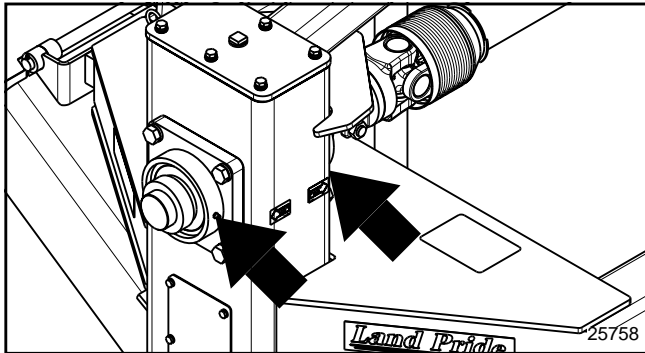
Lubrication Legend	 Multi-purpose spray lube	 Multi-purpose grease lube	 Multi-purpose oil lube	 Intervals in hours at which lubrication is required





	 10 Hours
---	--

Input Shaft Bearing

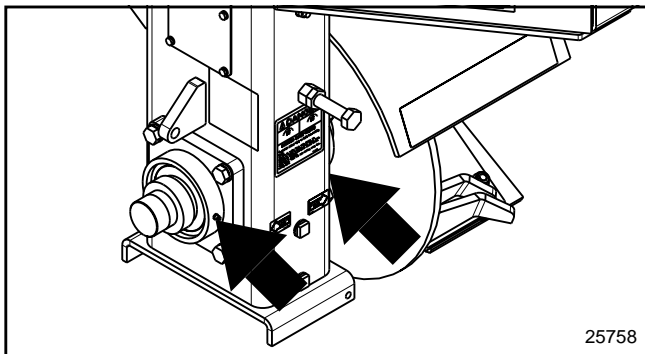
Type of Lubrication: Multi-purpose Grease
Quantity = As required





	 10 Hours
--	---

Output Shaft Bearings

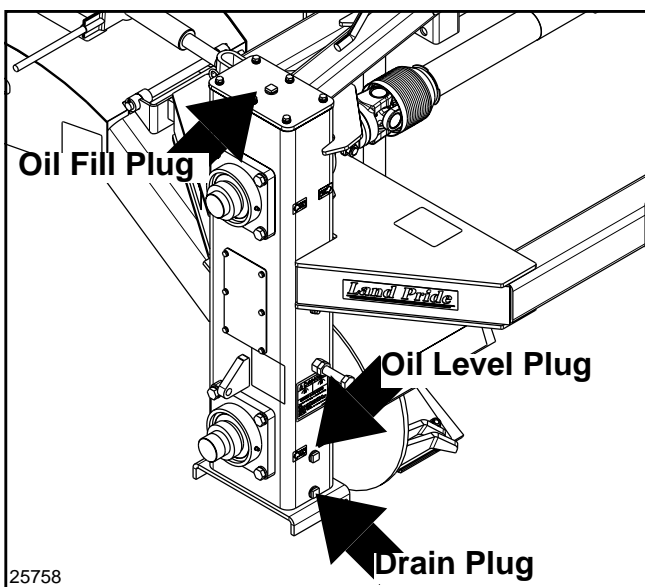
Type of Lubrication: Multi-purpose Grease
Quantity = As required



	 As Required
---	---

Drive Chain

Oil should escape from Oil Level plug hole in chain case when the level plug is removed.

If oil is needed, remove top fill plug and add oil until it escapes from Oil level plug hole.

Type of Lubrication: Shell Alvania EP00 Gear Lube
Land Pride Part #821-045C (32 oz. bottle)

Section 4: Maintenance & Lubrication

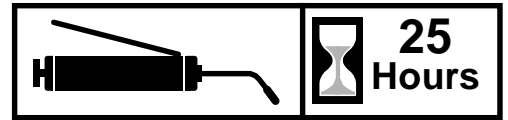
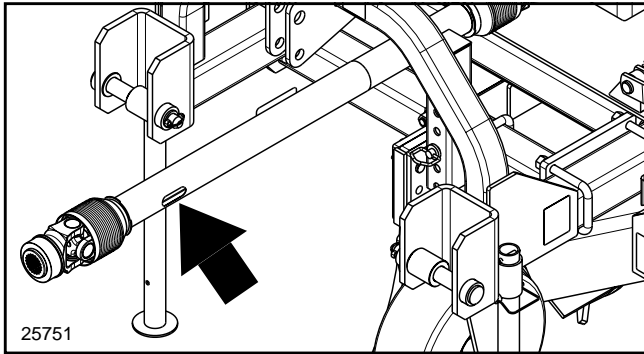

Driveline Shafts

Type of Lubrication: Multi-purpose Grease
Quantity = As required

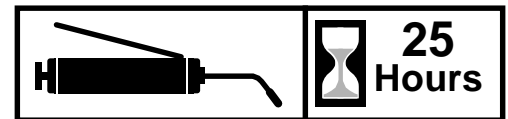
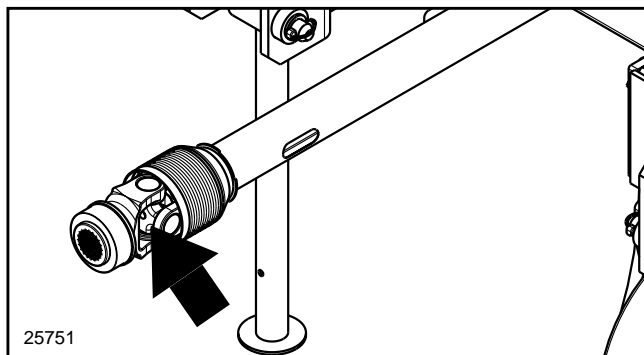

Driveline U-Joints (Zerks Both Ends)

Type of Lubrication: Multi-purpose Grease
Quantity = As required

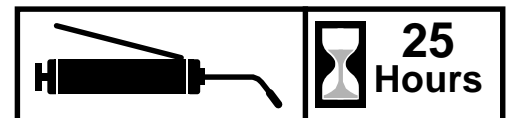
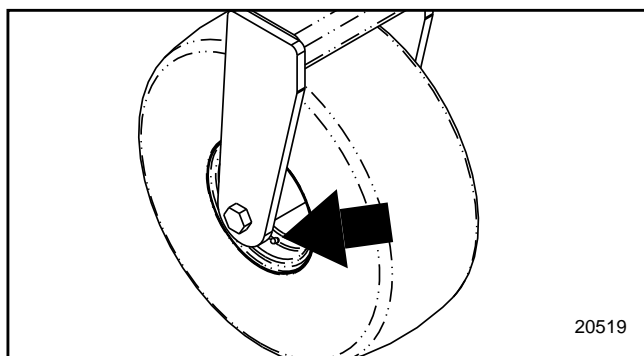

Gauge Wheel Option Bearing

Type of Lubrication: Multi-purpose Grease
Quantity = As required



DT(M)55 Series Powered Ditcher		
	DT55	DTM55
Tractor PTO	540 RPM	1000 RPM
Hitch	Category 2 & Category 3, Quick Hitch Adaptable	
Horse Power Range	70 - 120 HP	
Machine Weight (Without Options)	900 lbs.	850 lbs.
Impeller	20" Impeller	
Impeller Blades	6 ea., 3/8" thick steel with replaceable hardened cutting edges	
Chain	Double 80 chain with positive tension bolt	
Chain Case Oil	Shell Alvania EP 00 Gear Lube Land Pride Part #821-045C (32 oz. bottle)	
Input/Output Shafts	2 1/4" ID ball type bearings	
Driveline	Cat. 5 with shear-bolt	
Material Control Chute (Optional)	Manual or with 2" X 8" hydraulic cylinder and hoses	
Depth Control Wheel (Optional)	16.5 X 6.50-8 pneumatic tire Adjustable from cutting edge to 10" below	
Ripper Shank (Optional)	3 height adjustments from cutting edge depth to 5" below Spring tine tip	
Skid Shoe (Optional)	3/8" thick, replaceable	

Section 6: Features & Benefits

DT(M)55 Series Powered Ditcher

Features	Benefits
HP range	70 - 120 HP
Cat. 2 & 3	Fits wide variety of tractors.
Quick-Hitch adaptable	Quickly and easily attach Ditcher to tractor with one person.
Formed tubing hitch	Formed tubing with 1/4" wall offers greater strength vs. plate steel hitch.
540 & 1000 rpm models	Allows fitting larger tractors that are 1000 rpm only. Driveline available in 1 3/8" or 1 3/4".
20" Impeller	20" Impeller digs a nice size drainage or irrigation ditch.
6 Blades on impeller	6 Blades make digging easier and smoother than fewer blades.
3/8" Blades	Heavy-duty blades for long life.
3/8" Hardened cutting edge	Impeller blades feature a replaceable hardened edge to take on rough and rocky conditions. Easier and more cost effective to replace edge vs. using hard faced material on impeller.
Double 80 chain	Double 80, high tensile roller chain keeps stretching to a minimum and has the strength needed to take shock loads posed by extreme digging conditions.
Spring loaded chain idler	Chain idler is spring loaded to keep constant tension on chain during tough digging conditions, which also makes for smoother digging operations.
Hardened tooth sprockets	Hardened tooth sprockets have the strength needed to take the load of the double 80 chain and rigorous digging conditions.
2Greasable flange bearings	Input and output shafts feature 2 1/4" ID ball type bearings. Ball bearings offer smooth and quiet operation. Bearings are greasable to keep properly lubricated and purge dirt out.
4-Bolt cast iron flanges	Bearings are housed in a heavy-duty 4-bolt cast iron flange. Heavy-duty casting offers full protection under extreme use.
Cat. 5 Shear-bolt driveline	Heavy-duty driveline with shear-bolt protects the unit when obstructions are encountered.
Depth controlling skid shoe (optional)	Replaceable 3/8" thick skid shoe for long life and uniform depth control.
Material control chute (optional)	Material control chute allows the operator to place material just outside the tractor path, to as far away as the Ditcher will throw it. Control the throwing distance by raising or lowering the chute with either a 2" x 8" hydraulic cylinder or ratchet jack.
Depth control wheel (optional)	16.5 x 6.50-8 Pneumatic gauge wheel keeps digging depth constant from just skimming the ground to 10" deep.
Ripper shank (optional)	For hard packed soils, the Shank rips up the ground just ahead of the impeller, allowing the impeller to take in the soil vs. bouncing on hard packed soil. Shank has 3 height adjustments from cutting edge depth to 5" below cutting edge.

Section 7: Troubleshooting

Problem	Cause	Solution
Driveline Vibrates	Worn Universal Joint	Replace Universal Joint
Cutting Depth Insufficient	Machine carried by tractor	Lower 3-Point arms
	3-Point top link too long	Shorten top link
	Ground hard enough to require Ripper	Install Ripper
	Depth control set too low (Skid Shoe or Gauge Wheel)	Adjust to depth required
Rotor will not turn	Driveline not engaged	Engage driveline
	Shear bolt in clutch broken	Replace shear bolt in clutch
	Chain separated in case	Repair drive chain
Excessive noise in chain case	Chain loose	Adjust spring idler tension
	Sprocket to chain alignment	Adjust sprocket to chain alignment
	Spring loose from idler	Re-Hook spring to idler & adjust
Machine vibration	Debris & dirt lodged in rotor	Clean rotor
Ground cut insufficient	Worn cutting edges	Rotate or replace cutting edges



Section 8: Appendix

Torque Values Chart For Common Bolt Size													
Bolt Size (Inches) in-tpi ¹	Bolt Head Identification						Bolt Size (Metric) mm x pitch	Bolt Head Identification					
	Grade 2		Grade 5		Grade 8			Class 5.8		Class 8.8		Class 10.9	
	N · m	ft-lb ³	N · m	ft-lb	N · m	ft-lb		N · m	ft-lb	N · m	ft-lb	N · m	ft-lb
1/4" - 20	7.4	5.6	11	8	16	12	M 5 X 0.8	4	3	6	5	9	7
1/4" - 28	8.5	6	13	10	18	14	M 6 X 1	7	5	11	8	15	11
5/16" - 18	15	11	24	17	33	25	M 8 X 1.25	17	12	26	19	36	27
5/16" - 24	17	13	26	19	37	27	M 8 X 1	18	13	28	21	39	29
3/8" - 16	27	20	42	31	59	44	M10 X 1.5	33	24	52	39	72	53
3/8" - 24	31	22	47	35	67	49	M10 X 0.75	39	29	61	45	85	62
7/16" - 14	43	32	67	49	95	70	M12 X 1.75	58	42	91	67	125	93
7/16" - 20	49	36	75	55	105	78	M12 X 1.5	60	44	95	70	130	97
1/2" - 13	66	49	105	76	145	105	M12 X 1	90	66	105	77	145	105
1/2" - 20	75	55	115	85	165	120	M14 X 2	92	68	145	105	200	150
9/16" - 12	95	70	150	110	210	155	M14 X 1.5	99	73	155	115	215	160
9/16" - 18	105	79	165	120	235	170	M16 X 2	145	105	225	165	315	230
5/8" - 11	130	97	205	150	285	210	M16 X 1.5	155	115	240	180	335	245
5/8" - 18	150	110	230	170	325	240	M18 X 2.5	195	145	310	230	405	300
3/4" - 10	235	170	360	265	510	375	M18 X 1.5	220	165	350	260	485	355
3/4" - 16	260	190	405	295	570	420	M20 X 2.5	280	205	440	325	610	450
7/8" - 9	225	165	585	430	820	605	M20 X 1.5	310	230	650	480	900	665
7/8" - 14	250	185	640	475	905	670	M24 X 3	480	355	760	560	1050	780
1" - 8	340	250	875	645	1230	910	M24 X 2	525	390	830	610	1150	845
1" - 12	370	275	955	705	1350	995	M30 X 3.5	960	705	1510	1120	2100	1550
1-1/8" - 7	480	355	1080	795	1750	1290	M30 X 2	1060	785	1680	1240	2320	1710
1 1/8" - 12	540	395	1210	890	1960	1440	M36 X 3.5	1730	1270	2650	1950	3660	2700
1 1/4" - 7	680	500	1520	1120	2460	1820	M36 X 2	1880	1380	2960	2190	4100	3220
1 1/4" - 12	750	555	1680	1240	2730	2010	¹ in-tpi = nominal thread diameter in inches-threads per inch ² N · m = newton-meters ³ ft-lb= foot pounds ⁴ mm x pitch = nominal thread diameter in millimeters x thread pitch						
1 3/8" - 6	890	655	1990	1470	3230	2380							
1 3/8" - 12	1010	745	2270	1670	3680	2710							
1 1/2" - 6	1180	870	2640	1950	4290	3160							
1 1/2" - 12	1330	980	2970	2190	4820	3560							

Torque tolerance + 0%, -15% of torquing values. Unless otherwise specified use torque values listed above.

Tire Inflation Chart	
Tire Size	Inflation PSI
16.5 x 6.50-8 Pneumatic Tire	45

Section 8: Appendix

Notes

Warranty

Land Pride warrants to the original purchaser that this Land Pride product will be free from defects in material and workmanship beginning on the date of purchase by the end user according to the following schedule when used as intended and under normal service and conditions for personal use.

Overall Unit: One year Parts and Labor

Driveline: One year Parts and Labor

Impeller: One year Parts and Labor

Hydraulic Cylinder (If equipped): One year Parts and Labor

Impeller cutting edges, blade cutting edge, and ripper shank: Considered wear items

This Warranty is limited to the replacement of any defective part by Land Pride and the installation by the dealer of any such replacement part, and does not cover common wear items. Land Pride reserves the right to inspect any equipment or parts which are claimed to have been defective in material or workmanship.

This Warranty does not apply to any part or product which in Land Pride's judgment shall have been misused or damaged by accident or lack of normal maintenance or care, or which has been repaired or altered in a way which adversely affects its performance or reliability, or which has been used for a purpose for which the product is not designed. Misuse also specifically includes failure to properly maintain oil levels, grease points, and driveline shafts.

Claims under this Warranty should be made to the dealer which originally sold the product and all warranty adjustments must be made through an authorized Land Pride dealer. Land Pride reserves the right to make changes in materials or design of the product at any time without notice.

This Warranty shall not be interpreted to render Land Pride liable for damages of any kind, direct, consequential, or contingent to property. Furthermore, Land Pride shall not be liable for damages resulting from any cause beyond its reasonable control. This Warranty does not extend to loss of crops, any expense or loss for labor, supplies, rental machinery or for any other reason.

No other warranty of any kind whatsoever, express or implied, is made with respect to this sale; and all implied warranties of merchantability and fitness for a particular purpose which exceed the obligations set forth in this written warranty are hereby disclaimed and excluded from this sale.

This Warranty is not valid unless registered with Land Pride within 30 days from the date of purchase by the end user.



Corporate Office: P.O. Box 5060
Salina, Kansas 67402-5060 USA
www.landpride.com

Free Manuals Download Website

<http://myh66.com>

<http://usermanuals.us>

<http://www.somanuals.com>

<http://www.4manuals.cc>

<http://www.manual-lib.com>

<http://www.404manual.com>

<http://www.luxmanual.com>

<http://aubethermostatmanual.com>

Golf course search by state

<http://golfingnear.com>

Email search by domain

<http://emailbydomain.com>

Auto manuals search

<http://auto.somanuals.com>

TV manuals search

<http://tv.somanuals.com>