



OWNER'S MANUAL

JWBS-20 Woodworking Bandsaw



JET EQUIPMENT & TOOLS, INC.
A WMH Company
www.jettools.com

P.O. BOX 1349
Auburn, WA 98071-1349
e-mail jet@jettools.com

Phone: 253-351-6000
Fax: 1-800-274-6840
M-708752 11/01

This manual has been prepared for the owner and operators of a JET JWBS-20 Woodworking Bandsaw. Its purpose, aside from machine operation, is to promote safety through the use of accepted correct operating and maintenance procedures. Completely read the safety and maintenance instructions before operating or servicing the machine. To obtain maximum life and efficiency from your Bandsaw, and to aid in using the machine safely, read this manual thoroughly and follow instructions carefully.

Warranty & Service

The JET Group warrants every product it sells. If one of our tools needs service or repair, one of our Authorized Repair Stations located throughout the United States can give you quick service.

In most cases, any one of these JET Group Repair Stations can authorize warranty repair, assist you in obtaining parts, or perform routine maintenance and major repair on your JET, Performax or Powermatic tools.

For the name of an Authorized Repair Station in your area, please call 1-800-274-6848.

More Information

Remember, the JET Group is consistently adding new products to the line. For complete, up-to-date product information, check with your local JET Group distributor.

JET Group Warranty

The JET Group (including Performax and Powermatic brands) makes every effort to assure that its products meet high quality and durability standards and warrants to the original retail consumer/purchaser of our products that each product be free from defects in materials and workmanship as follow: 1 YEAR LIMITED WARRANTY ON ALL PRODUCTS UNLESS SPECIFIED OTHERWISE. This Warranty does not apply to defects due directly or indirectly to misuse, abuse, negligence or accidents, normal wear-and-tear, repair or alterations outside our facilities, or to a lack of maintenance.

THE JET GROUP LIMITS ALL IMPLIED WARRANTIES TO THE PERIOD SPECIFIED ABOVE, FROM THE DATE THE PRODUCT WAS PURCHASED AT RETAIL. EXCEPT AS STATED HEREIN, ANY IMPLIED WARRANTIES OR MERCHANTABILITY AND FITNESS ARE EXCLUDED. SOME STATES DO NOT ALLOW LIMITATIONS ON HOW LONG THE IMPLIED WARRANTY LASTS, SO THE ABOVE LIMITATION MAY NOT APPLY TO YOU. THE JET GROUP SHALL IN NO EVENT BE LIABLE FOR DEATH, INJURIES TO PERSONS OR PROPERTY, OR FOR INCIDENTAL, CONTINGENT, SPECIAL, OR CONSEQUENTIAL DAMAGES ARISING FROM THE USE OF OUR PRODUCTS. SOME STATES DO NOT ALLOW THE EXCLUSION OR LIMITATION OF INCIDENTAL OR CONSEQUENTIAL DAMAGES, SO THE ABOVE LIMITATION OR EXCLUSION MAY NOT APPLY TO YOU.

To take advantage of this warranty, the product or part must be returned for examination, postage prepaid, to an Authorized Repair Station designated by our office. Proof of purchase date and an explanation of the complaint must accompany the merchandise. If our inspection discloses a defect, we will either repair or replace the product, or refund the purchase price if we cannot readily and quickly provide a repair or replacement, if you are willing to accept a refund. We will return repaired product or replacement at JET'S expense, but if it is determined there is no defect, or that the defect resulted from causes not within the scope of JET'S warranty, then the user must bear the cost of storing and returning the product. This warranty gives you specific legal rights; you may also have other rights which vary from state to state.

The JET Group sells through distributors only. Members of the JET Group reserve the right to effect at any time, without prior notice, those alterations to parts, fittings, and accessory equipment which they may deem necessary for any reason whatsoever.

WARNING

1. **Read and understand the entire instruction manual before attempting assembly or operation.**
2. **This band saw is designed and intended for use by properly trained and experienced personnel only. If you are not familiar with the proper and safe operation of a bandsaw, do not use until proper training and knowledge have been obtained.**
3. Always wear approved safety glasses/face shields while using this machine.
4. Make certain the machine is properly grounded.
5. Before operating the machine, remove tie, rings, watches, other jewelry, and roll up sleeves above the elbow. Remove all loose clothing and confine long hair. Do **not** wear gloves.
6. Keep the floor around the machine clean and free of scrap material, oil and grease.
7. Keep the machine guards in place at all times when the machine is in use. If removed for maintenance purposes, use extreme caution and replace the guards immediately.
8. Do not over reach. Maintain a balanced stance at all times so that you do not fall or lean against blades or other moving parts.
9. Make all machine adjustments or maintenance with the machine unplugged from the power source.
10. Use the right tool. Don't force a tool or attachment to do a job which it was not designed for.
11. Replace warning labels if they become obscured or removed.
12. Make certain the bandsaw power switch is in the off position before connecting the machine to the power supply.
13. Give your work undivided attention. Looking around, carrying on a conversation, and "horse-play" are careless acts that can result in serious injury.
14. Keep visitors a safe distance from the work area.
15. Use recommended accessories; improper accessories may be hazardous.
16. Adjust and position upper and lower blade guides before starting to cut. Upper blade guide should be adjusted to approximately 1/8" above the material to be cut.
17. Adjust blade tension and tracking before starting to cut.
18. Always keep hands and fingers away from the blade when the machine is running.
19. Stop the machine and wait for the blade to stop moving before removing scrap material from the table.
20. Use suitable support if stock does not have a flat surface.
21. Hold material firmly against the table.
22. Saw teeth must point down toward the table.
23. Some dust created by power sanding, sawing, grinding, drilling and other construction activities contains chemicals known to cause cancer, birth defects or other reproductive harm. Some examples of these chemicals are:
 - Lead from lead based paint
 - crystalline silica from bricks and cement and other masonry products, and
 - arsenic and chromium from chemically-treated lumber.
24. Your risk from those exposures varies, depending on how often you do this type of work. To reduce your exposure to these chemicals: work in a well ventilated area, and work with approved safety equipment, such as those dust masks that are specifically designed to filter out microscopic particles.
25. Do not operate tool while under the influence of drugs, alcohol or any medication.
26. **Failure to comply with all of these warnings may cause serious injury.**

Table of Contents

Warranty	2
Warnings.....	3
Table of Contents	4
Specifications	4
Contents of Shipping Container	5
Unpacking and Setup.....	5
Tools Included for Assembly.....	5
Tools Required for Assembly and Adjustments	5
Upper Bearing Guide Adjustment.....	6
Lower Bearing Guide Adjustment.....	7
Mounting the Table.....	7
Adjusting 90 Degree Table Stop	8
Rail Assembly.....	8
Fence Assembly and Adjustment.....	9
Resaw Guide	10
Miter Gauge.....	10
Tilting the Table.....	10
Height Scale Adjustment	10
Changing Blades	11
Adjusting Blade Tension	12
Adjusting Blade Tracking	12
Brake Pedal.....	13
Replacing Belt	13
Adjusting Belt Tension	13
Electrical Connections	14
Maintenance.....	14
Troubleshooting.....	15
Part's Breakdowns and Part's List.....	16-25
Electrical Schematics	26

Specifications:

JWBS-20

Stock Number.....	708752
Cutting Capacity (HxW)	12-1/2" x 20"
Maximum Rip Left of Blade w/Fence	18-1/4"
Maximum Rip Right of Blade w/Fence.....	9-3/4"
Blade Length	150"
Minimum Blade Width	1/8"
Maximum Blade Width	1-1/2"
Table Size	21" x 21"
Table Tilt	45°R to 10°L
Table Height.....	36-1/8"
Front Table to Center of Blade.....	11"
Wheel Diameter	20-1/2"
Blade Speed.....	3,450 SFPM
Dust Chute Diameter	4"
Overall Dimensions (HxWxD).....	75-1/4" x 41-1/4" x 34-1/2"
Motor (TEFC)	2 HP, 1Ph
.....	230V only
Net Weight (approx.)	500 lbs.
Shipping Weight (approx.)	564 lbs.

The specifications in this manual are given as general information and are not binding. JET Equipment and Tools reserves the right to effect, at any time and without prior notice, changes or alterations to parts, fittings, and accessory equipment deemed necessary for any reason whatsoever.

Contents of Shipping Container

1. Bandsaw
1. Table
1. Fence and Rail Assembly
1. Resaw Guide and Knob
1. Miter Gauge
1. Owner's Manual
1. Warranty Card
1. Hardware Package
 2. Knobs
 1. Hex Wrench
 1. Handle
 1. 10/12mm Wrench
1. Fence Hardware Bag
 4. Hex Cap Screws
 4. Flat Washers
 4. Lock Washer
1. Rail Hardware Bag
 9. Hex Cap Screws
 9. Flat Washers
 9. Lock Washers



Unpacking and Setup

1. Remove the crate and packing material from the saw except for the transport skid on the bottom.
2. Move the saw to its permanent working location. The site should be dry, well lit, and have enough room to handle long stock and the service and/or adjustment of the machine from any side.
3. Move the bandsaw off the skid.
4. Clean all rust protected surfaces with a mild solvent or diesel fuel and a soft cloth. Do not use lacquer thinner, paint thinner, or gasoline. These will damage painted surfaces.

Tools Included for Assembly

1. 10/12mm Open End Wrench
1. Hex Wrench

Tools Required for Assembly & Adjustments

2. 14mm Open End Wrench
1. Cross Point Screw Driver
1. Combination Square

Assembly and Setup

1. Attach the handle (A, Fig. 1) to the handwheel (B, Fig. 1).
2. Turn blade tension hand wheel (C, Fig. 1) counter-clockwise to tension blade and clockwise to loosen the tension. A gauge on the upper wheel slide bracket (D, Fig. 1) indicates the approximate tension according to the width of the blade. The JWBS-20 comes with a 1" blade so the tension should be set at 1".

Note: It is easier to adjust the bearing guides before mounting the table.

Upper Bearing Guide Adjustment

WARNING

Disconnect machine from the power source, unplug before making any adjustments!
Blade teeth are sharp! Use care when working near the saw blade.
Failure to comply may cause serious injury!

1. **Disconnect the machine from the power source, unplug.**
2. Blade tension must be properly adjusted prior to bearing guide setup, see "Adjusting Blade Tension" page 13.
3. Adjust the back-up bearing (E, Fig. 2) so that it is 0.003" away from the back of the blade, about the thickness of a piece of paper. To make this adjustment loosen thumb screw (F, Fig. 2) and slide the bearing and bearing post into position. Tighten thumb screw.
4. Loosen the socket head cap screw (G, Fig. 3) and slide the bearing assembly until the bearing guides rest just behind the gullet of the blade teeth. You may need to readjust the back-up bearing.
5. Loosen the wing nut (H, Fig. 3) and turn the adjusting screw (I, Fig. 3) clockwise or counter-clockwise until the bearing is 0.003" away from the side of the blade, about the thickness of a piece of paper. Tighten wing nut.
6. Adjust the opposite side bearing.
7. Check to make sure the adjustments have not changed and the bearing guides do not pinch the blade.

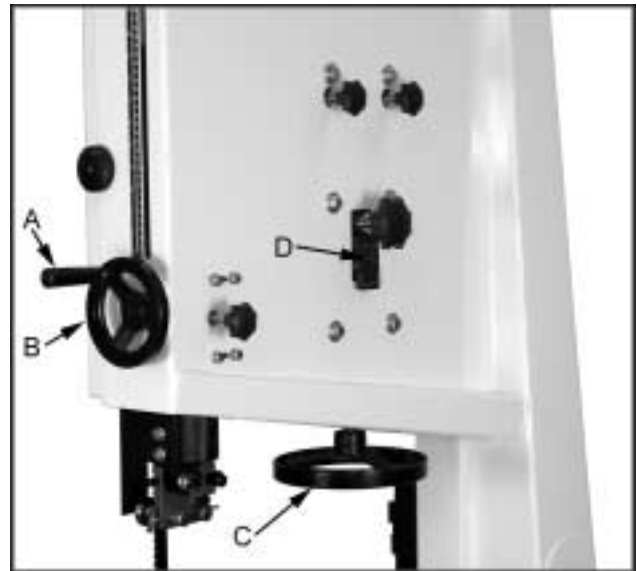

Fig. 1

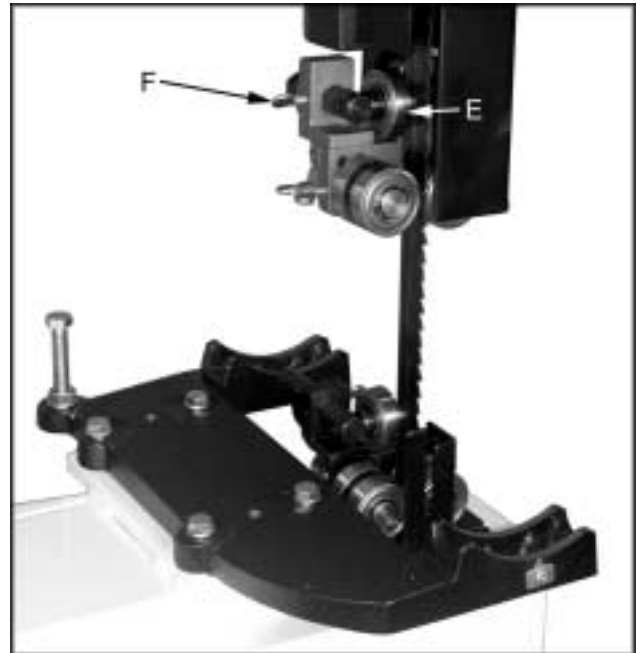

Fig. 2

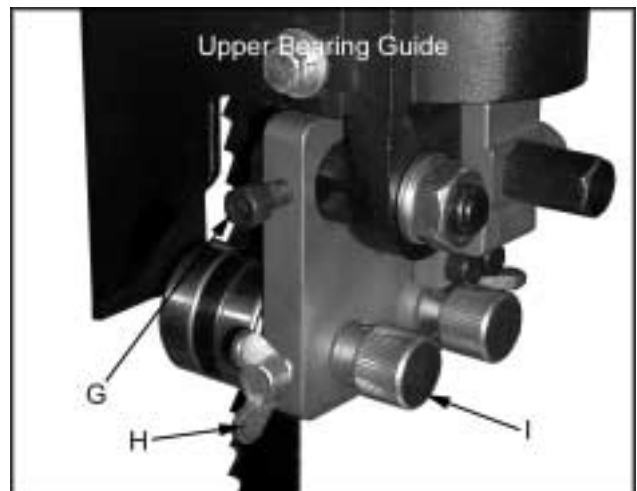

Fig. 3

Lower Bearing Guide Adjustment

WARNING

Disconnect machine from the power source, unplug before making any adjustments!
Blade teeth are sharp! Use care when working near the saw blade.
Failure to comply may cause serious injury!

1. **Disconnect the machine from the power source, unplug.**
2. Blade tension must be properly adjusted prior to bearing guide setup, see "Adjusting Blade Tension" page 13.
3. Adjust the back-up bearing (A, Fig. 4) so that it is 0.003" away from the back of the blade, about the thickness of a piece of paper. To make this adjustment loosen thumb screw (B, Fig. 4) and slide the bearing, and bearing post into position. Tighten thumb screw.
4. Loosen the socket head cap screw (C, Fig. 4) and slide the bearing assembly until the bearing guides rest just behind the gullet of the blade teeth. You may need to readjust the back-up bearing. Tighten socket head cap screw.
5. Loosen the thumb screw (D, Fig. 4) and turn adjusting screw (E, Fig. 4) clockwise or counter-clockwise until the bearing is 0.003" away from the side of the blade, about the thickness of a piece of paper.
6. Adjust the opposite side bearing.
7. Tighten thumb screw (D, Fig. 4). Check to make sure the adjustments have not changed and the bearing guides do not pinch the blade.

Mounting the Table

1. With help from another person mount the table. Remove the table insert (F, Fig. 5) and table pin (G, Fig. 5).
2. Slide saw blade through slot in table where the table pin was located. Rotate the table 90 degrees so that the miter slot is parallel to the blade, and to the right of the blade when facing the bandsaw.
3. Line up the trunnions so that the bolts feed through the trunnion support bracket. Secure the table with two lock knobs (H, Fig. 6). Reinstall the table insert and table pin.

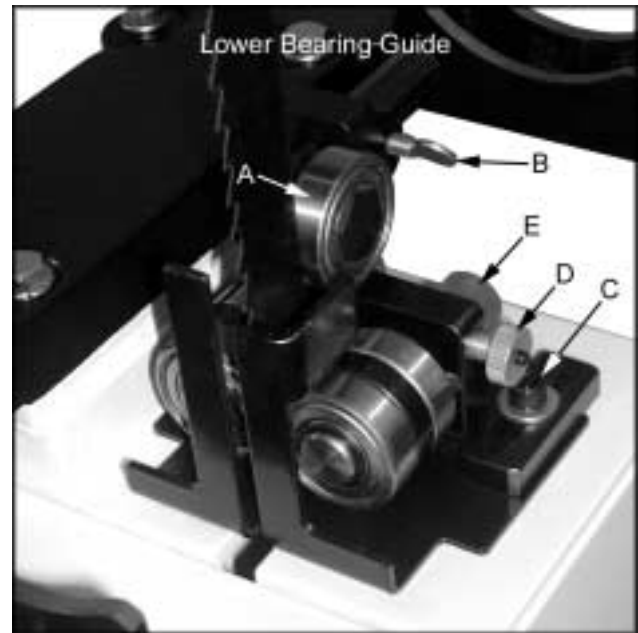

Fig. 4

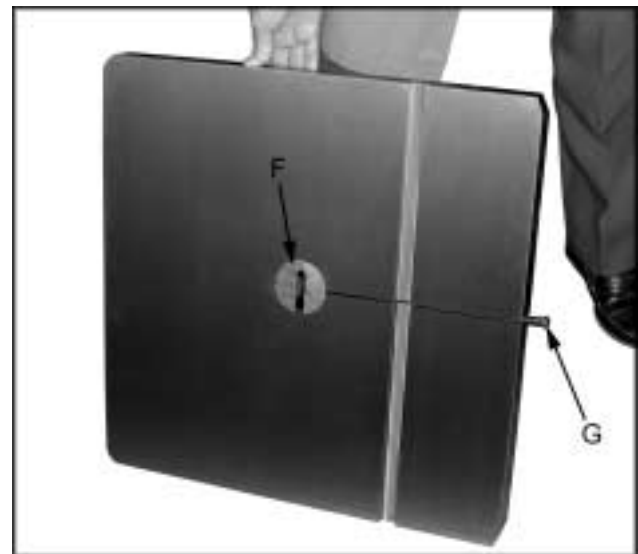

Fig. 5

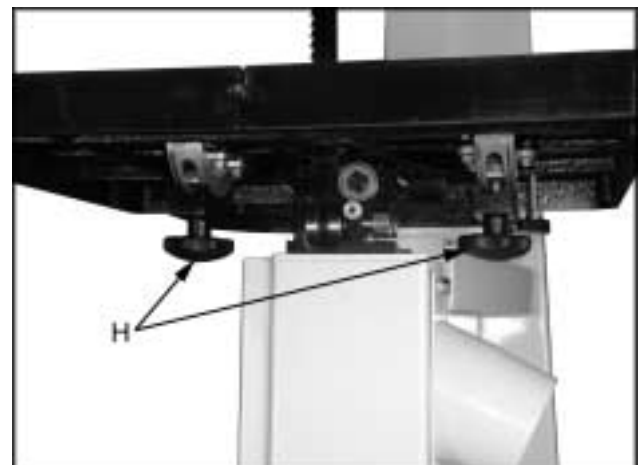

Fig. 6

Adjusting 90 Degree Table Stop

1. Blade tension must be properly adjusted prior to adjusting 90 degree stop, see "Adjusting Blade Tension" page 13.
2. Loosen lock knobs (A, Fig. 7) and tilt table until it rests against table stop bolt (B, Fig. 7). Tighten knobs.
3. Use a square (E, Fig. 8) placed on the table and against the blade to see if the table is 90 degrees to the blade.
4. If an adjustment is necessary, loosen the lock knobs. Tilt the table until it is square to the blade, and tighten the lock knobs.
5. Loosen lock nut (C, Fig. 7) and turn table stop bolt (B, Fig. 7) until it contacts the table. Tighten the nut (C, Fig. 7) to hold table stop in place. When tightening the nut hold the table stop bolt in place with a wrench to prevent movement.
6. If necessary, adjust pointer (D, Fig. 7) to zero.

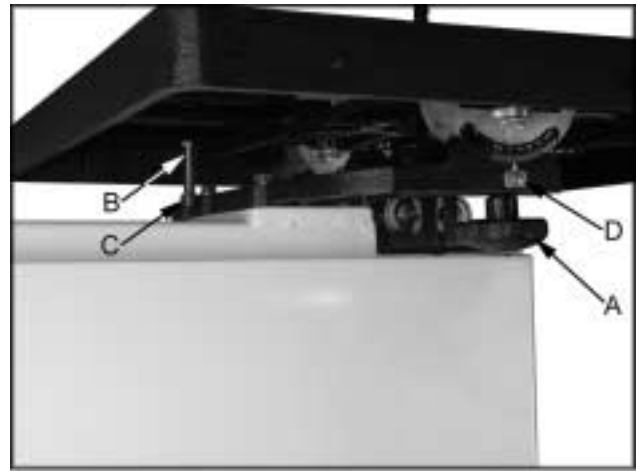

Fig. 7

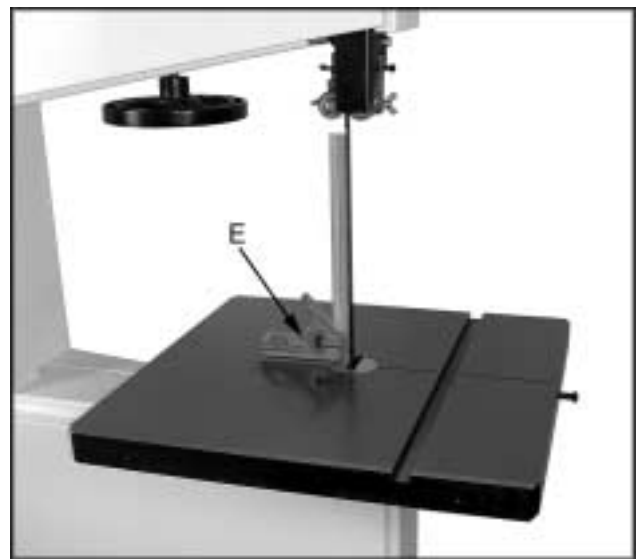

Fig. 8

Rail Assembly

1. Attach the front rail (F, Fig. 9) to the cast iron table with two 1/4" x 5/8" hex cap bolts, two 1/4" lock washers, and two 1/4" flat washers. Bolts should be in approximately the center of the slot. Hand tighten only at this time.
2. Attach the rear rail (G, Fig. 9) to the table with two 1/4" x 5/8" hex cap bolts, two 1/4" lock washers, and two 1/4" flat washers. Bolts should be in approximately the center of the slot. Hand tighten only at this time.
3. Push the front, and rear rails up as far as they will go.
4. Tighten the four hex cap bolts holding the front, and rear rails to the table. **Do not** over tighten the bolts.
5. Attach the guide tube (H, Fig. 9) to the front rail with five 1/4" x 5/8" hex cap bolts, five 1/4" lock washers, and five 1/4" flat washers. Bolts should be in approximately the center of the slot.



Fig. 9

Fence Assembly and Adjustment

1. Attach the fence (A, Fig. 10) to the fence body (B, Fig. 10) with four 5/16" x 3/4" hex cap bolts, four 5/16" lock washers, and four 5/16" flat washers.
2. Thread a hex nut (D, Fig. 11) onto the pad's threaded stud (E, Fig. 11) and insert through the fence and rear hook (F, Fig. 11). Secure in place using a hex nut, lock washer and flat washer (G, Fig. 11).

Note: The hook should be adjusted so that it overlaps the rear rail by approximately 1/8".

3. Place fence assembly onto the guide tube. The rear hook should engage the rear rail.
4. Check the clearance between the table and the fence. The gap should be the same at the front of the table as it is at the rear. If the gap width is different, adjust the foot at the rear of the fence until the gap width is the same, Figure 12.

Note: You can also adjust the front rail, or rear rail up, or down to achieve the proper clearance.

5. With a square verify the fence face is perpendicular to the table top. If it is not the front rail will need to be adjusted parallel to the table top. This can be accomplished by measuring from the top of the table to the top of the front rail. The measurement should be the same at both ends of the table.
6. Move the fence assembly so that it aligns parallel to the blade, and lock the fence by pushing the lock handle down, Figure 10.
7. Loosen the four hex cap bolts that hold the fence, to the fence body, and align the fence to the blade. Tighten the four hex cap bolts.
8. Check to see that the pointer (C, Fig. 10) is aligned with the zero marking on the guide rail. If adjustment is necessary loosen the screw that holds the pointer in place and line up to the zero mark. Tighten the screw.

Note: If you cannot get the pointer lined up with the zero mark you can slide the guide tube and front rail left, or right to achieve the proper setting.



Fig. 10

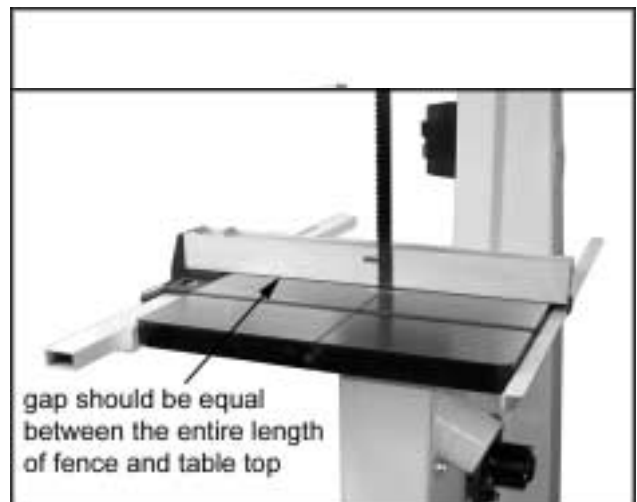

Fig. 12

Fig. 11

Resaw Guide

For resawing attach the post (A, Fig. 13) to fence with the lock knob (B, Fig. 13). There is a slotted hole in the fence that will accommodate the resaw kit. Position the post so that it is centered with the front edge of the blade.

Miter Gauge

1. Place the miter gauge in the table slot.
2. With a square verify the miter gauge face is square to the blade.
3. If the miter gauge is not square to the blade loosen the lock knob (C, Fig. 13) and adjust to the proper setting. Tighten the lock knob.
4. If the pointer is not at 90 degrees, loosen the screw (D, Fig. 13) holding the pointer and move the pointer to 90 degrees.

Tilting the Table

1. **Disconnect the machine from the power source, unplug.**
2. Loosen the lock knobs (E, Fig. 14).
3. Tilt table up to 45 degrees to the right, or up to 10 degrees to the left.
4. Tighten the lock knobs.

Note: Table stop bolt (F, Fig. 14) must be removed to tilt table to the left.

Height Scale Adjustment

1. **Disconnect the machine from the power source, unplug.**
2. The upper bearing guide should be set about 1/8" above the material to be cut.
3. Measure from the table top to the bottom of the bearing guides.
4. Set the indicator to this measurement on the height scale. Grasp the end of the indicator (G, Fig. 15) between your finger, and thumb. Move the indicator into position.

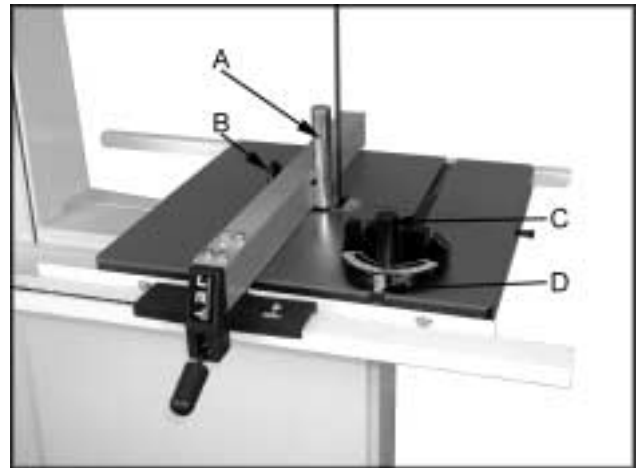

Fig. 13

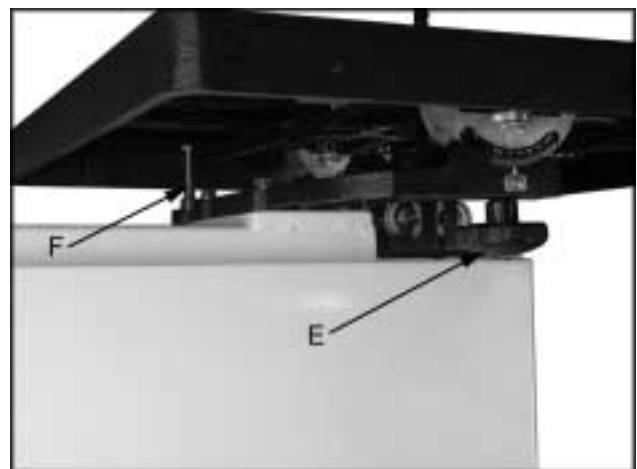

Fig. 14

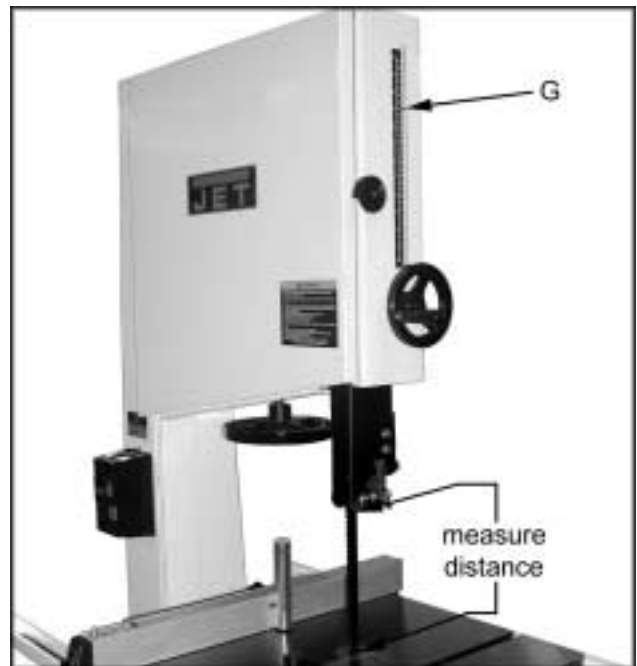

Fig. 15

Changing Blades

WARNING

Disconnect machine from the power source, unplug!

Blade teeth are sharp! Use care when handling the saw blade.

Failure to comply may cause serious injury!

1. **Disconnect the machine from the power source.**
2. Remove the table insert (A, Fig. 16), and table pin (B, Fig. 16).
3. Lower the upper blade guide assembly about half way by loosening the lock knob (F, Fig. 17) and turning the hand wheel (G, Fig. 17)
4. Loosen socket head cap screw (C, Fig. 16) and slide the bearing assembly back as far as it will go.
5. Open both wheel covers (D, Fig. 16).
6. Loosen blade tension by turning blade tension hand wheel (E, Fig. 17) clockwise until it stops.

Note: You may want to wear leather work gloves while removing and handling the blade.

7. Carefully remove blade from upper and lower wheels. Remove the blade from between upper, and lower bearing guides. Turn blade and direct through slot in table.
8. Make sure blade teeth point down toward table and guide the new blade through table slot. Place blade in upper, and lower bearing guides.
9. Place blade in the middle of the upper and lower wheels.
10. Spin the upper wheel a number of revolutions and see where the blade lines up. Tension and track blade before operating saw. Find instructions for tensioning and tracking the blade on the next page under "Adjusting Blade Tension" and "Adjusting Blade Tracking".
11. Replace table insert and table pin.

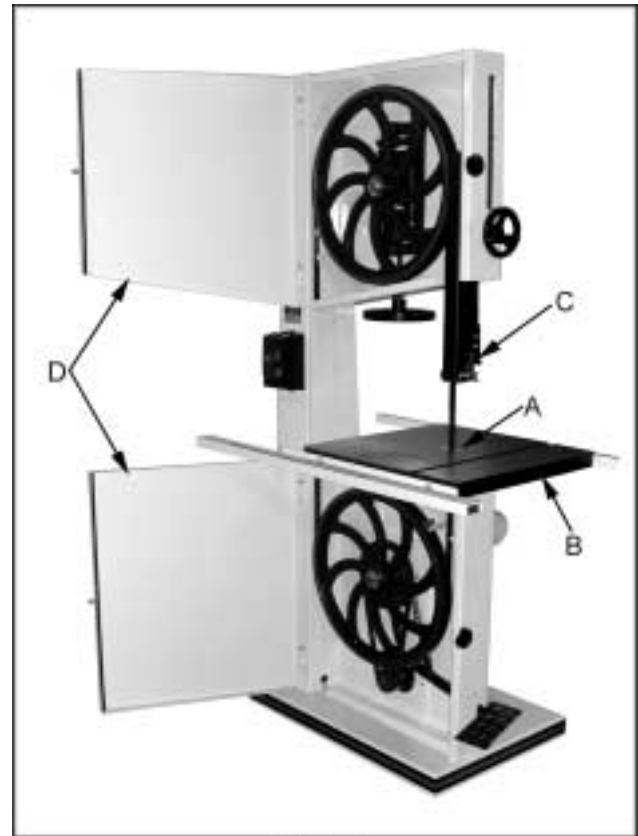

Fig. 16



Fig. 17

Adjusting Blade Tension

1. **Disconnect machine from the power source, unplug.**
 2. Turn blade tension hand wheel (A, Fig. 18) counter-clockwise to tension blade, and clockwise to loosen the tension. A gauge on the upper wheel slide bracket (B, Fig. 18) indicates the approximate tension according to the width of the blade. The JWBS-20 comes with a 1" blade so the tension should be set at 1" when using this blade.
- As you become familiar with the saw, you may find it necessary to change the blade tension from the initial setting. Changes in blade width, and the type of material being cut will have an effect on blade tension.
 - Keep in mind that too little, or too much blade tension can cause blade breakage and/or poor cutting performance.

Adjusting Blade Tracking

⚠ WARNING
Disconnect machine from the power source!
Never adjust blade tracking with the machine running!
Failure to comply may cause serious injury!

Note: Blade tracking has been adjusted at the factory. If, however, it is determined that blade tracking needs adjustment, make this adjustment with knob (C, Fig. 19).

Do not use knobs (D, Fig. 19). They are used by the factory for wheel alignment **not** tracking.

1. **Disconnect the machine from the power source.**
2. Blade must be properly tensioned before adjusting blade tracking. Make sure upper and, lower bearing guides do not interfere with the blade while adjusting the tracking.
3. Open upper wheel door. Rotate the wheel forward, and observe the position of the blade on the wheel. The blade should rest in approximately the center of the wheel.
4. If adjustment is necessary, loosen the wing nut (E, Fig. 19) at the top rear of the saw.
5. Adjust tracking by turning the knob (C, Fig. 19) in 1/4 turn increments. Rotate the wheel forward, and observe the position of the

blade on the wheel. Rotating knob (C, Fig. 19) counter-clockwise should move the blade towards the front of the wheel. Rotating the knob (C, Fig. 19) clockwise should move the blade towards the back of the wheel.

6. Continue with adjustments until the blade is tracking properly.
7. Tighten the wing nut (E, Fig. 19) after blade is tracking in the center of the wheel.



Fig. 18



Fig. 19

Brake Pedal

Depress the brake pedal (A, Fig. 20) while the saw is running to stop the saw. Re-start the saw by pressing the on switch.

Replacing Belt

1. **Disconnect the machine from the power source.**
2. Release blade tension by turning blade tension hand wheel clockwise.
3. Release belt tension by loosening the hex cap bolt (B, Fig. 20). Raise the motor and place a block of wood under the motor to take the tension off the belt.
4. Open the lower wheel door and remove hex nut, and washer (C, Fig.21).
5. If the lower wheel does not come off easily you may need to use a pulley puller (D, Fig. 22) to remove the lower wheel.
6. Remove the old belt (E, Fig. 22) and replace the belt.
7. Reinstall the lower wheel and tighten the hex nut.
8. Set the blade tension. See "Adjusting Blade Tension" on the previous page.
9. Remove the wood block, or support from below the motor and adjust the belt tension. See "Adjusting the Belt Tension."
10. Check the blade tracking. See "Adjusting Blade Tracking" on the previous page.

Adjusting Belt Tension

The belt comes adjusted from the factory. If adjustment is needed:

1. **Disconnect the machine from the power source.**
2. Set the belt tension by lightly pressing down on the motor and tightening the hex cap screw (B, Fig. 20).
3. The weight of the motor should put enough tension on the belt. You just want to push down lightly to take up any slack.



Fig. 20



Fig. 21

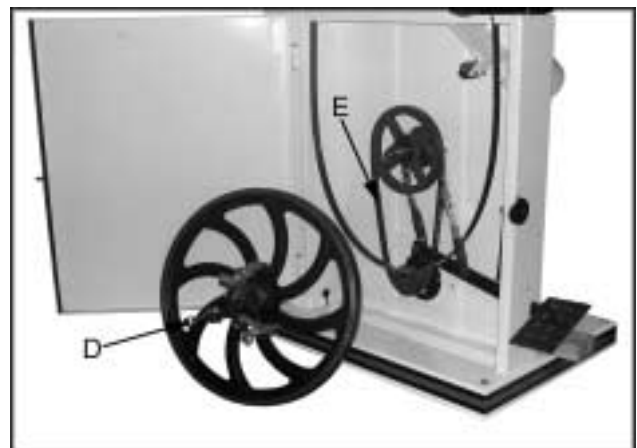

Fig. 22

Electrical Connections

WARNING!

**All electrical connections must be done by a qualified electrician!
Failure to comply may result in loss of property and/or serious injury!**

- **JWBS-20 is rated at 2 HP, 1Ph, 230V only.**

A plug needs to be purchased for the bandsaw that matches the outlet you intend to use (A, Fig. 23).

Confirm power at the site is the same as the saw before making any electrical connections. Review the electrical schematic on page 26.

The on/off switch (B, Fig. 24) is thermally protected. If the saw motor is overloaded, or a momentary interruption of electrical current is sensed, the saw will shut off. Allow a few minutes for the saw to cool down and **reset by pushing the off button.**

Maintenance

Keep bearing guides clean and free of build up.

Do not let saw dust build up in the upper and lower wheel housings. Vacuum out frequently.

Keep the brake switch, located in the lower wheel housing, clean and free of saw dust.

Connect the bandsaw to a JET dust collection system.

Clean and grease the raising/lowering rack for the upper bearing guides if it becomes difficult to raise, or lower.

Clean, and oil the tensioning mechanism if it becomes difficult to adjust.

Vacuum out the motor fan cover.

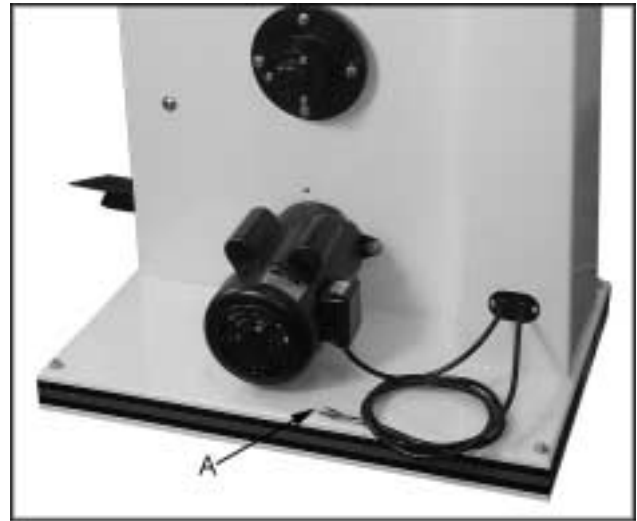

Fig. 23

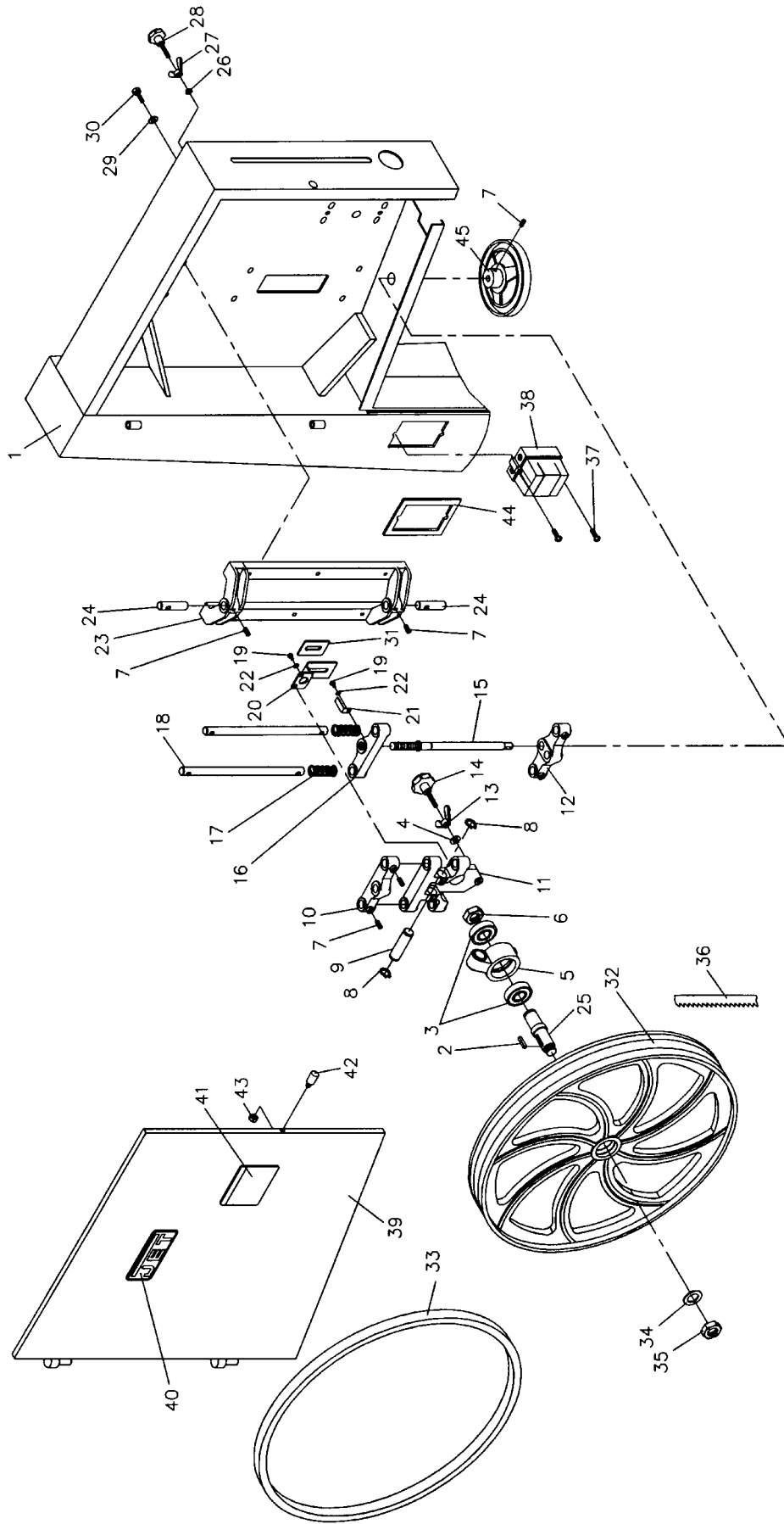

Fig. 24

Troubleshooting

Trouble	Possible Cause	Solution
Saw stops or will not start	<ol style="list-style-type: none"> 1. Overload tripped 2. Saw unplugged 3. Fuse blown or circuit breaker tripped 4. Cord damaged 	<ol style="list-style-type: none"> 1. Allow motor to cool and reset by pushing off switch 2. Check plug connections 3. Replace fuse or reset circuit breaker 4. Replace cord
Does not make accurate 45° or 90° cuts	<ol style="list-style-type: none"> 1. Stop not adjusted correctly 2. Angle pointer not set accurately 3. Miter gauge out of adjustment 	<ol style="list-style-type: none"> 1. Check blade with square and adjust stop 2. Check blade with square and adjust pointer 3. Adjust miter gauge
Blade wanders during cut	<ol style="list-style-type: none"> 1. Fence not aligned with blade 2. Warped wood 3. Excessive feed rate 4. Incorrect blade for cut 	<ol style="list-style-type: none"> 1. Check and adjust fence 2. Select another piece of wood 3. Reduce feed rate 4. Change blade to correct type
Saw makes unsatisfactory cuts	<ol style="list-style-type: none"> 1. Dull blade 2. Blade mounted wrong 3. Gum or pitch on blade 4. Incorrect blade for cut 5. Gum or pitch on table 	<ol style="list-style-type: none"> 1. Replace blade 2. Teeth should point down 3. Remove blade and clean 4. Change blade to correct type 5. Clean table
Blade does not come up to speed	<ol style="list-style-type: none"> 1. Extension cord too light or too long 2. Low shop voltage 	<ol style="list-style-type: none"> 1. Replace with adequate size cord 2. Contact your local electric company
Saw vibrates excessively	<ol style="list-style-type: none"> 1. Base on uneven floor 2. Bad V-belt 3. Bent pulley 4. Improper motor mounting 5. Loose hardware 	<ol style="list-style-type: none"> 1. Reposition on flat, level surface 2. Replace V-belt 3. Replace pulley 4. Check and adjust motor 5. Tighten hardware

Upper Wheel Assembly



Upper Wheel Assembly

Index No.	Part No.	Description	Size	Qty.
1	JWBS20-501	Saw Body		1
2	JWBS20-49	Key	7 x 7 x 25	1
3	BB-6205LLU	Ball Bearing	6205	2
4	TS-0720091	Lock Washer	3/8	1
5	JWBS20-44	Upper Wheel Bearing Bracket		1
6	JWBS20-506	Lock Nut	3/4-16 UNF R.H.	1
7	TS-0270051	Socket Set Screw	5/16-18 x 1/2	5
8	JWBS20-40	C-Ring	S-20	2
9	JWBS20-43	Lever Shaft		1
10	JWBS20-42	Upper Adjustment Bracket		1
11	JWBS20-39	Upper Wheel Guide Bracket		1
12	JWBS20-38	Adjustment Bracket		1
13	JWBS20-41A	Wing Nut		1
14	JWBS20-41	Lock Knob		1
15	JWBS20-37	Adjustment Screw		1
16	JWBS20-36	Elevator Bracket		1
17	JWBS20-35	Spring		2
18	JWBS20-34	Guide Bar		2
19	JWBS20-56D	Screw	3/16 x 5/8	3
20	JWBS20-56B	Bracket		1
21	JWBS20-56A	Pointer		1
22	JWBS20-56C	Lock Washer	3/16	3
23	JWBS20-33	Upper Wheel Bracket Base		1
24	JWBS20-32	Bracket Shaft		2
25	JWBS20-525	Upper Wheel Shaft		1
26	TS-0720081	Lock Washer	5/16	2
27	TS-0590061	Wing Nut	5/16	2
28	JWBS20-54	Lock Knob		2
29	TS-0680041	Flat Washer	3/8	6
30	TS-0060081	Hex Cap Bolt	3/8 x 1-3/4	6
31	JWBS20-56E	Blade Width Gauge		1
32	JWBS20-532	Upper Wheel		1
33	JWBS20-21	Tire		1
34	TS-0680091	Flat Washer	3/4	1
35	JWBS20-22	Hex Nut	3/4-16UNF L.H.	1
36	709482	1/4" x 0.025" x 6 Skip Blade	150"	
	709483	3/8" x 0.025 x 4 Skip Blade	150"	
	709484	1/2" x 0.025 x 3 Hook Blade	150"	
	709485	3/4" x 0.032 x 3 Hook Blade	150"	
	709486	1" x 0.035 x 2 Hook Blade	150"	
	709487	1-1/4" x 0.035 x 1.3 Hook Blade	150"	
37	JWBS20-537	Screw	3/16 x 3/4	2
38	JWBS20-14	On/Off Switch	230V, 1Ph.	1
39	JWBS20-539	Upper Front Door		1
40	JWBS18-140	JET Plaque		1
41	JWBS18-141	Warning Label		1
42	JWBS20-542	Door Stud		1
43	TS-0561011	Hex Nut	1/4 x 20	1
44	JWBS20-544	Switch Plate		1
45	JWBS20-50	Hand Wheel		1

Lower Wheel and Motor Assembly

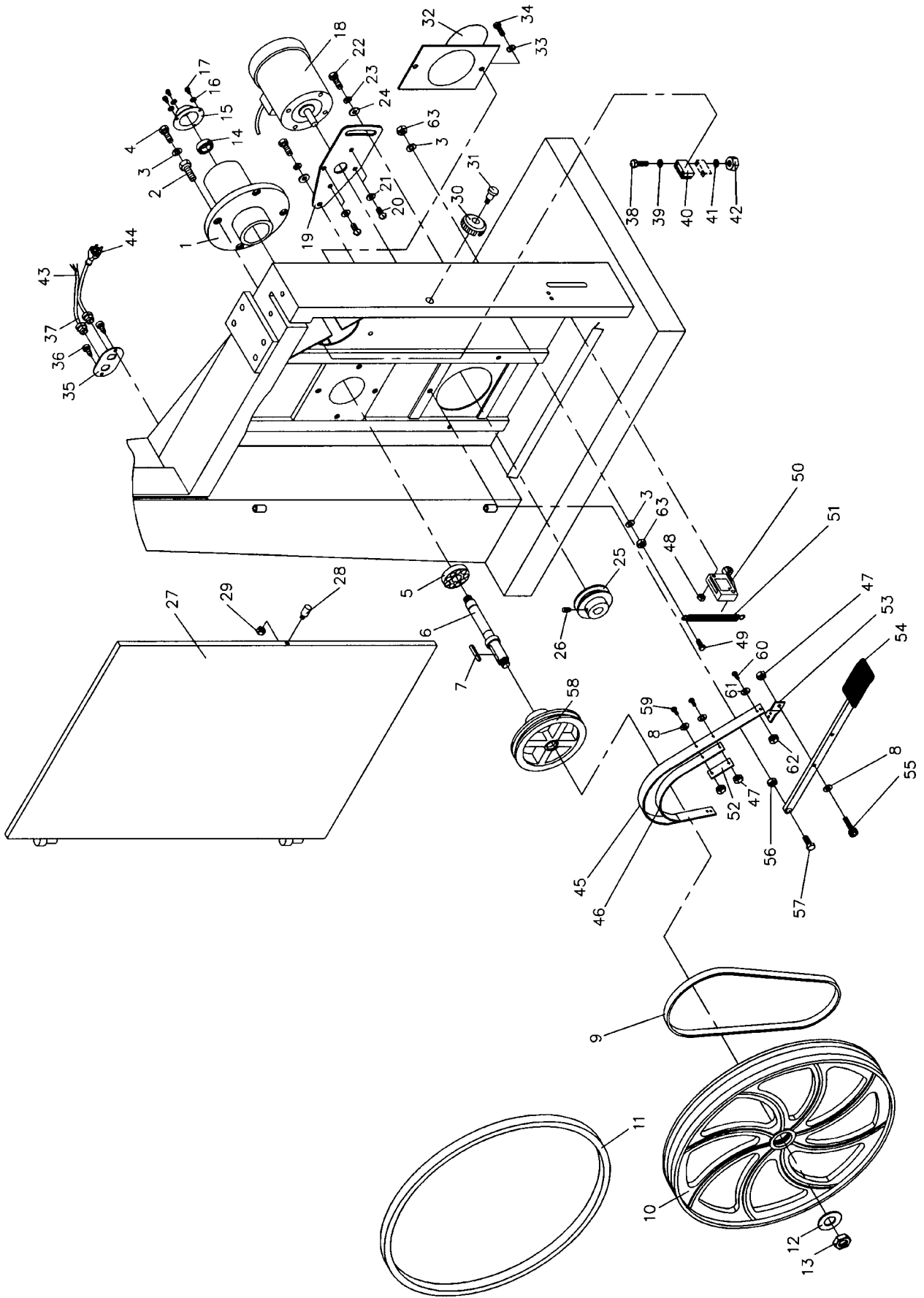

Lower Wheel and Motor Assembly

Index No.	Part No.	Description	Size	Qty.
1	JWBS20-201	Bearing Base		1
2	JWBS20-62	Adjusting Bolt		4
3	TS-0720091	Lock Washer	3/8	6
4	TS-0060081	Hex Cap Bolt	3/8 x 1-3/4	4
5	BB-6205ZZ	Ball Bearing	6205	2
6	JWBS20-206	Spindle		1
7	JWBS20-49	Key	7 x 7 x 25	1
8	TS-0680021	Flat Washer	1/4	15
9	VB-B42	V-Belt		1
10	JWBS20-532	Lower Wheel		1
11	JWBS20-21	Tire		1
12	TS-0680091	Flat Washer	3/4	1
13	JWBS20-22	Hex Nut	3/4-16UNF L.H.	1
14	JWBS20-214	Hex Nut	3/4-16UNF R.H.	1
15	JWBS20-215	Bearing Cover		1
16	TS-0720071	Lock Washer	1/4	3
17	JWBS20-217	Screw	1/4 x 3/8	3
18	JWBS20-218-1	Motor	2HP, 1Ph, 230V Only	1
	JWBS20-218B	Start Capacitor (not shown)		1
	JWBS20-218C	Run Capacitor (not shown)		1
	JWBS20-218D	Capacitor Cover (not shown)		1
	JWBS20-218E	Fan (not shown)		1
	JWBS20-218F	Fan Cover (not shown)		1
	JWBS20-218G	Centrifugal Switch (not shown)		1
19	JWBS18-219	Motor Bracket		1
20	TS-0081031	Hex Cap Bolt	5/16 x 3/4	4
21	TS-0680031	Flat Washer	5/16	4
22	TS-0060051	Hex Cap Bolt	3/8-16 x 1	2
23	TS-0720091	Lock Washer	3/8	2
24	TS-0680041	Flat Washer	3/8	2
25	JWBS20-225	Motor Pulley		1
26	TS-0267041	Set Screw	1/4-20 x 3/8	2
27	JWBS20-227	Lower Front Door		1
28	JWBS20-542	Door Stud		1
29	TS-0561011	Hex Nut	1/4-20	1
30	JWBS20-2	Lock Knob		1
31	JWBS20-3	Screw	1/4 x 3/4	1
32	JWBS20-8	Dust Chute		1
33	TS-0680031	Flat Washer	5/16	2
34	TS-0051051	Hex Cap Bolt	5/16-18 x 1	2
35	JWBS18-235	Cord Plate		1
36	JWBS18-236	Screw	3/16 x 1/2	2
37	JWBS18-237	Strain Relief Bushing		2
38	JWBS18-238	Screw	3/16 x 1-1/2	2
39	TS-0680011	Flat Washer	3/16	2
40	JWBS18-240	Brush		1
41	JWBS18-241	Lock Washer	3/16	2
42	JWBS18-242	Hex Nut	3/16	2
43	JWBS20-243	Motor Cord	1Ph	1
44	JWBS20-244	Power Cord	1Ph	1
45	JWBS20-81	Brake Band		1
46	JWBS20-93	Brake Belt		1
47	TS-0561011	Hex Nut	1/4-20	11
48	JWBS20-248	Hex Nut	M4	2
49	TS-0060111	Hex Cap Bolt	3/8-16 x 2-1/2	1
50	JWBS20-88	Brake Switch		1

Index No.	Part No.	Description	Size	Qty.
51	JWBS20-84	Spring		1
52	JWBS24-81A	Plate		2
53	JWBS20-82	Brake Locking Bracket		2
54	JWBS20-254	Brake Pedal		1
55	TS-0207061	Socket Head Cap Screw	1/4-20 x 1	1
56	TS-0561031	Hex Nut	3/8-16	1
57	JWBS20-257	Hex Cap Bolt	3/8 x 1-3/4	1
58	JWBS20-258	Spindle Pulley		1
59	TS-0050021	Hex Cap Bolt	1/4-20 x 5/8	2
60	JWBS20-260	Screw	3/16 x 1/2	4
61	JWBS20-261	Washer	3/16	4
62	JWBS20-262	Hex Nut	3/16	6
63	TS-0561031	Hex Nut	3/8	2

Blade Guides Assembly

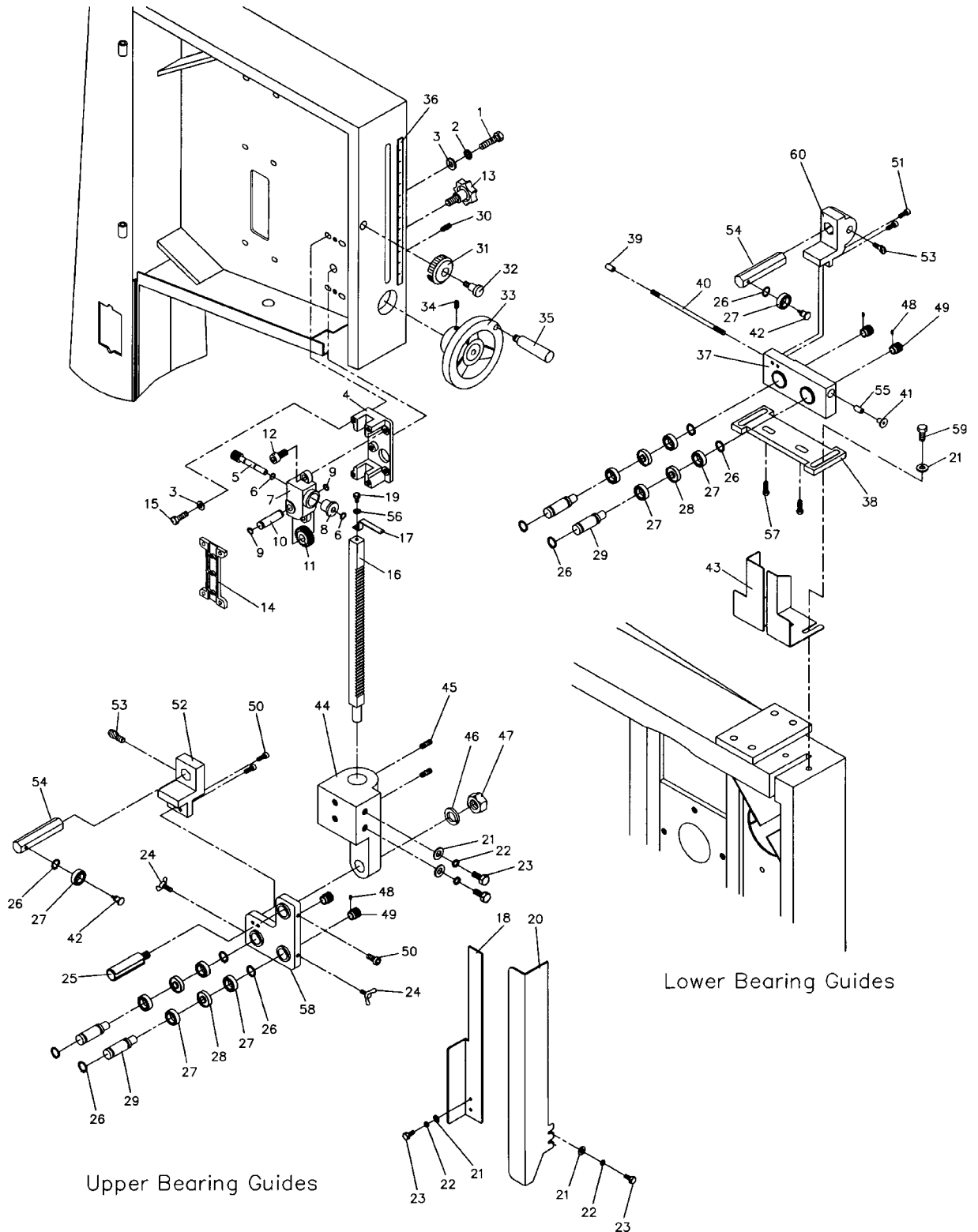

Blade Guides Assembly

Index No.	Part No.	Description	Size	Qty.
1	TS-0051051	Hex Cap Bolt	5/16-18 x 1	4
2	TS-0720081	Lock Washer	5/16	4
3	TS-0680031	Flat Washer	5/16	8
4	JWBS20-304	Guide Bar Bracket		1
5	JWBS18-305	Worm		1
6	JWBS18-306	E-Ring	E-8	2
7	JWBS18-307	Gear Base		1
8	JWBS18-308	Bushing		1
9	JWBS18-309	C-Ring	S-12	2
10	JWBS18-310	Shaft		1
11	JWBS18-311	Gear		1
12	TS-0208071	Socket Head Cap Screw	5/16-18 x 1-1/4	2
13	JWBS20-313	Lock Knob	5/16	1
14	JWBS20-314	Plate		1
15	TS-0051011	Hex Cap Bolt	5/16-18 x 1/2	4
16	JWBS20-316	Guide Bar		1
17	JWBS20-317	Pointer		1
18	JWBS20-318	Inner Blade Guard		1
19	TS-0050011	Hex Cap Bolt	1/4-20 x 1/2	1
20	JWBS20-320	Blade Guard		1
21	TS-0680021	Flat Washer	1/4	6
22	TS-0720071	Lock Washer	1/4	4
23	TS-0050021	Hex Cap Bolt	1/4-20 x 5/8	4
24	JWBS20-324	Wing Bolt		2
25	JWBS20-325	Bracket Shaft		1
26	JWBS20-326	C-Ring		10
27	BB-6202ZZ	Ball Bearing	6202	10
28	JWBS20-328	Spacer		4
29	JWBS20-329	Shaft		4
30	TS-0267041	Set Screw	1/4-20 x 3/8	2
31	JWBS20-2	Lock Knob		1
32	JWBS20-3	Screw	1/4 x 3/4	1
33	JWBS18-333	Hand Wheel		1
34	TS-0267041	Set Screw	1/4-20 x 3/8	1
35	JWBS18-335	Handle		1
36	JWBS20-336	Cutting Height Scale		1
37	JWBS20-337	Bracket		1
38	JWBS20-338	Base		1
39	JWBS20-339	Threaded Lock Bushing		1
40	JWBS20-340	Bolt		1
41	JWBS20-341	Lock Knob		1
42	JWBS20-342	Screw		2
43	JWBS18-343	Lower Blade Guard		1
44	JWBS20-344	Guide Bar Bracket		1
45	JWBS20-345	Set Screw	5/16 x 3/8	2
46	TS-0720111	Lock Washer	1/2	1
47	TS-0561051	Hex Nut	1/2	1
48	JWBS20-348	Set Screw	M4 x 4	8
49	JWBS20-349	Thumb Screw		4
50	TS-0207031	Socket Head Cap Screw	1/4-20 x 5/8	3
51	TS-0207021	Socket Head Cap Screw	1/4-20 x 1/2	2
52	JWBS20-352	Bracket		1
53	JWBS20-353	Thumb Screw	1/4 x 1/2	2
54	JWBS20-354	Bearing Support		2
55	JWBS20-355	Lock Bushing		1

Index No.	Part No.	Description	Size	Qty.
56	TS-0720071	Lock Washer	1/4	1
57	JWBS20-357	Hex Socket Cap Screw	3/16 x 3/8	2
58	JWBS20-358	Bearing Bracket		1
59	TS-0207031	Socket Head Cap Screw	1/4-20 x 5/8	2
60	JWBS20-360	Bracket		1

Table Assembly

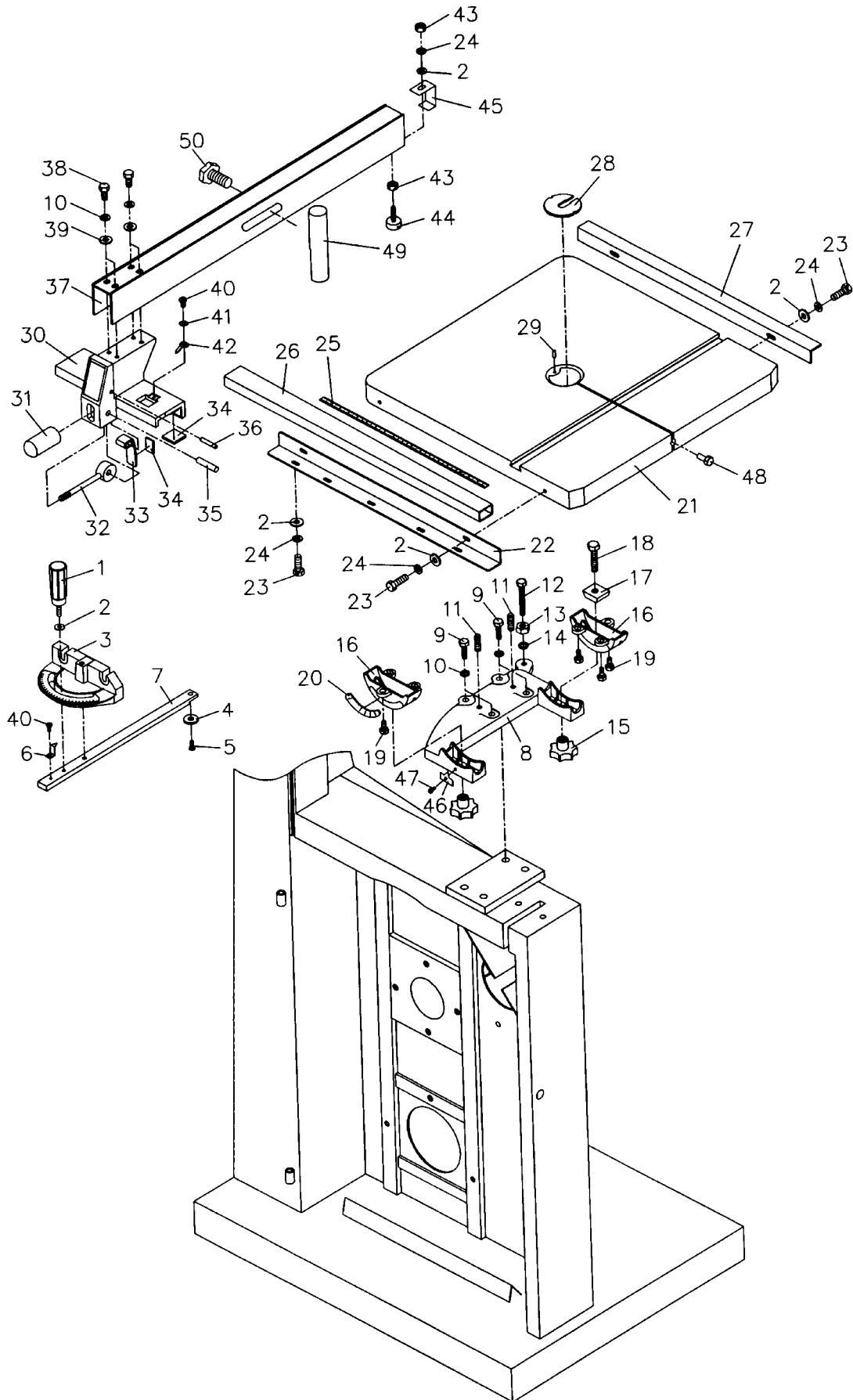
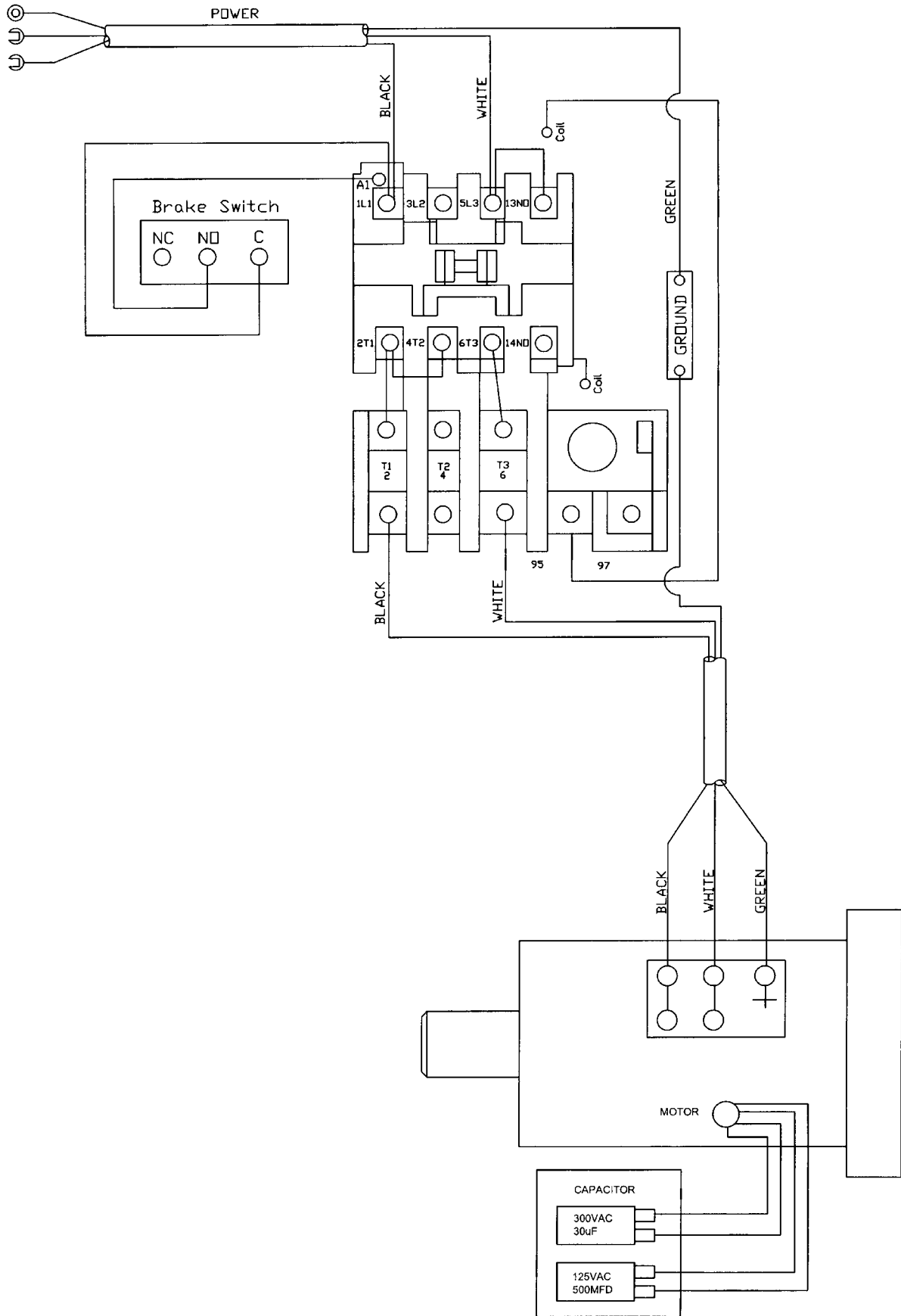

Table Assembly

Index No.	Part No.	Description	Size	Qty.
1	JWBS18-401	Locking Handle		1
2	TS-0680021	Flat Washer	1/4	11
3	JWBS18-403	Miter Gauge Body		1
4	JWBS20-156	Guide Disc		1
5	JWBS18-405	Pan Head Screw	M6 x 8	1
6	JWBS18-406	Pointer		1
7	JWBS18-407	Guide Bar		1
8	JWBS18-408N	Trunnion Support Bracket		1
9	TS-0051071	Hex Cap Bolt	5/16-18 x 1-1/2	4
10	TS-0720081	Lock Washer	5/16	8
11	TS-0270061	Set Screw	5/16-18 x 5/8	2
12	TS-0060111	Hex Cap Bolt	3/8-16 x 2-1/2	1
13	TS-0561031	Hex Nut	3/8	1
14	TS-0720091	Lock Washer	3/8	1
15	JWBS18-415	Lock Knob		2
16	JWBS18-416	Trunnion		2
17	JWBS18-417	Trunnion Clamp Shoe		2
18	TS-1491081	Hex Cap Bolt	M10 x 50	2
19	TS-0207011	Socket Head Cap Screw	M6 x 12	6
20	JWBS18-420	Scale		1
21	JWBS20-421	Table		1
22	JWBS18-422W	Front Rail		1
23	TS-0050021	Hex Cap Bolt	1/4-20 x 5/8	9
24	TS-0720071	Lock Washer	1/4	10
25	JWBS18-425	Scale		1
26	JWBS20-426	Guide Rail		1
27	JWBS18-427W	Rear Rail		1
28	JWBS20-144	Table Insert		1
29	JWBS20-145	Roll Pin	3 x 10	1
30	JWBS18-430	Fence Body		1
31	JWBS18-431	Handle		1
32	JWBS18-432	Cam		1
33	JWBS18-433W	Lock Plate		1
34	JWBS18-434	Pad		5
35	JWBS18-435	Pin		1
36	JWBS18-436	Pin		1
37	JWBS20-437	Fence		1
38	TS-0081031	Hex Cap Bolt	5/16 x 3/4	4
39	JWBS18-439	Flat Washer	5/16	4
40	JWBS18-440	Screw	3/16 x 1/4	2
41	JWBS18-441	Star Washer	3/16	1
42	JWBS18-442	Pointer		1
43	TS-0561011	Hex Nut	1/4	2
44	JWBS18-444	Sliding Pad		1
45	JWBS18-445	Rear Hook		1
46	JWBS18-446	Pointer		1
47	JWBS18-447	Screw	M5 x 8	1
48	JWBS18-448	Table Pin		1
49	JWBS20-449	Resaw Guide		1
50	JWBS20-450	Lock Knob		1
	JWBS18-MGCP	Miter Gauge Assembly		1
	JWBS20-FCPW	Fence Assembly		1

Electrical Schematic - 230V, 1 Ph



Free Manuals Download Website

<http://myh66.com>

<http://usermanuals.us>

<http://www.somanuals.com>

<http://www.4manuals.cc>

<http://www.manual-lib.com>

<http://www.404manual.com>

<http://www.luxmanual.com>

<http://aubethermostatmanual.com>

Golf course search by state

<http://golfingnear.com>

Email search by domain

<http://emailbydomain.com>

Auto manuals search

<http://auto.somanuals.com>

TV manuals search

<http://tv.somanuals.com>