

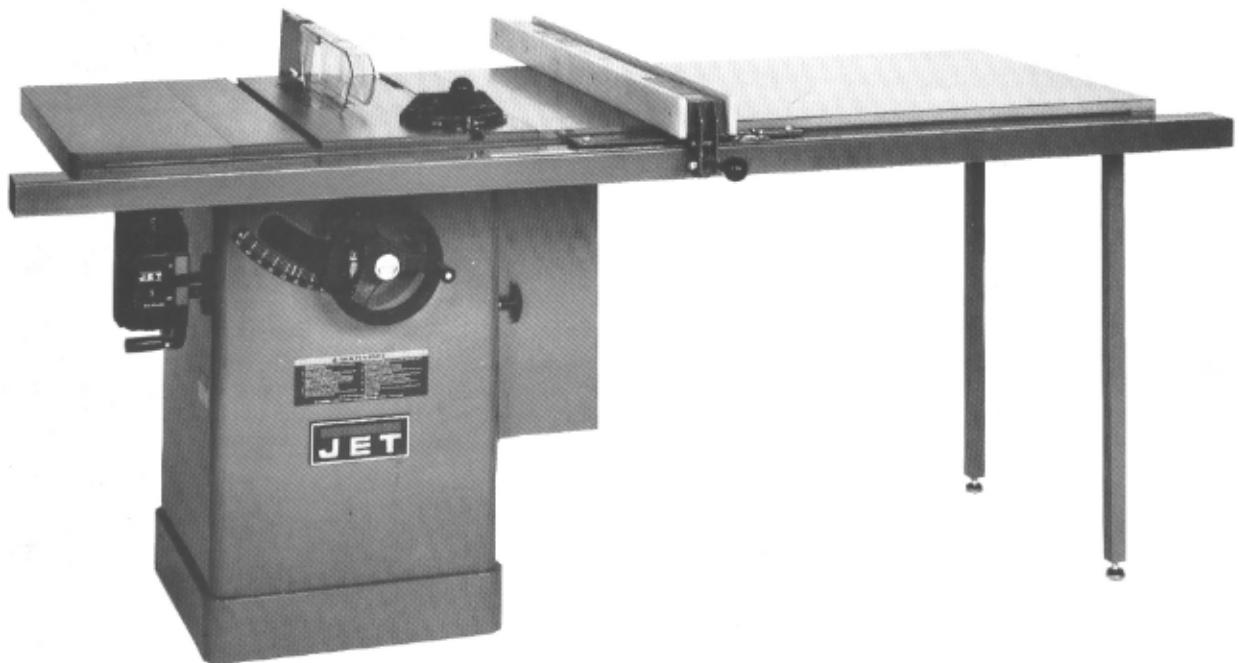

OPERATOR'S MANUAL

JTAS-10 / JTAS-12 Tilting Arbor Tablesaw



(JTAS-10 shown w/ optional JET XACTA Fence, extension table, and support legs)

JET EQUIPMENT & TOOLS, INC.
A WMH - Walter Meier Holding Company

P.O. BOX 1349
Auburn, WA 98071-1349

253-351-6000
Fax 253-939-8001

No. M-708510 4/02

Important Information

**2-YEAR
LIMITED WARRANTY**

**JET offers a two-year limited
warranty on this product**

REPLACEMENT PARTS

Replacement parts for this tool are available directly from JET Equipment & Tools. To place an order, call 1-800-274-6848. Please have the following information ready:

1. Visa, MasterCard, or Discover Card number
2. Expiration date
3. Part number listed within this manual
4. Shipping address other than a Post Office box.

REPLACEMENT PART WARRANTY

JET Equipment & Tools makes every effort to assure that parts meet high quality and durability standards and warrants to the original retail consumer/purchaser of our parts that each such part(s) to be free from defects in materials and workmanship for a period of thirty (30) days from the date of purchase.

PROOF OF PURCHASE

Please retain your dated sales receipt as proof of purchase to validate the warranty period.

LIMITED TOOL AND EQUIPMENT WARRANTY

JET makes every effort to assure that its products meet high quality and durability standards and warrants to the original retail consumer/purchaser of our products that each product be free from defects in materials and workmanship as follows: **2 YEAR LIMITED WARRANTY ON THIS JET PRODUCT.** Warranty does not apply to defects due directly or indirectly to misuse, abuse, negligence or accidents, repairs or alterations outside our facilities or to a lack of maintenance. **JET LIMITS ALL IMPLIED WARRANTIES TO THE PERIOD SPECIFIED ABOVE FROM THE DATE THE PRODUCT WAS PURCHASED AT RETAIL. EXCEPT AS STATED HEREIN, ANY IMPLIED WARRANTIES OR MERCHANTABILITY AND FITNESS ARE EXCLUDED. SOME STATES DO NOT ALLOW LIMITATIONS ON HOW LONG THE IMPLIED WARRANTY LASTS, SO THE ABOVE LIMITATION MAY NOT APPLY TO YOU. JET SHALL IN NO EVENT BE LIABLE FOR DEATH, INJURIES TO PERSONS OR PROPERTY OR FOR INCIDENTAL, CONTINGENT, SPECIAL OR CONSEQUENTIAL DAMAGES ARISING FROM THE USE OF OUR PRODUCTS. SOME STATES DO NOT ALLOW THE EXCLUSION OR LIMITATION OF INCIDENTAL OR CONSEQUENTIAL DAMAGES, SO THE ABOVE LIMITATION OR EXCLUSION MAY NOT APPLY TO YOU.** To take advantage of this warranty, the product or part must be returned for examination, postage prepaid, to an authorized service station designated by our Auburn office. Proof of purchase date and an explanation of the complaint must accompany the merchandise. If our inspection discloses a defect, JET will either repair or replace the product or refund the purchase price, if we cannot readily and quickly provide a repair or replacement, if you are willing to accept such refund. JET will return repaired product or replacement at JET's expense, but if it is determined there is no defect, or that the defect resulted from causes not within the scope of JET's warranty, then the user must bear the cost of storing and returning the product. This warranty gives you specific legal rights, and you have other rights, which vary, from state to state.

JET Equipment & Tools • P.O. Box 1349, Auburn, WA 98071-1349 • (253) 351-6000

WARNING

- **Read and understand the entire instruction manual before attempting assembly or operation.**
- **This tablesaw is designed and intended for use by properly trained and experienced personnel only. If you are not familiar with the proper and safe operation of a tablesaw, do not use until proper training and knowledge has been obtained.**
- Always wear approved safety glasses/face shields while using this tablesaw.
- Make certain the tablesaw is properly grounded.
- Before operating the tablesaw, remove tie, rings, watches, other jewelry, and roll up sleeves above the elbows. Remove all loose clothing and confine long hair. Do **not** wear gloves.
- Keep the floor around the tablesaw clean and free of scrap material, oil and grease.
- Keep the tablesaw guards in place at all times when the tablesaw is in use. If removed for maintenance purposes, use extreme caution and replace the guards immediately.
- Do **not** over reach. Maintain a balanced stance at all times so that you do not fall or lean against blades or other moving parts.
- Make all tablesaw adjustments or maintenance with the tablesaw unplugged from the power source.
- Use the right tool. Don't force a tool or attachment to do a job that it was not designed for.
- Replace warning labels if they become obscured or removed.
- Make certain the motor switch is in the **OFF** position before connecting the tablesaw to the power supply.
- Give your work undivided attention. Looking around, carrying on a conversation, and "horse-play" are careless acts that can result in serious injury.
- Keep visitors a safe distance from the work area.
- Use recommended accessories; improper accessories may be hazardous.
- Never place hands directly in line with the saw blade.
- Always use push sticks when cutting small material.
- Raise or lower the blade only when the tablesaw has been turned off and the blade has come to a complete stop.
- Read and understand warnings posted on the tablesaw.
- Use blade guard for every applicable operation including all through cuts. If the guard is removed for special non-through cuts such as dado and rabbet cuts, replace before further use of the tablesaw.
- Failure to comply with all of these warnings may cause serious injury.
- **WARNING:** Some dust created by power sanding, sawing, grinding, drilling and other construction activities contains chemicals known to cause cancer, birth defects of other reproductive harm. Some examples of these chemicals are:
 - Lead from lead based paint
 - crystalline silica from bricks and cement and other masonry products, and
 - arsenic and chromium from chemically-treated lumber.
- Your risk from those exposures varies, depending on how often you do this type of work. To reduce your exposure to these chemicals: work in a well ventilated area, and work with approved safety equipment, such as those dust masks that are specifically designed to filter out microscopic particles

Introduction

The JET JTAS-10 or JTAS-12 tablesaw you have purchased is a high quality machine tool that will give you years of superior service. You will get maximum performance and enjoyment from your new table saw if you will take a few moments now to review the entire manual before beginning assembly and operation.

The JET JTAS-10 and JTAS-12, as well as all JET products, are backed by a nationwide network of authorized distributors and/or service centers. Please contact your nearest distributor should you require parts or service. Parts are also available directly from JET by calling 1-800-274-6844.

Now that you have purchased a tablesaw, it is a good time to consider a dust collection system. See your local JET distributor for the complete line of dust collectors and the full line of JET Dust Collector Hoses and Accessories. Customize your installation and obtain maximum performance with JET's dust hoods, hoses, clamps, fittings, and blast gates.

Table of Contents

Warnings.....	1
Introduction.....	2
Table of Contents.....	2
Specifications.....	3
Contents of the Shipping Container.....	4
Tools Required for Assembly.....	4
Unpacking and Cleanup.....	4
Installation and Leveling.....	5
Motor Cover Assembly.....	5
Extension Wing Assembly.....	5
Attaching Switch Bracket and Switch Brace to Saw.....	6
Blade Guard Assembly.....	7
Installing Blade.....	7
Aligning Blade Guard and Splitter.....	8
Hand Wheel Assembly.....	8
Table Insert Adjustment.....	8
Electrical Connections.....	9
Miter Gauge Operation.....	9
Blade Raising and Tilting Mechanism.....	10
Blade Alignment.....	10
Adjusting 45° and 90° Positive Stops.....	11
Troubleshooting.....	12-13
Parts Breakdown and Parts Lists.....	14-21
Electrical Schematic.....	22-23

Specifications

JTAS-10

Stock Number	708510 (3HP, 1 Ph)
.....	708540 (5HP, 1Ph)
.....	708530 (5 HP, 3 Ph)
Blade Diameter	10"
Arbor Diameter.....	5/8"
Maximum Depth of Cut.....	3"
Maximum Thickness at 45° Cut.....	2-1/8"
Table in Front of Saw Blade at Maximum Cut.....	12"
Maximum Width of Dado.....	13/16"
Maximum Diameter of Dado	8" with no clearance insert
Dust Port Diameter	4"
Table Height.....	34"
Table Size (with extension).....	27"D x 40"W
Table Size (without extension).....	27" D x 20"W
Arbor Speed.....	4,200 RPM
Motor.....	3HP, 1Ph, 230V only
.....	5HP, 1 Ph, 230V only
or	5HP, 3Ph, 230/460V, prewired 230V
Net Weight (approx.).....	352 lbs.

Specifications

JTAS-12

Stock Number	708536 (5HP, 1 Ph)
.....	708541 (5HP, 3 Ph)
Blade Diameter	12"
Arbor Diameter.....	1"
Maximum Depth of Cut.....	4"
Maximum Thickness at 45° Cut.....	2-7/8"
Table in Front of Saw Blade at Maximum Cut.....	12"
Maximum Width of Dado.....	13/16"
Maximum Diameter of Dado	8"
Dust Port Diameter	4"
Table Height.....	33-7/8"
Table Size (with extension).....	29"D x 44"W
Table Size (without extension).....	29" D x 22"W
Arbor Speed.....	4,200 RPM
Motor.....	5HP, 1Ph, 230V only
or	5HP, 3Ph, 230/460V, prewired 230V
Net Weight (approx.).....	396 lbs.

The JTAS-10 and JTAS-12 Tilting Arbor tablesaws are designed to allow the use of several precision fences by various manufacturers. Please follow the directions for mounting the fence and rails that come with the fence system you have purchased.

The specifications in this manual are given as general information and are not binding. JET Equipment and Tools reserves the right to effect, at any time and without prior notice, changes or alterations to parts, fittings, and accessory equipment deemed necessary for any reason whatsoever.

 **WARNING**

Read and understand the entire contents of this manual before attempting assembly or operation!
Failure to comply may cause serious injury!

Contents of the Shipping Container

- 1 Saw
- 1 Motor Cover
- 2 Extension Wing

Accessory Package:

- 1 Blade Guard Assembly
- 1 Hand Wheel / Handle Assembly
- 1 Lock Knob
- 1 Arbor Wrench
- 1 Miter Gauge Assembly
- 1 Blade Guard Wrench w/ Cable
- 1 Switch Brace
- 1 8mm Hex Wrench

Note: The blade guard wrench attached to the blade guard shaft with a cable is included for your convenience. Install the blade guard shaft assembly as shipped and the wrench will always be immediately available to adjust, install, or remove the blade guard assembly. **Always use the blade guard whenever possible. If making cuts that require the removal of the blade guard, use extreme caution. Replace the blade guard immediately after finishing those cuts that require its removal.**

Tools Required for Assembly

Metric Wrench Set or 6"-8" Adjustable Wrench
Metric Hex Wrench Set

Unpacking and Clean-Up

- 1. Finish removing all contents from the shipping container. Do not discard any shipping material until the saw is set up and running satisfactorily.
- 2. Inspect contents for shipping damage. Report damage, if any, to your local distributor.
- 3. Compare contents of shipping container with contents list in this manual. Report shortages, if any, to your distributor.
- 4. Remove hex cap bolts, washers, and hex nuts from skid bottom.
- 5. Carefully move saw to its final location.

⚠ WARNING

**Do not connect the tablesaw to the power source until all assembly has been completed!
Failure to comply may cause serious injury!**

Installation and Leveling

Final location for the saw must be level, dry, well lighted, and have enough room to allow movement around the saw with long pieces of wood stock.

Level the saw front to back and side to side using a carpenter's level placed on the table. Use shims under the corners, if necessary, but make sure the saw is stable before being placed into service.

Motor Cover Assembly

1. Remove shipping bracket (A, Fig. 1) holding motor to table.
2. After the shipping bracket has been removed, install the bolt back into the motor support bracket (B, Fig. 1). The other bolt is used to hold the extension wing in place.
3. Remove remaining two hex cap bolts, lock washers, and flat washers in the table edge.
4. Install motor cover by aligning pins on cover with brackets on pedestal.
5. Fasten cover by pulling out latch (A, Fig. 2), closing the door, and releasing the latch.

Extension Wing Assembly

1. Remove shipping bracket (A, Fig. 3) holding switch assembly to table. Do **not** discard the hardware.
2. Attach extension wings to table with six hex cap bolts previously removed.
3. Slide each extension wing toward the front of the saw until the wing is flush with the table. **If the wing is not flush with the table edge, there is a possibility of distorting the front rail when tightened to the extension wing. This may cause the fence to bind.**
4. Using a straight edge, align the extension wings to the saw table and tighten the hex cap bolts.

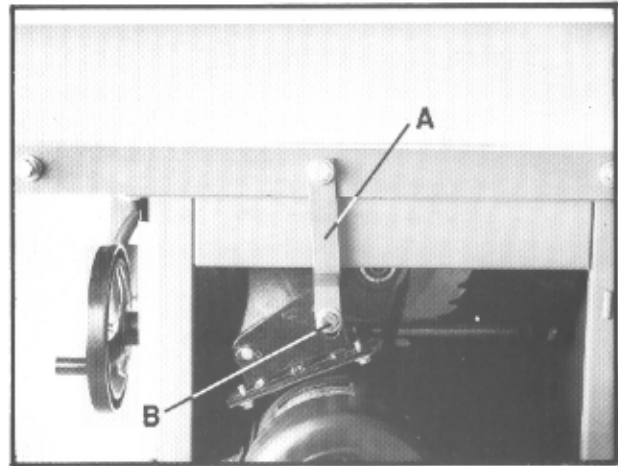

Fig. 1

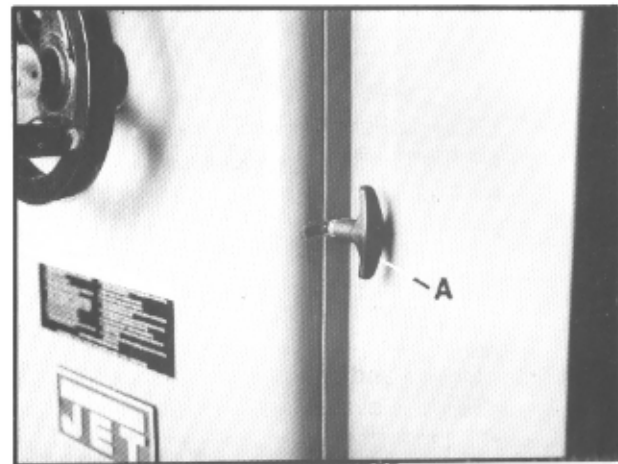

Fig. 2

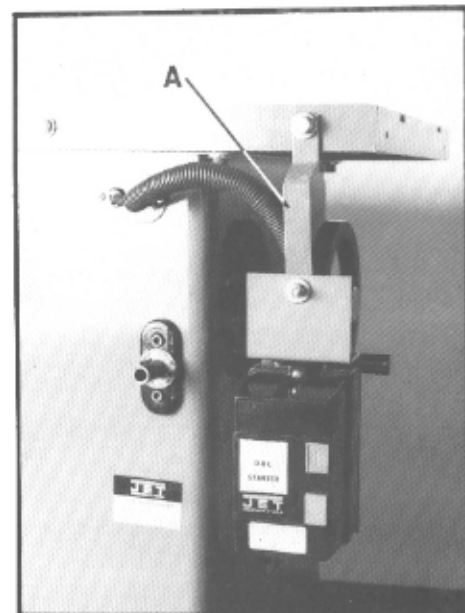

Fig. 3

Attaching the Switch Bracket Assembly and Switch Brace to the Saw

1. Place switch bracket assembly behind both the front fence rail and the lip of the left extension wing. (Do not place between the front fence rail and the extension wing - this will cause the front rail to distort and the fence to bind).
2. Line up the hole in the switch bracket assembly with the hole in the rail and the extension wing.
3. Attach the switch bracket assembly to the rail with one 5/16" x 1-1/4" flat head screw, one 5/16" flat washer, and one 5/16" hex nut found in the fence kit.
4. Loosen (do not remove) hex socket cap screw (A, Fig. 3-1). Do not remove the table - this is for illustration purposes only.
5. Slide the open tab of the switch brace (D, Fig. 3-1) onto the hex socket cap screw and washer and hand tighten.
6. Remove the nut (B, Fig. 3-1) and star washer (C, Fig. 3-1) from the screw at the bottom of the switch plate.
7. Fasten the switch brace to the switch bracket assembly with the star washer and nut. Remove the switch box cover and hold the screw from the other side, if necessary.
8. Carefully replace the switch box cover, if necessary. Make sure all wires are inside the box. Do not force the box closed.
9. Align the switch and tighten all hardware firmly.
10. When completed, the switch brace and switch bracket should look like Fig. 3-2.

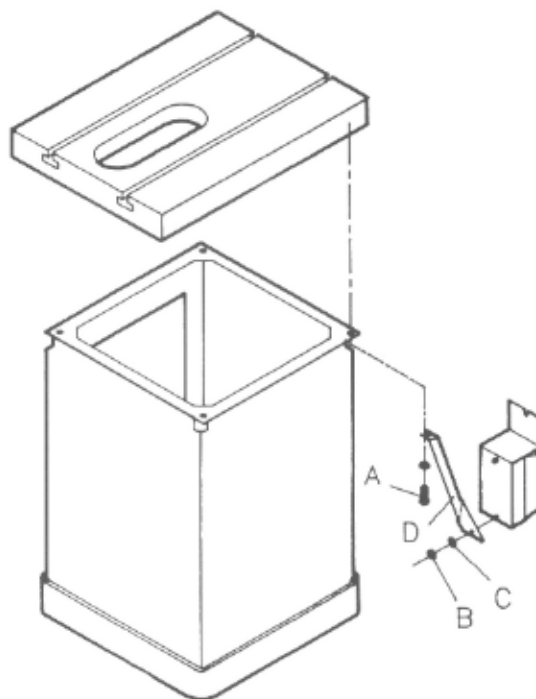

Fig. 3-1

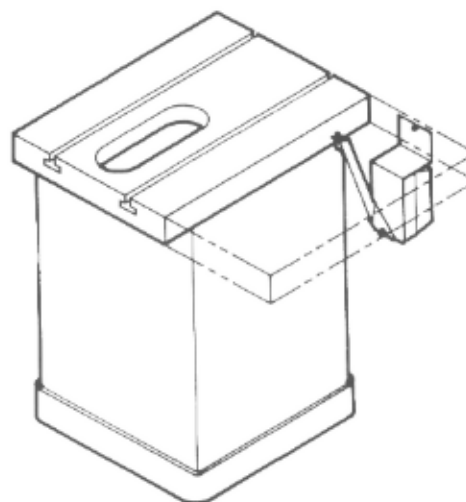

Fig. 3-2

Blade Guard Assembly

1. Place a 5/8" lock washer onto the threaded portion of the blade guard shaft.
2. Thread blade guard shaft into rear trunnion through opening at rear of saw. (Fig. 4).
3. Tighten blade guard shaft. The blade guard post has a flat detent to accommodate a wrench.
4. Place upper and lower bracket assembly in the upright position and tighten two set screws (A, Fig. 4) just enough to hold in place. Do not tighten firmly at this time.
5. Insert front tab of blade guard assembly through insert opening in table and onto bracket assembly. Tab fits between bracket assembly (A, Fig. 5) and flat washer (B, Fig. 5).
6. Hold rear tab (A, Fig. 6) of blade guard assembly to the upper blade guard bracket (B, Fig. 6) with two hex cap bolts (C, Fig. 6), and a plate. Finger tighten only at this time.
7. Blade will need to be installed, if not installed already, before final adjustment can be made.

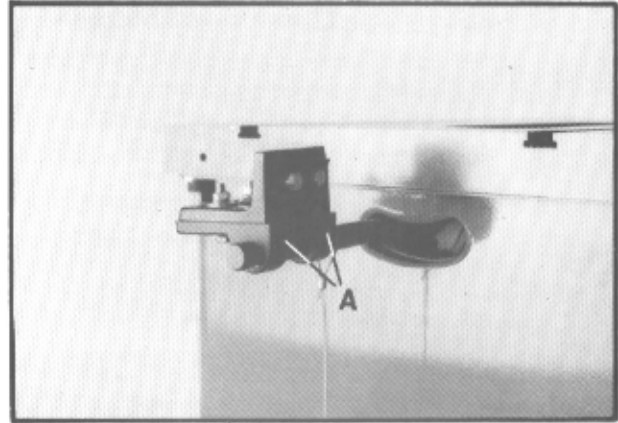

Fig. 4

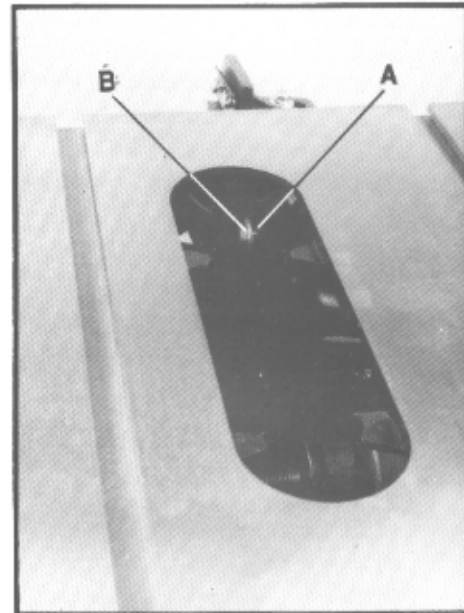

Fig. 5

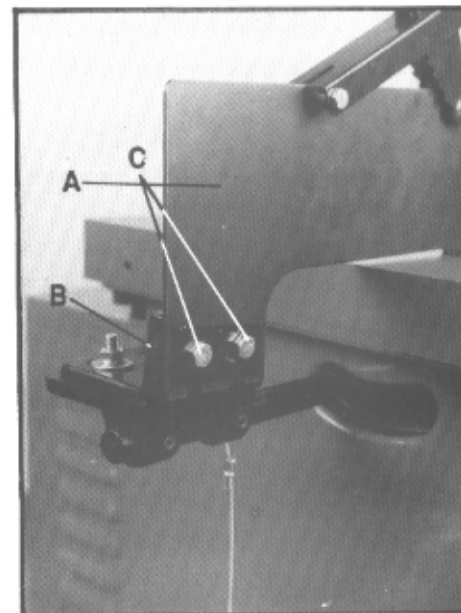

Fig. 6

Installing Blade

WARNING

**When installing or changing saw blade, always disconnect saw from the power source!
Failure to comply may cause serious injury!**

1. Raise the blade arbor fully and lock the saw at zero by tightening the lock knob in the middle of the handwheel.
 2. Remove the arbor nut and flange.
- Note:** Nut has left hand thread; turn clockwise to remove.
3. Place the blade on the arbor shaft making sure the teeth point down at the front of the saw. Replace the flange and the arbor nut.
 4. Place a wood scrap in the blade's teeth at the rear of the machine. Hold the block of wood in such a way that if it slips or the blade turns, your hand will not contact the blade.
 5. Using the wrench provided, securely tighten the arbor nut. Remove the wrench.

Aligning Blade Guard and Splitter

1. Raise blade guard away from table and hold anti-kickback pawls away from table surface with the cut-out in the guard arm. (Fig. 7)
 2. Using an accurate straight edge (A, Fig. 7), align the splitter with the saw blade.
- Note:** Be sure that straight edge rests against body of saw blade and not saw teeth.
3. When saw blade is aligned with the splitter, carefully tighten the hex cap bolt on the bracket assembly inside the saw.
 4. Make sure the splitter is level with the table and approximately 1/8" above the table before tightening the hardware on the rear of the blade guard assembly. Space between the splitter and the table keeps the splitter from binding on the table when the blade is tilted to 45°.
 5. Check alignment again after tightening hardware. Realign if necessary.

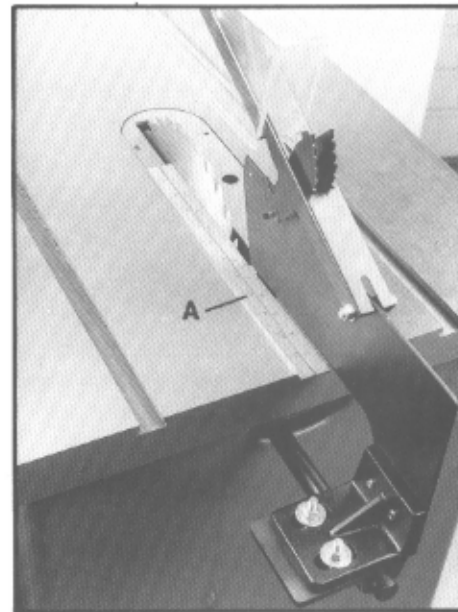

Fig. 7

Hand Wheel Assembly

1. Attach handle (A, Fig. 8) to hand wheel (B, Fig. 8).
2. Tighten lock nut to prevent the handle from coming out.
3. Slide handwheel assembly onto the shaft.
4. Tighten the set screw on the handwheel hub securely.
5. Install center lock knob (C, Fig. 8) by inserting into the center hole in the shaft and threading in a clockwise direction.

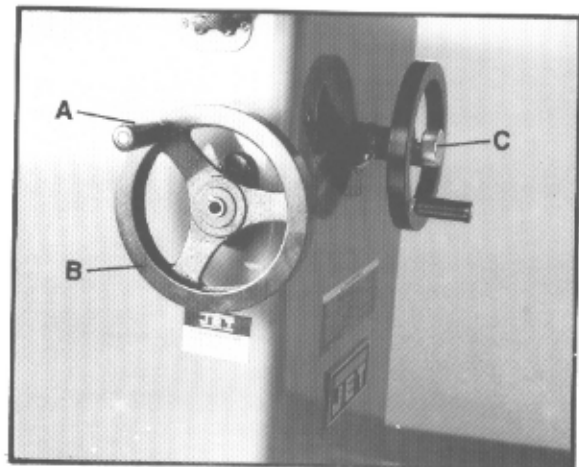

Fig. 8

Table Insert Adjustment

1. Lower blade completely.
2. Place the open end of the insert under the splitter and lower the insert into the opening. If you have difficulty placing the insert, the blade guard assembly will have to be raised.
3. Adjust the table insert flush with the table by turning four leveling screws and using a straight edge.

Electrical Connections

⚠ WARNING!

**All electrical connections must be completed by a qualified electrician!
Failure to comply may result in serious injury!**

The JTAS-10 table saw is rated at 3 HP, 1Ph, 230V, 5 HP, 1 Ph, 230V, or 5 HP, 3Ph, 230/460V. The JTAS-12 is rated at 5HP, 1Ph, 230V or 5 HP, 3Ph, 230/460V. Both saws come pre-wired from the factory at 230V.

To switch the JTAS-10/12 from 230V to 460V:

1. **Disconnect the machine from the power source. (unplug)**
2. Open the saw cabinet door.
3. Remove the cover from the motor junction box.
4. Change wires following the diagram on the inside of the cover.
5. Replace the cover and close the cabinet door.
6. Replace the magnetic on-off switch with part #JTAS10-23B. This switch is available through your authorized JET distributor or by calling JET at 1-800-274-6844.

Confirm power at the site is the same as the saw before making any electrical connections. Review the electrical schematics on page 22-23.

The on and off switch is **thermally protected**. If the saw motor is overloaded or a momentary interruption of electrical current is sensed, the saw will shut off. Allow a few minutes for the saw to cool down and reset by **pushing the off button**.

Miter Gauge Operation

1. Operate miter gauge by loosening lock knob (A, Fig. 9) and turning miter body (B, Fig. 9) to desired angle. To move gauge beyond index stops of 45° and 90°, flip down stoplink (C, Fig. 9).
2. Adjust index stops by turning one of three adjustment screws (D, Fig. 9).

Note: Always make test cuts. Do not rely solely on the miter gauge indicator marks.

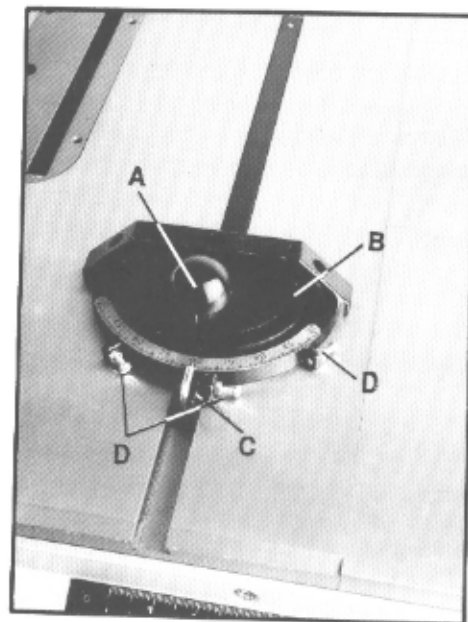

Fig. 9

Blade Raising and Tilting Mechanism

1. To raise or lower the saw blade, loosen the lock knob in the middle of the handwheel and turn the handwheel on the saw front until desired height is reached. Tighten lock knob. The blade should be adjusted 1/8" to 1/4" above the top surface of the material being cut.
2. To tilt the saw blade, loosen lock knob, turn handwheel on the left of the saw cabinet until desired angle is obtained, then tighten lock knob.

Blade Alignment

Blade alignment with the table is adjusted at the factory. After a period of use, or, after moving the saw to another location, the blade may no longer be aligned with the table. To check and align the blade:

1. **Disconnect the saw from the power source.**
2. Raise the blade guard up and out of the way of the blade.
3. Unlock fence and move away from the blade so as to expose the right T-slot.
4. Measure the distance from the back edge of the blade to the right T-slot edge.
5. Rotate blade toward the front.
6. Measure the distance from the front edge of the blade at the same location on the blade to the right T-slot edge. The two measurements should be the same.
7. If they are not the same, loosen four hex socket cap screws (A, Fig. 10) that hold the table to the base. (Two are shown in A, Fig. 10)
8. Move the table until the measurements from the front edge of the blade to the miter slot and the back edge of the blade to the miter slot are the same. It is important to use the same location on the blade.
9. Tighten the four hex socket cap screws firmly.

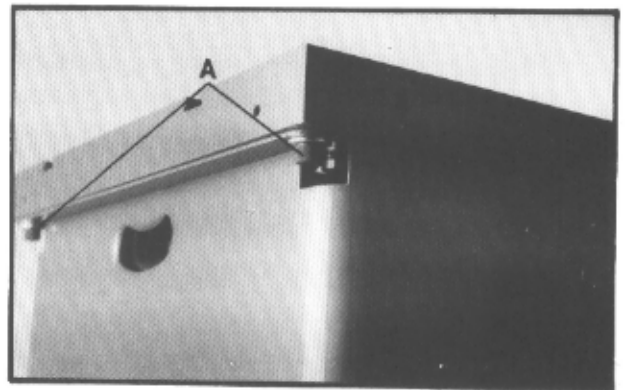

Fig. 10

Adjusting 45° and 90° Positive Stops

1. Disconnect saw from power source.
2. Raise the saw blade to its maximum height using the handwheel.
3. Set the blade at 90 degrees to the table by turning the blade tilting handwheel clockwise as far as it will go.
4. Place a square on the table and check to see that the blade is at a 90° angle to the table. (Fig. 11) Make sure square is not touching a blade tooth.
5. If blade is not at 90 degrees, open the motor cover door, loosen lock nut (A, Fig. 12) and turn adjusting stop screw (B, Fig. 12) on the front trunnion (C, Fig. 12) in or out. The adjusting stop screw (B, Fig. 12) should stop against the front trunnion bracket when the blade is 90° to the table.
6. Tighten the lock nut (A, Fig. 12).
7. Place a square on the table after turning the blade to the 45° stop (Fig. 13). If the 45° positive stop is not set properly, follow the same procedure using lock nut (D, Fig. 12) and screw (E, Fig. 12).
8. Check the accuracy of the pointer on the angle scale and adjust, if necessary.

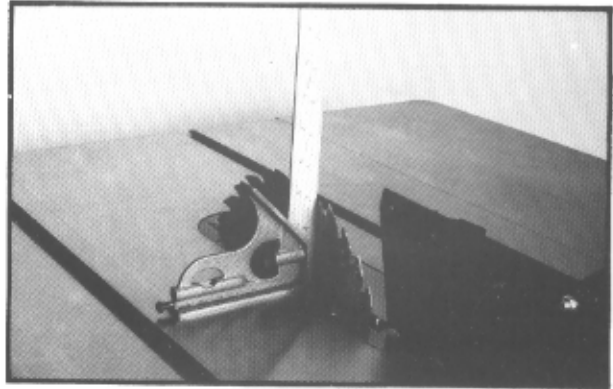

Fig. 11

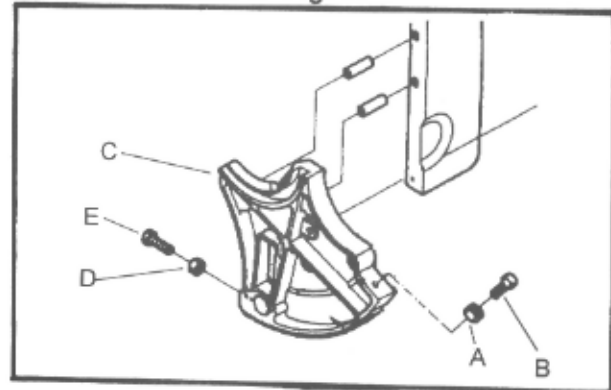

Fig. 12

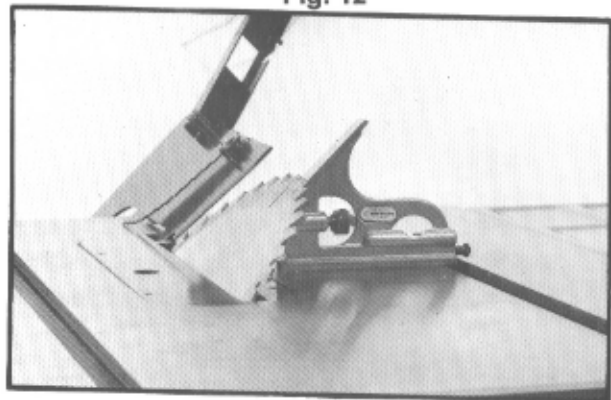

Fig. 13

Assembly and adjustment of the saw are now complete. Make sure all fasteners are tight. The saw may now be placed into operation.

Troubleshooting

Problem

Possible Causes and Solutions:

Saw will not start	<ul style="list-style-type: none">* Saw not connected to the power source Connect saw to the power source* Fuse blown or circuit breaker tripped Replace fuse or reset circuit breaker* Cord damaged from the power source Replace power cord* Off button reset is tripped Depress off button to reset, then start saw
Does not make accurate 45° or 90° rip cuts	<ul style="list-style-type: none">* Positive stops not adjusted correctly Check blade with square and adjust positive stops* Tilt angle pointer not set accurately Check blade with square and adjust pointer to zero
Material binds blade when ripping	<ul style="list-style-type: none">* Rip fence not aligned with blade Check and adjust rip fence* Warped wood Select another piece of wood
Material binds on splitter	<ul style="list-style-type: none">* Splitter not aligned correctly with blade Check and align splitter with blade
Saw makes unsatisfactory cuts	<ul style="list-style-type: none">* Dull blade Sharpen or replace blade* Blade mounted backwards Turn blade around* Gum or pitch on blade Remove blade and clean with turpentine and coarse steel wool* Incorrect blade for cut being made Change blade to correct type* Gum or pitch on table causing erratic feed Clean table with turpentine
Blade does not come up to speed	<ul style="list-style-type: none">* Extension cord too light or too long Replace with adequate size cord* Low shop current Contact your local electrical company* Motor not wired for correct voltage Refer to motor junction box for correct wiring
Saw vibrates excessively	<ul style="list-style-type: none">* Stand on uneven floor Reposition on flat, level surface* Damaged saw blade Replace saw blade* Bad V-belt(s) Replace v-belt(s)

Saw vibrates excessively (cont'd)

- * Improper motor mounting
Check and adjust motor mounting
- * Loose hardware
Tighten all nuts, bolts, and sets screws

Material kicked back from blade

- * Rip fence out of alignment
Align rip fence with miter gauge slot
- * Splitter not aligned with blade
Align splitter with blade
- * Feeding stock without rip fence
Install and use rip fence
- * Splitter not in place
Install and use splitter (with guard)
- * Dull blade
Replace blade
- * Letting go of material before it is past blade
Push material all the way past blade before releasing work

Blade does not raise or tilt freely

- * Sawdust and debris in raising and tilting mechanisms
Brush or blow out dust and debris

Does not make accurate 45° or 90° cross cuts

- * Miter gauge out of adjustment
Adjust miter gauge

Table and Cabinet Assembly

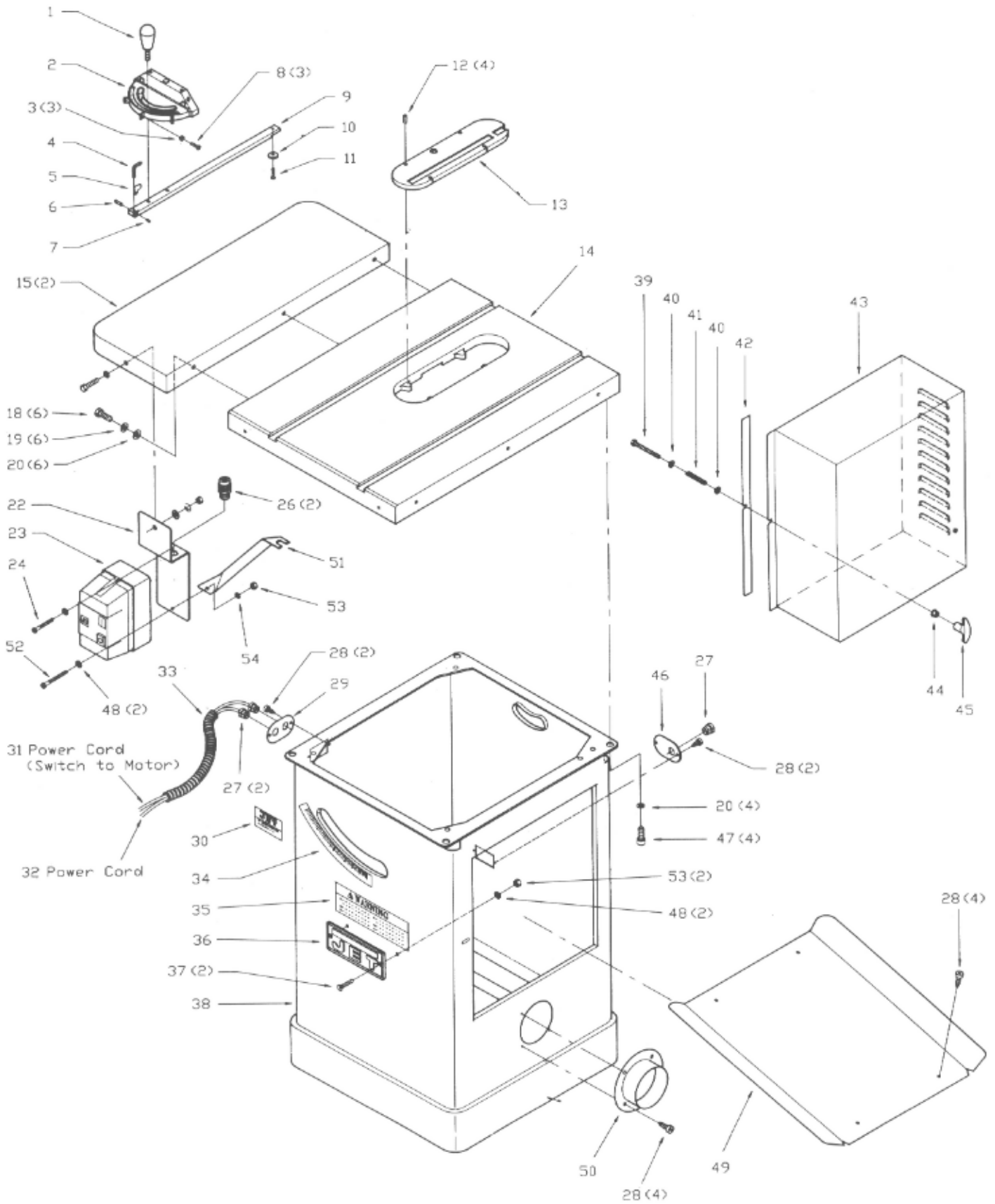

Parts List For The JTAS-10/12 Tilting Arbor Table Saw

Table and Cabinet Assembly

Index No.	Part No.	Description	Size	Qty.
1	JTAS10-1	Lock Knob		1
2	JTAS10-2	Miter Gauge Body		1
3	TS-1540031	Hex Nut	M5	3
4	JTAS10-4	Pointer		1
5	JTAS10-5	Stop Link		1
6	TS-1521011	Set Screw	M4x4	1
7	JTAS10-7	Special Pin	M3x6	1
8	JTAS10-8	Screw	M5x20	1
9	JTAS10-9	Guide Bar		1
10	JTAS10-10	Guide Washer		1
11	JTAS10-11	Flat Head Screw	M6x8	1
	JTAS10-MG	Miter Gauge Assembly (#1-11)		1
12	TS-0267041	Set Screw	1/4x3/8	4
13	JTAS10-13	Table Insert		1
	JTAS12-13	Table Insert		1
14	JTAS10-14 W	Table		1
	JTAS12-14 W	Table		1
15	JTAS10-15 W	Extension Wing		2
	JTAS12-15 W	Extension Wing		2
18	TS-0061051	Hex Socket Cap Screw	7/16x1-1/2	6
19	TS-0720101	Lock Washer	7/16	6
20	TS-0680051	Flat Washer	7/16	6
21	TS-0720081	Lock Washer	5/16	1
22	JTAS10-22 W	Switch Plate		1
23	JTAS10-23	Magnetic Switch	3HP,1Ph,230V	1
	JTAS10-23A	Magnetic Switch	5HP,3Ph,230V	1
	JTAS10-23B	Magnetic Switch	5HP,3Ph,460V	1
	JTAS12-23	Magnetic Switch *	5HP,1Ph,230V	1
24	JTAS10-24	Screw	3/16x3/4	1
26	JTAS10-26	Cord Connector		2
27	JTAS10-27	Cord Clamp		3
	JTAS12-27	Cord Clamp *		3
28	JTAS10-28	Tap Screw	M5x10	12
29	JTAS10-29	Cord Plate		1
	JTAS12-29	Cord Plate *		1
30	JTAS10-30	Identification Plate		1
	JTAS12-30	Identification Plate		1
31	JTAS10-31	Power Cord (switch to motor)		1
	JTAS12-31	Power Cord (switch to motor) *		1
32	JTAS10-32	Power Cord		1
	JTAS12-32	Power Cord *		1
33	JTAS10-33	Power Cord Sleeve		1
	JTAS12-33	Power Cord Sleeve *		1
34	JTAS10-34	Tilt Scale		1
35	JTAS10-35	Warning Label		1
36	JTAS10-36	JET Plaque		1

37	JTAS10-37	Flat Head Screw	3/16x3/8	2
38	JTAS10-38 W	Cabinet		1
	JTAS12-38 W	Cabinet		1
39	TS-1482101	Hex Cap Bolt	M6x50	1
40	TS-0680021	Flat Washer	1/4	2
41	JTAS10-41	Spring		1
42	JTAS10-42	Foam Strip		1
43	JTAS10-43 W	Motor Cover		1
	JTAS12-43 W	Motor Cover		1
44	TS-1540021	Hex Nut	M6	1
45	JTAS10-45	Handle		1
46	JTAS10-47	Cord Clamp Plate		1
	JTAS12-47	Cord Clamp Plate *		1
47	TS-0210011	Hex Socket Cap Screw	7/16x3/4	4
48	TS-0680011	Flat Washer	3/16	4
49	JTAS10-50 W	Lower Panel		1
	JTAS12-50 W	Lower Panel		1
50	JTAS10-51 W	Dust Hose Adapter		1
51	JTAS10-52 W	Switch Brace Kit **		1
	JTAS12-52 W	Switch Brace Kit **		1
52	JTAS10-53	Screw	3/16 x 1	1
53	JTAS10-54	Nut	3/16	3
54	JTAS10-55	Star Washer	3/16	1

* 10" Saws with 5 HP, 1Ph motor uses these parts.

** Switch Brace Kit contains bracket, screw, nut, star washer, and 8mm hex wrench.

Blade Guard Assembly

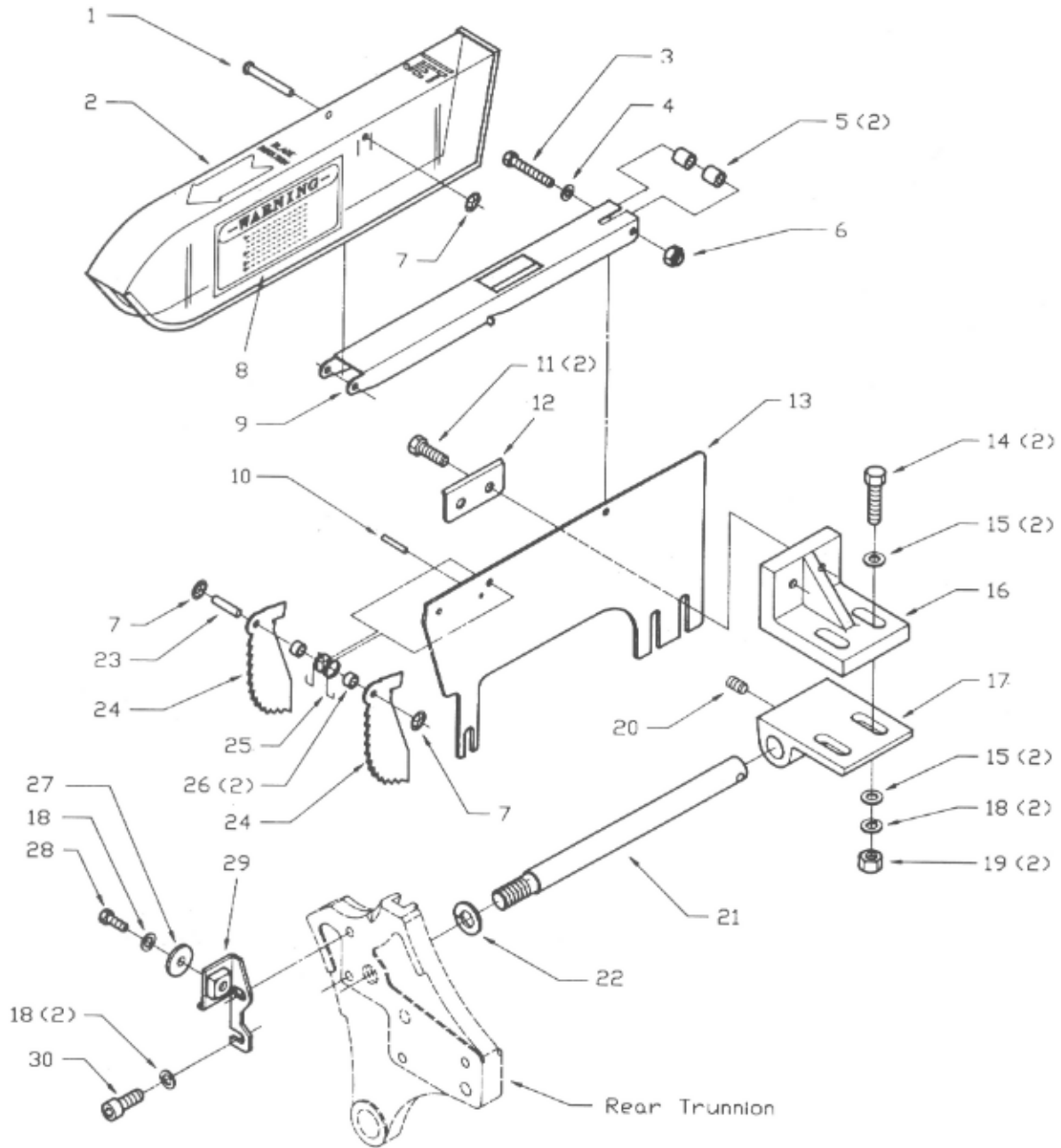

Blade Guard Assembly

.....	JTAS10-BG	Blade Guard Assembly (# 1-10/13/23-26)	1
.....	JTAS12-BG	Blade Guard Assembly (# 1-10/13/23-26)	1
1	JTAS10-G1	Pin	1
2	JTAS10-G2	Guard	1
.....	JTAS12-G2	Guard	1
3	TS-0207091	Hex Socket Cap Screw	1/4x1-1/2	1
4	TS-0680021	Flat Washer	1/4	1
5	JTAS10-G5	Spacer	2
6	TS-0561011	Hex Nut	1/4	1
7	JTAS10-G7	Lock Grommet	3
8	JTAS10-G8	Warning Label	1
9	JTAS10-G9	Support Arm	1
.....	JTAS12-G9	Support Arm	1
10	JTAS10-G10	Pin	1
11	TS-0208061	Hex Cap Bolt	5/16x1	2
12	JTAS10-G12	Plate	1
13	JTAS10-G13	Splitter	1
.....	JTAS12-G13	Splitter	1
14	TS-0051071	Hex Cap Bolt	5/16x1-1/2	2
15	TS-0680031	Flat Washer	5/16	6
16	JTAS10-G15	Upper Blade Guard Bracket	1
17	JTAS10-G16	Lower Blade Guard Bracket	1
18	TS-0720081	Lock Washer	5/16	5
19	TS-0561021	Hex Nut	5/16	2
20	TS-0270031	Set Screw	5/16x3/8	2
21	JTAS10-G21	Shaft (serial # 507050 and below)	1
.....	JTAS10-G21A	Shaft (serial # 508051 and above)	1
22	TS-0720141	Lock Washer	5/8	1
23	JTAS10-G23	Pin	1
24	JTAS10-G24	Anti-Kickback Pawl	2
.....	JTAS12-G24	Anti-Kickback Pawl	2
25	JTAS10-G25	Spring	1
26	JTAS10-G26	Spacer	2
27	TS-0680031	Flat Washer	5/16	1
28	TS-0051021	Hex Cap Bolt	5/16x5/8	1
29	JTAS10-G29	Bracket	1
30	TS-0208021	Hex Socket Cap Screw	5/16 x 1/2	2
.....	TS-0561071	Hex Nut -5/8 (serial # 507050 and below - not shown)	1
.....	477446	12mm Combination Wrench (not shown)	1

Motor and Trunnion Assembly

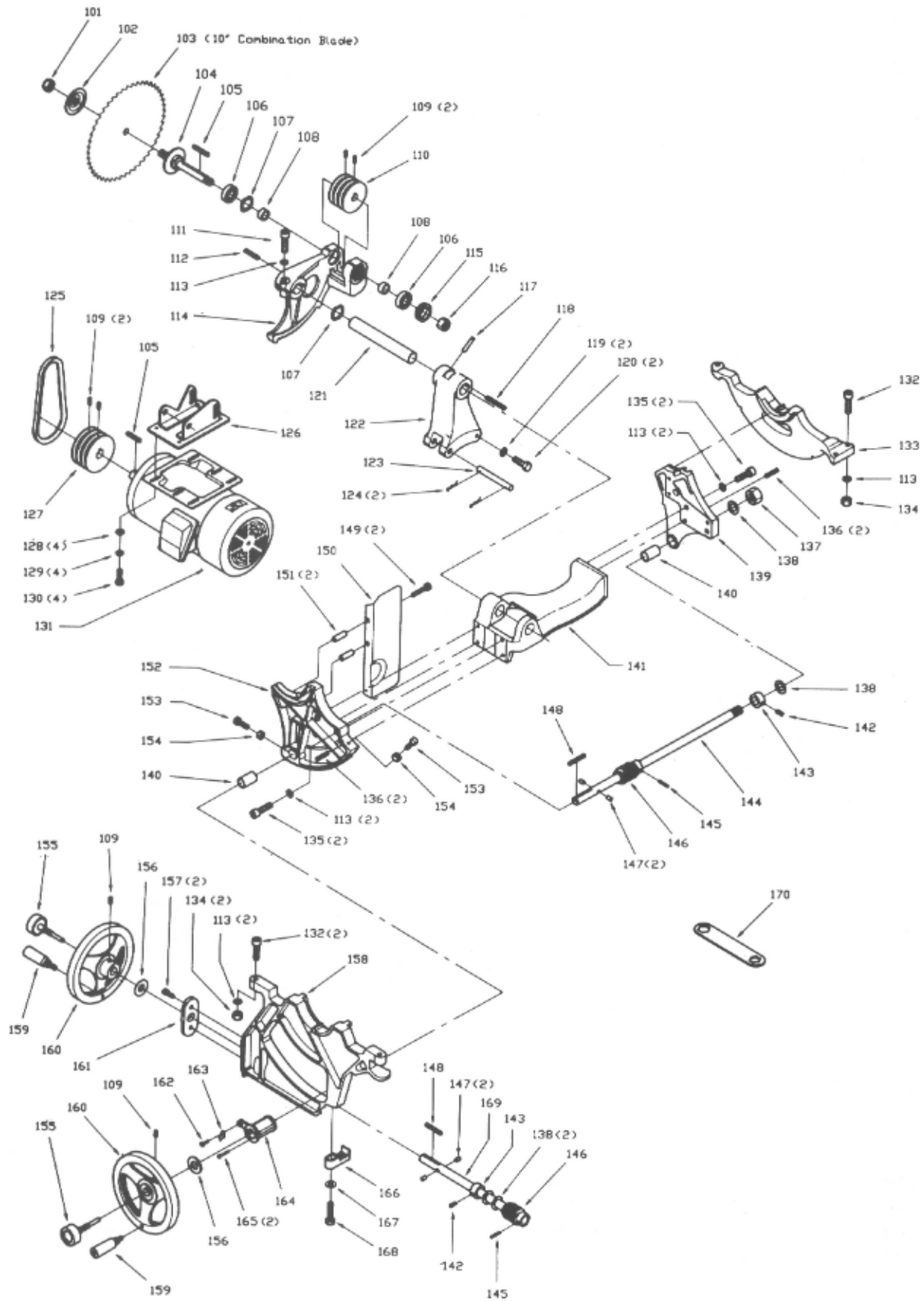

Motor and Trunnion Assembly

101	JTAS10-101	Arbor Nut		1
	JTAS12-101	Arbor Nut		1
102	JTAS10-102	Arbor Flange		1
	JTAS12-102	Arbor Flange		1
104	JTAS10-104	Arbor with Flange		1
	JTAS12-104	Arbor with Flange		1
105	JTAS10-105	Key	M5x1-1/2	1
	JTAS12-105	Key		1
106	BB-6203ZZ	Ball Bearing (JTAS-10 only)		2
	BB-6005ZZ	Ball Bearing (JTAS-12 only)		2
107	JTAS10-107	Bearing Load Spring		2
108	JTAS10-108	Bearing Load Spacer		2
	JTAS12-108	Bearing Load Spacer		2
109	TS-0267041	Set Screw	1/4x3/8	6
110	JTAS10-110	Arbor Pulley		1
	JTAS12-110	Arbor Pulley		1
111	TS-0209031	Hex Socket Cap Screw		1
112	JTAS10-112	Key	1/4x50	1
113	TS-0720091	Lock Washer	3/8	10
114	JTAS10-114	Arbor Bracket		1
	JTAS12-114	Arbor Bracket		1
115	JTAS10-115	Spanner Nut		1
	JTAS12-115	Spanner Nut		1
116	JTAS10-116	Arbor Nut (JTAS-10 only)	5/8	1
	TS-0561081	Hex Nut (JTAS-12 only)	3/4	1
117	JTAS10-117	Spring Pin	M6x50	1
118	JTAS10-118	Key	1/4x75	1
119	TS-0680051	Flat Washer	7/16	2
120	TS-0091031	Hex Cap Bolt	7/16x1	2
121	JTAS10-121	Shaft		1
122	JTAS10-122	Motor Bracket		1
123	JTAS10-123	Pin		1
124	JTAS10-124	Spring Clip		2
125	VB-A23	V-Belt		3
126	JTAS10-126	Motor Plate		1
127	JTAS10-127	Motor Pulley		1
128	TS-0680031	Flat Washer	5/16	4
129	TS-0720081	Lock Washer	5/16	4
130	TS-0051031	Hex Cap Bolt	5/16x3/4	4
131	JTAS10-131	Motor (3HP, 1Ph, 230V only)		1
	JTAS10-131A	Motor (5HP, 3PH, 230/460V)		1
	JTAS12-131	Motor (5HP, 1Ph, 230V only)		1
132	TS-0209071	Hex Socket Cap Screw	3/8x1-1/2	5
133	JTAS10-133	Rear Trunnion Bracket		1
134	TS-0561031	Hex Nut	3/8	5
135	TS-0209051	Hex Socket Cap Screw	3/8x1	4
136	JTAS10-136	Spring Pin	M8x25	4
137	TS-0561081	Hex Nut	3/4	1
138	JTAS10-138	Fiber Washer		4
139	JTAS10-139	Rear Trunnion		1
140	JTAS10-140	Bushing		2
141	JTAS10-141	Yoke		1

.....	JTAS12-141	Yoke	1
142	TS-0270011	Set Screw	5/16x1/4	4
143	JTAS10-143	Collar	2
144	JTAS10-144	Shaft	1
.....	JTAS12-144	Shaft	1
145	JTAS10-145	Spring Pin	M5x30	2
146	JTAS10-146	Worm Gear	2
147	JTAS10-147	Lock Pin	4
148	JTAS10-148	Key	M5x35	2
149	TS-0051071	Hex Cap Bolt (JTAS-10 only)	5/16x1-1/2	2
.....	JTAS12-149	Hex Cap Bolt (JTAS-12 only)	2
150	JTAS10-150	Dust Deflector	1
.....	JTAS12-150	Dust Deflector	1
151	JTAS10-151	Spacer (JTAS-10 only)	2
152	JTAS10-152	Front Trunnion	1
.....	JTAS10-TA	Trunnion Assy. (#113, 135-141)	1
153	TS-0051021	Hex Cap Bolt	5/16x5/8	2
154	TS-0561021	Hex Nut	5/16	2
155	JTAS10-155	Lock Knob 1 (12")/2 (10")
155-1	JTAS12-155	Lock Knob (JTAS-12 only)	1
156	JTAS10-156	Fiber Washer	2
157	TS-0208061	Hex Socket Cap Screw (JTAS-10 only)	5/16x1	2
.....	TS-0208101	Hex Socket Cap Screw (JTAS-12 only)	5/16 x 2	2
158	JTAS10-158	Front Trunnion Bracket	1
.....	JTAS12-158	Front Trunnion Bracket	1
159	JTAS10-159	Hand Wheel Handle	2
160	JTAS10-160	Handle	2
161	JTAS10-161	Shield Plate	1
161-1	JTAS12-161	Adapter (JTAS-12 only)	1
162	JTAS10-162	Round Head Screw	1/4x3/8	1
163	JTAS10-163	Pointer	3/8	1
164	JTAS10-164	Pointer Bracket	1
165	JTAS10-165	Round Head Screw	3/16x2	2
166	JTAS10-166	Guide Block	1
167	TS-0680041	Flat Washer	3/8	1
168	TS-0060071	Hex Cap Bolt	3/8x1-1/2	1
169	JTAS10-169	Tilt Shaft	1
.....	JTAS12-169	Tilt Shaft	1
170	JTAS10-170	Wrench	1
.....	JTAS12-170	Wrench	1

Electrical Schematic - Single Phase- 230V

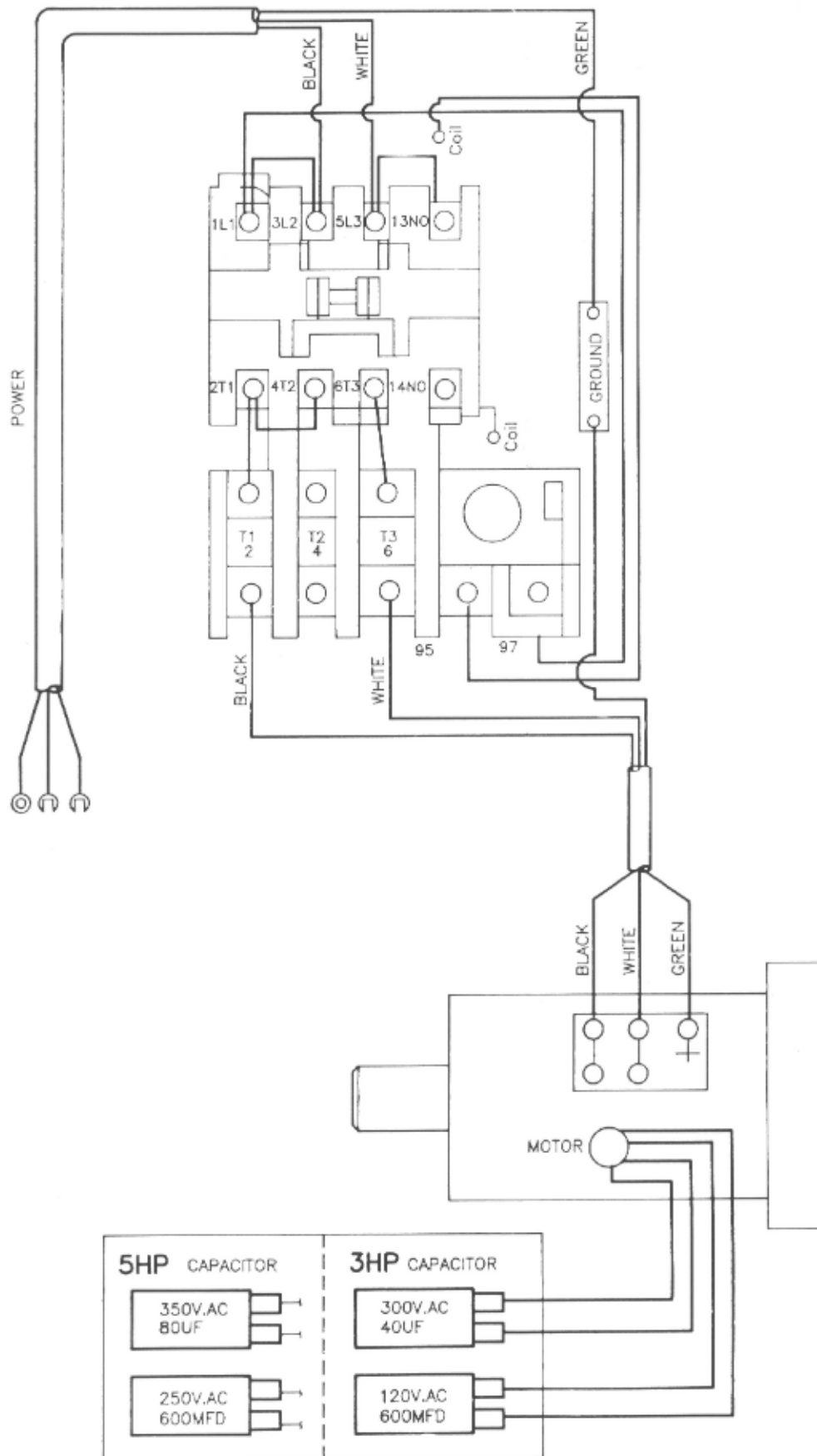

Electrical Schematic - Three Phase

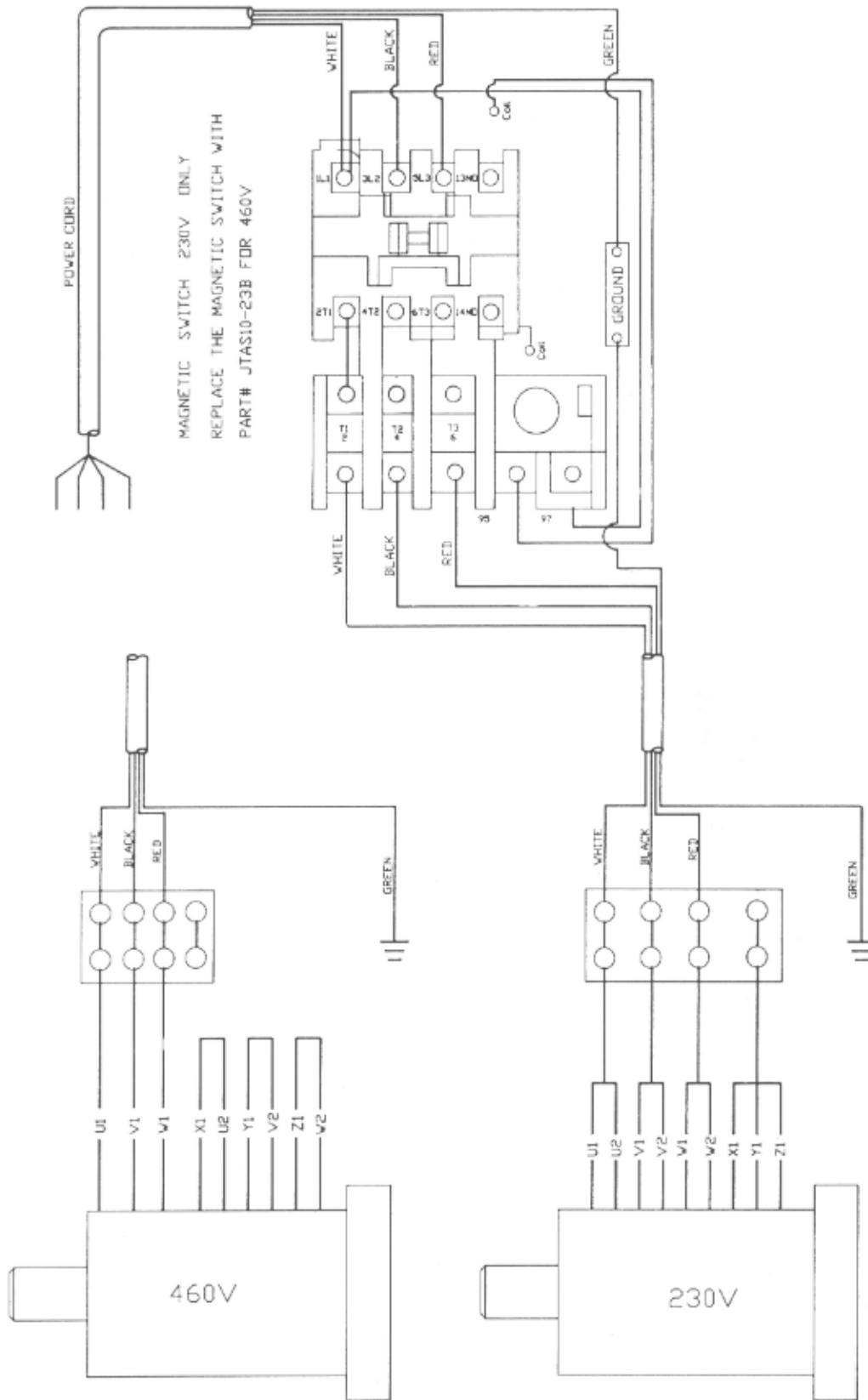

J E T[®]

WMH Tool Group
2420 Vantage Drive
Elgin, Illinois 60123
Phone: 800-274-6848
www.wmhtoolgroup.com



Owner's Manual XACTA[®] Fence II Commercial 30/50



WMH TOOL GROUP
2420 Vantage Drive
Elgin, Illinois 60124
Ph.: 800-274-6848
www.wmhtoolgroup.com

Part No. M-708950Z
Revision J 01/07
Copyright © WMH Tool Group

Warranty and Service

WMH Tool Group, Inc., warrants every product it sells. If one of our tools needs service or repair, one of our Authorized Service Centers located throughout the United States can give you quick service. In most cases, any of these WMH Tool Group Authorized Service Centers can authorize warranty repair, assist you in obtaining parts, or perform routine maintenance and major repair on your JET® tools. For the name of an Authorized Service Center in your area call 1-800-274-6848.

MORE INFORMATION

WMH Tool Group is consistently adding new products to the line. For complete, up-to-date product information, check with your local WMH Tool Group distributor, or visit jettools.com.

WARRANTY

JET products carry a limited warranty which varies in duration based upon the product (MW stands for Metalworking, WW stands for Woodworking).

90 DAY WARRANTY	1 YEAR WARRANTY	2 YEAR WARRANTY	5 YEAR WARRANTY	LIFE LIFETIME WARRANTY
Lathe Accessories Machine Accessories Mobile Bases Safety Equipment Specialty Items	Contractor Air Tools Hydraulic & Shop Tools Industrial Air Tools Light Industrial Air Tools Overhead Lifting Warehouse & Dock Equipment Winches	Metalworking Mechanical Components: Cold Saws MW Finishing Equipment Metalforming MW Lathes Mill/Drills MW Vises Milling Machines Surface Grinders MW Bandsaws Tapping MW Drill Presses	Air Filtration Sanders Buffers Shapers Dust Collectors Tablesaws Dust Filters WW Bandsaws Dust Fittings WW Drill Presses Jointers WW Lathes Planers	Fastening Tools Lubrication Mechanics Hand Tools Striking Tools Vise Accessories Vises (non-MW) Clamps Workholding
<i>Metalworking Electrical Components on above products carry 1 Year Warranty</i>			<i>Warranty reverts to 1 Year if above products are used for commercial, industrial or educational purposes</i>	

WHAT IS COVERED?

This warranty covers any defects in workmanship or materials subject to the exceptions stated below. Cutting tools, abrasives and other consumables are excluded from warranty coverage.

WHO IS COVERED?

This warranty covers only the initial purchaser of the product.

WHAT IS THE PERIOD OF COVERAGE?

The general JET warranty lasts for the time period specified in the product literature of each product.

WHAT IS NOT COVERED?

Five Year and Lifetime Warranties do not cover products used for commercial, industrial or educational purposes. Products with Five Year or Lifetime Warranties that are used for commercial, industrial or education purposes revert to a One Year Warranty. This warranty does not cover defects due directly or indirectly to misuse, abuse, negligence or accidents, normal wear-and-tear, improper repair or alterations, or lack of maintenance.

HOW TO GET SERVICE

The product or part must be returned for examination, postage prepaid, to a location designated by us. For the name of the location nearest you, please call 1-800-274-6848.

You must provide proof of initial purchase date and an explanation of the complaint must accompany the merchandise. If our inspection discloses a defect, we will repair or replace the product, or refund the purchase price, at our option. We will return the repaired product or replacement at our expense unless it is determined by us that there is no defect, or that the defect resulted from causes not within the scope of our warranty in which case we will, at your direction, dispose of or return the product. In the event you choose to have the product returned, you will be responsible for the shipping and handling costs of the return.

HOW STATE LAW APPLIES

This warranty gives you specific legal rights; you may also have other rights which vary from state to state.

LIMITATIONS ON THIS WARRANTY

WMH TOOL GROUP LIMITS ALL IMPLIED WARRANTIES TO THE PERIOD OF THE LIMITED WARRANTY FOR EACH PRODUCT. EXCEPT AS STATED HEREIN, ANY IMPLIED WARRANTIES OR MERCHANTABILITY AND FITNESS ARE EXCLUDED. SOME STATES DO NOT ALLOW LIMITATIONS ON HOW LONG THE IMPLIED WARRANTY LASTS, SO THE ABOVE LIMITATION MAY NOT APPLY TO YOU.

WMH TOOL GROUP SHALL IN NO EVENT BE LIABLE FOR DEATH, INJURIES TO PERSONS OR PROPERTY, OR FOR INCIDENTAL, CONTINGENT, SPECIAL, OR CONSEQUENTIAL DAMAGES ARISING FROM THE USE OF OUR PRODUCTS. SOME STATES DO NOT ALLOW THE EXCLUSION OR LIMITATION OF INCIDENTAL OR CONSEQUENTIAL DAMAGES, SO THE ABOVE LIMITATION OR EXCLUSION MAY NOT APPLY TO YOU.

WMH Tool Group sells through distributors only. The specifications in WMH catalogs are given as general information and are not binding. Members of WMH Tool Group reserve the right to effect at any time, without prior notice, those alterations to parts, fittings, and accessory equipment which they may deem necessary for any reason whatsoever. JET® branded products are not sold in Canada by WMH Tool Group.

Table of Contents

Warranty and Service.....	2
Table of Contents	3
Warnings	4
Ordering Replacement Parts.....	5
Unpacking	6
Contents of the Shipping Containers.....	6
Tools Required for Assembly & Adjustment.....	6
Installation	7
Tools required.....	7
Front Rail Installation.....	7
Switch Installation.....	7
Back Rail Installation	8
Wooden Extension Table	9
Tools required.....	9
Installation	9
Guide Tube	10
XACTA Fence	11
Leveling Fence to the Saw Table	11
Adjusting Fence Parallel to the Miter Slot.....	12
Clamping Pressure	12
90° to the Table.....	12
Cursor Adjustment	12
Parts for the XACTA Fence II Commercial 30/50	13
Parts for the XACTA Fence II Rail Assembly.....	14
Parts for the XACTA Fence II Leg Assembly.....	15
Appendix – Extension Table Dimensions	15

The specifications in this manual are given as general information and are not binding. WMH Tool Group reserves the right to effect, at any time and without prior notice, changes or alterations to parts, fittings, and accessory equipment deemed necessary for any reason whatsoever.



Warnings

1. Read and understand the entire owners manual before attempting assembly or operation.
2. Read and understand the warnings posted on the machine and in this manual. Failure to comply with all of these warnings may cause serious injury.
3. Replace the warning labels if they become obscured or removed.
4. The Table Saw on which the XACTA Fence II is used is designed and intended for use by properly trained and experienced personnel only. If you are not familiar with the proper and safe operation of a Table Saw, do not use until proper training and knowledge have been obtained.
5. Do not use this Table Saw on which the XACTA Fence II is used for other than its intended use. If used for other purposes, WMH Tool Group disclaims any real or implied warranty and holds itself harmless from any injury that may result from that use.
6. Always wear approved safety glasses/face shields while using this Table Saw. Everyday eyeglasses only have impact resistant lenses; they are not safety glasses.
7. Before operating the Table Saw, remove tie, rings, watches and other jewelry, and roll sleeves up past the elbows. Remove all loose clothing and confine long hair. Non-slip footwear or anti-skid floor strips are recommended. Do **not** wear gloves.
8. Wear ear protectors (plugs or muffs) during extended periods of operation.
9. Some dust created by power sanding, sawing, grinding, drilling and other construction activities contain chemicals known to cause cancer, birth defects or other reproductive harm. Some examples of these chemicals are:
 - Lead from lead based paint.
 - Crystalline silica from bricks, cement and other masonry products.
 - Arsenic and chromium from chemically treated lumber.
10. Your risk of exposure varies, depending on how often you do this type of work. To reduce your exposure to these chemicals, work in a well-ventilated area and work with approved safety equipment, such as face or dust masks that are specifically designed to filter out microscopic particles.
11. Do not operate this machine while tired or under the influence of drugs, alcohol or any medication.
12. Make certain the switch is in the **OFF** position before connecting the machine to the power supply.
13. Make certain the machine is properly grounded.
14. Make all machine adjustments or maintenance with the machine unplugged from the power source.
15. Remove adjusting keys and wrenches. Form a habit of checking to see that keys and adjusting wrenches are removed from the machine before turning it on.
16. Keep safety guards in place at all times when the machine is in use. If removed for maintenance purposes, use extreme caution and replace the guards immediately.
17. Make sure the Table Saw is firmly secured to the floor or bench before use.
18. Check damaged parts. Before further use of the machine, a guard or other part that is damaged should be carefully checked to determine that it will operate properly and perform its intended function. Check for alignment of moving parts, binding of moving parts, breakage of parts, mounting and any other conditions that may affect its operation. A guard or other part that is damaged should be properly repaired or replaced.
19. Provide for adequate space surrounding work area and non-glare, overhead lighting.
20. Keep the floor around the machine clean and free of scrap material, oil and grease.
21. Keep visitors a safe distance from the work area. **Keep children away.**



Warnings

22. Make your workshop child proof with padlocks, master switches or by removing starter keys.
23. Give your work undivided attention. Looking around, carrying on a conversation and “horse-play” are careless acts that can result in serious injury.
24. Maintain a balanced stance at all times so that you do not fall into the blade or other moving parts. Do not overreach or use excessive force to perform any machine operation.
25. Use the right tool at the correct speed and feed rate. Do not force a tool or attachment to do a job for which it was not designed. The right tool will do the job better and safer.
26. Use recommended accessories; improper accessories may be hazardous.
27. Maintain tools with care. Keep saw blades sharp and clean for the best and safest performance. Follow instructions for lubricating and changing accessories.
28. Turn off the machine before cleaning. Use a brush or compressed air to remove chips or debris — do not use your hands.
29. Do not stand on the machine. Serious injury could occur if the machine tips over.
30. Never leave the machine running unattended. Turn the power off and do not leave the machine until it comes to a complete stop.
31. Remove loose items and unnecessary work pieces from the area before starting the machine.

Familiarize yourself with the following safety notices used in this manual:



This means that if precautions are not heeded, it may result in minor injury and/or possible machine damage.



This means that if precautions are not heeded, it may result in serious injury or possibly even death.

Ordering Replacement Parts

To order parts or reach our service department, call 1-800-274-6848 between 7:30 a.m. and 5:30 p.m. (CST), Monday through Friday. Having the Model Number and Serial Number of your machine available when you call will allow us to serve you quickly and accurately.

Unpacking

Open shipping cartons and check that all parts are intact. Report any damage immediately to your distributor. Read the instruction manual thoroughly for assembly, alignment, and maintenance instructions.

Contents of the Shipping Containers

- 1 XACTA Fence II
- 1 Front Rail
- 1 Rear Rail
- 1 Guide Rail
- 3 Black Plastic End Caps
- 1 Hardware Package
- 1 Owner's Manual
- 1 Warranty Registration Card

The contents of the hardware bag are drawn full scale in Figure 1.

Note 1: Quantities may vary depending upon whether you purchased the short rail or long rail.

Note 2: If the optional wooden extension table is not used, there will be extra hardware.

Tools Required for Assembly & Adjustment

- 1 #3 Cross Point Screwdriver
- 1 7/16" Wrench
- 1 1/2" Wrench
- 1 Combination Square & Straight Edge
- 1 Electric Drill
- 1 1/4", 3/16" Drill Bits
- 2 4"-6" C-Clamps
- 1 1/4", 3/16" Allen Wrenches

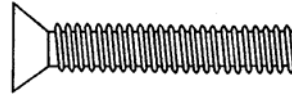

Flat Head Screw
1/4-20 x 1-1/2



Hex Cap Screw
1/4-20 x 1-1/2



Hex Cap Screw
1/4-20 x 3/4

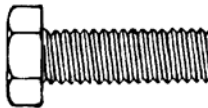

Hex Cap Screw
5/16-18 x 3/4

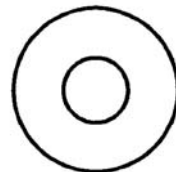

5/16 Flat Washer

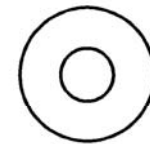

1/4 Flat Washer



1/4 Lock Washer



1/4 Hex Nut

Installation

Tools required

7/16" and 1/2" wrenches
Cross point screwdriver
3/16" hex wrench
Adjustable square
Hammer (or rubber mallet)
Straight edge

The following instructions are for installing the XACTA Fence II and Rail System on JET Models JTAS-10, JTAS-12 and XACTA® Saw Deluxe series table saws. The rails should bolt up to the JET saw without any drilling.

Front Rail Installation

Referring to Figures 1 and 2:

1. Identify the *front rail* (E), which is 2-1/2" x 2-1/2" with notches on one side and countersunk mounting holes on the other side.
2. Lightly secure the *front rail* (E) to the table (G) and *extension wings* (F) with four each 1/4 x 1-1/2" *flat head screws* (A), 1/4" *flat washers* (B), 1/4" *lock washers* (C) and 1/4" *hex nuts* (D). Tighten just enough to hold the rail next to the table but keep loose enough to allow height adjustment.

The *front rail* must be 9/16" down from the table top in order to clear the miter gauge slot. This measurement is critical.

3. Place an adjustable square on the table as shown in Figure 3.
4. Check the height of the front rail at several locations along the surface of the saw table. The front rail **must** be parallel with the table top.

When the front rail has been correctly positioned:

5. Use a #3 cross point screwdriver and 7/16" wrench to tighten all mounting screws securely. However, do not tighten hardware for the *left extension table* (shown in F, Fig. 1).

The hardware that secures the left extension table should be left loose to accommodate the switch installation (below).

Switch Installation

At this time refer to your JTAS-10, JTAS-12 or XACTA® Saw manual and attach the switch as described in the *Switch Installation* section. The switch *should* be attached before the guide tube installation covered later in this manual.

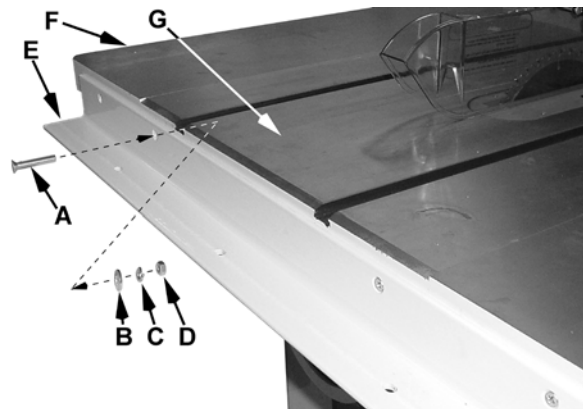
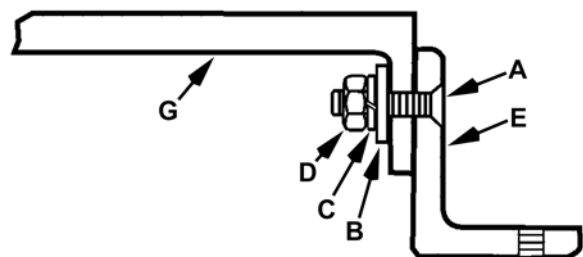

Figure 1



- A - 1/4'-20 x 1-1/2" Flat Head Screw
- B - 1/4" Flat Washer
- C - 1/4" Lock Washer
- D - 1/4" Hex Nut

Figure 2

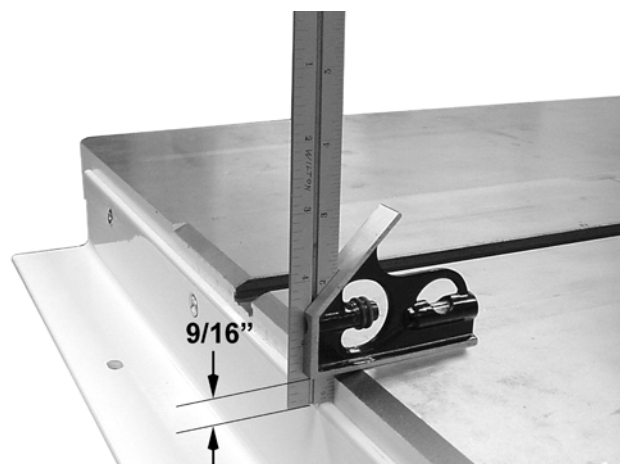

Figure 3

Back Rail Installation

1. Locate the *back rail* which is 2" x 2" with holes running along one side only. The height of the *back rail* when attached to the saw is not critical.
2. Align the holes in the *back rail* to the holes in the table top, as shown in Figure 4.

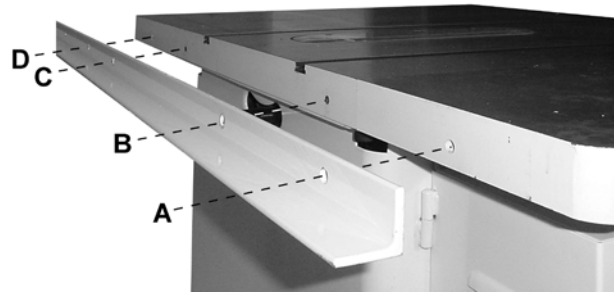

Figure 4

3. Secure the back rail to the pre-tapped holes in the saw table (B, C, Fig. 4) with two 5/16 x 3/4 hex cap screws and two 5/16 flat washers, as shown in Figure 5. Tighten screws securely with a 1/2" wrench.

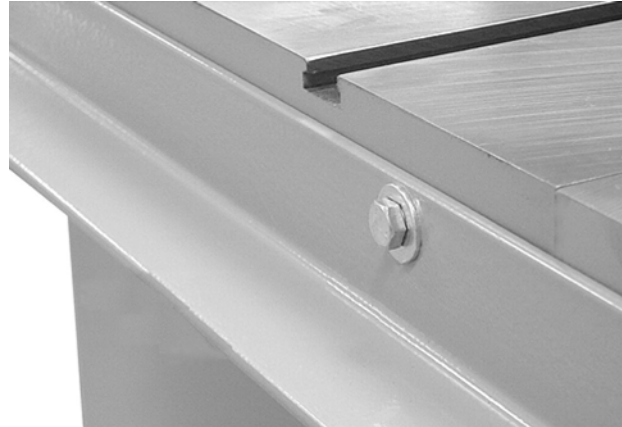

Figure 5

4. Secure the back rail at A and D (in Figure 4) to each *extension wing* with a 1/4 x 1-1/2 hex cap screw, two 1/4" flat washers, a 1/4" lock washer, and a 1/4" hex nut as shown in Figure 6.
5. Tighten nuts.

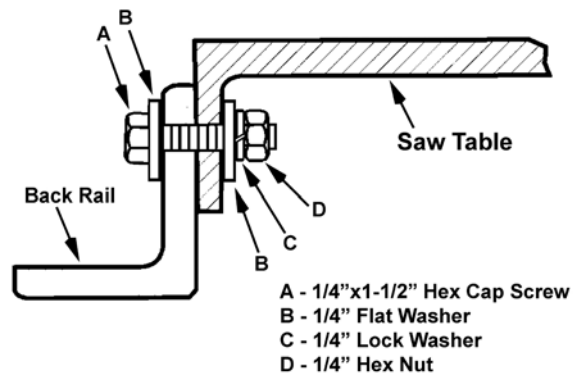

Figure 6

Important: If you are installing an optional wood extension table on your saw, it should be installed first **before** mounting the guide tube. This will prevent having to mount and align the guide tube twice.

If you are not mounting an optional wood table, proceed to *Guide Tube* section.

Wooden Extension Table

The *wooden extension table* is an optional accessory.

Tools required

- Electric drill
- Cross point screwdriver
- 7/16" and 1/2" wrenches
- Four clamps
- Straight edge
- Hammer (or rubber mallet)

Installation

The optional wood extension table (including the optional router table) sits flush against the saw table and along the inside of the rails. The JET logo (or warning label on the router table) should face outward. The extension table is not bolted to the saw table, it is bolted only to the rails.

The extension table and saw table must be aligned properly so the XACTA Fence II will slide smoothly from one to the other.

1. Place the extension table between the rails and up against the saw table, leaving the extension table raised just slightly above the saw table. Clamp the extension table to the front and back rails as shown in Figure 7. Clamping pressure should be enough to secure the table yet allow minor adjustments.
2. Use a hammer and block of wood (or a rubber mallet) to tap the extension table up flush against the cast iron saw table (Figure 7). Then tap down the extension table at various points along its edge where it meets the saw table, until it is level with the saw table (Figure 8). As one part of the edge becomes level with the table, tighten the clamp on that side. Then move to the other side and repeat, until the full length of the edge is level with the saw table. Lay a straight edge across both extension table and saw table to ensure proper leveling.

When extension table is properly aligned, holes need to be drilled into the wood table using the holes in the rails as your guide (Figure 9). *You may wish to drill 3/32" pilot holes first.*

3. Drill 1/4" holes into the front edge of the table using the holes in the front rail as a guide. Drill 1/4" holes into the back edge of the table using the holes in the back rail as a guide.
4. Install three 1/4 x 1-1/2 flat head screws, three 1/4 flat washers, and three 1/4 hex nuts into the holes in the front edge of extension table

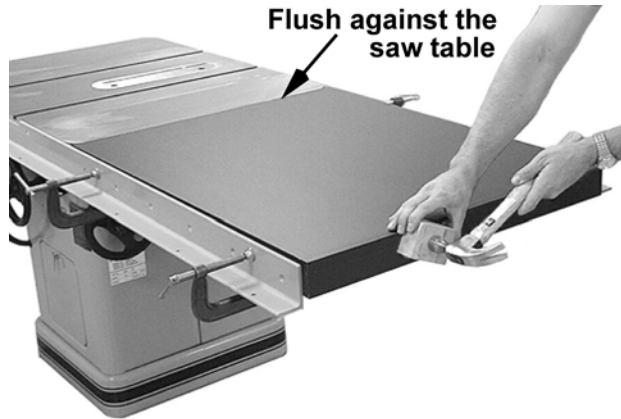

Figure 7

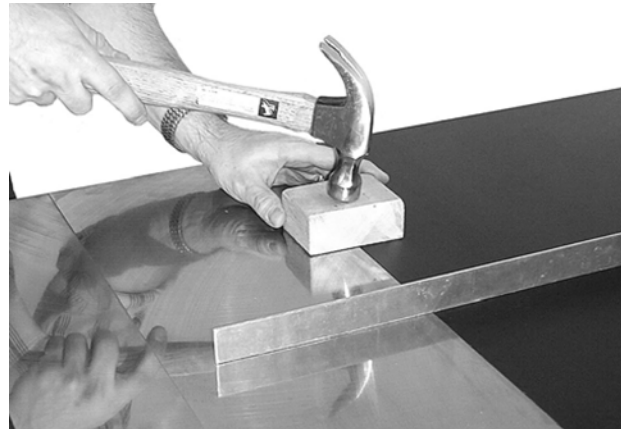

Figure 8

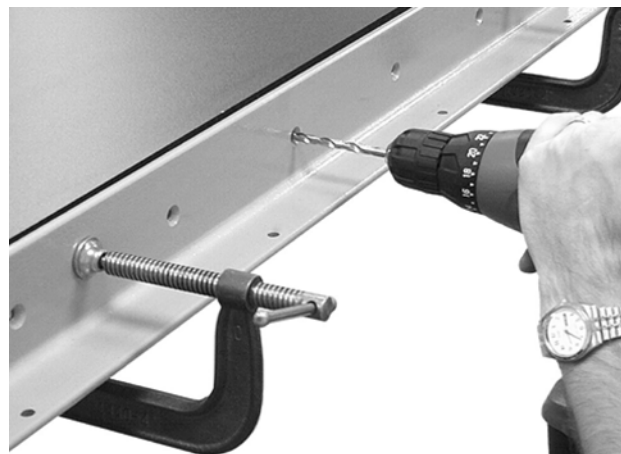

Figure 9

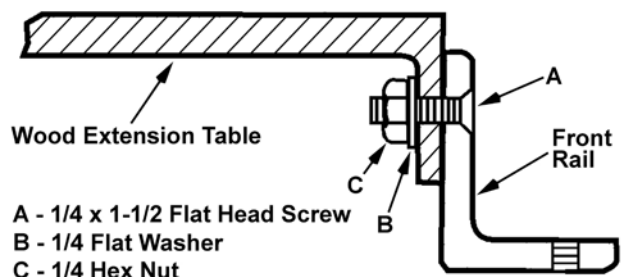

Figure 10

as shown in Figure 10. Finger tighten only.

5. Install three 1/4-20 x 1-1/2 hex cap screws, three 1/4 flat washers, and three 1/4 nuts into the holes in the rear edge of extension table as shown in Figure 11. Finger-tighten only.
6. Re-check the table for alignment, make further adjustments if necessary, then tighten all screws and nuts.

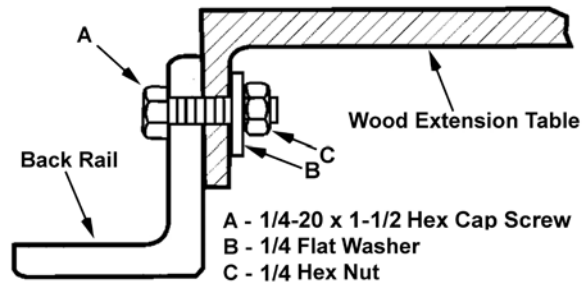

Figure 11

7. Mount the two legs to the inside corners of the extension table as shown in Figure 12. Secure with the eight screws provided.

Note: If you are using a mobile base under your saw, you may need to shift the placement of the legs so they rest properly upon the shelves of the base.

8. Adjust the footpads on the legs counterclockwise until they reach the floor, then tighten the nut.



Figure 12

Guide Tube

Important: Before proceeding with the *guide tube* installation, the *table saw switch* should already be installed. If not, refer to the *Switch Installation* section in your JTAS-10, JTAS-12 or XACTA® Saw manual.

Referring to Figure 13:

The *guide tube* (A) is placed on top of the *front rail* (B) and is mounted with the scale facing toward the operator.

1. Align the holes in the bottom of the *guide tube* with the holes in the *front rail*. When properly positioned the *guide tube* should extend beyond the *front rail* about 6" in both directions.
2. Fasten the *guide tube* (A) to the rail (B) from beneath, with seven 1/4-20 x 3/4 hex head screws (B), seven 1/4" lock washers (F) and seven 1/4" flat washers (G). Finger tighten only.
3. Tighten all screws with a 7/16" wrench.

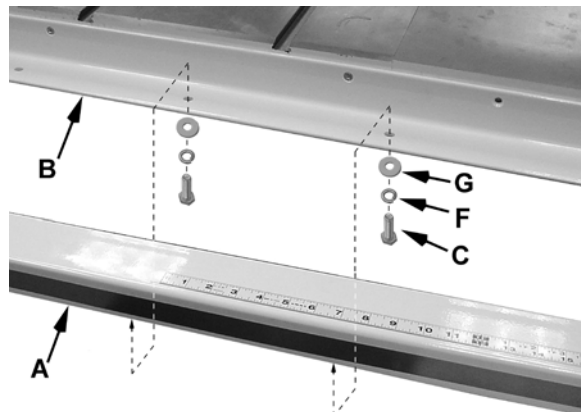

Figure 13

XACTA Fence

Screw the lock lever knob into the threaded handle on the XACTA Fence II as shown in Figure 14.

The lock lever has three functional positions as shown in Figure 15:

- The upright position permits mounting and removal of fence from the saw.
- The unlock position permits easy fence positioning.
- The lower position locks the fence to the front rail. The cam handle should be pushed down firmly against the pin.

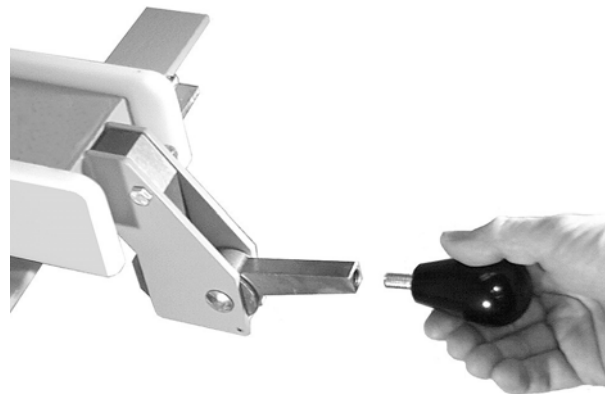

Figure 14

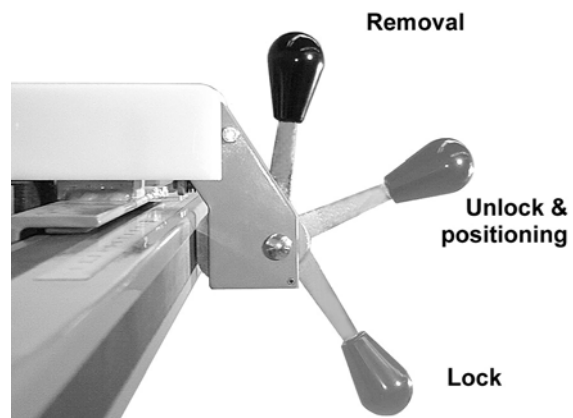

Figure 15

Leveling Fence to the Saw Table

1. Place the fence on the table and lock it.
2. View the fence from the left side of the saw (Figure 16). Look for the space *between the table and the fence bottom* to be equal along the entire length of the fence (A, B, Fig. 16).

If adjustment is necessary:

3. Unlock the fence.
4. Using a 10mm wrench, loosen the *lock nut* that secures the foot adjustment (C, Fig. 16)
5. Rotate the *foot*, retracting it such that it does not come in contact with the *back rail* (Fig. 16).
6. Raise or lower two nylon adjustment screws (D, Fig. 17) *the same number of turns* until the space between the bottom of the fence and the table is the same. Care must be taken to raise or lower the fence on each side equally or the fence may not be 90° to the table after the height adjustment is performed.

When the space at points A and B (Fig. 16) are the same:

7. Extend the *foot* (C, Fig. 16) by rotating it until it just comes in contact with the *back rail*.
8. Tighten the *lock nut* to secure the *foot*, preventing it from further rotation.

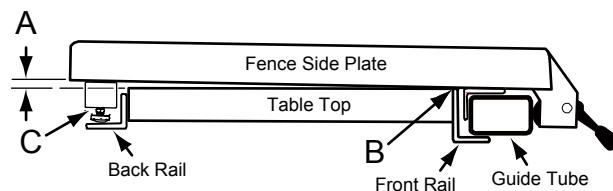

Figure 16

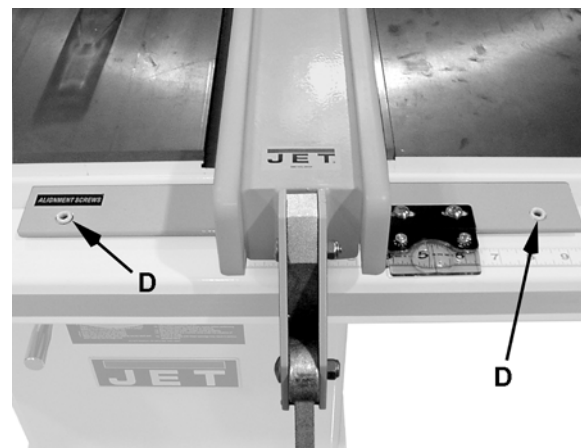

Figure 17

Adjusting Fence Parallel to the Miter Slot

1. Place the fence next to the outside edge of the right miter slot and lock it.
2. The fence should be even with the miter slot from front to back.
3. If the fence is not even along the length of the miter slot, unlock the fence, remove it and turn upside down.
4. Adjust one of the two setscrews (A, Fig. 18) until the fence is even with the miter slot edge along its entire length when locked.

Note: You may need to re-adjust the clamping pressure after aligning the fence.

Clamping Pressure

The XACTA Fence II has been adjusted at the factory to lock securely when the lock handle is pushed down. If adjustment is needed:

1. Unlock the fence.
2. Remove the fence from the guide rail.
3. Turn the fence over.
4. Adjust each of the two setscrews (A, Fig. 18) exactly the same number of rotations until the fence is held securely when the lock handle is pushed down.

90° to the Table

1. Place the fence on the saw table and lock it.
2. Place a square (A, Fig. 19) on the table next to the fence. The fence should be 90° to the table.
3. If adjustment is necessary, unlock the fence, and turn one of the two nylon adjustment screws (B, Fig. 19) until the fence is 90° to the table.
4. Lock the fence and check the adjustment again.

Cursor Adjustment

1. Disconnect the table saw from the power source.
2. Raise the saw blade above the tabletop.
3. Unlock the fence and slide it to approximately four inches from the saw blade.
4. Lock the fence.
5. Measure the distance between the saw blade and the inside of the fence.
6. Adjust the cursor (C, Fig. 19) to read the distance just measured and tighten the cursor assembly to the fence.
7. Take a test cut and confirm the adjustment is correct.



Figure 18

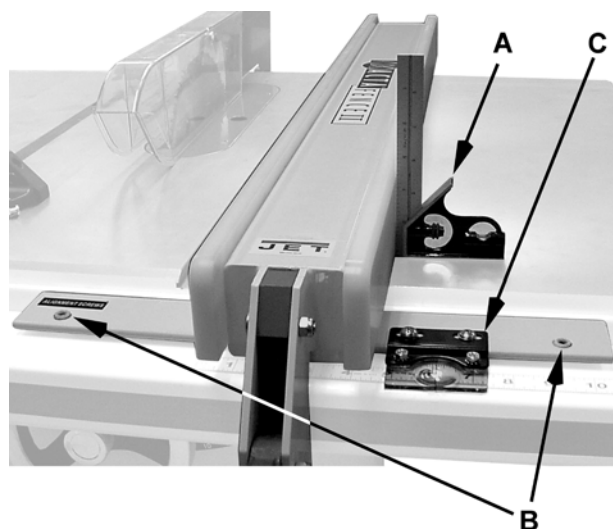

Figure 19

Note: If the cursor does not have enough travel to give the correct measurement loosen the guide rail and adjust as needed. If you still do not get the correct measurement loosen the front rail and adjust as needed. If you have to adjust the front rail you will need to go through the front rail assembly instructions again.

This adjustment must be checked whenever a different blade is installed.

After installing the XACTA Fence II press the black plastic end caps into the openings of the guide rail. There is also an end cap for the fence, but this should already be installed.

Parts for the XACTA Fence II Commercial 30/50

Index No.	Part No.	Description	Size	Qty
1	XF2-101	Left Side Plate		1
2	XF2-102	Fence Body Assembly		1
3	XF2-103	Tube Cover		1
4	XF2-104	Right Side Plate		1
5	TS-0640071	Lock Nut	1/4"-20	10
6	TS-0271031	Set Screw	3/8"-16 x 3/8"	2
7	3575081	Fluoroway Pad		2
8	XF2-108	Pad		1
9	TS-0151011	Carriage Bolt	1/4"-20 x 3/4"	10
10	TS-081D022	Pan Head Machine Screw	10-32 x 3/8"	2
11	TS-0680021	Flat Washer	1/4"	2
12	TS-081D021	Flat Head Machine Screw	10-32 x 3/8"	2
13	800708950 D	Cursor		1
14	800708950 C	Cursor Bracket		1
15	TS-0640071	Lock Nut	1/4"-20	1
16	TS-0640091	Lock Nut	3/8"-16	1
17	XF2-117	Spring Pin	4mm x 28	1
18	6813042	Compression Spring		1
19	TS-0151041	Carriage Bolt	1/4"-20 x 1-1/2"	1
20	TS-0160021	Carriage Bolt	3/8"-16 x 1-1/2"	1
21	3215301	Foot Cam		1
22	3076232	Lock Cam		1
23	6430055	Knob w/stud		1
24	XF-5	Nylon Adjustment Screw		2
25	TS-0680021	Flat Washer	1/4"	2
26	TS-0560081	Hex Nut	10-32	2
27	XF2-127	XCTA Fence Label		1
28	XF2-128	Instruction Label		1
29	XF2-129	JET Label		1
30	XF2-130	Foot Pad Holder		1
31	TS-0207061	Socket Head Cap Screw	1/4"-20 x 1"	2
32	TS-0561011	Hex Nut	1/4"-20	1
33	XF2-133	Foot Pad		1

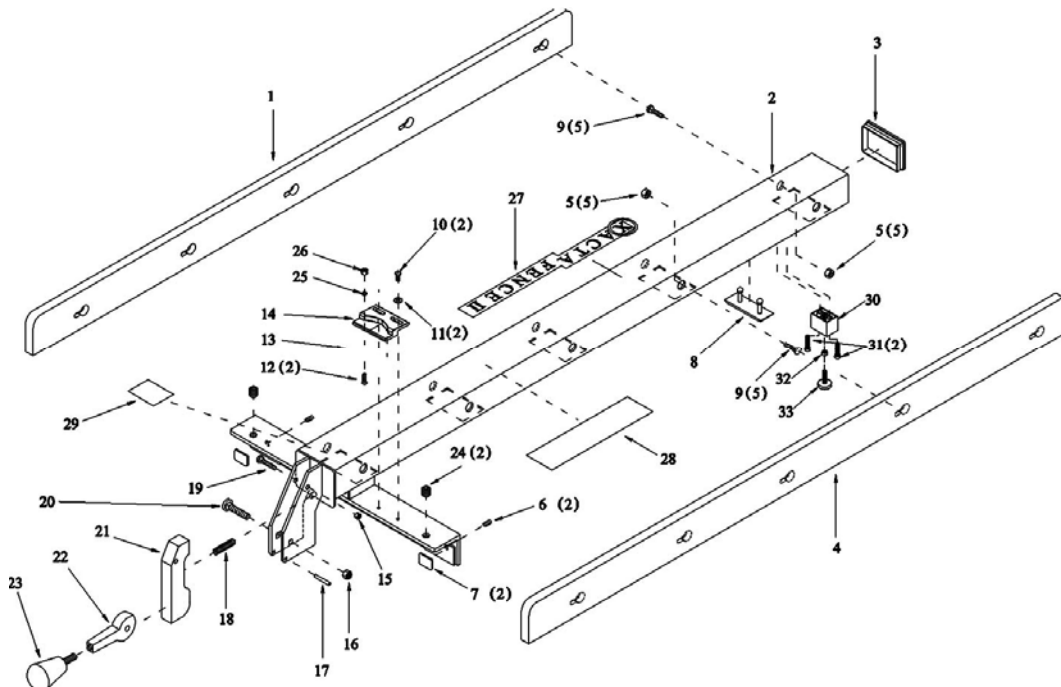

Parts for the XACTA Fence II Rail Assembly

Index No.	Part No.	Description	Size	Qty
1	XF2-201	Front Rail (50")		1
	XF2-201A	Front Rail (30")		1
2	TS-081F081	Flat Head Screw	1/4"-20 x 1-1/2"	7
3	TS-0680021	Flat Washer	1/4"	24
4	TS-0720071	Lock Washer	1/4"	19
5	TS-0561011	Hex Nut	1/4"-20	12
6	TS-0050031	Hex Cap Screw	1/4"-20 x 3/4"	7
7	XF2-207	Scale (50")		1
	XF2-207A	Scale (30")		1
8	XF2-208	Guide Rail (50")		1
	XF2-208A	Guide Rail (30")		1
9	XF2-209	Rear Rail (50")		1
	XF2-209A	Rear Rail (30")		1
10	XF2-210	Guide cover		2
11	TS-0081031	Hex Cap Screw	5/16"-18 x 3/4"	2
12	TS-0050071	Hex Cap Screw	1/4"-20 x 1-1/2"	5
13	TS-0680031	Flat Washer	5/16"	2

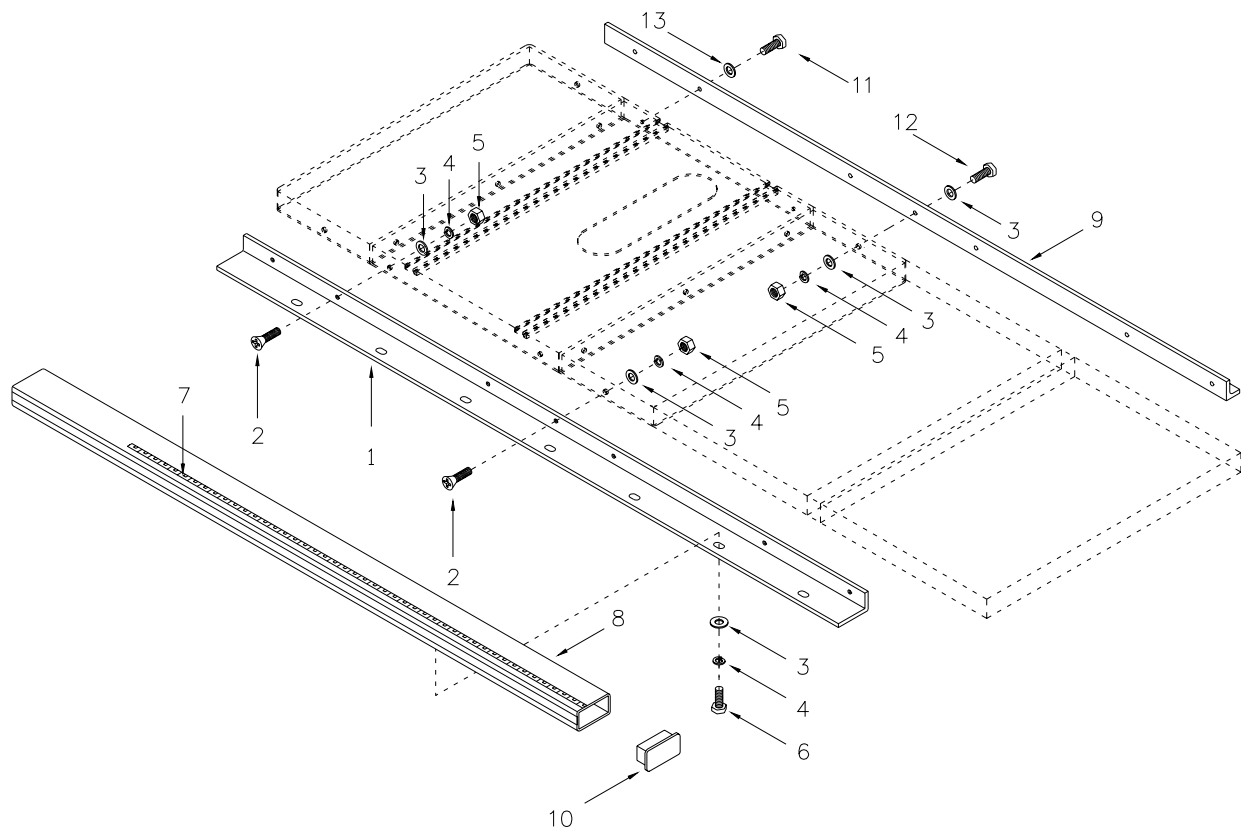

Parts for the XACTA Fence II Leg Assembly

Index No.	Part No.	Description	Size	Qty
1	XF2-301	Leg		2
2	TS-0561031	Hex Nut	3/8"-16	2
3	XF2-303	Adjusting foot		2
4	TS-1533052	Machine Screw	M5×16	8

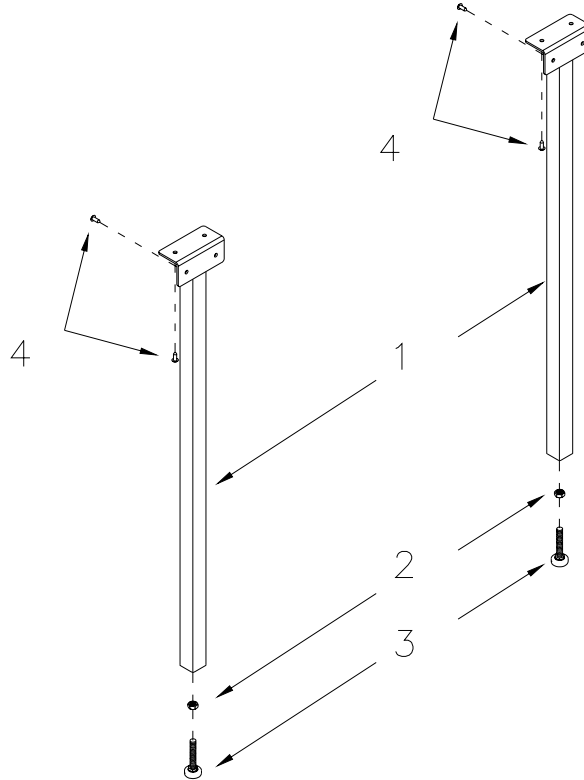

Appendix – Extension Table Dimensions

The dimensions below are provided if you plan to build your own extension table instead of purchasing one that is available through JET.

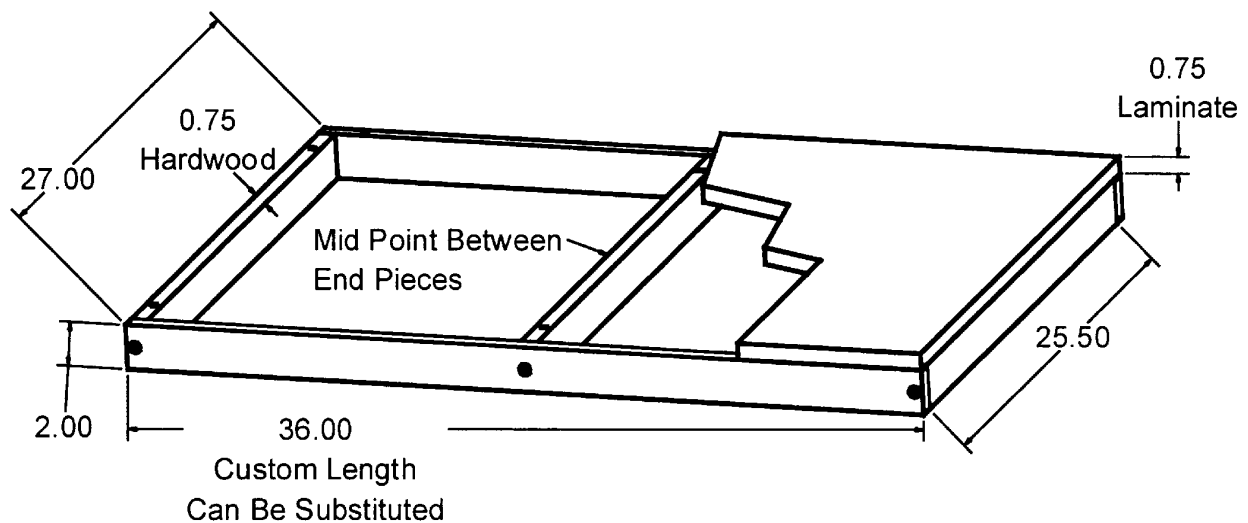



WMH Tool Group
2420 Vantage Drive
Elgin, Illinois 60124
Phone: 800-274-6848
www.wmhtoolgroup.com

Free Manuals Download Website

<http://myh66.com>

<http://usermanuals.us>

<http://www.somanuals.com>

<http://www.4manuals.cc>

<http://www.manual-lib.com>

<http://www.404manual.com>

<http://www.luxmanual.com>

<http://aubethermostatmanual.com>

Golf course search by state

<http://golfingnear.com>

Email search by domain

<http://emailbydomain.com>

Auto manuals search

<http://auto.somanuals.com>

TV manuals search

<http://tv.somanuals.com>