

POWERMATIC®

WMH | TOOL GROUP

Operating Instructions and Parts Manual Tilting Table Hollow Chisel Mortiser

Model: 719T

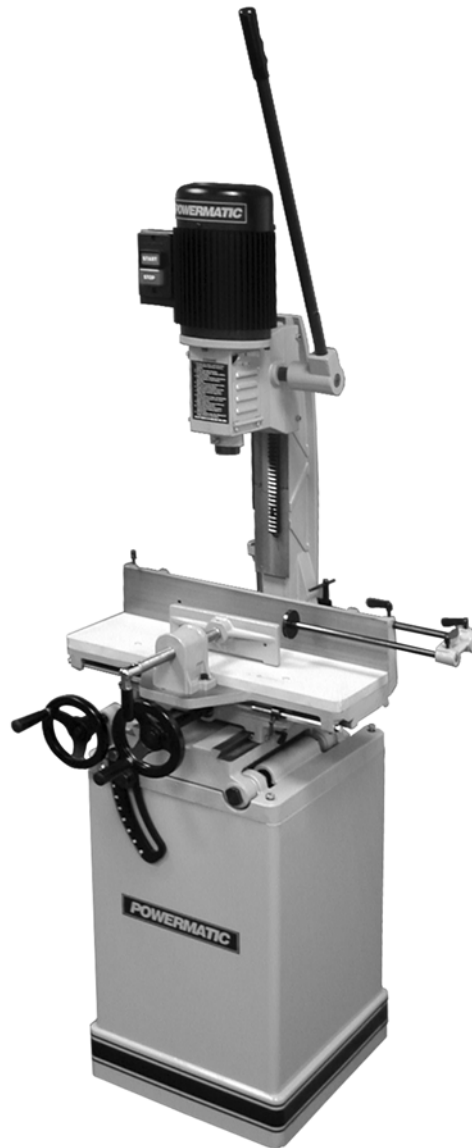

WMH TOOL GROUP
2420 Vantage Drive
Elgin, Illinois 60123
Ph.: 800-274-6848
www.wmhtoolgroup.com

Part No. M-2474002
Revision A 03/04
Copyright © WMH Tool Group

This manual has been prepared for the owner and operators of a POWERMATIC 719T Tilting Table Hollow Chisel Mortiser. Its purpose, aside from machine operation, is to promote safety using accepted operating and maintenance procedures. To obtain maximum life and efficiency from your mortiser and to aid in using it safely, please read this manual thoroughly and follow the instructions carefully.

Warranty and Service

WMH Tool Group warrants every product it sells. If one of our tools needs service or repair, one of our Authorized Repair Stations located throughout the United States can provide quick service or information.

In most cases, a WMH Tool Group Repair Station can assist in authorizing repair work, obtaining parts, or perform routine or major maintenance repair on your POWERMATIC product.

For the name of an Authorized Repair Station in your area, please call 1-800-274-6848, or visit our web site at www.wmhtoolgroup.com

More Information

Remember, WMH Tool Group is consistently adding new products to the line. For complete, up-to-date product information, check with your local WMH Tool Group distributor, or visit our web site at www.wmhtoolgroup.com

WMH Tool Group Warranty

WMH Tool Group makes every effort to assure that its products meet high quality and durability standards and warrants to the original retail consumer/purchaser of our products that each product be free from defects in materials and workmanship as follows: 1 YEAR LIMITED WARRANTY ON ALL PRODUCTS UNLESS SPECIFIED OTHERWISE. This Warranty does not apply to defects due directly or indirectly to misuse, abuse, negligence or accidents, normal wear-and-tear, repair or alterations outside our facilities, or to a lack of maintenance.

WMH TOOL GROUP LIMITS ALL IMPLIED WARRANTIES TO THE PERIOD SPECIFIED ABOVE, BEGINNING FROM THE DATE THE PRODUCT WAS PURCHASED AT RETAIL. EXCEPT AS STATED HEREIN, ANY IMPLIED WARRANTIES OR MERCHANTABILITY AND FITNESS ARE EXCLUDED. SOME STATES DO NOT ALLOW LIMITATIONS ON HOW LONG THE IMPLIED WARRANTY LASTS, SO THE ABOVE LIMITATION MAY NOT APPLY TO YOU. IN NO EVENT SHALL WMH TOOL GROUP BE LIABLE FOR DEATH, INJURIES TO PERSONS OR PROPERTY, OR FOR INCIDENTAL, CONTINGENT, SPECIAL, OR CONSEQUENTIAL DAMAGES ARISING FROM THE USE OF OUR PRODUCTS. SOME STATES DO NOT ALLOW THE EXCLUSION OR LIMITATION OF INCIDENTAL OR CONSEQUENTIAL DAMAGES, SO THE ABOVE LIMITATION OR EXCLUSION MAY NOT APPLY TO YOU.

To take advantage of this warranty, the product or part must be returned for examination, postage prepaid, to an Authorized Repair Station designated by our office. Proof of purchase date and an explanation of the complaint must accompany the merchandise. If our inspection discloses a defect, we will either repair or replace the product at our discretion, or refund the purchase price if we cannot readily and quickly provide a repair or replacement. We will return the repaired product or replacement at WMH Tool Group's expense, but if it is determined there is no defect, or that the defect resulted from causes not within the scope of WMH Tool Group's warranty, then the user must bear the cost of storing and returning the product. This warranty gives you specific legal rights; you may also have other rights, which vary from state to state.

WMH Tool Group sells through distributors only. Members of the WMH Tool Group reserve the right to effect at any time, without prior notice, alterations to parts, fittings and accessory equipment, which they may deem necessary for any reason whatsoever.

Table of Contents

Warranty and Service.....	2
Table of Contents.....	3
Warnings.....	4
Introduction.....	6
Specifications.....	6
Unpacking.....	7
Contents of the Mortiser Carton.....	7
Contents of the Stand Carton.....	7
Assembly.....	8
Securing Machine to Stand.....	8
Wooden Table.....	8
Operating Handle.....	8
Installing Chisel and Bit.....	9
Work Stop.....	9
Electrical.....	10
Power Connection.....	10
Grounding Instructions.....	10
Operating Controls.....	10
Start/Stop Switch.....	10
Adjustments.....	11
90° Chisel to Worktable Calibration.....	11
Chuck Extension Adaptor.....	11
Depth Stop Rod Adjustment.....	12
Table Position.....	12
Forward/Backward Table Movement.....	12
Lateral Table Movement.....	12
Table Tilt Control.....	12
Chisel Parallel to Workpiece.....	13
Operation.....	13
Maintenance.....	14
General.....	14
Sharpening Chisel and Bit.....	14
Bit.....	14
Chisel.....	14
Lubrication.....	15
Parts.....	15
Replacement Parts.....	15
719T Mortiser Parts List.....	16
719T Mortiser Assembly.....	18
719T Mortiser Stand Parts List.....	19
719T Mortiser Stand Assembly.....	19
Optional Accessories.....	20

Warnings

1. Read and understand the entire owners manual before attempting assembly or operation.
2. Read and understand the warnings posted on the machine and in this manual. Failure to comply with all of these warnings may cause serious injury.
3. Replace the warning labels if they become obscured or removed.
4. This mortiser is designed and intended for use by properly trained and experienced personnel only. If you are not familiar with the proper and safe operation of a mortiser, do not use until proper training and knowledge have been obtained.
5. Do not use this mortiser for other than its intended use. If used for other purposes, WMH Tool Group disclaims any real or implied warranty and holds itself harmless from any injury that may result from that use.
6. Always wear approved safety glasses/face shields while using this mortiser. Everyday eyeglasses only have impact resistant lenses; they are not safety glasses.
7. Before operating this mortiser, remove tie, rings, watches and other jewelry, and roll sleeves up past the elbows. Remove all loose clothing and confine long hair. Non-slip footwear or anti-skid floor strips are recommended. Do **not** wear gloves.
8. Wear ear protectors (plugs or muffs) during extended periods of operation.
9. Some dust created by power sanding, sawing, grinding, drilling and other construction activities contain chemicals known to cause cancer, birth defects or other reproductive harm. Some examples of these chemicals are:
 - Lead from lead based paint.
 - Crystalline silica from bricks, cement and other masonry products.
 - Arsenic and chromium from chemically treated lumber.Your risk of exposure varies, depending on how often you do this type of work. To reduce your exposure to these chemicals, work in a well-ventilated area and work with approved safety equipment, such as face or dust masks that are specifically designed to filter out microscopic particles.
10. Do not operate this machine while tired or under the influence of drugs, alcohol or any medication.
11. Make certain the switch is in the **OFF** position before connecting the machine to the power supply.
12. Make certain the machine is properly grounded.
13. Make all machine adjustments or maintenance with the machine unplugged from the power source.
14. Remove adjusting keys and wrenches. Form a habit of checking to see that keys and adjusting wrenches are removed from the machine before turning it on.
15. Keep safety guards in place at all times when the machine is in use. If removed for maintenance purposes, use extreme caution and replace the guards immediately.
16. Make sure the mortiser is firmly secured to the floor before use.
17. Check damaged parts. Before further use of the machine, a guard or other part that is damaged should be carefully checked to determine that it will operate properly and perform its intended function. Check for alignment of moving parts, binding of moving parts, breakage of parts, mounting and any other conditions that may affect its operation. A guard or other part that is damaged should be properly repaired or replaced.
18. Provide for adequate space surrounding work area and non-glare, overhead lighting.
19. Keep the floor around the machine clean and free of scrap material, oil and grease.
20. Keep visitors a safe distance from the work area. **Keep children away.**



Warnings

21. Make your workshop child proof with padlocks, master switches or by removing starter keys.
22. Give your work undivided attention. Looking around, carrying on a conversation and “horse-play” are careless acts that can result in serious injury.
23. Maintain a balanced stance at all times so that you do not fall or lean against the chisel and drill bits or other moving parts. Do not overreach or use excessive force to perform any machine operation.
24. Use the right tool at the correct speed and feed rate. Do not force a tool or attachment to do a job for which it was not designed. The right tool will do the job better and safer.
25. Use recommended accessories; improper accessories may be hazardous.
26. Maintain tools with care. Keep chisel and drill bits sharp and clean for the best and safest performance. Follow instructions for lubricating and changing accessories.
27. Make sure the work piece is securely attached or clamped to the table. Never use your hand to hold the work piece.
28. Turn off the machine before cleaning. Use a brush or compressed air to remove chips or debris — do not use your hands.
29. Do not stand on the machine. Serious injury could occur if the machine tips over.
30. Never leave the machine running unattended. Turn the power off and do not leave the machine until it comes to a complete stop.
31. Remove loose items and unnecessary work pieces from the area before starting the machine.

Familiarize yourself with the following safety notices used in this manual:

CAUTION

This means that if precautions are not heeded, it may result in minor injury and/or possible machine damage.

WARNING

This means that if precautions are not heeded, it may result in serious injury or possibly even death.

- - SAVE THESE INSTRUCTIONS - -

Introduction

This manual is provided by POWERMATIC covering the safe operation and maintenance procedures for a Model 719T Tilting Table Hollow Chisel Mortiser. This manual contains instructions on installation, safety precautions, general operating procedures, maintenance instructions and parts breakdown. This machine has been designed and constructed to provide years of trouble free operation if used in accordance to instructions set forth in this manual. If there are any questions or comments, please contact either your local supplier or WMH Tool Group. WMH Tool Group can also be reached at our web site: www.wmhtoolgroup.com.

Specifications

Model No.....	719T
Stock No.....	1791264K
Stock No – Mortiser only.....	2474002T
Stock No – Stand only.....	6294235T
Motor.....	1 HP, 1 PH, 115V/230V, Prewired 115V
Spindle speed.....	1725 RPM
Table tilt.....	0° to 35°
Chisel capacity.....	1/4" - 1"
Chisel shank diameters.....	5/8", 3/4", 1-1/8"
Maximum chisel stroke.....	10-3/4"
Maximum head stroke.....	6"
Chisel center to fence distance.....	4"
Chuck capacity.....	1/2"
Bushing size.....	5/8", 3/4", 1-1/8"
Longitudinal table travel.....	15-1/2"
Cross table travel.....	4"
Table size.....	7" x 20-1/4"
Fence size.....	4-1/2" x 20-1/4"
Base size.....	14" x 16"
Overall height on base.....	60"
Overall dimensions.....	21-1/4" L x 21-5/8" W x 74" H
Weight - Mortiser.....	Net weight 230 lbs., Gross weight 242 lbs.
Weight - Stand.....	Net weight 46 lbs., Gross weight 50 lbs.

The above specifications were current at the time this manual was published, but because of our policy of continuous improvement, WHM Tool Group reserves the right to change specifications at any time and without prior notice, without incurring obligations.

Unpacking

Remove mortiser and stand from the shipping cartons. Check for damage and ensure all parts are intact. Any damage should be reported immediately to your distributor and shipping agent. Read the manual thoroughly to familiarize yourself with the correct assembly and maintenance procedures and proper safety precautions.

Contents of the Mortiser Carton

- 1 ea – Mortiser (not shown)
1. 1 ea – Wooden Table
2. 2 ea – M6 x 20 Phillips Head Screws
3. 2 ea – Handwheel Handles
4. 1 ea – Chuck Key
5. 1 ea – Chuck Removal Wrench
6. 1 ea – 23mm Box Wrench
7. 1 ea – Operating Handle
8. 1ea – Chuck Extension Adaptor
9. 2 ea – Chisel Bushings (3/4", 1-1/8")

Note: The Mortiser also comes with a 5/8" bushing already installed.

10. 1 Work Stop Assembly

Contents of the Stand Carton

- 1 Stand (not shown)
- 1 Hardware package – (4) M8 x 45 Hex Cap Screws, (4) M8 Lock Washers (not shown)

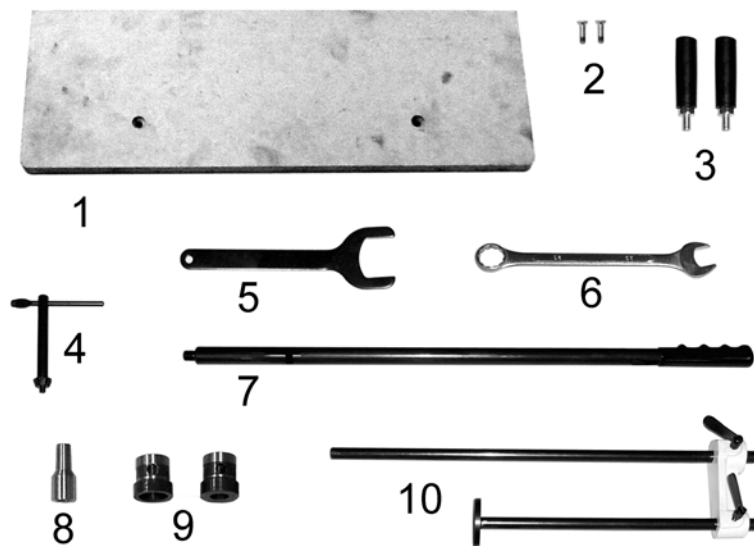

Contents of the Mortiser Carton

Assembly

⚠WARNING Do not connect the machine to power source until completely assembled. Read and understand the entire manual.

Securing Machine to Stand

The mortiser should be secured to the stand with four M8 x 45 hex cap screws and M8 lock washers (provided) using the holes in the base. Make sure there is enough room on each side of the mortiser for the size stock you plan to use.

Wooden Table

Referring to Figure 1:

1. Place the wooden table (A) in position on the slide (B).
2. Secure with two Phillips head screws provided (C).

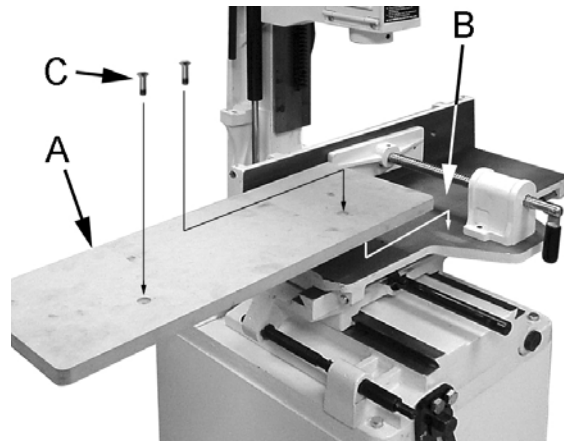

Figure 1

Operating Handle

Referring to Figure 2:

1. Fasten *operating handle* (A) to the *hub* (B) and tighten with a 14mm open-end wrench.
2. Raise mortising machine head to the up position by moving the *operating handle* (A) up.

Note: The handle assembly is spring-loaded and can be repositioned by pulling out the *hub* (B) and repositioning it on the pinion shaft (C).

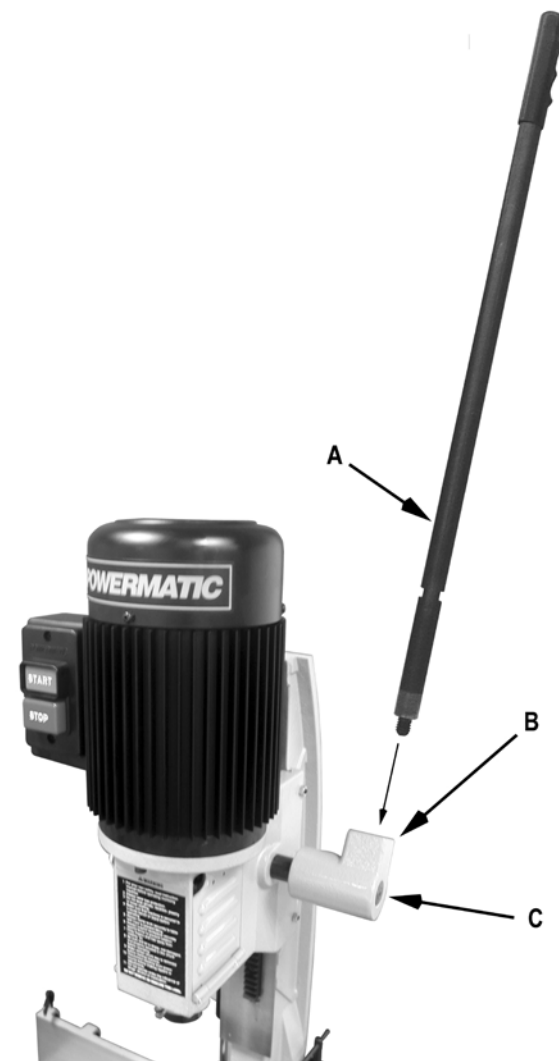

Figure 2

Installing Chisel and Bit

Referring to *Figure 3*:

1. Loosen the *lock screw*.
2. Insert the chisel *bushing* into the head with the hole facing forward to line up with the *lock screw*. Screw in the *lock screw* just enough so the screw extends into the hole of the *bushing*, holding it in place.
3. Push the *chisel* up through the *bushing*, bringing it to rest against the shoulder of the *bushing*. Then lower the *chisel* approximately 1/16" to 3/16", depending on the type of wood being worked.

Note: Set the *slot* in the side of the *chisel* to the *left* or *right*, if the workpiece is to be moved laterally and *front* or *back* if it is to be moved from front to back. Move the workpiece so that the slot in the chisel is releasing chips into the *already cut* part of the workpiece (see *Figure 14*).

4. Tighten the *lock screw* to hold the *chisel* in place.
5. Push the *bit* up through the chisel opening as far as it will go. Lock the drill bit in place with the *chuck key*.
6. Loosen the *lock screw* and push the *chisel* up against the *bushing*, then tighten the *lock screw*. This should provide the proper distance between the points of the *chisel* and the *bit*.

Note: This would be a good place to make sure that the chisel is parallel to the workpiece. See the *Chisel Parallel to Workpiece* section.

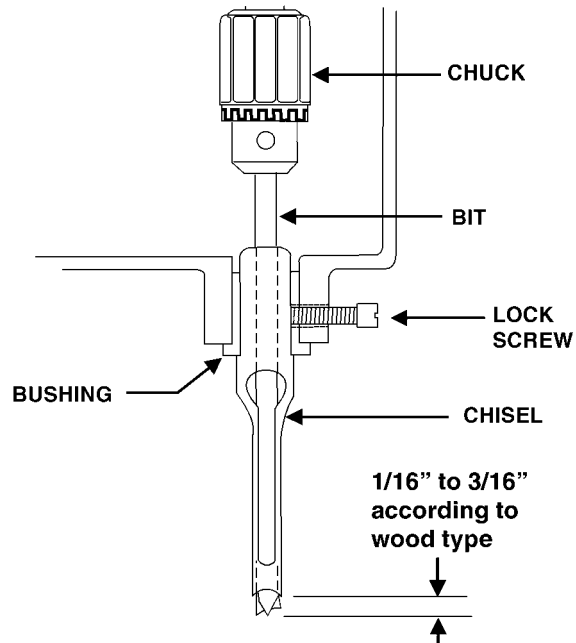

Figure 3

Work Stop

The work stop can be mounted to either end of the table through the holes in the back of the table, as shown in *Figure 4*. It is tightened into place by means of thumbscrews.

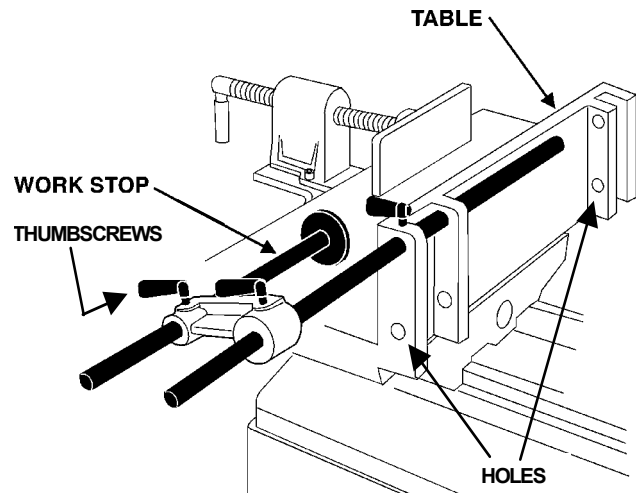

Figure 4

Electrical

Power Connection

⚠ WARNING Do not operate this machine in damp locations.

A separate electrical circuit should be used for your machines. This circuit should not be less than #12 wire and should be protected with a 20 Amp time lag fuse. If an extension cord is used, use only 3-wire grounding type plugs and matching receptacle, which will accept the machine's plug. Before connecting the machine to the power line, make sure the switch is in the *Off* position and be sure that the electric current is of the same characteristics as indicated on the machine. All line connections should make good contact. Running on low voltage will damage the machine.

Grounding Instructions

⚠ WARNING This machine must be grounded while in use to protect the user from shock

In the event of a malfunction or breakdown, grounding provides a path of least resistance for electric current to reduce the risk of electric shock.

If you are not sure whether your outlet is properly grounded, consult a qualified electrician.

Referring to Figure 5: As received from the factory, your mortiser is ready to run at 115-volt operation. This mortiser is intended for use on a circuit that has an outlet and a plug that looks like the one illustrated in (A). A temporary adaptor, which looks like the adaptor shown in (B), may be used to connect this plug to a two-pole receptacle if a properly grounded outlet is not available. The temporary adaptor should only be used until a properly grounded outlet can be installed by a qualified electrician. This adaptor is not applicable in Canada. The green colored rigid ear, lug, or tab, extending from the adaptor, must be connected to a permanent ground such as a properly grounded outlet box.

Operating Controls

Start/Stop Switch

Referring to Figure 6: The *Start/Stop Switch* is located to the left of the motor on the side of the mortiser. To turn the mortiser on press the green *START* (A) button. To stop the mortiser, push the red *STOP* (B) button.

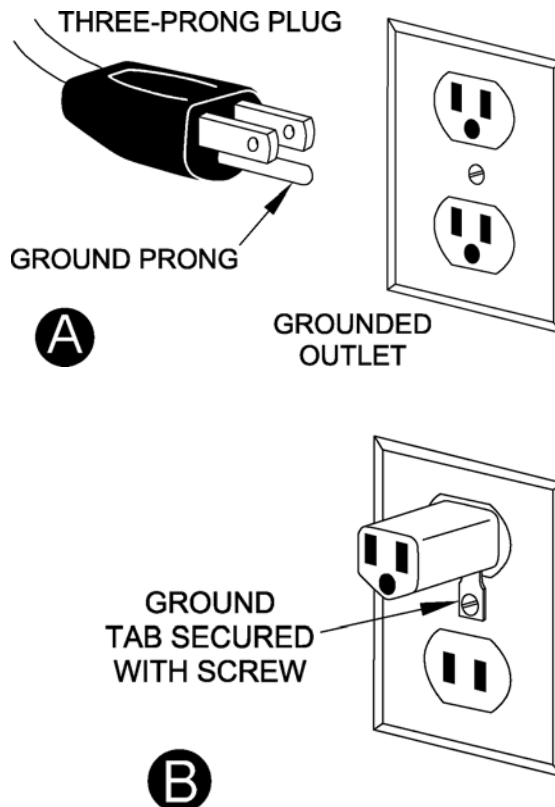

Figure 5



Figure 6

Adjustments

90° Chisel to Worktable Calibration

Referring to Figure 7:

Place a square (E) so it rests against the worktable (B) and chisel (A). If the *chisel to table angle* is 90°, no calibration is necessary.

If calibration is required:

1. Loosen the *bolt* (C) that allows the *tilting base* to pivot.

CAUTION The tilting base is heavy. If raised, take extra precaution not to let it drop on hands or fingers. Injury can result.

2. Adjust the *adjustment screws* (F) until the *chisel to table angle* is 90°. Calibration is then complete.
3. Retighten the bolt (C).

Upon completion, make sure that the pointer points to 0°. Calibrate if necessary.

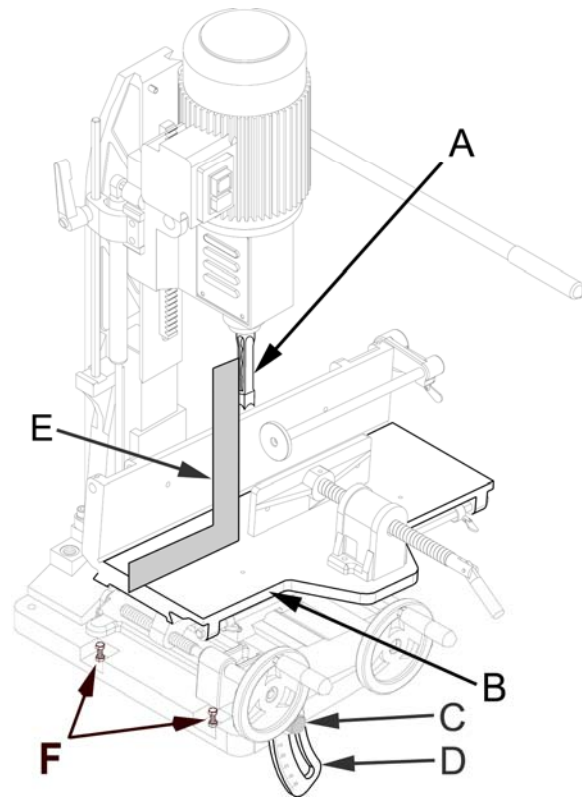

Figure 7

Chuck Extension Adaptor

The provided *Chuck Extension Adaptor* (C) is intended to lower the chuck for use with *after-market chisels* (chisels other than the *POWERMATIC* brand) that may require a spacer due to varying lengths in shanks.

To install the adaptor, first remove the *chisel* and *bit* (see the *Installing Chisel and Bit* section). Then, referring to Figure 8:

1. Loosen the *lock screw* (E) enough to remove the *chisel bushing* (F).
2. Remove the *chisel bushing* (F). This is necessary to provide enough clearance when installing the chuck and extension adaptor.
3. Unscrew the *chuck release nut* (A) counterclockwise with the wrench provided to force the *chuck* (D) off the *shaft* (B).

It may be necessary to hold the shaft stationary while turning the nut. This can be done by inserting the *chuck key handle* into the hole in the *chuck* and allowing it to wedge against the edge of the headstock.

4. When the chuck is off, return the *chuck release nut* (A) to its original position on the *shaft* (B).
5. Push the *adaptor* (C) into the *chuck* (D). Then push this assembly onto the motor *shaft* (B).

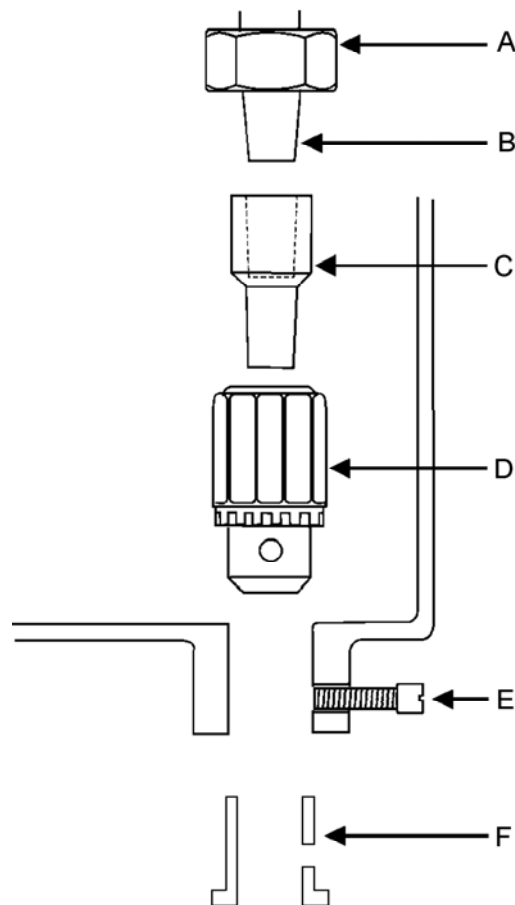

Figure 8

- Reinstall the *chisel bushing* (F) and secure it loosely with the *lock screw* (E).
- Reinstall the *chisel* and *bit* (refer to the *Installing Chisel and Bit* section).

Depth Stop Rod Adjustment

Referring to Figure 9:

A *depth stop rod* (A) is provided to limit the depth of the chisel. To adjust:

- Loosen *lock lever* (B) and lower the *depth stop rod* (A) until it comes to rest on top of the *column stop* (C).
- With the *operating handle* (see Figure 2) lower the *head* (E) until the *chisel* (D) is at the desired depth.
- The *depth stop rod* (A) should still be resting on top of the *column stop* (C).
- Tighten the *lock lever* (B).

Table Position

The 719T Mortiser is equipped with two handwheels for table (E, Fig. 10) positioning. In addition, the table can be tilted up to 35° for angle mortising.

Forward/Backward Table Movement

- Loosen the *wing screw* on the right side of the *middle base* under the table.
- Turn the *handwheel* (A, Fig. 10) to move the table the *forward* or *backward*.
- Tighten the wing screw.

Lateral Table Movement

- Loosen the *wing screw* located on the back of the *middle base* located near the column.
- Turn the *handwheel* (B, Fig. 10) to move the table to the *right* or *left*.
- Tighten the *wing screw*.

Table Tilt Control

CAUTION The tilt table is heavy. When raised, take extra precaution not to let it drop on hands or fingers. Injury can result.

- Loosen bolt (C, Fig. 10) with the 23mm wrench provided.
- Pivot the table to adjust the angle up to 35° using the scale (D) on the tilt bracket as a guide.
- Tighten the *bolt* (C).

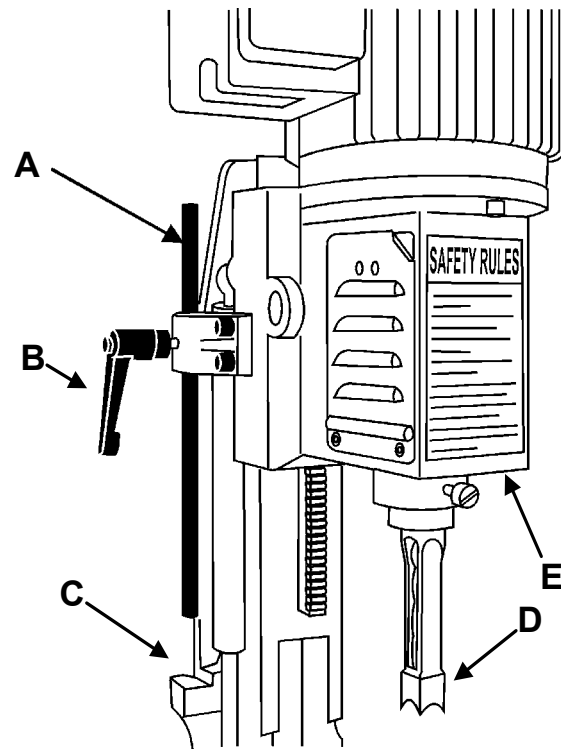

Figure 9

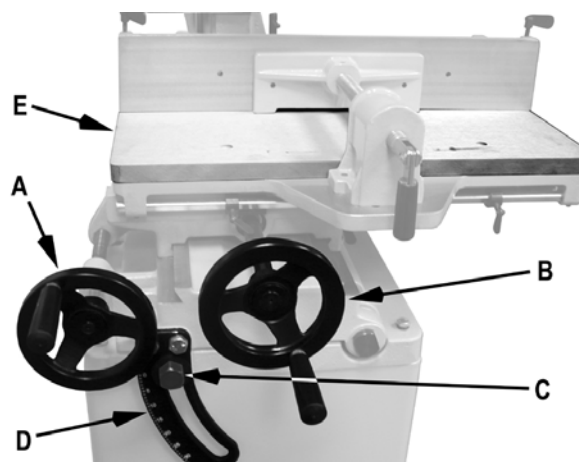

Figure 10

Chisel Parallel to Workpiece

Referring to Figure 11:

The chisel can be adjusted parallel to the workpiece as follows:

1. With the left *handwheel* (A), move the table back far enough to insert the *workpiece* (B) between the *chisel* (D) and *fence*.
2. Loosen the *lock screw* (C). This will allow the chisel to rotate.
3. Bring the table forward with the *handwheel* (A) until the *workpiece* (B) rests against the back surface of the *chisel* (D), but do not force.

Further adjust the chisel by hand if needed.

4. Tighten the *lock screw* (C).

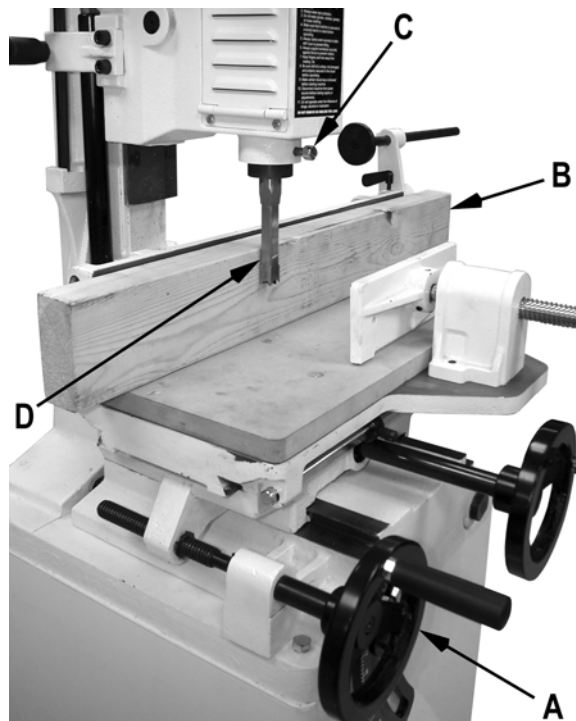

Figure 11

Operation

1. Set the *depth stop* (A, Fig. 12) to the required depth of cut. Refer to the *Depth Stop Rod Adjustment* section.
5. Place workpiece on table (C, Fig. 13) and clamp it with the vise (A, Fig. 13). Use the left handwheel (D, Fig. 13) to move table forward or backward to suit the position of the mortise on the workpiece.
6. Adjust the table stops according to the length of cut required, then tighten the *thumbscrews* (B, Fig. 13).

WARNING Before turning the machine on, verify that the chuck key is not in the chuck.

7. Turn on the machine and feed the *chisel and bit* steadily into workpiece by pulling down the *operating handle*.

Note: The rate of feed must be fast enough to prevent burning at the tip of the bit, but not so fast as to cause the machine to slow or stall. The different rates of feed for different woods must be learned through experience.

8. After the first cut, the workpiece is moved along with the right handwheel (E, Fig. 13) for each successive cut. The direction of movement must allow the chips to clear freely. Move the workpiece so that the slot in the chisel is releasing chips into the already cut part of the workpiece (Figure 14).

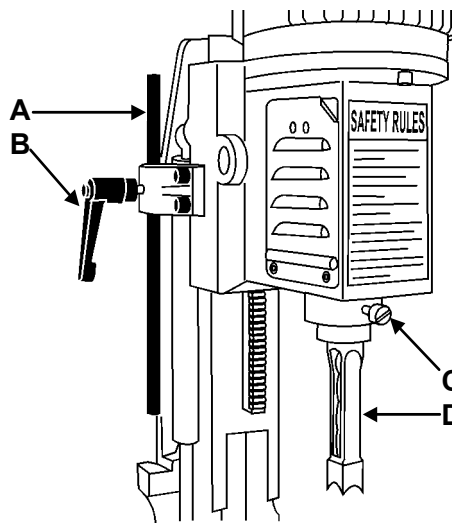

Figure 12

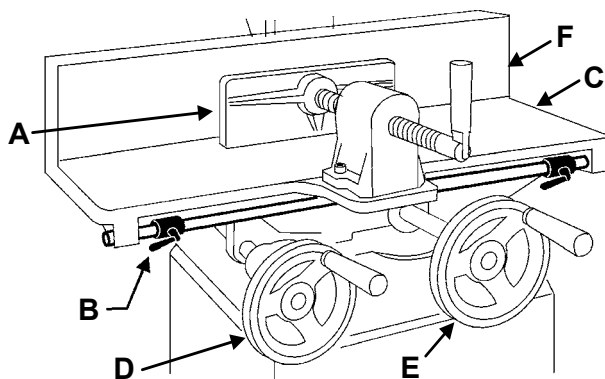

Figure 13

CAUTION Do not have the chisel slot against the blind end of the mortise, as the chips will not be able to clear the chisel. This can cause overheating and possible breakage of chisel or bit.

When cutting deep mortises, make the cut in several stages of approximately 1" each, to allow chips to clear. To prevent breakout at the back of the workpiece when cutting through mortises, use a piece of scrap material under the workpiece as support.

Maintenance

WARNING Before any intervention on the machine, disconnect it from the electrical supply by pulling out the plug or switching off the main switch! Failure to comply may cause serious injury.

General

A coat of paste wax applied to the table and column will help to keep the surfaces clean.

If the power cord is worn, cut, or damaged in any way, have it replaced immediately.

The Mortiser requires only minor maintenance, such as cleaning and lubrication and routine adjustment and sharpening of the chisel and bit.

Dust the machine down after each use and, as necessary, use light applications of oil or grease to lubricate linkages, moving parts, etc.

Sharpening Chisel and Bit

The chisel and bit should be kept sharp for best performance. Blunt edges will give inaccurate mortises and can lead to overheating and breakage to chisel or bit. If chisel and bit are badly worn and become difficult to sharpen, they should be replaced.

Bit

Sharpen the bit by using a small, smooth file, following the original shape of the bit. File the inside edge of the spur, the sides of the brad point, and the cutting edge inwards toward the flute of the bit (Figure 15).

Do not file the outside edge of the spur, as this will affect the diameter of the bit.

Chisel

Sharpen the chisel with a mortise chisel cutter with the correct size pilot. (Pilot size will differ depending on the size of your chisel). Two or

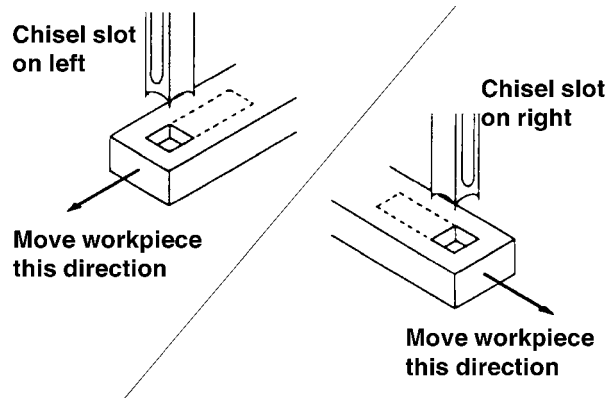

Figure 14

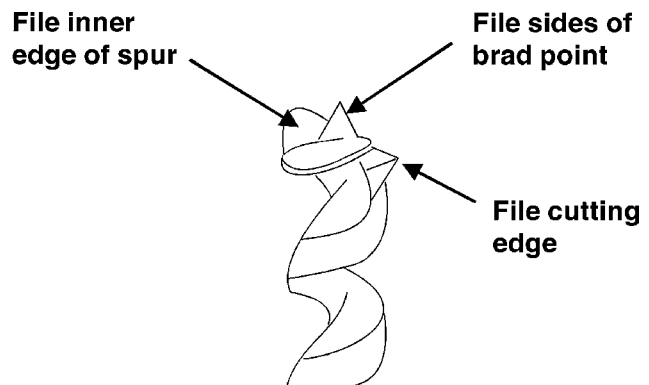

Figure 15

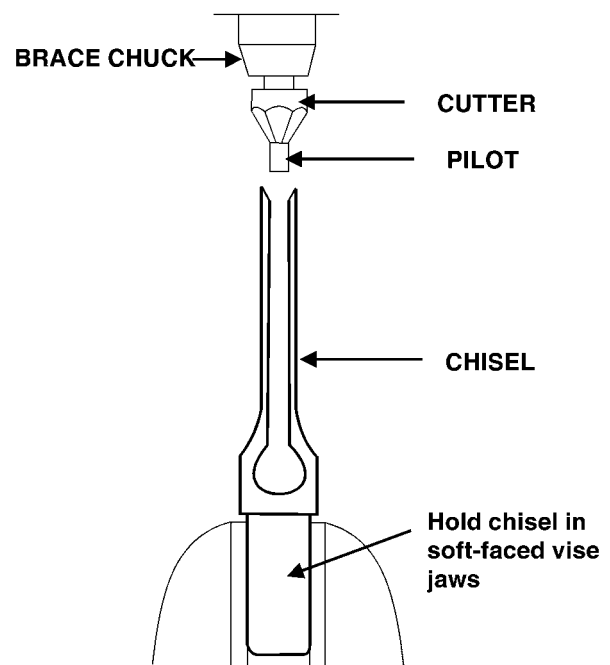

Figure 16

three turns of the cutter in a carpenter's brace chuck should be enough to sharpen the chisel, as shown in Figure 16.

Use a small, triangular, smooth file to relieve the inner corners of the chisel (Figure 17). Remove any burrs from the outside of the chisel with a fine oilstone.

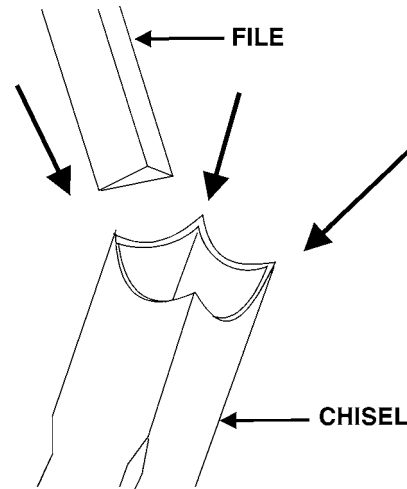

Figure 17

Lubrication

All of the ball bearings are packed with grease at the factory. They require no further lubrication.

Periodically grease the gears, racks, and table pivot points with a #2 tube grease.

Periodically clean and oil any exposed machine surfaces, such as: dove-tail ways and slides, and table surface.

Parts

Replacement Parts

Replacement parts are listed on the following pages. To order parts or reach our service department, call 1-800-274-6848 between 7:00 a.m. and 6:00 p.m. (CST), Monday through Friday. Having the Model Number and Serial Number of your machine available when you call will allow us to serve you quickly and accurately.

719T Mortiser Parts List

Index No.	Part No.	Description	Size	Qty
	2474002T	719T Mortiser Assy (Items 1 thru 120)		1
1	719T-101	Fixed Base		1
2	6294125	Base, Middle		1
3	6294126	Gib		1
4	TS-1523061	Socket Set Screw	M6×20	3
5	TS-1540041	Hex Nut	M6	9
6	6294129	Lead Screw		1
7	TS-1523031	Socket Set Screw	M6×10	4
8	6294131	Hand wheel		1
9	6294132	Shaft		1
10	6294133	Gear		1
11	6294134	C-Clip		1
12	6294135	Hand wheel		1
13	BB-6002ZZ	Bearing	6002ZZ	2
14	6294137	C-Clip		2
15	TS-1503041	Socket Head Cap Screw	M6×16	2
16	6294139	Stop Block		1
17	6294140	Gib		1
18	6294141	Main Table		1
19	TS-1523011	Socket Set Screw	M6×6	4
20	6294143	Setting Collar		2
21	6294144	Setting Rod		1
22	6294145	Wing Screw	M6×16	3
23	6294146	Rack		1
24	TS-1523071	Socket Set Screw	M6×25	6
25	6294148	Rear Length Setting Rod		1
26	6294149	Setting Length Block		1
27	6294150	Front Length Setting Rod		1
28	6294151	Wooden Table Insert		1
29	TS-2286201	Machine Screw, Flat Head, Phillips	M6×20	2
30	719T-130	Column		1
31	6294154	Wave Washer		2
32	6294155	Gib		1
33	6294156	Headstock		1
34	719T-134	Rack		1
35	TS-1503031	Socket Head Cap Screw	M6×12	4
36	6294159	Left Side Cover		1
37	6294160	Right Side Cover		1
38	TS-1533042	Machine Screw, Pan Head, Phillips	M5×12	4
39	6294162	Gear		1
40	6294163	Collar		1
41	6294164	Gear Shaft		1
42	6294165	Handle Hub		1
43	6294166	Spring		1
44	6294167	Washer		1
45	TS-1514021	Socket Head Flat Screw	M6×16	2
46	6294169	Handle		1
47	6294170	Handle Grip		1
48	6294171	Chuck	1/2" & Key	1
49	6294172	Motor, 1HP, 1PH, 115/230V		1
50	6294173	Switch Box		1
51	TS-081C052	Machine Screw, Pan Head, Phillips	#10-24 × 3/4	2
52	6294175	Switch		1
53	TS-0749042	Tapping Screw, Pan Head, Phillips	#8 × 5/8	2
54	TS-1503051	Socket Head Cap Screw	M6×20	3
55	6294178	Upper Cylinder Fitting		1
56	719T-156	Hydraulic Cylinder		1

Index No.	Part No.	Description	Size	Qty
57	6294180	C-Clip		2
58	6294181	Depth Setting Block		1
59	719T-159	Depth Setting Rod		1
60	6294183	Universal Handle		1
61	TS-1505041	Socket Head Cap Screw	M10×30	4
62	TS-2361101	Lock Washer	M10	8
63	6294186	Clamping Jaw		1
64	6294187	Clamping Block		1
65	6294188	Rapid Nut		1
66	6294189	Friction Toe		1
67	6294190	Spring		1
68	6294191	Rivet		1
69	6294192	Locking Screw		1
70	6294193	Stop Disc		1
71	TS-1504051	Socket Head Cap Screw	M8×25	2
72	TS-1550061	Flat Washer	M8	2
73	TS-1504061	Socket Head Cap Screw	M8×30	2
74	6294197	Chisel Locking Screw		1
75	6294198	Bushing	1-1/8"	1
75A	6294221	Bushing	3/4"	1
75B	6294222	Bushing	5/8"	1
76	6294199	Wheel Handle		2
77	6294200	Collar		1
78	6294201	E-Clip		2
79	6294202	Back Cover		1
80	TS-1532032	Machine Screw, Pan Head, Phillips	M4 × 10	6
81	6294204	Chuck Key		1
82	6294205	Chuck Key Holder		1
83	TS-2361051	Lock Washer	M5	1
84	TS-1502011	Socket Head Cap Screw	M5 × 8	1
85	6294208	Chuck Release Nut		1
86	6294209	Wave Washer		1
87	6294240	Cylinder Holder		2
88	6294211	Wrench (Chuck Removal)		1
89	6294212	Lower Cylinder Fitting		1
90	6294213	Wing Screw	M6 × 8	2
91	6294214	Roll Pin		1
92	6294215	Key	5 × 5 × 10	1
93	6294216	Key	5 × 5 × 12	1
94	6294217	Power Cord		1
95	6294223	Plastic Handle Sleeve		1
96	3005069	Chuck Extension Adaptor		1
97	JWP15-065	Wing Screw	M6×25	2
98	TS-0267051	Socket Set Screw	1/4-20 × 1/2	2
99	TS-2361081	Lock Washer	M8	2
100	TS-2360121	Flat Washer	M12	1
101	TS-2361061	Lock Washer	M6	3
102	6294243	Roll Pin	M6 × 16	1
103	6294244	Cord Strain Relief		1
104	719T-1104	Pin		1
105	719T-1105	Pointer		1
106	TS-1550041	Flat Washer	M6	1
107	TS-1534032	Machine Screw, Pan Head, Phillips	M6 x 10	1
108	719T-1108	Tilting Bracket		1
109	TS-155010	Flat Washer	M16	1
110	719T-1110	Shaft		1
111	719T-1111	Square Nut		1
112	TS-1490051	Hex Cap Screw	M8 x 30	2
113	TS-1540061	Hex Nut	M8	2

Index No.	Part No.	Description	Size	Qty
114	TS-1491021	Hex Cap Screw	M10 x 20	4
115	719T-1115	Tilting Bracket		1
116	TS-2342161	Hex Nut, Nylon Lock	M16	2
117	719T-1117	Wave Washer		2
118	719T-1118	Bolt		2
119	719T-1119	Tilting Base		1
120	719T-1120	Box Wrench	23mm	1

719T Mortiser Assembly

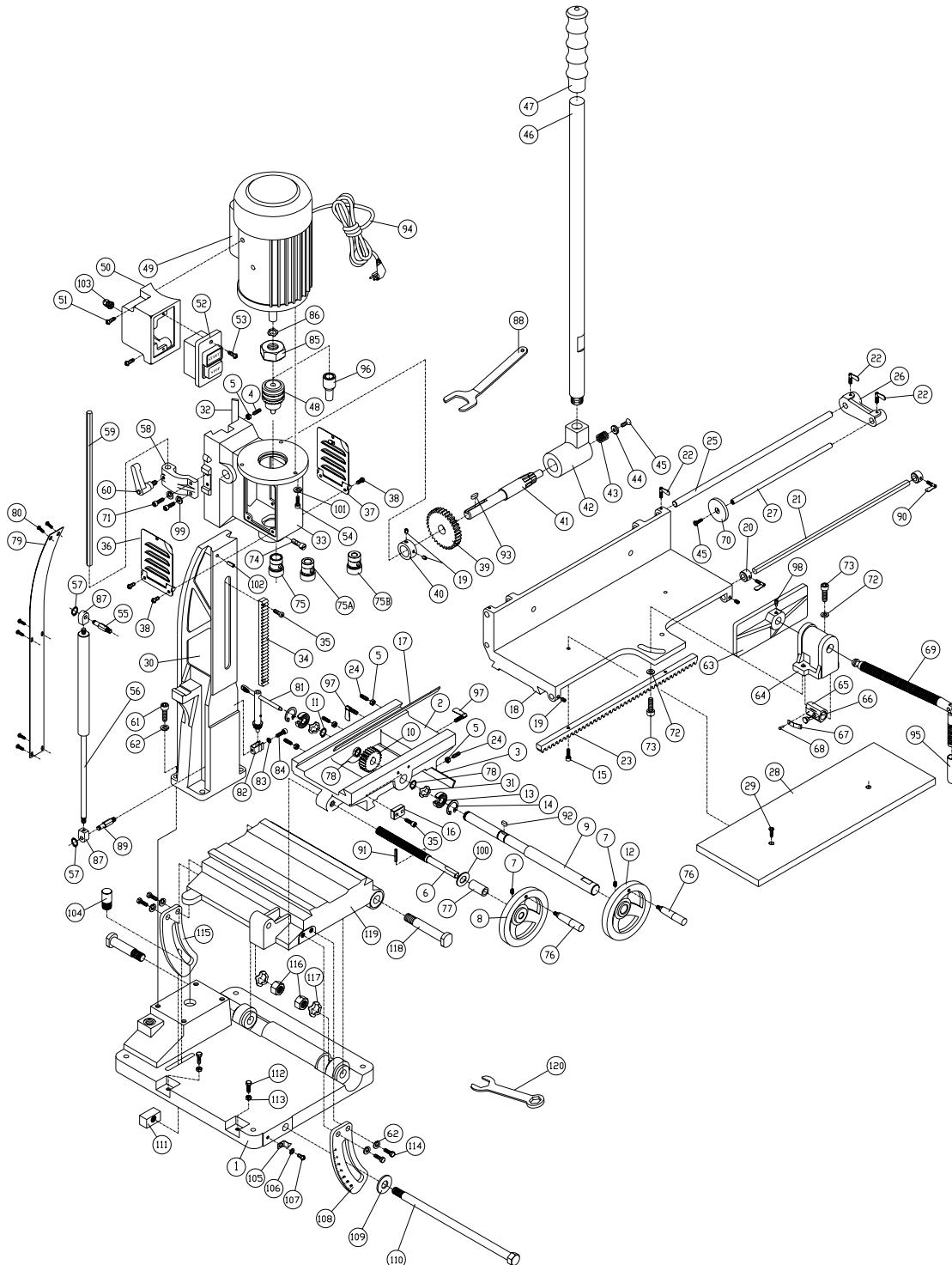

719T Mortiser Stand Parts List

Index No.	Part No.	Description	Size	Qty
.....	6294235T	Stand Assembly (Items 1 thru 8)		1
1	719T-201	Stand		1
2	719T-202	Shelf Cushion		1
.....	6294236	Door Assembly (Items 3 thru 6)		1
3	6294226	Door		1
4	6294227	Pin		2
5	6294228	Door Latch		1
6	TS-2171012	Machine Screw, Pan Head, Phillips	M4 x 6	2
7	TS-2361081	Lock Washer	M8	4
8	TS-1490081	Hex Cap Screw	M8 x 45	4

719T Mortiser Stand Assembly

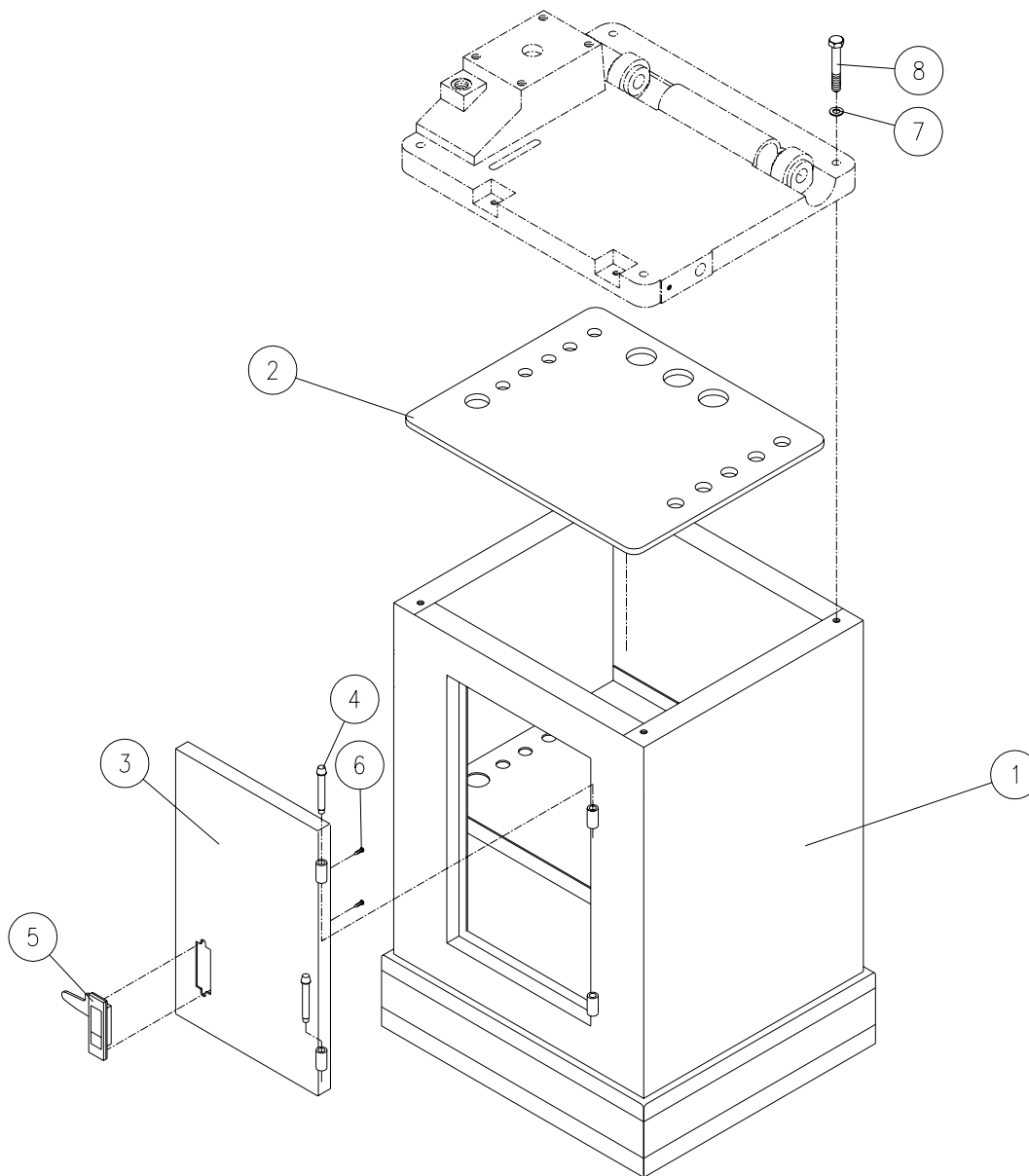

Optional Accessories

Index No.	Part No.	Description
	6294232	Chuck Extension Adaptor Kit (Items 1 thru 3)
1	6294210	Drill Adaptor Shaft
2	6294208	Chuck Release Nut
3	6294209	Spring Washer
4	6285526	Chisel & Bit, 1/4"
5	6285527	Chisel & Bit, 5/16"
6	6285528	Chisel & Bit, 3/8"
7	6285529	Chisel & Bit, 1/2"
8	6294245	Chuck & Key, 1/2"
9	6294198	Drill Bushing, 1-1/8"
10	6294221	Drill Bushing, 3/4"
11	6294222	Drill Bushing, 5/8"

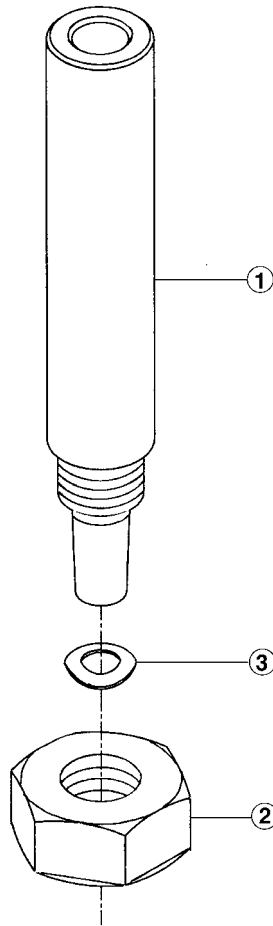

POWERMATIC®

WMH Tool Group
 2420 Vantage Drive
 Elgin, Illinois 60123
 Phone: 800-274-6848
www.wmhtoolgroup.com

Free Manuals Download Website

<http://myh66.com>

<http://usermanuals.us>

<http://www.somanuals.com>

<http://www.4manuals.cc>

<http://www.manual-lib.com>

<http://www.404manual.com>

<http://www.luxmanual.com>

<http://aubethermostatmanual.com>

Golf course search by state

<http://golfingnear.com>

Email search by domain

<http://emailbydomain.com>

Auto manuals search

<http://auto.somanuals.com>

TV manuals search

<http://tv.somanuals.com>