

brother
at your side

IPM Gear Motor

G3 Series
(Inline Shaft)

H2 Series
(Right Angle Shaft)

F3 Series
(Right Angle Hollow Bore)

Instruction Manual



G3 Series



H2 Series





F3 Series

Safe Operation

- The Gearmotor should be operated by a skilled and qualified person. The contents of this Instruction Manual should be carefully read and understood before operating this product.
- This Instruction Manual should be accessible to the person who operates this product.
- This Instruction Manual should be kept in a convenient place for the operator's easy reference.

Thank you for your purchasing this product.

Potential injuries and/or damage caused by mishandling equipment are classified into two categories, "Danger" and "Caution". The definitions of the classifications are given below with the corresponding graphic symbols.

 Danger	Mishandling the equipment may result in a dangerous situation and may lead to serious or fatal injury to personnel.
 Caution	Mishandling the equipment may result in a dangerous situation and may lead to medium to light injury or damage to the equipment.

Please be aware that even items marked with "CAUTION" may cause fatal accidents. Therefore, it is important to follow the instructions for every item described.

 Danger
<ul style="list-style-type: none">● Do not connect the IPM Motor directly to a commercial power supply. Failure to observe this caution may result in fire.● Do not operate the motor in explosive atmospheres or corrosive atmospheres. Failure to observe this warning may cause explosion, spark, fire, electric shock, physical injury, and/or damage to the equipment.● The operators in charge of transportation, installation, wiring, operation, maintenance, and inspection of the equipment should have enough knowledge and technical skill for the product. Failure to observe this warning may cause explosion, spark, fire, electric shock, physical injury, and/or damage to the equipment.● Do not repair or wire the equipment with the electric power on. Be sure to cut the power off the power supply before getting to work. Failure to observe this warning may cause electric shock.● When rotating the motor from the output shaft, insulate the terminal. Failure to observe this may cause electric shock.● If the equipment is to be used in a system for human transport, be sure to furnish it with a protective device for safety. Failure to observe this warning may cause physical injury and/or damage to the equipment by accidental falling.● If the equipment is to be used to drive an elevator, be sure to furnish it with safety devices to prevent the elevator from accidentally falling. Failure to observe this warning may cause physical injury and/or damage to the equipment.● Be sure not to get water or oil/grease into the brake unit. Failure to observe this warning may cause brake failure by decreasing brake holding torque.● Use the motor and driver with the specified combination. Failure to observe this warning may cause fire, and/or damage to the equipment.

Caution

- Do not use the gearmotor under conditions other than specified on the nameplate or product specifications. Failure to observe this warning may cause electric shock, physical injury and/or damage to the equipment.
- Do not touch the gearmotor or driver when the power is on or immediately after turning off the power, as their surfaces may be hot. Failure to follow this precaution may cause burns.
- Do not insert your fingers or any other object into the terminal box, lead wire exit, fan cover, or any other aperture of the gearmotor. Failure to observe this warning may result in electric shock, physical injury, fire and/or damage to the equipment.
- Do not use a damaged gearmotor. Failure to observe this warning may result in physical injury and/or fire.
- Do not remove the nameplate.
- The manufacturer will not warrant and will not be responsible for any product modified or repaired by the user.

Table of Contents

1 Check When Unpacking.....P.3	8 Specifications..... P.22
2 Transportation.....P.4	9 Inspection and Adjustment..... P.25
3 Installation.....P.4	10 Troubleshooting..... P.31
4 Connecting with Other Equipment...P.6	11 Storage..... P.32
5 Direction of Rotation..... P.14	12 Standard Terms and Conditions of Sale... P.33
6 Wiring..... P.16	
7 Operation..... P.21	

1 Check When Unpacking

When unpacking the carton, please check the followings items. If you have any problems or questions, please contact the dealer from which the product was purchased or Brother International Corp sales office.

Caution

Check whether the product is the product you ordered. Installing the wrong gearmotor on your equipment may cause physical injury and/or damage to the equipment.

- (1) The ordered product(s), the contents of the box or crate, and the rating indicated on the nameplate are correct.
(Type, Reduction Ratio, RPM, Horsepower or Watts, Voltage, etc.)
- (2) No accidental damage to the product during transportation has occurred.
- (3) Screws or nuts are not loose.
- (4) In case of a brake equipped gearmotor, be sure the rectifier is enclosed.
- (5) In case of F or F3 series hollow bore/shaft mount type be sure the bore safety cap is enclosed.

2 Transportation

Danger

When a product is lifted for transportation, be careful. If a product is dropped and lands on any part of your body it may cause serious injury.

Caution

- Avoid dropping products during transport. When an eyebolt or eyeplate is provided on a gearmotor or reducer, confirm it is secure before using it. After installing the gearmotor or reducer in the equipment do not hoist the entire machine using the eyebolt or eyeplate. Failure to observe this warning may cause physical injury and/or damage to the equipment.
- Before lifting the product confirm it's weight using the packing box, product catalog, or by weighing it. Use a lifting device that has enough capacity to handle the weight of the gearmotor. Failure to observe this warning may cause physical injury or damage the equipment.
- If the product is packed in a wooden crate, please do not use a forklift to lift it from the bottom. The crate is not designed for use with a forklift in that manner. If using a forklift, please use a belt to lift the wooden box from the top.

3 Installation

Proper installation of a product will ensure reliable performance and maximum life.

Caution

- Do not place any flammable object near the gearmotor. Failure to observe this warning may cause fire.
- Do not allow interference with the ventilation of the gearmotor. Be sure to observe the spacing requirements for adequate air flow around the gearmotor. In the case of a fan cooled model, do not block the vent holes on the fan cover. Failure to observe this warning may result in abnormal overheating and/or injury or fire.
- Do not step on a gearmotor. Do not use a gearmotor as a grip to hoist yourself onto a machine. Failure to observe this warning may cause physical injury.
- Do not touch the edge of the shaft of the gearmotor or the key groove of the bore with your bare hands. Failure to observe this warning may cause physical injury.
- Food machine regulations may prohibit the possibility of oil or grease getting into the food area. If this is the case, please use a drip pan to prevent lubrication from getting into the food area. Alternatively, please request that appropriate food grade lubricants are applied.
- Leaking lubrication may cause products to fail.
- There is possibility scatter the wear debris or iron powders. In case of installing to equipment which will have any issue due to contamination of foreign substance such as food equipment, please install preventive equipment. This could harm the products.
- Vibrations resulting from improper installation of the gearmotor or from other sources should be under 0.5G.

① Proper location for installation

	IP40, IP44 (Indoor Type)	IP65 (Outdoor Type)
Ambient Temperature	-10°C to 40°C	-10°C to 40°C
Ambient Humidity	85 % max. (Non Condensing)	100 % max. (Non Condensing)
Altitude	Sea level to 1,000 m max.	Sea level to 1,000 m MAX
Environment	Well-ventilated place free from corrosive gas, explosive gas vapor and/or dust.	Well-ventilated place free from corrosive gas, explosive gas vapor and/or dust. Operation in water or in the high-hydrostatic pressure environment is not permitted.
Installation Location	Indoors	Indoors and/or Outdoors

② Direction of Installation

This product can be installed in any direction due to the grease lubrication system.

③ Method for Installation

a) Mounting a foot or flange type with a shaft.

- Secure the product with four bolts on a flat and machined surface free from vibration.
- Roughness of the mounting surface should be less than 0.3mm.

b) Mounting a hollow bore/shaft mount type.

- The driven shaft should be large enough and supported such that it can handle the weight of the gearmotor or reducer.
- Forces other than the turning or reactive force should not be imposed on the torque arm.
- For frequent start/stops or forward/reverse secure the torque arm with bolts to keep it axially secure.

④ Tightening Torque

Bolt Size	Tightening Torque (N·m) {(kgf·m)}
M 8	13 { 1.3 }
M10	25 { 2.6 }
M12	44 { 4.5 }
M14	69 { 7.0 }
M16	108 { 11.0 }
M20	294 { 30.0 }

4 Connecting with Other Equipment

Danger

A plastic bore cover is supplied with F3 type unit cover the exposed rotating bore. If you cannot secure the safety cover supplied, please prepare a cover yourself. Failure to cover the exposed rotating bore may result in damage to the equipment or injury.

Caution

- When connecting the gearmotor to a load with a chain or belt, make sure of the shaft parallel alignment is precise. Make sure the belt/chain tension is properly adjusted and pulleys or sprockets are parallel.
- When direct coupling, make sure the concentric alignment of shafts is precise.
- Before operation, make sure the set screws for the sprockets, pulleys or coupling are securely tightened. Failure to observe this warning may cause serious injury and/or damage to the equipment.
- Safety guards should be furnished around rotating parts and securely in place before starting the equipment.
- Do not over tension chain or belts. Damage to the gearmotor may occur due to excessive overhung load.
- Avoid excessively rigid direct couplings as damage may occur to the bearings due to high overhung load.

To attach the connecting devices (coupling, sprocket, pulley, gear, etc.) to the reducer shaft, be sure to use specified keys and provide H7 or equivalent fit tolerance.

- When directly connected
 - Shaft center of the connecting machine } Must be aligned in a straight line.
 - Shaft center of the reducer }

- An example of gear coupling

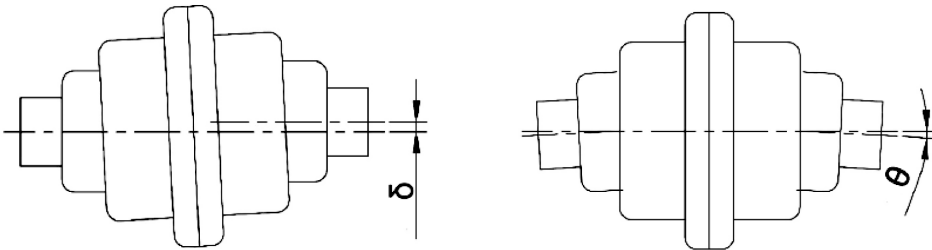

- The δ and θ should be minimized as much as possible.
- The δ and θ differ according to the type of coupling. Therefore, they should be within the allowable value defined by the respective manufacturer.
(Reference: In case of chain coupling, δ should be within 2% of the roller chain pitch and θ should be within 1 (Degree).)

■ Attaching Chains, V-Belts, Gears, etc.

(1) Shaft center of the connecting machine }
Shaft center of the reducer } Must be set parallel to each other.

(2) Chain/V-belt tension }
Gear engagement } Must be at right angle to shaft center.

(3) V-belt tension— If it is too tight, the bearing may become damaged.

Chain tension— If it is too tight, the bearing may become damaged. High impact force may also occur if it is too loose which would result in adverse effects on the reducer and application. The tension of the chain should be correctly adjusted.

Correct

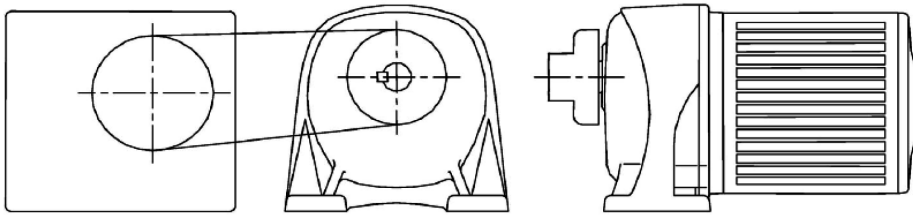

Application

● The tension of V-belt and chain are properly set, also pulley and sprocket are properly positioned.

Incorrect

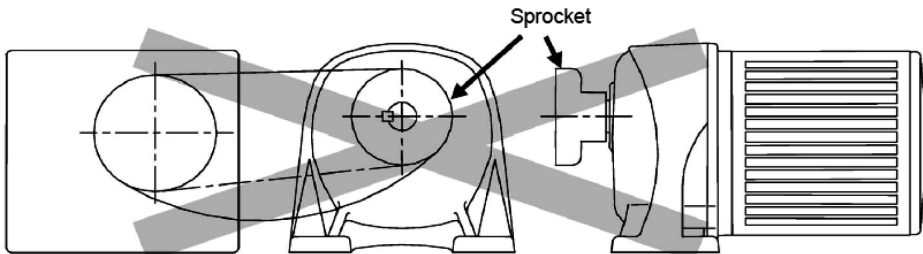

Application

● The chain is too loose. ● The sprocket is positioned in the reverse direction so that the load point moves to the shaft edge.

■ Installing and removing the hollow bore

● Attaching the Hollow Bore of the Reducer to the Drive Shaft

- [1] Coat the drive shaft surface and bore surface with a lubricant (molybdenum disulfide) suitable to the atmosphere in which they are used and connect the reducer to the drive shaft.
- [2] When used with uniform loads, a drive shaft tolerance of h7 is recommended. Additionally, when dealing with impact loads or large radial loads, make sure they fit each other lightly. The tolerance of the interior surface of the hollow bore is designed to be H8.
- [3] If the shafts are a tight fit, use a plastic hammer on the end of the hollow bore to insert it. When doing so, be sure not to hit the casing. If you make a jig like the one in the diagram below, drive shaft insertion will be easier.

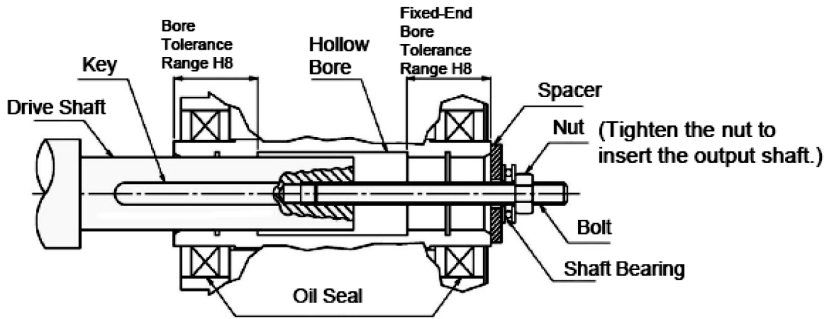

Fig. 1

(Customers need to provide their own spacer, nuts, bolts, keys and shaft bearings.)

- [4] For the length of the turn-stop key for the drive shaft, tolerance range H8 for the bore on the fixed side is recommended.
- [5] It is recommended that axial runout for the shaft be 0.05 mm or less at the shaft end. If major wobbling occurs during operation, it may have a negative effect on the reducer.

● Connecting the Reducer to the Drive Shaft

- [1] When there are steps on the drive shaft

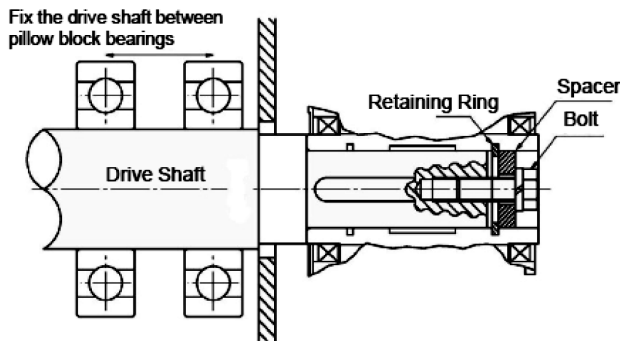

Fig. 2: Attachment Using a Spacer and Retaining Ring

(Customers need to provide their own spacer, bolts, and retaining rings.)

Note: Be careful when tightening the bolt, as tightening it too much can distort the shape of the retaining ring.

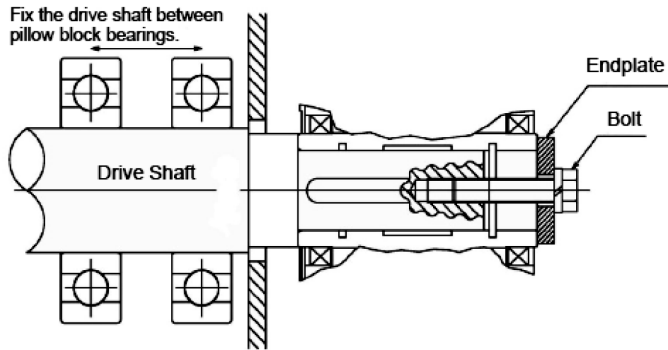

Fig. 3: Attachment Using an Endplate
(Customers need to provide their own endplates and bolts.)

[2] When there are no steps on the drive shaft

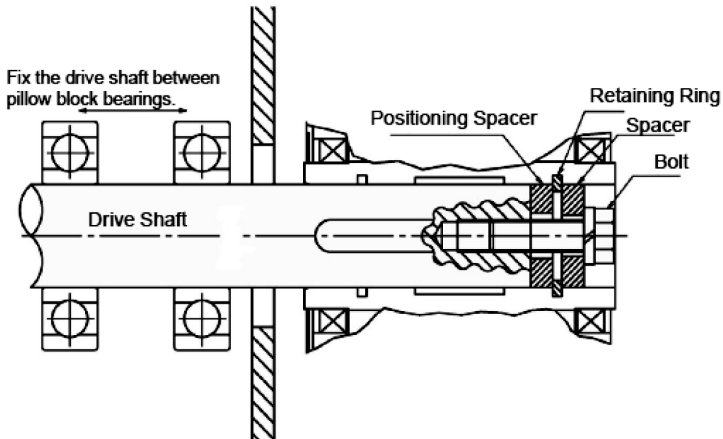

Fig. 4: Attachment Using a Spacer and Retaining Ring
(Customers need to provide their own spacer, positioning spacers, bolts, and retaining rings.)

Make sure there is a gap between the outer diameter of the spacer and the bore diameter of the hollow bore. If the fit is too tight and the outer diameter of the spacer is inaccurate, burning and axial runout of the drive shaft and hollow bore can result.

The positioning spacer is used to position the reducer. It is not required if you know the length of the drive shaft in advance. In addition, attaching the positioning spacer allows for smooth removal from the hollow bore. (Refer to Fig.5, p.10 for more on removal from the hollow bore.)

● Recommended Sizes for the Fixing Elements of the Drive Shaft

For the attachment of the hollow shaft in general use, we recommend you to refer to the dimensions shown on the right as a guide line for the strength when designing.

Recommended Sizes for the Fixing Elements of the Drive Shaft (mm)

Hollow Bore Hole Diameter	Bolt Size	Spacer Dimensions			C-Shaped Retaining Ring for Holes
		Outer Diameter	Inner Diameter	Width	
φ20	M6	φ19.5	φ7	3	20
φ25	M6	φ24.5	φ7	4	25
φ30	M8	φ29.5	φ9	5	30
φ35	M10	φ34.5	φ11	5	35
φ45	M10	φ44.5	φ11	5	45
φ50	M12	φ49.5	φ13	6	50
φ55	M12	φ54.5	φ13	6	55

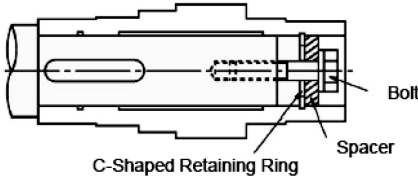

● Drive Shaft Length

Make sure the drive shaft reaches both ends of L1. (See figure at right.) However, look at the dimension leeway for spacers in the section titled "Removal from the Hollow Bore."

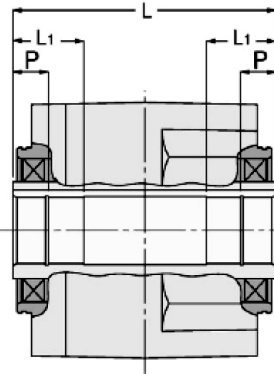

● Drive Shaft Key Length

The length of the key should be at least 1.5 times the width of the hollow bore. Additionally, the key is inserted in such a position that at least half its length is in L1. (See figure at right.)

● Removal from the Hollow Bore

Make sure there is room to spare between the casing and the hollow bore. If you make and use a jig like the one below, drive shaft removal will be easier.

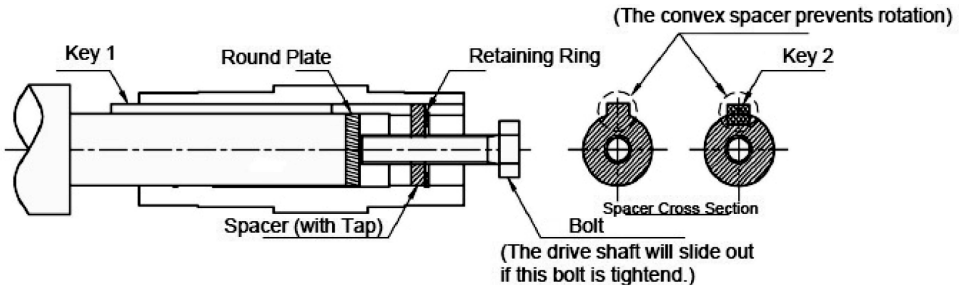

Fig. 5

(Customers needs to provide their own spacers, round plates, bolts and retaining ring keys.)

● How to Install the Reducer

The Advantages and Disadvantages of Flange and Torque Ann Installation

	Advantages	Disadvantages
Flange Installation	<ul style="list-style-type: none"> ● Can be installed directly on the device. ● Saves space. 	<ul style="list-style-type: none"> ● Centering with the application is required.
Torque Arm Installation	<ul style="list-style-type: none"> ● Makes centering with the application easy. ● Fastening to the application only requires one detent. 	<ul style="list-style-type: none"> ● Requires a torque arm. ● Requires space for installing a torque arm.

● Hollow Bore and Flange Installation

When tile hollow bore is installed directly to the flange of an application, it can cause motor burn-out or bearing damage if it is off-center, so be sure to center it properly. There is an installation guide, as shown in the diagram at the right. The dimension tolerance for ϕA for the installation guide is h7 in the case of F3S. The installation bolts are installed as shown in the diagram at tile right. Four bolts should be used.

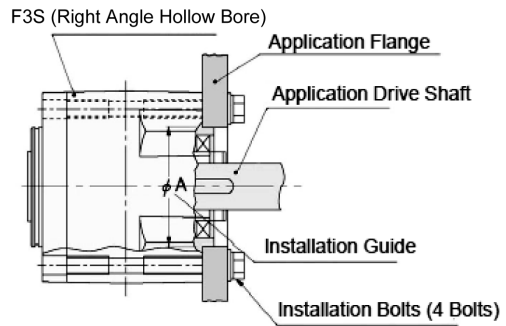

- Detailed diagram of tapped holes for F3 flange mount installation (standard specification)

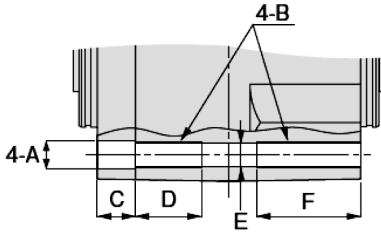

Fig. 6. 1

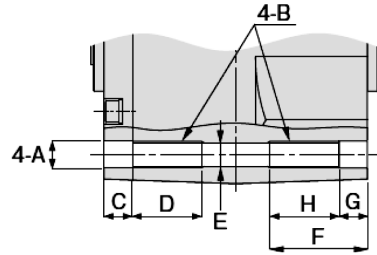

Fig. 6. 2

Frame No.	Reduction Ratio	Motor Power	Figure	A	B	C	D	E	F	G	H	
20	1/5 to 1/60	0.1kW (1/8Hp)	Fig. 6.1	10.5	M10 xP1.5	12	25	8.6	37	n/a	n/a	
25	1/5 to 1/60	0.2kW (1/4Hp)				14.5			39.5			
	1/80 to 1/240	0.1kW (1/8Hp)				14.5			39.4			
30	1/5 to 1/60	0.4kW (1/2Hp)				15.5			40.5			
	1/80 to 1/240	0.2kW (1/4Hp)		12.5	M12 xP1.75	15.5	30	10.6	45.5			
1/300 to 1/375	0.1kW (1/8Hp)	15.8				45.5						
35	1/5 to 1/60	0.75kW (1Hp)		16.5	M16 xP2	18	40	14	48			
	1/80 to 1/240	0.4kW (1/2Hp)				18			58			
	1/300 to 1/375	0.2kW (1/4Hp)				18			58			
	1/450 to 1/750	0.1kW (1/8Hp)				18			58			
45	1/5 to 1/60	1.5kW (2Hp)	20.5	M20 xP2.5	23	50	17.5	63				
	1/5 to 1/30	2.2kW (3Hp)			23			63				
	1/80 to 1/240	0.75kW (1Hp)			20.5			M20 xP2.5	23	50	17.5	73
	1/300 to 1/375	0.4kW (1/2Hp)										
	1/450 to 1/750	0.2kW (1/4Hp)										
	1/900 to 1/1200	0.1kW (1/8Hp)										
50	1/40 to 1/60	2.2kW (3Hp)	16.6	M16 xP2	19	40	14	59	19	40		
55	1/80 to 1/240	1.5kW (2Hp)	20.5	M20 xP2.5	21.5	50	17.5	71.5	21.5	50		
	1/80 to 1/120	2.2kW (3Hp)										
	1/300	0.75kW (1Hp)										
	1/450 to 1/600	0.4kW (1/2Hp)										
	1/900 to 1/1200	0.2kW (1/4Hp)										
	1/1500	0.1kW (1/8Hp)										

When attaching the mounting bolts, it is recommended to have the engagement of the bolt with thread D or F be at least two times the screw size (bolt diameter).(i.e. For an M10, 20 mm or more of thread engagement with D or F is recommended.)

● Fastening the Reducer and Torque Arm

- [1] Because the torque arm sustains a reactive force from rotation, consideration needs to be given to impact loads particularly during startup and braking, and bolts and plates that are sufficiently strong must be used. It's best to use an optional torque arm.
- [2] To install the torque arm and reducer, fasten them using spring washers and flat washers with the installation bolts.

Bolt Size and Tightening Torque (reference value)

Bolt Size	Tightening Torque N·m {kgf·m}
M8	13 {1.3}
M10	25 {2.6}
M12	44 {4.5}
M14	69 {7.0}
M16	108 {11}

● How to Install the Torque Arm Detent

[1] Oscillating Movement

Fasten the torque arm detent so there is no looseness or wobble. When doing this, center the detent hole with that of the application to make sure that no radial load (suspension load) is applied against the drive shaft and hollow bore of the reducer. (See Fig.7)

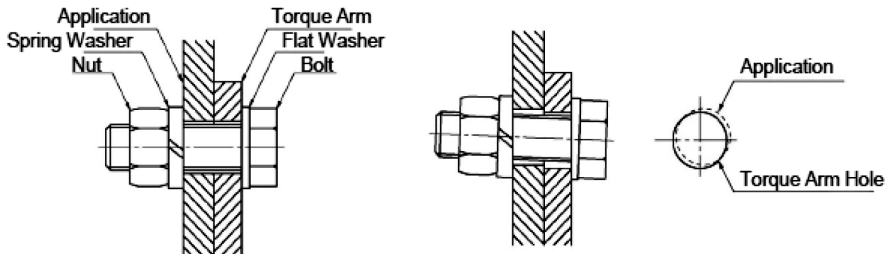

Fig. 7: Fastening the Detent

Unnecessary force applied to the drive shaft and hollow bore can result in defects.
Bad Example

Note: If looseness develops due to oscillating movement or start and stop frequency, start-up impact will be borne by the torque arm, causing the installation bolt to loosen, which can result in defects.

[2] Unidirectional Movement

When start-up torque is not frequently applied, the torque arm can be used without a detent. However, it is still necessary to fasten the drive shaft to the reducer. Refer to Fig.2-4, p.8-9. In this case, it is necessary to provide sufficient clearance for looseness in both radial and thrust directions for alignment between the application and detent. (See Fig. 8.)

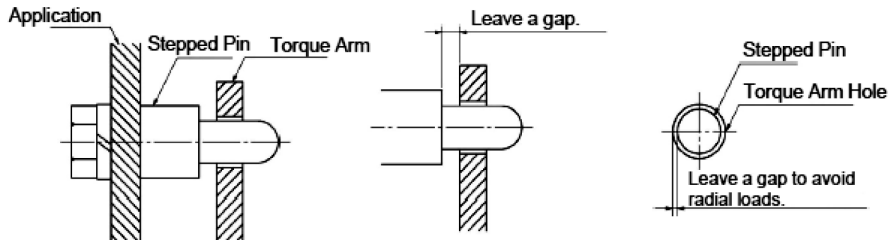

Fig.8: Example of Stepped Pin Usage

5 Direction of Rotation

The direction of the output shaft rotation of the IPM gearmotor is as follows when a CW direction is signaled by the driver.

• G3 Series (Viewed from the output shaft side)

- 0.1kW (1/8HP)
: 1/5 ~ 1/50 and 1/300 ~ 1/1200
- 0.2 ~ 2.2kW (1/4 ~ 3HP)
: 1/5 ~ 1/30 and 1/300 ~ 1/1200

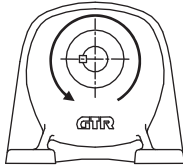

- 0.1kW (1/8HP)
: 1/60 ~ 1/200
- 0.2 ~ 2.2kW (1/4 ~ 3HP)
: 1/40 ~ 1/200

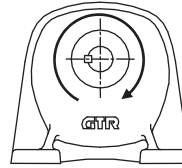

• H2 Series

- 0.1kW (1/8HP), 0.2kW (1/4HP) : 1/5 ~ 1/60 and 1/600 ~ 1/1500
- 0.4kW (1/2HP), 0.75kW (1HP) : 1/5 ~ 1/60 and 1/300 ~ 1/1500
- 1.5kW (2HP), 2.2kW (3HP) : 1/5 ~ 1/30

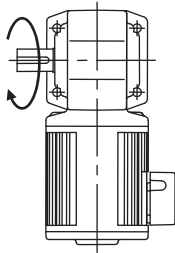

L-shaft

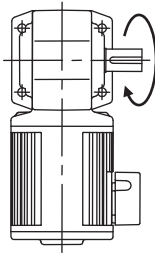

R-shaft

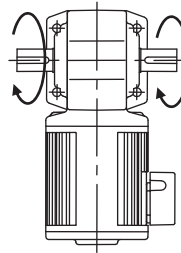

T-shaft

- 0.1kW (1/8HP), 0.2kW (1/4HP) : 1/80 ~ 1/450
- 0.4kW (1/2HP), 0.75kW (1HP) : 1/80 ~ 1/240
- 1.5kW (2HP), 2.2kW (3HP) : 1/40 ~ 1/240

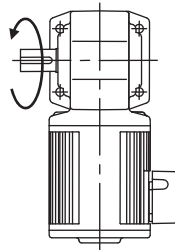

L-shaft

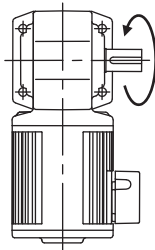

R-shaft

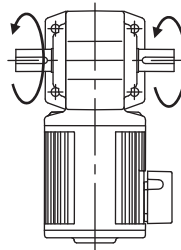

T-shaft

● F3 Series

• 0.1 ~ 2.2kW (1/8 ~ 3HP) : 1/5 ~ 1/60 and 1/300 ~ 1/1500

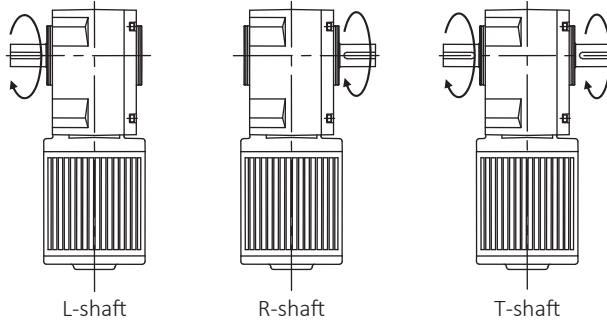

• 0.1 ~ 2.2kW (1/8 ~ 3HP) : 1/5 ~ 1/60 and 1/300 ~ 1/1500

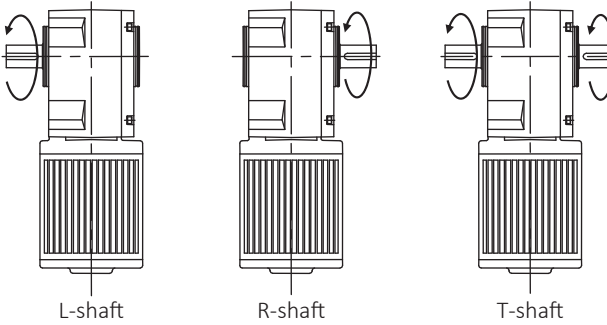

6 Wiring

Danger

- Be sure to confirm that the motor and driver have the correct input voltage and correct wiring. Failure to observe this warning may cause damage to the equipment, electric shock and/or fire.
- Do not to connect a commercial power supply to the motor directly. Failure to observe this warning may cause fire.
- When connecting power to the machine, follow the instructions shown on the connection diagram in the terminal box or in this Instruction Manual. Failure to observe this warning may cause electric shock or fire.
- Do not bend, pull or tuck motor cables or lead wires forcibly. Failure to observe this warning may cause electric shock.
- Be sure to ground the earth terminal, lead wire, or lug. Failure to observe this warning may cause electric shock.
- Be sure to use the power source specified on the name plate. Failure to observe this warning may cause the motor to burnout and/or fire.
- Avoid exposing the power rectifier or capacitor to water. Failure to observe this warning may cause electric shock, damage to the equipment, or fire.

Caution

- Do not touch the terminals or un-insulated wire connections when inspecting the insulation resistance. Failure to observe this warning may cause electric shock.
- Wires should be connected properly using the specified electrical standard or safety code. Failure to observe this warning may cause electric shock, fire or physical injury.
- When operating a gearmotor not connected to a load, remove the key from the output shaft. Failure to observe this warning may cause physical injury.
- Check the direction of rotation before connecting the gearmotor to the machine's load. Rotation in the wrong direction may cause physical injury and/or damage to the equipment.
- Voltage drop in the wiring should be kept above 2%. Excessive length of wiring may cause a severe voltage drop. Voltage drop reduces starting capacity and may result in the load not starting.
- When using a gearmotor with a brake do not energize the brake coil continuously while the motor is not running. The brake coil of totally enclosed, fan cooled motors may rely on the motor fan for cooling. Continuous operation without the effect of the fan may cause the brake coil to burn out and/or fire.
- Totally enclosed, non-ventilated, brake-equipped motors do not rely on the fan for cooling. However, continuously energizing the coil without motor operation may still cause damage.
- If a gearmotor with a brake is used as a lift or hoist; DC Switching wiring should be used. Failure to use DC Switching may result in the lift or hoist falling and causing damage to the equipment or physical injury.

Special Notes About Wiring

- (1) As the rectifier unit contains diodes, improper wiring may cause fatal short-circuiting and breakage of the unit. So, special care should be taken for wiring.
- (2) In case DC Switch is adopted, DC110V <DC220V>, contact rated DC13 class is recommended in order to cut off the inductive load (DC coil). Please contact us for details.
* The capacity in the parenthesis < > is the one at 400V with brake (yellow lead wire).
- (3) The direction of rotation of the output shaft varies according to the speed reduction ratio of the gear head. Therefore, be sure to confirm the speed reduction ratio before wiring.

① Wiring of gearmotor

Connect the gearmotor as shown below. Do not interchange pre-installed wiring on the terminal block.

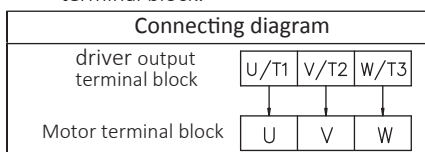

② Detail of terminal box

- The size of the terminal clinchers is M4.

- J-type terminal box (plastic compact)

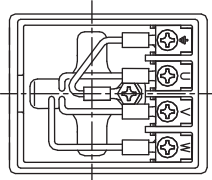
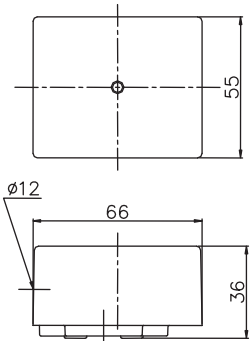
Standard Type	 <p style="text-align: center;">← Fan cover side</p> <p>(Note) The brake lead wire appears directly from the brake. (for brakemotor type)</p>	 <p>(Note) If the box cover is attached upside down, the position of the opening for the power cable changes to the bottom side.</p>
---------------	--	--

- T-type terminal box (Steel)

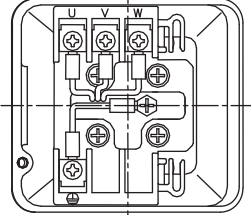
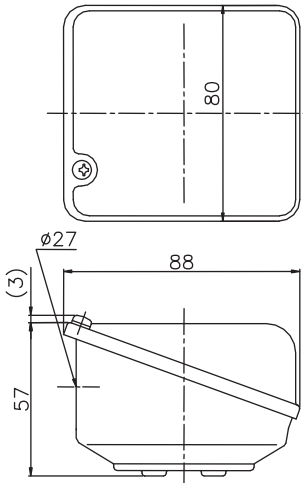
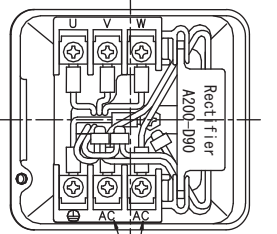
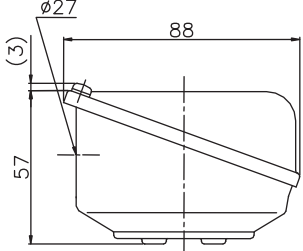
Standard Type	 <p style="text-align: center;">← Fan cover side</p> <p>(Note) The brake lead wire appears directly from the brake. (for brakemotor type)</p>	
AC Switching (built in rectifier)	 <p style="text-align: center;">← Fan cover side</p> <p style="text-align: center;">Input of a rectifier</p>	

■ L-type terminal box (plastic)

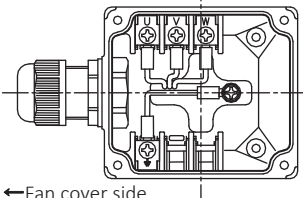
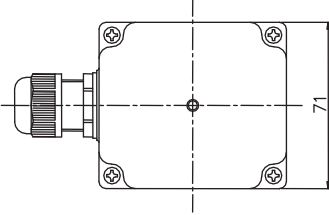
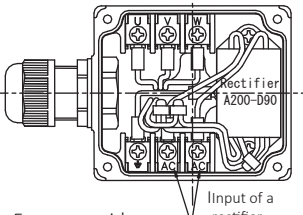
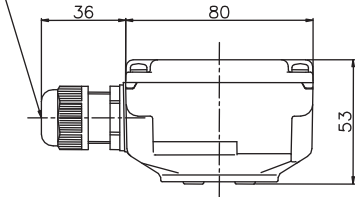
Standard Type	 <p>← Fan cover side</p> <p>(Note) The brake lead wire appears directly from the brake. (for brakemotor type)</p>	 <p>71</p> <ul style="list-style-type: none"> • 0.1~0.4kW (1/8~1/2HP) : Applicable cable diameter $\phi 7 \sim \phi 12.5$ • 0.75kW (1HP) : Applicable cable diameter $\phi 8.5 \sim \phi 14$
AC Switching (built in rectifier)	 <p>← Fan cover side</p> <p>Rectifier A200-D90</p> <p>Input of a rectifier</p>	 <p>36 80 53</p>

■ E-type terminal box (aluminum) for IP65 type

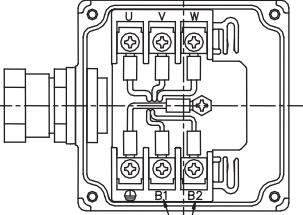
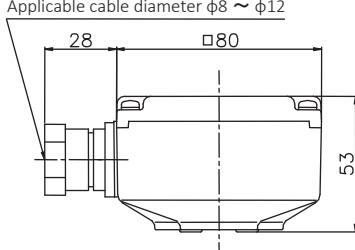
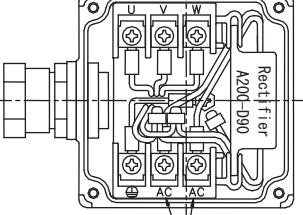
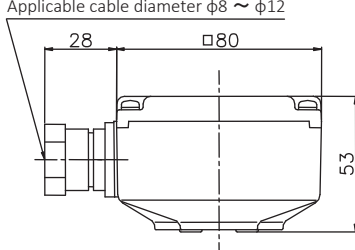
Standard Type	 <p>← Fan cover side</p> <p>Brake lead wire (for Brakemotor type)</p>	 <p>Applicable cable diameter $\phi 8 \sim \phi 12$</p> <p>28 80 53</p>
AC Switching (built in rectifier)	 <p>← Fan cover side</p> <p>Rectifier A200-D90</p> <p>input of a rectifier</p>	 <p>Applicable cable diameter $\phi 8 \sim \phi 12$</p> <p>28 80 53</p>

③ Wiring of Brake

- (1) Be sure to bypass the driver when wiring the brake. Otherwise, malfunction of the brake may be observed due to the voltage drop.
- (2) If a gearmotor is used in the applications where quick braking is required, such as lift, "DC Switching" wiring should be employed.
- (3) In case of "DC Switching" wiring, it is recommended to insert the surge suppressor in between the connecting points. (Snubber voltages should be between 423 ~ 517V for 90VDC brakes.)
- (4) The brake voltages are DC90V for 200V brake (blue lead wire).
- (5) The brake circuit relay is recommended to use an electro-magnetic switch with the capacity of more than the rated current of 6A (AC200V). In case DC Switching wiring is employed, an electro-magnetic switch with a capacity of DC110V, contact rated DC13 class is recommended to shield the inductive load (DC coil). If using a noncontact relay, the electro-magnetic switch with a capacity equivalent to the rated voltage of AC240V is recommended. (Half-wave rectification load can be switched.)
 *Auxiliary contact rated DC13 is a type of JIS C 8201-5-1
 (low pressure switching and controlling device) when applied to a coil load.
- (6) Special care should be taken when wiring as the rectifier unit contains diodes. Improper wiring may cause short-circuiting and damage to the unit.
- (7) Please refer to the driver's instruction manual about the timing of operation commands and brake ON/OFF.

■ DC Switching

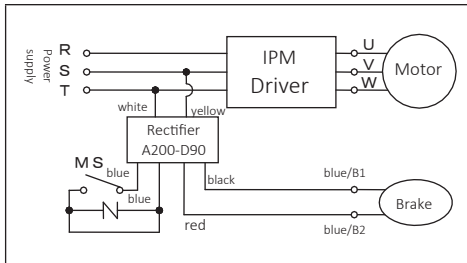

■ AC Switching

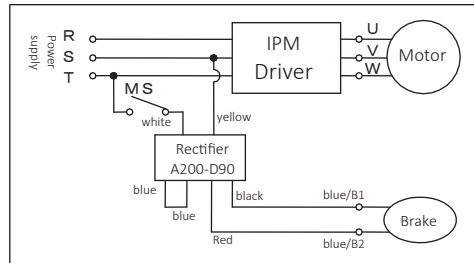

■ AC Switching (built in rectifier)

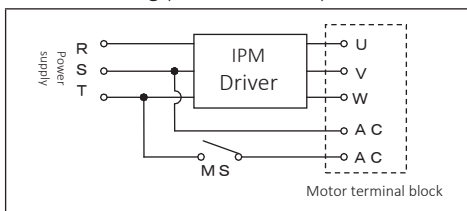

MS : Magnetic Switch
 →N : Protection Device (Option)

7 Operation

Danger

- Do not operate the gearmotor with the terminal box cover opened. Failure to observe this warning may cause electric shock.
- Do not approach or touch rotating parts such as a shaft while the machine is running. Failure to observe this warning may cause physical injury.
- If power loss occurs; switch off the power supply to the machine. Unexpected recovery of electric service may cause a sudden start of the gearmotor and cause physical injury and/or damage to the equipment.

Caution

- The gearmotor may become hot during operation. Do not touch it with your bare hands. Failure to observe this warning may cause burn injury.
- If a gearmotor is running abnormal, stop it immediately. Failure to observe this warning may cause electric shock, physical injury or fire.
- Do not overload a gearmotor. Failure to observe this warning may cause physical injury and/or damage to the equipment.
- Do not stop or stall a motor forcibly. It may cause damage to the machine.

① Check these items before turning the power switch on:

- (1) Wiring and connections are done properly to required codes.
- (2) Fuses and thermal relays of proper capacity are used.
- (3) Installation and the connection with the machine is properly done.
- (4) The earth terminal, lead wire, or lug is properly grounded.

② Check these items during the initial test run:

- (1) Confirm the direction of rotation for 1 ~ 2 seconds by starting the motor in the unloaded condition. If you find improper rotational direction, change the wiring.
- (2) Test run the gearmotor with the machine in an unloaded condition. When no defect is observed, add load gradually and eventually start operation under the full load.

③ Check these items during operation:

- (1) Confirm there is no abnormal noise and/or vibration. Stop operation of the gearmotor immediately if abnormal noise or vibration occurs. Failure to observe this warning may cause physical injury and/or damage to the equipment.
- (2) Confirm the surface temperature of the gear case and motor frame does not exceed 176F (80°C). Do not touch the surface of the gearmotor with your bare hands. Failure to observe this warning may cause a burn injury.

8 Specifications

① Motor Specifications

Motor Type		IPM Motor (Interior Permanent Magnet Motor)					
Motor Power Designation		010	020	040	075	150	220
Motor Power		0.1kW (1/8HP)	0.2kW (1/4HP)	0.4kW (1/2HP)	0.75kW (1HP)	1.5kW (2HP)	2.2kW (3HP)
Motor Poles (Note.1)		4 pole			6 pole		
Maximum Torque		150%					
Rated Current (A) (Note.2)		0.45	0.86	1.74	3.37	6.13	8.20
Minimum Rotation Speed (rpm) (Note.3)		0					
Rated Rotation Speed (rpm)		1800 (60Hz)			1800 (90Hz)		
Maximum Rotation Speed (rpm) (Note.4)		2500 (83.4Hz)			2500 (125Hz)		
Speed Control Range at Rated Torque (rpm)		180 ~ 1800 (1:10)			120 ~ 1800 (1:15)		
Degrees of Protection	Motor Type	M	Totally Enclosed Non-Ventilated (IP40 or IP44) (Note.5)		Totally Enclosed Non-Ventilated (IP44)	Totally Enclosed Fan-Cooled (IP44)	
		B-J	Totally Enclosed and Self-circulation (IP40 or IP44) (Note.5)				
		G	Totally Enclosed Non-Ventilated (IP65)			Totally Enclosed Fan-Cooled (IP65)	
		H					
Insulation Class		Class B (for EN standard), Class A (for UL standard)					

Note 1. The number of motor poles is dependent on the motor power. The relation between the rotation speed of motor and the frequency is calculated according to the following equation.

$$\text{Rotating Speed (rpm)} = \frac{120 \times \text{Set value of frequency}}{\text{Motor pole number}}$$

- The Rated Current in the table above is a reference value without the gearhead. (motor unit only)
- Rotational fluctuation of a motor tends to increase when operating at less than 100 rpm.
- The range between 1800rpm and 2500rpm is a limited torque range. Be sure to refer to the allowable torque.
- The IP code (IP40 or IP44) depends on the type of the terminal box. Motor type IP40 and IP44 are not waterproof. Do not splash water and/or oil on the gearmotor for these types.

② Brake Specifications

- (1) The holding brake should only be used to hold a load. It should not be used to stop the gearmotor.
- (2) Do not energize the brake continuously while the motor is stopped.
- (3) Please refer to the driver's instruction manual about the timing of the operation commands and brake ON/OFF.
- (4) Do not use the brake while the motor enters servo lock status. Otherwise, the motor may become overloaded.

Motor Power Item	0.1kW (1/8HP)		0.2kW (1/4HP)		0.4kW (1/2HP)		0.75kW (1HP)		1.5kW (2HP)	2.2kW (3HP)
Motor Power Designation	010		020		040		075		150	220
Motor Type	B·J	H	B·J	H	B·J	H	B·J	H	B·J	B·J
Brake Type	Power-off (Spring close)									
Holding Torque (N·m) { kgf·m} (Note.1)	0.98 {0.10}		1.96 {0.20}		3.92 {0.40}		7.35 {0.75}		14.7 {1.50}	21.6 {2.20}
DC voltage (average) with rectifier (V)	90									
Power (at75°C) (W)	14	10	14	10	16	12	24	16	37	37
Current (at75°C) (A)	0.15	0.11	0.15	0.11	0.18	0.13	0.27	0.17	0.41	0.41

(Note.1) Holding torque is a reference value. It does not ensure safety.

③ Operation Range

- (1) Allowable torques described in the product catalog are continuous values at 1800 rpm. For more than 1800 rpm, use the derate according to the following diagrams.
- (2) The allowable O.H.L. can also be obtained by the derate shown below.
- (3) As for the allowable inertia moment I { allowable GD^2 }, if using the motor at over 1800 rpm, it can be obtained by multiplying $(1800/\text{input rpm})^2$ to the allowable inertia moment in the product catalog.

When using a Brother driver (VF-nC3M).

●0.1kW (1/8HP), 0.2kW (1/4HP), 0.4kW (1/2HP)

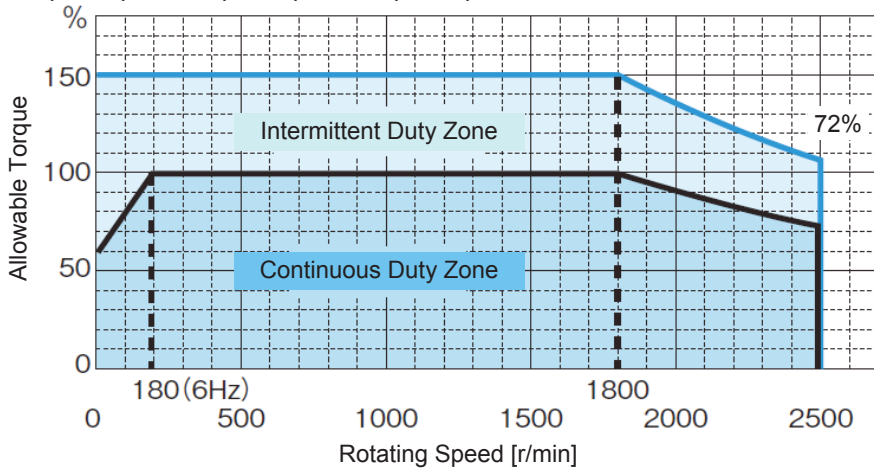

●0.75kW (1HP), 1.5kW (2HP), 2.2kW (3HP)

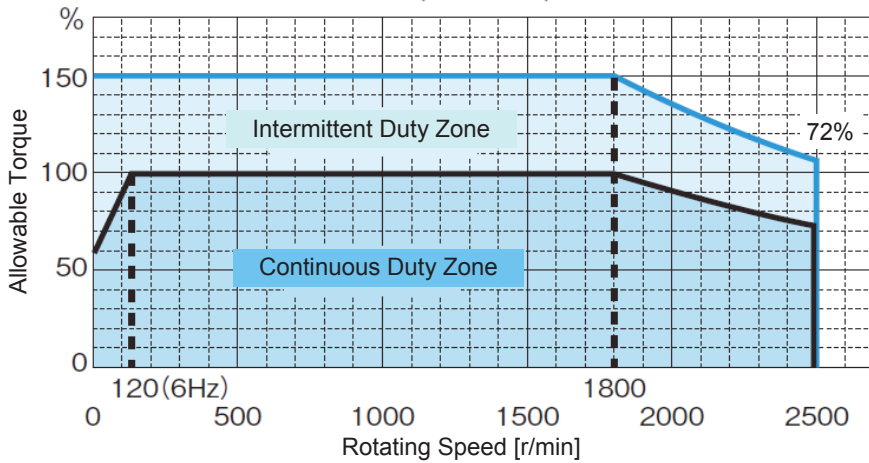

9 Inspection and Adjustment

Danger

- When inspecting and/or adjusting the machine while it is in operation, do not touch rotating parts such as a shaft. Failure to observe this warning may cause physical injury.
- Do not attempt to disassemble the gearmotor while it is in operation. Lubricant may blow-out and cause a burn injury. Opening the motor may cause electric shock.
- If the gearmotor is enclosed inside the equipment and you need to inspect it, be sure to immobilize the gearmotor drive shaft and the machine drive shaft prior to inspection. Also, confirm the equipment is sufficiently cooled down before attempting any inspection.
- During any inspection, please have support personnel outside the machine to watch safety conditions. If lubricant has spilled it can be very slippery, please use caution. Failure to observe this warning may cause physical injury.
- Do not operate the equipment with safety guards off. Failure to observe this warning may cause physical injury.

[Inspection and Maintenance of Brake Parts]

- Do not operate the equipment with the manual release lever of a brake disengaged. Failure to observe this warning may cause damage to the equipment, physical injury, or death.
- Before starting the equipment, make sure the brake is functioning properly. Turn the switch on and off and listen for the "click" of the brake. Failure to observe this warning may cause malfunction of the machine, loss of brake function resulting in damage to the equipment, physical injury, or death.
- Do not operate the equipment without the fan cover (or brake cover) installed after inspection and adjustment of brake gap. Failure to observe this warning may cause wind-in and physical injury.
- Do not release the brake while the equipment is operating. Failure to observe this warning may cause the machine to run out of control, damage the equipment and result in physical injury or death.

Caution

- When measuring the insulation resistance do not touch the terminals. Failure to observe this warning may cause electric shock.
- The surface of the gearmotor may be very hot. Do not touch it with your bare hands. Failure to observe this warning may cause burn injury.
- When abnormal operation is observed; diagnose the fault according to the instruction manual. Do not operate the machine until the cause of the fault is found and proper measures are taken to correct the matter.
- Repairing, disassembling and reassembling of the equipment should be done only by an experienced technician. Failure to observe this warning may cause electric shock, physical injury or fire.
- Improper disassembly of the gearmotor voids the warranty.

[Note] In case you need to change grease, oil seal or O-ring for maintenance or inspection, be sure to ask our local sales office. Please note that we will not be responsible for damage caused by a user's changing of lubricant or parts.

① Daily Inspection: The following items should be inspected every few days.

Inspection item	Interval	Details of Inspection
Load current	Ammeter	Compare it to the full load current on nameplate.
Noise	Human Ear Detection Rod	No abnormal rumbling, grinding, clicking, ticking or other periodic sound. An acoustic detection rod makes it easier to pick up the abnormal noise.
Vibration	Touch (Please wear protective gloves)	No abnormal vibration in the gear case and motor frame.
Surface Temperature	Thermometer	Less than 176F (80°C)
Grease Leakage	Visual	No lubricant leaking from the casing joints, oil seals, brackets, etc.

② Periodic Inspections: (In case of operating 8 hours a day)

Inspection item	Interval	Details of Inspection
Fixing Bolt	6 months	Check to see if the bolt is loose. Retighten if necessary.
Chain or V-belt	6 months	Check tension (loose or tight) and adjust to proper tension.
Insulation Resistance of Motor	6 months	More than 1MΩ when insulation resistors is 500V.
Brake Gap	1 Year or 1 ~ 1.5Million Cycles	Check if the gap is within the allowable limit. Refer to next Page. Adjust as instructed.
Brake Friction Disk	1 Year	Check the thickness of the friction disk. Replace if the disk is less than 1.5 mm. Consult Brother or your Brother Distributor for a replacement friction disk.

When any abnormality is found during the daily inspection, take proper measures according to the troubleshooting found in Section 10 of this Instruction Manual.

③ Brake Gap "g" Adjustment for Brake Equipped Gearmotor.



- 1 When adjusting the gap disconnect the motor from the power source. Failure to observe this warning may cause physical injury.
- 2 After inspection and adjustment of the gap, be sure to confirm the brake functions properly. Failure to observe this warning may cause an accident or allow the machine to run out of control.
- 3 After inspection and adjustment of the gap, do not operate the motor with the fan cover (or brake cover) open. Failure to observe this warning may cause physical injury.

Note: Brake Gap "g" Adjustment

After operation for an extended period of time, the friction disk of the brake wears and the gap (g) increases. When the gap clearance becomes too large the armature cannot function and the brake will become ineffective or fail. Continuous usage of a brake when the gap is out of specification causes excessive temperature rise in the brake coil and will lead to coil failure. For safe operation, the brake gap should be inspected every 12 months or 1 ~ 1.5 Million cycles.

Standard Motor:

Procedure for Brake Gap "g" Adjustment

- ① Remove fan cover.
- ② Lift the tooth of the castellated nut from the securing slot. Also, loosen the set screw for single phase motors.
- ③ Press down the friction disk and tighten the castellated nut by hand until it is firmly locked.
- ④ Then, turn back the nut to the loosening direction at about $100^\circ \sim 180^\circ$. In the event of the castellated nut is removed, be sure to attach it in the right direction. (Refer to the figure on the right, which shows the attaching direction of the castellated nut.) And confirm if the gap clearance is proper, by using gap gauge.
- ⑤ Press the tooth of the castellated nut into the nearest slot on the friction disk.
- ⑥ Install the fan cover.

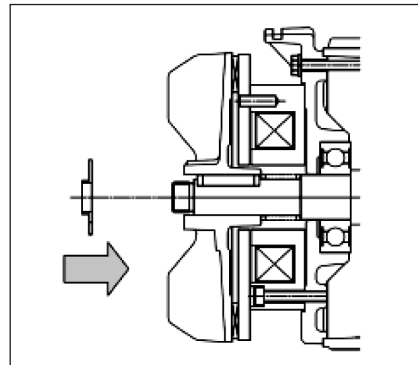

Attaching direction of the castellated nut.

[Note] Do not allow grease or dust to adhere to the friction disc. Failure to observe this warning will cause a decrease in braking performance.

Motor: 0.1kW(1/8HP), 0.2kW(1/4HP), 0.4kW(1/2HP), 0.75kW(1HP)

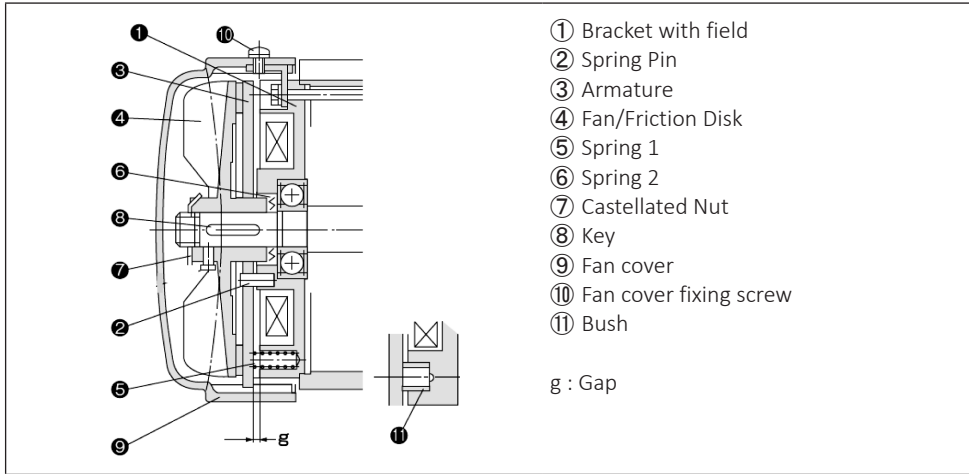

Motor: 1.5kW(2HP), 2.2kW(3HP)

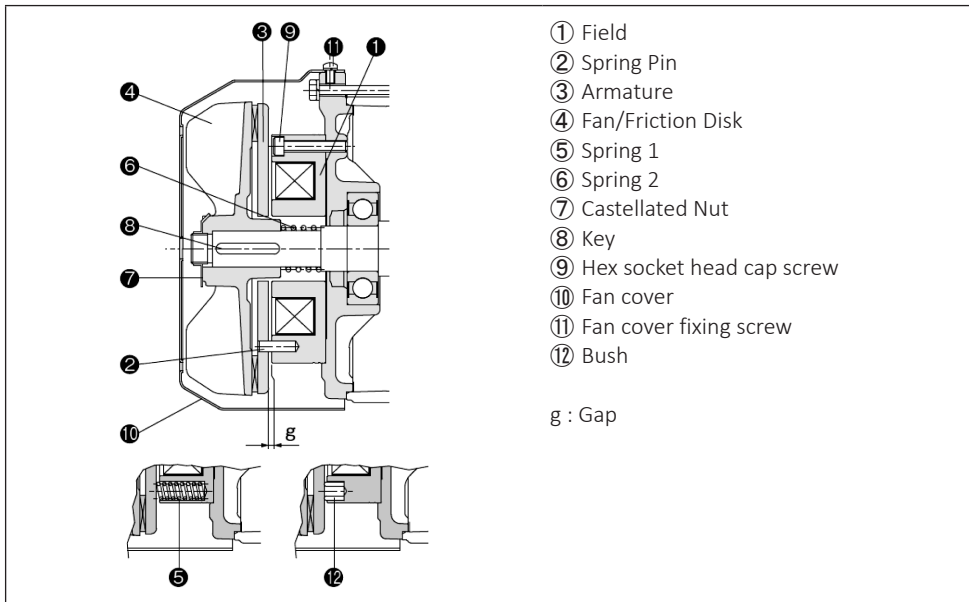

Gap “g” Data: Standard Motors

Motor Power	Allowable Gap “g” (mm)	Proper Gap “g” (mm)
0.1kW (1/8HP), 0.2kW (1/4HP)	Less than 2.3	1.9 +/- 0.1
0.4kW (1/2HP)	Less than 1.8	1.4 +/- 0.1
0.75kW (1HP)	Less than 2.4	2.0 +/- 0.1
1.5kW (2HP), 2.2kW (3HP)	Less than 1.0	0.4 +/- 0.1

Water resistant IP-65 Motor :
Procedure for Brake Gap “g” Adjustment

- ① Remove the brake cover.
- ② Lift the tooth of the castellated nut from the securing slot.
- ③ Press down on the friction disk and tighten the castellated nut by hand until it is firmly locked.
- ④ Then, turn back the nut to the loosening direction at about 100° ~ 180°. In the event of the castellated nut is removed, be sure to attach it in the right direction. (Refer to the figure on the right, which shows the attaching direction of the castellated nut.) And confirm if the gap clearance is proper, by using gap gauge.
- ⑤ Press the tooth of the castellated nut into the nearest slot on the friction disk.
- ⑥ Install the brake cover. Check if there is any damage in the o ring of the brake cover before installation. If damage exists, replace it with new one.
- ⑦ Replace the brake cover.

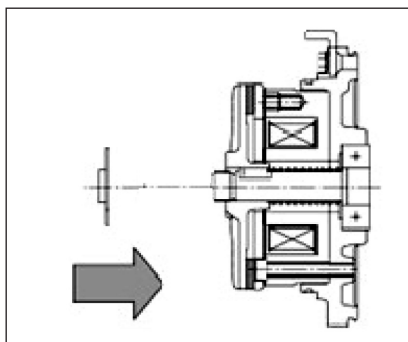

Attaching direction of the castellated nut.

[Note] Do not allow grease or dust to adhere to the friction disc. Failure to observe this warning will cause a decrease in braking performance.

Motor: 0.1kW(1/8HP), 0.2kW(1/4HP), 0.4kW(1/2HP), 0.75kW(1HP)

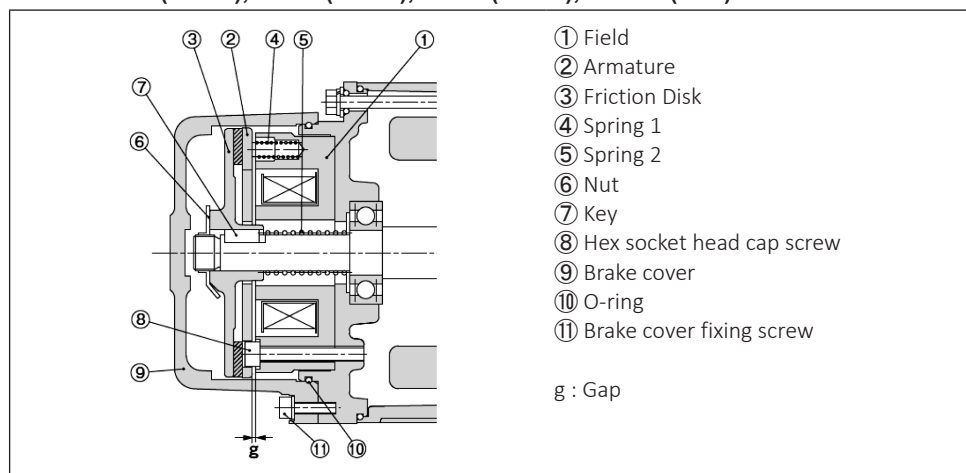

Gap “g” Data: Standard Motors

Motor Power	Allowable Gap “g” (mm)	Proper Gap “g” (mm)
0.1kW(1/8HP)	Less than 0.8	0.3 +/- 0.1
0.2kW(1/4HP), 0.4kW(1/2HP)	Less than 0.7	0.3 +/- 0.1
0.75kW(1HP)	Less than 0.9	0.3 +/- 0.1

④ Warning Label

A warning label is attached to the gearmotor. If the label peels off or becomes hard to read, contact Brother for a replacement label.

⑤ Grease, Oil seal and O-Ring

- (1) All gearboxes are filled with grease before shipping from our factory. Therefore, machines are available for immediate use.
- (2) Replacement or refilling of the lubricant is not necessary. However, replacing it once every 10,000 hours may help prolong the life of the reducer. If lubricant replacement is required, be sure to use factory authorized grease and consider using an authorized factory.
- (3) Our machines are protected from grease leakage by an oil seal and/or O-ring. While our sealing is reliable, it is recommended to protect the machine with an oil pan for safety. (Grease leakage may be observed when the machine is in trouble or at the end of life.)
- (4) The life of the oil seal will vary according to the conditions of use. Therefore, replacement may be needed even within 10,000 hours use. For replacement of oil seal, be sure to use authorized factory.

10 Troubleshooting

Trouble	Cause	Troubleshooting
The motor does not run even in the unloaded condition.	Disconnection of a wire	Check the wiring
	Poor contact of a switch	Repair or replace the relay.
	Disconnection of stator coil.	Repair at authorized factory.
	Broken gear, shaft or bearing	Repair at authorized factory.
The motor does not run in the loaded condition.	Voltage drop	Check the length and diameter of the power cable.
	Worn out gear	Repair at authorized factory.
	Overload operation	Reduce the load.
Abnormal rise in temperature	Overload operation	Reduce the load.
	High frequency of start and stop	Reduce the load.
	Damage to bearings	Repair at authorized factory.
	Overvoltage or low voltage	Check the voltage.
Abnormal noise	Continued noise- defective bearing, worn out gear	Repair at authorized factory.
	Intermittent noise—damaged gear or foreign substances inside the motor	Repair at authorized factory.
Excessive vibration	Worn out gear or bearing	Repair at authorized factory.
	Improper installation or loose bolts	Tighten the bolts.
Brake does not work	Improper wiring	Check the wiring
	Damaged switch	Replace or repair the switch
Brake function is not enough.	Foreign substances or oil are adhered to the friction disk.	Remove foreign substances and/or oil. Repair at authorized factory.
	Worn out friction disk (Thickness less than 1.5mm (1/17 in))	Replace the friction disk.
Motor does not run. (Rotating speed does not increase.) Overheated motor. Overload alarm trips. Abnormal noise in braking.	Wrong brake wiring.	Check the wiring.
	Large brake gap.	Adjust the brake gap.
	Failure of the rectifier.	Replace the rectifier.
	Poor contact of switch.	Replace or repair the switch

11 Storage

●Storage Location

- (1) Avoid storage outdoors or in places with humidity, dust, sudden temperature changes or corrosive gas.
- (2) Do not store directly on the ground.
- (3) Avoid a place with vibration. Otherwise, fretting corrosion may damage the bearing.

●During Storage Period

- (1) Rotate the gearmotor every 6 months for rust prevention of the bearing.
- (2) Check the insulation resistance of the motor to make sure it is more than $1M\Omega$ by using a 500V insulation resistance tester every 6 months.
- (3) Rustproof the output shaft every 6 months.

●Use After Storage

- (1) Before using the gearmotor, check the insulation resistance of the motor to make sure it is more than $1M\Omega$ by using a 500V insulation resistance tester.
- (2) After starting the gearmotor, verify that there is no abnormal noise, vibration or heat.
- (3) If supplied as a Brakemotor, check that the brake operates properly. If any abnormality is observed, contact our nearest sales office.

12 Standard Terms and Conditions of Sale

General

These standard Terms and Conditions of Sale shall be incorporated into any contract between Purchaser and Brother International Corporation (hereafter Brother) and shall apply to all purchase orders issued by Purchaser. Unless specifically provided herein or in a separate written agreement duly executed by Brother, the quotation and this form constitute the entire agreement between Brother and Purchaser and no other terms or conditions oral or written shall be of any effect. All orders, whether placed pursuant to a quotation or not, are accepted only upon express condition that purchaser agrees to the Terms and Conditions as specified herein.

Price and Delivery Terms

Price and delivery terms are F.O.B. Brothers nearest U.S. facility and do not include sales, use, excise, or any other taxes. Our responsibility ceases when delivery is made to the transportation company and any claims for loss or damage in transit must be handled by the Purchaser with the carrier.

Packing

No charge is made for standard boxing for domestic shipments. Purchaser will be quoted and charged separately for export or special packing requirements.

Payment Terms

To Purchasers with credit standing satisfactory to Brother, terms of payment are cash in full, net 30 days. If at any time Brother deems that by reason of financial condition of the Purchaser or otherwise, the continuance of production or shipments is not justified, Brother may revoke its extension of credit, enforce any security interest(s) created hereby on all goods furnished by Brother to the Purchaser and otherwise secure itself as to Purchasers performance of its obligation.

Cancellation

Changes, suspension or cancellation of any order by Purchaser may be made only upon written approval of an authorized officer of Brother.

Warranty

All Brother gearmotor product are warranted against defects in materials and workmanship for a period of 2 years from the date of manufacture. This constitutes Brother's only warranty in connection with this safe, and is in lieu of all other warranties expressed or implied, written or oral. There are no implied warranties of merchantability or fitness for a particular purpose that apply to this sale. If performance guarantees are requested, they should be requested in writing. Full consideration will be given to such requests when complete details of the proposed application are included.

Limitation of Remedy

Brother will repair or replace, at brother's option, F.O.B. Brother's factory, freight prepaid, any Brother gearmotor proved defective in materials or workmanship if immediate written notice of claim is made to Brother by Purchaser within 2 years from the date of manufacture. It is agreed that such repair or replacement is the exclusive remedy available from Brother. Under no circumstances shall Brother be liable to anyone for any special, incidental or consequential damages, whether the result of negligence or otherwise.

Warranty Exclusions

The Warranty of Brother gearmotor products does not cover and Brother makes no warranty with respect to:

1. Failures not reported in writing to Brother within the warranty period of 2 years after the date of manufacture.
2. Failures or damages due to miss-application, abuse, improper installation or abnormal conditions of temperature, humidity, dirt or corrosive matter.
3. Failures due to operation, either intentional or otherwise, above rated capacities or in an otherwise improper manner.
4. Product which has in any way been tampered with or altered by anyone other than an authorized representative of Brother.
5. Expenses incurred by the Purchaser in an attempt to repair or rework an allegedly defective product.
6. Product damaged in shipment or otherwise without the fault of Brother.

Returns

No product will be accepted for return unless authorized in writing with a returned merchandise authorization (RMA) number assigned. Any returned goods must be returned with transportation charges prepaid.

Regulatory Laws and/or Standards

It is the Purchaser's obligation to install and operate all Brother gearmotor products in conformance with all applicable national or local laws and safety codes.

Patents

Brother represents that its gearmotors are designed and manufactured such that they do not infringe on any United States Patent(s), and that Brother will, at its expense, defend any claim charging such infringement and will save Purchaser harmless from any adverse judgements resulting there from. Purchaser agrees to give Brother, prompt written notice of any claim of infringement and to turn over to Brother the complete control of any litigation involving such claims including the right to settle such claims. This indemnity does not apply to Products which are incorporated by the Purchaser into Products which are changed to infringe a Patent or to Product which is used by Purchaser in performance of a method or process which is charged to infringe a Patent.

Law

These Standard terms and Conditions of Sale shall be interpreted in accordance with the Laws of the State of New Jersey.

Severability

If any of the terms and Conditions shown here are determined to be invalid, illegal, or unenforceable the remainder of these Terms and Conditions shall remain in full force and effect.



brother
at your side

Brother International Corporation
Gearmotor Division

200 Crossing Blvd. Bridgewater, NJ 08807

Phone: 866-523-6283 | Fax: 908-704-8235

www.BrotherGearmotors.com

E-mail: GearMotors@brother.com

2018/11

Ver. 1.0

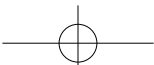

Free Manuals Download Website

<http://myh66.com>

<http://usermanuals.us>

<http://www.somanuals.com>

<http://www.4manuals.cc>

<http://www.manual-lib.com>

<http://www.404manual.com>

<http://www.luxmanual.com>

<http://aubethermostatmanual.com>

Golf course search by state

<http://golfingnear.com>

Email search by domain

<http://emailbydomain.com>

Auto manuals search

<http://auto.somanuals.com>

TV manuals search

<http://tv.somanuals.com>